



REGIONAL WOOD ENERGY DEVELOPMENT PROGRAMME IN ASIA
GCP/RAS/154/NET



BIOMASS BRIQUETTING: TECHNOLOGY AND PRACTICES

P.D. Grover & S.K. Mishra

**FOOD AND AGRICULTURE ORGANIZATION OF THE UNITED NATIONS
Bangkok, April 1996**

This publication is printed by
the FAO Regional Wood Energy Development Programme in Asia,
Bangkok, Thailand

The designations employed and the presentation of material in this publication do not imply the expression of any opinion whatsoever on the part of the Food and Agriculture Organization of the United Nations concerning the legal status of any country, territory, city or area or of its authorities, or concerning the delimitations of its frontiers or boundaries.

The opinions expressed in this publication are those of the author(s) alone and do not imply any opinion on the part of the FAO.

For copies write to: Regional Wood Energy Development
Programme in Asia
c/o FAO Regional Office for Asia and the Pacific
Maliwan Mansion, Phra Atit Road,
Bangkok, Thailand

Tel: 66-2-280 2760
Fax: 66-2-280 0760
E-mail: rwedp@fao.org
Internet: <http://www.rwedp.org>

FOREWORD

In April 1995 an International Workshop on Biomass Briquetting was organised by the Department of Chemical Engineering of the Indian Institute of Technology-Delhi. The Workshop was sponsored by the Technology and Development Group of the University of Twente, The Netherlands, and the Indian Renewable Energy Development Agency Ltd., India. The Workshop reported the main results of the Biomass Densification Research Project, which was jointly implemented by the two named universities and two private sector companies (Solar Sciences Consultancy Pvt. Ltd, and DENSI-TECH). Results from briquetting activities in other countries in Asia were also reported, and various technical and financial aspects of briquetting were addressed in the International Workshop. The Proceedings of the Workshop were published by RWEDP in 1996.

It is clear from the Workshop that substantial progress has been made in briquetting technology and practices in recent years. RWEDP considers briquetting of biomass residues for fuel an important option for substitution of wood and loose biomass residue fuels, under certain conditions. However, the option should be carefully evaluated and any implementation should be based on a thorough understanding of the requirements and constraints.

The Field Document on 'Biomass Briquetting: Technology and Practices' has been prepared by P.D. Grover and S.K. Mishra of IIT-Delhi, and published by RWEDP as a complement to the named Proceedings. The publication may help readers to further familiarise themselves with the technology and practices of biomass briquetting.

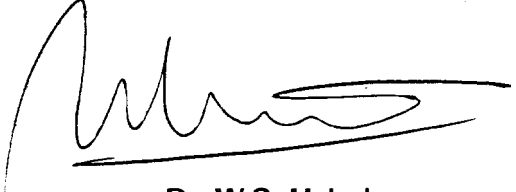

Dr. W.S. Hulscher
Chief Technical Adviser

TABLE OF CONTENTS

	Page
FOREWORD	i
1. INTRODUCTION	1
2. POTENTIAL AGRO-RESIDUES AND THEIR CHARACTERISTICS	4
2.1 Potential Agri-residues	4
2.2 Appropriate Biomass Residues for Briquetting	4
3. FUNDAMENTAL ASPECTS OF BRIQUETTING	7
3.1 Pressure Compaction	7
3.2 Binding Mechanisms of Densification	8
3.3 Mechanism of Compaction	8
4. BRIQUETTING TECHNOLOGIES	10
4.1 Screw Press and Piston Press Technologies	10
4.2 Other Briquetting Technologies	12
4.3 Compaction Characteristics of Biomass and Their Significance	12
4.4 Unit Operations	14
4.5 Briquetting Plant	15
4.6 Material Processing Equipment	15
4.7 Briquette Storage	19
5. LATEST DEVELOPMENTS INCLUDING FEED PREHEATING	22
5.1 Essentials of Preheating	22
5.2 Preheating Phenomenon	22
5.3 Preheater	23
6. MATERIAL AND ENERGY BALANCE	28
6.1 Prerequisite Step	28
6.2 Feed Processing	28
6.3 Preheater	28
6.4 Briquetting and Cooling	29
6.5 Furnace	29
6.6 Information Flow Structure	29
6.7 System Material Balance	30
6.8 Amount of Briquettes for Furnace (Energy Balance)	32
6.9 Process Data for Typical Production Plant	33
6.10 Electrical Power Input	34

7.	PROCEDURE FOR SETTING UP A BRIQUETTING PLANT	35
7.1	Initial Steps	35
7.2	Feasibility Studies	36
7.3	Project Implementation	36
7.4	Start-up Operation and Training	37
7.5	Manpower Requirements	37
8.	ECONOMIC ANALYSIS OF BRIQUETTING	39
8.1	Typical Cost Analysis	39
9.	APPLIANCES FOR BIOMASS BRIQUETTES	41
9.1	Combustion in Stoves	41
9.2	Combustion in Furnaces	41
9.3	Applications	42
10.	REFERENCES	43

1. INTRODUCTION

Many of the developing countries produce huge quantities of agro residues but they are used inefficiently causing extensive pollution to the environment. The major residues are rice husk, coffee husk, coir pith, jute sticks, bagasse, groundnut shells, mustard stalks and cotton stalks. Sawdust, a milling residue is also available in huge quantity. Apart from the problems of transportation, storage, and handling, the direct burning of loose biomass in conventional grates is associated with very low thermal efficiency and widespread air pollution. The conversion efficiencies are as low as 40% with particulate emissions in the flue gases in excess of 3000 mg/Nm³. In addition, a large percentage of unburnt carbonaceous ash has to be disposed of. In the case of rice husk, this amounts to more than 40% of the feed burnt. As a typical example, about 800 tonnes of rice husk ash are generated every day in Ludhiana (Punjab) as a result of burning 2000 tonnes of husk. Briquetting of the husk could mitigate these pollution problems while at the same time making use of this important industrial/domestic energy resource.

Historically, biomass briquetting technology has been developed in two distinct directions. Europe and the United States has pursued and perfected the reciprocating ram/piston press while Japan has independently invented and developed the screw press technology. Although both technologies have their merits and demerits, it is universally accepted that the screw pressed briquettes are far superior to the ram pressed solid briquettes in terms of their storability and combustibility. Japanese machines are now being manufactured in Europe under licensing agreement but no information has been reported about the manufacturing of European machines in Japan.

Worldwide, both technologies are being used for briquetting of sawdust and locally available agro-residues. Although the importance of biomass briquettes as substitute fuel for wood, coal and lignite is well recognized, the numerous failures of briquetting machines in almost all developing countries have inhibited their extensive exploitation.

Briquetting technology is yet to get a strong foothold in many developing countries because of the technical constraints involved and the lack of knowledge to adapt the technology to suit local conditions. Overcoming the many operational problems associated with this technology and ensuring the quality of the raw material used are crucial factors in determining its commercial success. In addition to this commercial aspect, the importance of this technology lies in conserving wood, a commodity extensively used in developing countries and leading to the widespread destruction of forests.

Biomass densification, which is also known as briquetting of sawdust and other agro residues, has been practiced for many years in several countries. Screw extrusion briquetting technology was invented and developed in Japan in 1945. As of April 1969, there were 638 plants in Japan engaged in manufacturing sawdust briquettes, known as 'Ogalite', amounting to a production of 0.81 MTY. The fact that the production of briquettes quadrupled from 1964 to 1969 in Japan speaks for the success of this technology. This technology should be differentiated from such processes as the 'Prest-o-log' technology of the United States, the 'Glomera' method in Switzerland and the 'Compress' method in West Germany.

At present two main high pressure technologies: ram or piston press and screw extrusion machines, are used for briquetting. While the briquettes produced by a piston press are completely solid, screw press briquettes on the other hand have a concentric hole which gives better combustion characteristics due to a larger specific area. The screw press briquettes are also homogeneous and do not disintegrate easily. Having a high combustion rate, these can substitute for coal in most applications and in boilers.

Briquettes can be produced with a density of 1.2 g/cm³ from loose biomass of bulk density 0.1 to 0.2 g/cm³. These can be burnt clean and therefore are eco-friendly and also those advantages that are associated with the use of biomass are present in the briquettes.

With a view to improving the briquetting scene in India, the Indian Renewable Energy Development Agency (IREDA) - a finance granting agency - has financed many briquetting projects, all of which are using piston presses for briquetting purposes. But the fact remains that these are not being used efficiently because of their technical flaws and also due to a lack of understanding of biomass characteristics. Holding meetings with entrepreneurs at different levels, providing technical back-up shells and educating entrepreneurs have to some extent helped some plants to achieve profitability and holds out hope of reviving the briquetting sector.

In other Asian countries although briquetting has not created the necessary impact to create confidence among entrepreneurs, recent developments in technology have begun to stimulate their interest. In Indonesia, research and development works (R&D) have been undertaken by various universities, the national energy agency and various research institutes since the mid-seventies. So far, these have mainly focussed on biomass conversion technologies. R&D works on biomass densification development are relatively rare. There are a number of export-oriented sawdust and coconut shell charcoal briquette producers. At present, densified biomass, particularly that which is not carbonized, is not a popular fuel in the country. A limited amount of smokeless charcoal briquettes, mostly imported, are consumed in some households of big cities. However, the prospects for the densified biomass industry in Indonesia, particularly where it is export oriented, seems to be good.

The Phillipine Department of Energy is currently promoting the development and widespread use of biomass resources by way of encouraging the pilot-testing, demonstration and commercial use of biomass combustion systems, as well as gasification and other systems for power, steam and heat generation. There is a limited commercial production of biomass briquettes in the country. At present nine commercial firms produce amounts ranging from 1 ton/day to 50 tons/day. Four pilot briquetting plants have stopped operation. Briquettes are produced from sawdust, charcoal fines and/or rice husk. In the Philippines the conversion cost from biomass to briquette is very high.

In Sri Lanka no briquetting projects have been implemented because of lack of exposure to the technology. But the prospects for substituting wood are high because the traditional sector relies heavily on fuel wood. The tea industry is the largest firewood consumer and it is supplied mainly from nearby rubber plantations or forests.

In Vietnam people have been involved in briquetting, but for limited uses. The briquettes are used basically for heating/cooking purposes and this is limited to households. The present non-commercial energy, mainly from biomass fuel, shares a great part of the total energy supply. R&D efforts should be undertaken to make briquetting technology economically profitable and socially acceptable to the public so that it might be widely adopted.

Briquetting plants with both small and high production capacities can be found in Thailand and, in general, plant performance in terms of profitability and management is encouraging. They have been successful in briquetting rice husk commercially. In other countries bottlenecks in the technology are the major reasons why briquetting is not popular. In Nepal small production capacity briquetting machines are currently operating and these can pave the way for large commercial production of briquettes which could make use of the huge quantity of agro-residues available in the country. In Bangladesh and Pakistan, although agro-residues are abundantly available, they are not used in briquetting.

Efforts have been made in Myanmar to reduce pressure on fuelwood and charcoal production. The government is providing support to state-run and private organizations to promote briquetting. The entrepreneurs, especially, are very much interested in briquetting of agro-residues and their utilisation.

India is the only country where the briquetting sector is growing gradually in spite of some failures. As a result of a few successes and IREDA's promotional efforts, a number of entrepreneurs are confidently investing in biomass briquetting. These entrepreneurs are also making strenuous efforts to improve both the production process and the technology.

Both national and international agencies have funded projects to improve the existing briquetting technology in India. Recently, the Indian Institute of Technology, Delhi in collaboration with the University of Twente, the Netherlands carried out research to adapt the European screw press for use with Indian biomass. The two major impediments for the smooth working of the screw press -- the high wear of the screw and the comparatively large specific power consumption required -- were overcome by incorporating biomass feed preheating into the production process.

The recent successes in briquetting technology and the growing number of entrepreneurs in the briquetting sector, are evidence that biomass briquetting will emerge as a promising option for the new entrepreneurs and other users of biomass.

2. POTENTIAL AGRO-RESIDUES AND THEIR CHARACTERISTICS

2.1. Potential Agri-residues

The potential agro-residues which do not pose collection and drying problems, normally associated with biomass are rice husk, groundnut shells, coffee husk and coir waste (obtained by dry process).

At present, loose rice husk, groundnut shells and other agro-residues are being used mostly by small scale boilers in process industries. Apart from being inefficient, these boilers do not have provision to capture fly ash and unburnt carbon, with the result that extensive air pollution is being created. In Ludhiana, one of the industrialised cities of Punjab (India), about 2,000 tonnes of rice husk is burnt every day.

This pollution problem has become so acute that the State Government of Punjab has banned the burning of loose husk in such boilers. It is very likely that other States in India will soon follow this policy. The users have been advised to use husk either as briquetted fuel or in fluidised bed boilers with proper pollution control measures.

As the number of industries is growing day by day, the energy required is also increasing proportionately and the present power supply is unable to meet the energy demand. To combat this energy shortage, developed as well as developing countries are putting more efforts into R&D to tap alternative energy sources. State policies are also being formulated to encourage alternative sources of energy. In India alone, it is proposed that 17,000 MW should be produced from biomass. Although other options like gasification can be used for power generation, briquetting of biomass can be considered for its economics, reliability and ease of operation. Briquettes of small size can be used in gasifiers for power generation. If the plant sites are chosen properly for easy availability of raw material, the agro-residues can be briquetted to reduce further transportation costs and associated pollution. This also improves the handling characteristics of biomass. The briquettes so obtained are very good fuels for local small scale industries and domestic purposes.

The basic use can be to substitute wood and coal thereby conserving natural wealth.

2.2. Appropriate Biomass Residues for Briquetting

There are many factors to consider before a biomass qualifies for use as feedstock for briquetting. Apart from its availability in large quantities, it should have the following characteristics:

Low moisture content

Moisture content should be as low as possible, generally in the range of 10-15 percent. High moisture content will pose problems in grinding and excessive energy is required for drying.

Ash content and composition

Biomass residues normally have much lower ash content (except for rice husk with 20% ash) but their ashes have a higher percentage of alkaline minerals, especially potash. These constituents have a tendency to devolatilise during combustion and condense on tubes, especially those of super heaters. These constituents also lower the sintering temperature of ash, leading to ash deposition on the boiler's exposed surfaces.

The ash content of some types of biomass are given in Table 2.1.

Table 2.1. Ash content of different biomass types

Biomass	Ash content (%)	Biomass	Ash content (%)
Corn cob	1.2	Coffee husk	4.3
Jute stick	1.2	Cotton shells	4.6
Sawdust (mixed)	1.3	Tannin waste	4.8
Pine needle	1.5	Almond shell	4.8
Soya bean stalk	1.5	Areca nut shell	5.1
Bagasse	1.8	Castor stick	5.4
Coffee spent	1.8	Groundnut shell	6.0
Coconut shell	1.9	Coir pith	6.0
Sunflower stalk	1.9	Bagasse pith	8.0
Jowar straw	3.1	Bean straw	10.2
Olive pits	3.2	Barley straw	10.3
Arhar stalk	3.4	Paddy straw	15.5
Lantana camara	3.5	Tobacco dust	19.1
Subabul leaves	3.6	Jute dust	19.9
Tea waste	3.8	Rice husk	22.4
Tamarind husk	4.2	Deoiled bran	28.2

The ash content of different types of biomass is an indicator of slagging behaviour of the biomass. Generally, the greater the ash content, the greater the slagging behaviour. But this does not mean that biomass with lower ash content will not show any slagging behaviour. The temperature of operation, the mineral compositions of ash and their percentage combined determine the slagging behaviour. If conditions are favorable, then the degree of slagging will be greater. Minerals like SiO_2 , Na_2O and K_2O are more troublesome. Many authors have tried

to determine the slagging temperature of ash but they have not been successful because of the complexity involved. Usually slagging takes place with biomass fuels containing more than 4% ash and non-slagging fuels with ash content less than 4%. According to the melting compositions, they can be termed as fuels with a severe or moderate degree of slagging.

Flow characteristics

The material should be granular and uniform so that it can flow easily in bunkers and storage silos. Some of the appropriate agro-residues are described below.

Rice husk

When compared to sawdust, agro-residues have a higher ash content, higher potash content and have poor flow characteristics. However, rice husk is an exceptional biomass. It has good flowability, normally available with 10 percent moisture and the ash contains fewer alkaline minerals, thereby it has a high ash sintering temperature. In fact, it makes an excellent fuel although its calorific value is less than wood and other agro-residues.

Other biomass materials

- Groundnut shell: Because of low ash (2-3%) and a moisture content less than 10%, it is also an excellent material for briquetting.
- Cotton sticks: This material is required to be chopped and then stored in dry form. It has a tendency to degrade during storage. Also, it has a higher content of alkaline minerals and needs to be used with caution.
- Bagasse/bagasse pith: These residues have high moisture content of 50% after milling, hence drying is energy intensive. They have low ash content and a correspondingly high heating value of the order of 4400 kcal/kg.

Pith is the small fibrous material which has to be removed from bagasse before bagasse is used as feedstock for making paper. Due to shortages of wood and increasing demand for paper and pulp, an ever increasing number of paper units are switching over to bagasse as feed material. The amount of pith available is almost equal to the tonnage of paper produced by a paper mill. For example, a 60 TPD mill will generate 60 TPD of bagasse pith. This material does not require milling before it is briquetted. At present, this pith is available from sugar mills at much lower costs. This is a potential material for briquetting.

- Coffee husk: An excellent material for briquetting having low ash and available with 10 percent moisture content. The material is available in the coffee growing areas of Karnataka and Kerala.
- Mustard stalks: Like cotton sticks, it is also an appropriate material for briquetting.
- Others: Other potential biomass residues suitable for briquetting are lentil stalks, sawdust, lantana camara in hilly areas, tea wastes, and coir pith.

3. FUNDAMENTAL ASPECTS OF BRIQUETTING

3.1. Pressure Compaction

Biomass densification represents a set of technologies for the conversion of biomass into a fuel. The technology is also known as briquetting and it improves the handling characteristics of the materials for transport, storing etc. This technology can help in expanding the use of biomass in energy production, since densification improves the volumetric calorific value of a fuel, reduces the cost of transport and can help in improving the fuel situation in rural areas. Briquetting is one of several agglomeration techniques which are broadly characterized as densification technologies. Agglomeration of residues is done with the purpose of making them more dense for their use in energy production. Raw materials for briquetting include waste from wood industries, loose biomass and other combustible waste products. On the basis of compaction, the briquetting technologies can be divided into:

- High pressure compaction
- Medium pressure compaction with a heating device
- Low pressure compaction with a binder.

In all these compaction techniques, solid particles are the starting materials. The individual particles are still identifiable to some extent in the final product. Briquetting and extrusion both represent compaction i.e., the pressing together of particles in a confined volume. If fine materials which deform under high pressure, are pressed, no binders are required. The strength of such compacts is caused by van der Waals' forces, valence forces, or interlocking. Natural components of the material may be activated by the prevailing high pressure forces to become binders. Some of the materials need binders even under high pressure conditions. Fig.2.1 shows some of the binding mechanisms.

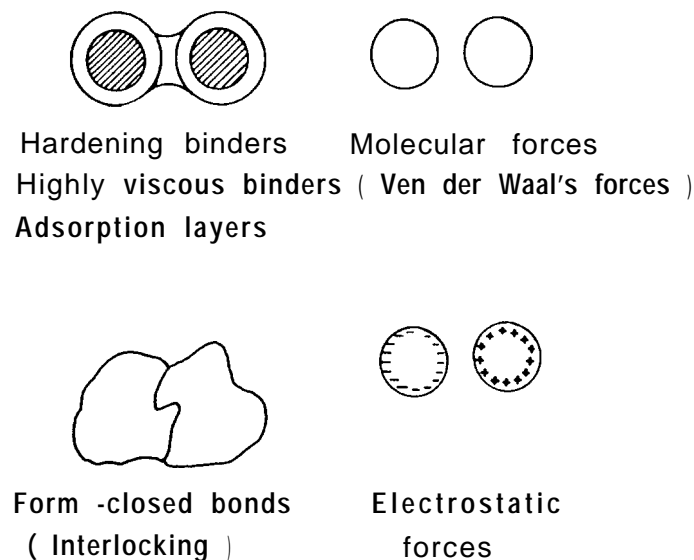

Fig. 3.1 Binding mechanisms

3.2. Binding Mechanisms of Densification

In order to understand the suitability of biomass for briquetting, it is essential to know the physical and chemical properties of biomass which also influence its behaviour as a fuel. Physical properties of interest include moisture content, bulk density, void volume and thermal properties. Chemical characteristics of importance include the proximate and ultimate analysis, and higher heating value. The physical properties are most important in any description of the binding mechanisms of biomass densification. Densification of biomass under high pressure brings about mechanical interlocking and increased adhesion between the particles, forming intermolecular bonds in the contact area. In the case of biomass the binding mechanisms under high pressure can be divided into adhesion and cohesion forces, attractive forces between solid particles, and interlocking bonds [1].

High viscous bonding media, such as tar and other molecular weight organic liquids can form bonds very similar to solid bridges. Adhesion forces at the solid-fluid interface and cohesion forces within the solid are used fully for binding. Lignin of biomass/wood can also be assumed to help in binding in this way. Finely divided solids easily attract free atoms or molecules from the surrounding atmosphere. The thin adsorption layers thus formed are not freely movable. However, they can contact or penetrate each other. The softening lignin at high temperature and pressure conditions form the adsorption layer with the solid portion. The application of external force such as pressure may increase the contact area causing the molecular forces to transmit high enough which increases the strength of the bond between the adhering partners. Another important binding mechanism is van der Waals' forces. They are prominent at extremely short distances between the adhesion partners. This type of adhesion possibility is much higher for powders. Fibres or bulky particles can interlock or fold about each other as a result forming interlocking or form-closed bonds. To obtain this type of bond, compression and shear forces must always act on the system. The strength of the resulting agglomerate depends only on the type of interaction and the material characteristics.

3.3. Mechanism of Compaction

In a screw extruder, the rotating screw takes the material from the feed port, through the barrel, and compacts it against a die which assists the build-up of a pressure gradient along the screw. During this process the biomass is forced into intimate and substantially sliding contact with the barrel walls. This also causes frictional effects due to shearing and working of biomass. The combined effects of the friction caused at the barrel wall, the heat due to internal friction in the material and high rotational speed (~600 rpm) of the screw cause an increase in temperature in the closed system which helps in heating the biomass. Then it is forced through the extrusion die, where the briquette with the required shape is formed. At this stage just before entering the die, the pressure exerted is maximum. If the die is tapered the biomass gets further compacted. Usually the die is heated for the smooth extrusion of the briquette. Some of the heat of the heated die is also transmitted to the biomass and the screw surface.

A simple extruder features three distinct zones: feed, transport, and extrusion zones. The important forces that influence the compaction of biomass play their role mostly in the compression zone. When the biomass is fed into a screw extruder and force is applied due to the restriction in the form of a die, compaction occurs due to the following mechanisms:

- Before reaching the compression zone (a zone usually formed by tapering of the barrel) the biomass gets partially compressed. This leads to closer packing and increased density. Energy is dissipated to overcome particle friction.
- At the compression zone, the biomass material becomes relatively soft due to high temperature (200-250 °C). In the process, due to loss of elasticity, it is pressed into void spaces and as a result, the area of interparticle contact increases. When the particles come together they form local bridges which selectively support and dissipate the applied pressure. Interlocking of particles may also occur. The moisture gets evaporated to steam at this stage and helps in moistening the biomass.
- The biomass gets further compressed in the tapering die (temperature 280 °C) to form the briquette. In this section, removal of steam and compaction take place simultaneously; the pressure exerted transmits throughout the material giving uniform pressure, and therefore, uniform density throughout the briquette.

In the compression zone the occluded air is pushed back to the feed section and thermal conductivity is improved due to compaction. During its passage through the compression zone the biomass absorbs energy from friction so that it may be heated and mixed uniformly through its mass. Brittleness, plasticity, and abrasivity are some of the important factors for pressure compaction.

The speed of densification determines the relative importance of the various binding mechanisms. The aim of compaction is to bring the smaller particles closer so that the forces acting between them become stronger which subsequently provides more strength to the densified bulk material. The product should have sufficient strength to withstand rough handling. If uniform pressure is not applied throughout the entire volume of the material, it causes variations in compact density in the product.

The properties of the solids that are important to densification are:

- flowability and cohesiveness (lubricants and binders can impart these characteristics for compaction)
- particle size (too fine a particle means higher cohesion, causing poor flow)
- surface forces (important to agglomeration for strength)
- adhesiveness
- hardness (too hard a particle leads to difficulties in agglomeration)
- particle size distribution (sufficient fines needed to cement larger particles together for a stronger unit).

4. BRIQUETTING TECHNOLOGIES

4.1. Screw Press and Piston Press Technologies

High compaction technology or binderless technology consists of the piston press and the screw press. Most of the units currently installed in India are the reciprocating type where the biomass is pressed in a die by a reciprocating ram at a very high pressure. In a screw extruder press, the biomass is extruded continuously by a screw through a heated taper die. In a piston press the wear of the contact parts e.g., the ram and die is less compared to the wear of the screw and die in a screw extruder press. The power consumption in the former is less than that of the latter. But in terms of briquette quality and production procedure screw press is definitely superior to the piston press technology. The central hole incorporated into the briquettes produced by a screw extruder helps to achieve uniform and efficient combustion and, also, these briquettes can be carbonised. Table 4.1 shows a comparison between a screw extruder and a piston press.

Table 4.1 Comparison of a screw extruder and a piston press

	Piston press	Screw extruder
Optimum moisture content of raw material	10-15%	8-9%
Wear of contact parts	low in case of ram and die	high in case of screw
Output from the machine	in strokes	continuous
Power consumption	50 kWh/ton	60 kWh/ton
Density of briquette	1-1.2 gm/cm ³	1-1.4 gm/cm ³
Maintenance	high	low
Combustion performance of briquettes	not so good	very good
Carbonisation to charcoal	not possible	makes good charcoal
Suitability in gasifiers	not suitable	suitable
Homogeneity of briquettes	non-homogeneous	homogeneous

The piston presses which are currently operating in India are also known as ram and die technology. In this case the biomass is punched into a die by a reciprocating ram with a very high pressure thereby compressing the mass to obtain a briquette. The briquette produced is 60 mm in external diameter. This machine has a 700 kg/hr capacity and the power requirement is 25 kW. The ram moves approximately 270 times per minute in this process.

The merits and demerits of this technology are:

- There is less relative motion between the ram and the biomass hence, the wear of the ram is considerably reduced.
- It is the most cost-effective technology currently offered by the Indian market.
- Some operational experience has now been gained using different types of biomass.
- The moisture content of the raw material should be less than 12% for the best results.
- The quality of the briquettes goes down with an increase in production for the same power.
- Carbonisation of the outer layer is not possible. Briquettes are somewhat brittle.

In the screw press technology, the biomass is extruded continuously by a screw through a taper die which is heated externally to reduce the friction.

The merits and demerits of this technology are:

- The output is continuous and the briquette is uniform in size.
- The outer surface of the briquette is partially carbonized facilitating easy ignition and combustion. This also protects the briquettes from ambient moisture.
- A concentric hole in the briquette helps in combustion because of sufficient circulation of air.
- The machine runs very smoothly without any shock load.
- The machine is light compared to the piston press because of the absence of reciprocating parts and flywheel.
- The machine parts and the oil used in the machine are free from dust or raw material contamination.
- The power requirement of the machine is high compared to that of piston press.

At present, screw press and piston press technologies are becoming more important commercially. As the piston press technology is comparatively older than the screw press technology, more piston presses are operating today in India. However, as screw press technology is also rapidly gaining in importance, this document will give greater emphasis to the screw press. The lack of basic research to improve the piston press and the manufacturers' inability to understand the technology are the two prime reasons why these presses are not performing satisfactorily on a commercial basis. Entrepreneurs face many problems due to frequent wear in the ram and the die. The life of the ram has been observed from 33 to 300 hours [2]. This is the most frequently used briquetting equipment and is manufactured throughout the world. It consists of a fly wheel that operates a piston, which presses the material through a tapered die where the briquette is formed. But piston presses have not been successful due to a lack of understanding of the characteristics raw material which in turn affects machine design parameters like flywheel size and speed, crank shaft size and piston stroke length. The feeding mechanism also needs to be perfected, in this case according to the bulk density of the raw material [3].

While an appropriate technology is important for briquetting, the compaction characteristics of biomass also play a significant role.

4.2. Other Briquetting Technologies

Another type of briquetting machine is the hydraulic piston press. This is different from the mechanical piston press in that the energy to the piston is transmitted from an electric motor via a high pressure hydraulic oil system. This machine is compact and light. Because of the slower press cylinder compared to that of the mechanical machine, it results in lower outputs. The briquettes produced have a bulk density lower than 1000 kg/m³ due to the fact that pressure is limited to 40-135 kg/h. This machine can tolerate higher moisture content than the usually accepted 15% moisture content for mechanical piston presses.

Pelletizing is closely related to briquetting except that it uses smaller dies (approximately 30 mm) so that the smaller products are called pellets. The pelletizer has a number of dies arranged as holes bored on a thick steel disc or ring and the material is forced into the dies by means of two or three rollers. The two main types of pellet presses are: flat and ring types [3].

The flat die type features a circular perforated disk on which two or more rollers rotate. The ring die press features a rotating perforated ring on which rollers press onto the inner perimeter. Some of the technical features of both types are given below:

	Flat type	Ring type
Disk diameter (mm)	300-1500	250-1000
Track surfaces of rollers (cm ²)	500-7500	500-6000

Large capacity pelletizers are available in the range of 200 kg/h to 8 ton/h. Thus, pellet press capacity is not restricted by the density of the raw material as in the case of piston or screw presses. Power consumption falls within the range of 15-40 kWh/ton.

4.3. Compaction Characteristics of Biomass and Their Significance

In order to produce good quality briquettes, feed preparation is very important. Feed parameters are discussed in this section, as these play a practicable role in briquetting technology.

For densification of biomass, it is important to know the feed parameters that influence the extrusion process. For different briquetting machines, the required parameters of raw materials like their particle size, moisture content, temperature are different. These are discussed below.

Effect of particle size

Particle size and shape are of great importance for densification. It is generally agreed that biomass material of 6-8 mm size with 10-20% powdery component (< 4 mesh) gives the best results. Although the screw extruder which employs high pressure (1000 - 1500 bar), is capable of briquetting material of oversized particles, the briquetting will not be smooth and clogging might take place at the entrance of the die resulting in jamming of the machine. The larger particles which are not conveyed through the screw start accumulating at the entry point and the steam produced due to high temperature (due to rotation of screw, heat conducted from the die and also if the material is preheated) inside the barrel of the machine starts condensing on fresh

cold feed resulting in the formation of lumps and leads to jamming. That is why the processing conditions should be changed to suit the requirements of each particular biomass. Therefore, it is desirable to crush larger particles to get a random distribution of particle size so that an adequate amount of sufficiently small particles is present for embedding into the larger particles. The presence of different size particles improves the packing dynamics and also contributes to high static strength [4]. Only fine and powdered particles of size less than 1 mm are not suitable for a screw extruder because they are less dense, more cohesive, non-free flowing entities.

Effect of moisture

The percentage of moisture in the feed biomass to extruder machine is a very critical factor. In general, it has been found that when the feed moisture content is 8-10%, the briquettes will have 6-8% moisture. At this moisture content, the briquettes are strong and free of cracks and the briquetting process is smooth. But when the moisture content is more than 10%, the briquettes are poor and weak and the briquetting operation is erratic. Excess steam is produced at higher moisture content leading to the blockage of incoming feed from the hopper, and sometimes it shoots out the briquettes from the die. Therefore, it is necessary to maintain an optimum moisture content.

In the briquetting process water also acts as a film type binder by strengthening the bonding in briquettes. In the case of organic and cellular products, water helps in promoting bonding by van der Waals' forces by increasing the true area of contact of the particles. In fact, the surface effects of water are so pronounced that the success or failure of the compaction process solely depends solely upon the moisture content of the material. The right amount of moisture develops self-bonding properties in lignocellulosic substances [5] at elevated temperatures and pressures prevalent in briquetting machines.

It is important to establish the initial moisture content of the biomass feed so that the briquettes produced have a moisture content greater than the equilibrium value, otherwise the briquettes may swell during storage and transportation and disintegrate when exposed to humid atmospheric conditions.

Effect of temperature of biomass

By varying the temperature of biomass the briquette density, briquette crushing strength and moisture stability can be varied. In a screw extruder, the temperature does not remain constant in the axial direction of the press but gradually increases. Internal and external friction causes local heating and the material develops self-bonding properties at elevated temperatures. It can also be assumed that the moisture present in the material forms steam under high pressure conditions which then hydrolyses the hemicellulose and lignin portions of biomass into lower molecular carbohydrates, lignin products, sugar polymers and other derivatives. These products, when subjected to heat and pressure in the die, act as adhesive binders and provide a bonding effect "in situ". The addition of heat also relaxes the inherent fibers in biomass and apparently softens its structure, thereby reducing their resistance to briquetting which in turn results in a decreased specific power consumption and a corresponding increase in production rate and reduction in wear of the contact parts. However, the temperature should not be increased beyond the decomposition temperature of biomass which is around 300 °C.

Effect of temperature of the die

The distinctive feature of a screw type briquetting machine is that heat is applied to the die 'bush' section of the cylinder. This brings about two important operational advantages. The machine can be operated with less power and the life of the die is prolonged. Further, the surface of the briquette is partially carbonized/torrified to a dark brown color making the briquette resistant to atmospheric moisture during storage. The temperature of the die should be kept at about 280-290 °C. If the die temperature is more than the required one, the friction between the raw material and the die wall decreases such that compaction occurs at lower pressure which results in poor densification and inferior strength. Conversely, low temperature will result in higher pressure and power consumption and lower production rate.

Effect of external additives

The briquetting process does not add to the calorific value of the base biomass. In order to upgrade the specific heating value and combustibility of the briquette, certain additives like charcoal and coal in very fine form can be added. About 10-20% char fines can be employed in briquetting without impairing their quality.

Further, only screw pressed briquettes can be carbonized. When carbonized with additives in the briquette to make dense char coal, the yield is remarkably increased. However, depending upon the quality of charcoal and coal powder, various formulations can be evolved for optional results. In piston press technology the effect of particle size and moisture content is similar to that of the screw press. But in this case preheating of raw material is not employed and the die is not heated. In fact the die needs cooling for smooth briquetting.

4.4. Unit Operations

The above factors illustrate that biomass feed preparation is very important and forms an integral part of the briquetting process.

The unit operations of the piston press and the screw press are similar except where the latest development in screw press technology has been adopted, i.e., where a preheating system has been incorporated to preheat the raw material for briquetting to give better performance commercially and economically to suit local conditions. In the present piston press operating briquetting plants, the biomass is briquetted after pre-processing the raw material but no preheating is carried out.

Depending upon the type of biomass, three processes are generally required involving the following steps.

- A. Sieving - Drying - Preheating - Densification - Cooling - Packing
- B. Sieving - Crushing - Preheating - Densification - Cooling - Packing
- C. Drying - Crushing - Preheating - Densification - Cooling - Packing

When sawdust is used, process A is adopted. Process B is for agro- and mill residues which are normally dry. These materials are coffee husk, rice husk, groundnut shells etc.. Process C is for materials like bagasse, coir pith (which needs sieving), mustard and other cereal stalks. Full details of these processes are presented, with reference to the process flow sheet (Figure 4.1), in the following sections.

4.5. Briquetting Plant

The briquetting plant can be operated in two ways. In the first case while pre-processing the raw material, the temperature of the feed material is not considered. In fact, the temperature is not at all critical for the production of briquettes. But if we take into consideration the power consumption, the wear behavior of the screw and the temperature of the die, then the temperature of the raw material at the time of feeding to the screw extruder plays a significant role.

The capacity of the feed preparation section of the plant must match with the briquetting capacity of the machine. In a commercial plant, the feeding of the raw material to the flash dryer is done through a screw conveyor. Components of a typical flash dryer are an air heater and a fan to produce a flow of heated air upwards through a long vertical drying duct.

The material to be dried is introduced into the airstream by the feeder, and the hot air conveys the particles through the duct in a concurrent flow. The dried material is then passed through a cyclone to separate particles from air and transported into the collecting hopper. The storage hopper should be given adequate attention regarding its capacity and to ease the flow of the material. Bridging in the hopper may cause fluctuations in operating conditions and may also lead to a production halt. The dry material is then fed to the screw extruder through a screw conveyor for its briquetting. In the case of briquetting with preheating of biomass, the material is control fed to a preheater to heat it to a desired temperature.

4.6. Material Processing Equipment

A production plant has to be properly designed and engineered such that breakdowns and operational bottlenecks are minimal or thoroughly eliminated by a following proper preventive maintenance schedule. Material processing equipment plays a vital role in the smooth production of briquettes and any compromise on their quality to save on costs would be counter productive. At the same time, these should not be over-designed as this would increase the initial costs and make this technology economically unviable. With reference to the flowsheet (Fig.4.1) for an ideal production plant, these equipments are now described.

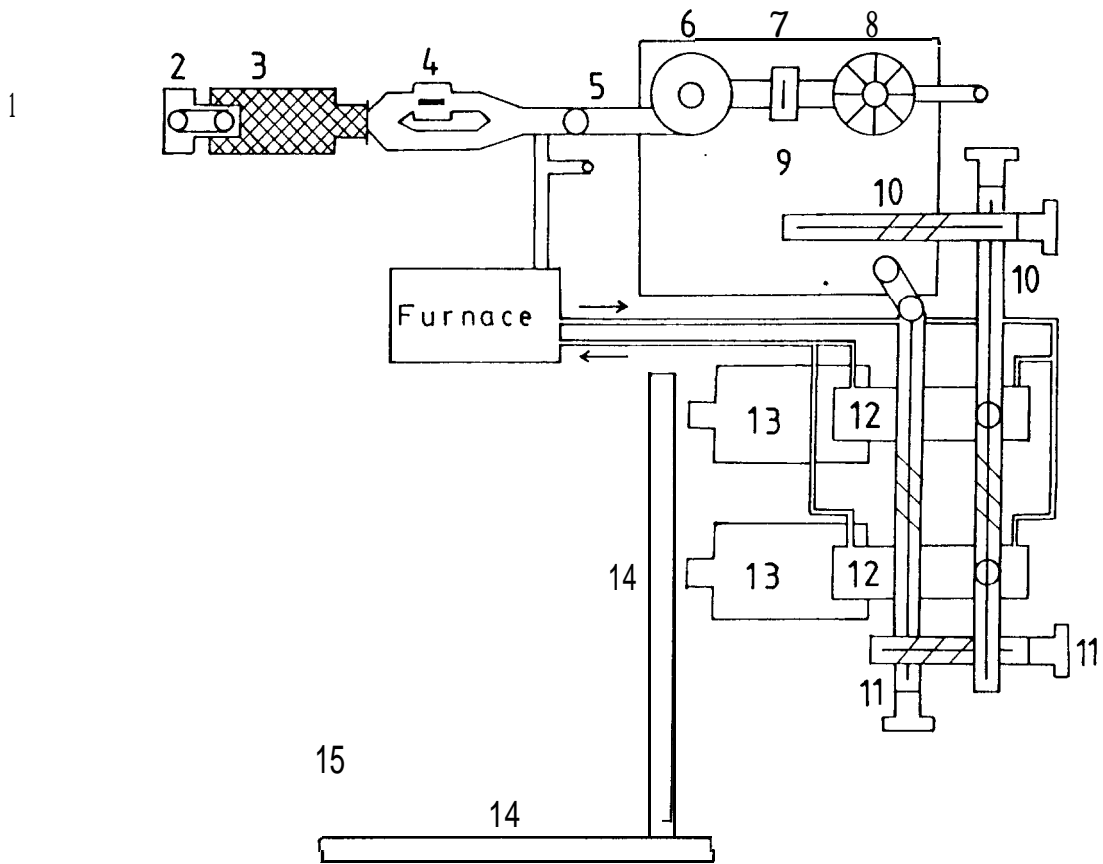

Fig.4.1 Process flow sheet

Raw material storage (1)

All biomass feeds are relatively very light with bulk densities ranging from 0.05 to 0.18 g/cc (50 to 180 kg/m³). Because of their bulky nature these are normally stored in the open. Where the location lies in heavy rain fall region, these should be stored in ground level bins which can be covered by heavy waterproof sheets or alternative, a side open shed could be provided. Depending upon the availability of supply, feed material for a 15 days to 3 months period should be stored at the plant site. It should be stored in a manner that the heaps are naturally aerated and heavy wind effects are minimised. About 3-4 sq. meter open space is needed to store one tonne of material.

Inclined screw feeder/Elevator (2)

The function of this screw is to feed the material from ground level to either the top feed end of a vibratory screen or the hammer mill.

A standard enclosed screw conveyor or elevator made in M.S. is most suitable for this operation. It can be custom built by numerous vendors. It should preferably have variable speed so that its capacity can be varied to match the capacity of related equipment.

Vibratory screen (3)

Screening of feed is essential for materials like sawdust which may contain many wooden cut pieces. These screens are standard items and available in many types and sizes. These should be of enclosed type to eliminate dust problems and preferably with a self cleaning arrangement having elastic balls. Various mesh sizes of screens can be used depending upon the type of material. For sawdust a screen of 10 mm may be used. For coffee husk, rice husk and groundnut shells, screens may be employed to avoid contamination by extraneous materials like stones and steel pieces etc. and the screen mesh should be based on the largest size of the feed.

Another advantage of using a vibratory screen is that it can also act as a control gravity feeder either to a hammer mill or a flash drier. For capacities greater than five tonnes/hour, rotating screens known as trommels may be employed.

Hammer mills (4)

Hammer mills are employed to reduce the particle size of the feed material. Except sawdust, bagasse pith, coir waste and other materials of similar size, all other materials should be crushed to 6-8 mm size with 10-20% fines to achieve optimum briquetting results. While many types of crushing and grinding equipments are available in the market, for biomass materials, hammer mills are considered the most suitable. These are available in various sizes from a few kg/hr to 10-15 TPH. Maintenance is rather routine and heavy in these machines and it is advisable not to operate these machines for more than 20 hours per day. Some hammer mills are symmetrical so the direction of the rotor can be reversed. In this case, more running time is possible without maintenance.

The output size is governed by the clearance between the lower end of the hammers and the housing and openings of cylindrical grating positioned beneath the rotor. It retains material until reduced to a size small enough to pass between the bars of the gratings. The impact parts are built using high chromium alloys to provide requisite wear resistance to abrasion and impact normally encountered on multiple hammers, casing and spherical grating or sieve. The speeds of these mills vary from 600-1500 rpm.

For biomass materials, it is essential to avoid gravity discharge from the hammer mills; instead, suction is produced by an induced draft blower to suck and convey the material pneumatically.

Basically, hammer mills are bought out items and are supplied complete with a pneumatic conveying discharge cyclone, a blower and dust separators by many vendors. Most of these vendors have pilot plant facilities to test new materials and then recommend an appropriate machine complete with rpm and power ratings of the motor. Typical prices for hammer mill cum conveying systems of capacity 1500 kg/hr, as quoted by manufacturers in India complete with cyclone, blower and dust collector, range from Rs.3.5 to 6 lac per system.

Dryers

As described earlier, drying is normally not required for materials like coffee husk, groundnut shells and rice husk. If feed is wet and drying becomes essential, integrated drying cum disintegration should be carried out by using the hot flue gases from the thermic fluid preheating furnace.

However, drying is essential for sawdust, wet coir pith, bagasse and bagasse pith and some other agro-residues like mustard stalk.

The types of drier employed for biomass materials are paddle indirect drier, flash, direct type, pneumatic or flash, and direct or indirect type rotary driers. Direct driers are those in which hot air or flue gases are intimately mixed with material and indirect ones are when heat is transferred to materials through a metallic surface and material is not mixed with the hot streams. Indirect driers are normally inefficient and require a large heat transfer area making the equipment bulky and expensive. Rotary driers are highly reliable but tend to be an order of magnitude more expensive than a flash drier, especially at a capacity less than 3-4 TPH. On the other hand, flash driers are highly suitable provided care is taken to avoid hot spotting within the system. This can easily be achieved by controlling the temperature and flow rate of hot steam and ensuring that there is no accumulation of solids at any stage of drying. Otherwise, as the material is highly combustible, a spontaneous fire might occur in the drier. For this reason, fluidised bed driers are not recommended.

Another main advantage of a flash drier over a rotary drier is that the former can simultaneously dry, disintegrate and convey the material.

Flash dryers (5)

Flash dryers are custom built equipment which can be supplied by many vendors who also have pilot plant facilities to test the material. It is recommended that one should purchase this equipment integrated with a hammer mill (if required), furnace, material handling, material collection system (6) necessary blowers (7) and dust collection bag filter assemblies (8). If the feed has a high moisture content, it is sometimes necessary to mix it with some dry finished product to improve its crushability and conveying properties.

All biomass materials are amenable to drying by flash driers with or without disintegration. Even though biomass materials are heat sensitive these can be satisfactorily dried at relatively high temperature because of short drying time. Most of the moisture is removed either in a disintegrator or at the entry point of the feed into the gas stream. Entry temperature of gases upto 300-400 °C can be conveniently employed even though the decomposition temperature of most biomass materials is between 250-350 °C. One precaution that must be taken is that sparks must not be allowed to proceed along with flue gases before gases are mixed with feed material. It is therefore essential to have a spark arrestor at the outlet of the furnace specially when solid fuels are deployed in the furnace.

Intermediate storage bin (9)

Once the feed material is sized and dried it is to be stored in an intermediate storage bin. It is important that this storage bin has a capacity of at least four hours of production. This is essential to isolate the two main sections of the briquetting plant viz. feed preparation and briquetting sections. In case of a short breakdown in either section, the production of the plant is not affected.

The bin design should be such that there is free flow of material and no bridging and choking of material should be allowed to take place. This bin is placed at ground level. If the bin is placed above ground level then the inclined portion of the screw is not required and the material can be gravity fed into the main material distribution screw feeder.

Main distribution screw feeder (10)

This is a standard screw feeder required to convey the material, fed by the screw feeder of the intermediate storage bin, and distribute it to the individual preheater attached to briquetting machines. The carrying capacity of this screw feeder should be at least 15-20 percent higher than the production rate of the briquettes. This is essential so as not to starve the feed to the machines. The excess material is discharged into a return feeder which conveys the material back into the intermediate bin. If multiple materials are required to be briquetted by the plant, it is advisable that this main screw feeder is fitted with a variable drive. This arrangement will ensure consistent supply to the briquetting machines.

Return feeder (11)

The function of this return feeder is to convey the excess material, not utilised by the machines, back to the intermediate storage bin. It could be either a straight overhead standard conveyor or could be an inclined conveyor discharging at the top portion of the intermediate bin.

After the briquettes are produced they need sizing and cooling before storage. The following sections describe the cutting and cooling of briquettes and also the equipment to control the fumes.

4.7. Briquette Storage

Once the pre-processed feed is introduced to the machine, the briquettes are extruded in a continuous length. They are then cut to the desired length. In a screw press, as the briquettes come out of a heated die, the temperature of the briquettes is very high, requiring them to be cooled before storage. There is also lot of associated steam and hot gases which escape through the hole of the briquette and a fume exhaust system is generally used to take these up to the atmosphere so that the briquetting site remains free from polluting gases and hot steam.

Piston press briquettes do not need cutting or cooling as they come out in small pieces produced by strokes and they are not hot. These briquettes come out of a water cooled die and can be immediately stored. There is also no associated steam or hot gases. The hot screw press briquettes are usually cooled over the conveying belt during their transportation to the storage

site. They are stacked length-wise and do not cause any fire hazard due to spontaneous combustion as is the case with heaps of agro-residues. The briquettes should be protected from water and it is ideal to store them under a shed.

Briquette Cutter

To cut the briquettes to the desired length there are two technological options.

One option is to provide an automatic circular cutter which will cut the hot extrudant into uniform lengths with smooth ends before these cut briquettes are allowed to fall on a cooling conveyor. This is desired if the briquettes are to be attractively packed in small bundles (6-10 briquettes) for sale through retail outlets (including supermarkets) as practiced in Europe.

The other option is to allow the extrudant to touch a smooth and inclined obstruction whereby it breaks due to the bending force. By this simple technique, fairly uniform lengths are produced but the edges are not smooth.

In case smooth edges are required, a bundle of 8-10 briquettes are taken to a separate twin saw cutter which can cut both sides simultaneously. This, however, results in the production of rejects in the form of small (20-30 cm thick) end cuts, which can be burnt in the furnace.

When briquettes are meant for firing in a boiler/furnace, it is not desirable to incorporate cutters of any type.

Cooling Conveyor (14)

Briquettes extruding out of the machines are rather hot with surface temperatures exceeding 200 °C. They have to be cooled and conveyed to the storage area. For this operation a perforated steel belt conveyor of suitable length is required. It is dangerous to allow hot briquettes to get stock piled in heaps near the machine because of their combustible nature. The outbreak of self-igniting fires are frequent unless precautions are taken to cool the briquettes before stacking them.

The width of this open belt conveyor should be at least 30 percent greater than the maximum length of the briquettes. The conveyor length should be a minimum of 5 meters but a greater length may be needed depending upon the proximity of the storage and packing area from briquetting presses.

Fumes Exhaust System

During their formation in the machine, the screw press briquettes have their surface partially pyrolysed, which imparts hydrophobic characteristics resulting in improved storability properties. But this desirable process also emits undesirable fumes. When hot, the briquettes also produce irritating fumes. In order to keep the working environment congenial for workers, a hood is provided near the outlet of the machine and part of the cooling conveyor such that these fumes are then led to the atmosphere through an exhaust pipe. The quantity of these fumes is very small (less than 0.02 percent of production by weight) but because of the higher temperature, the volume is still large enough to create a nuisance value. It is therefore, desirable to scrub

these fumes with circulating water before these are let out into the atmosphere. A simple system can be employed as shown in Fig.4.2. The water so contaminated can be sprinkled on the stored biomass stored in the open sun. The biomass will absorb all the organic constituents and water will evaporate during storage without undue wetting of the biomass. This will happen mainly because the quantity is very small compared to the amount of biomass.

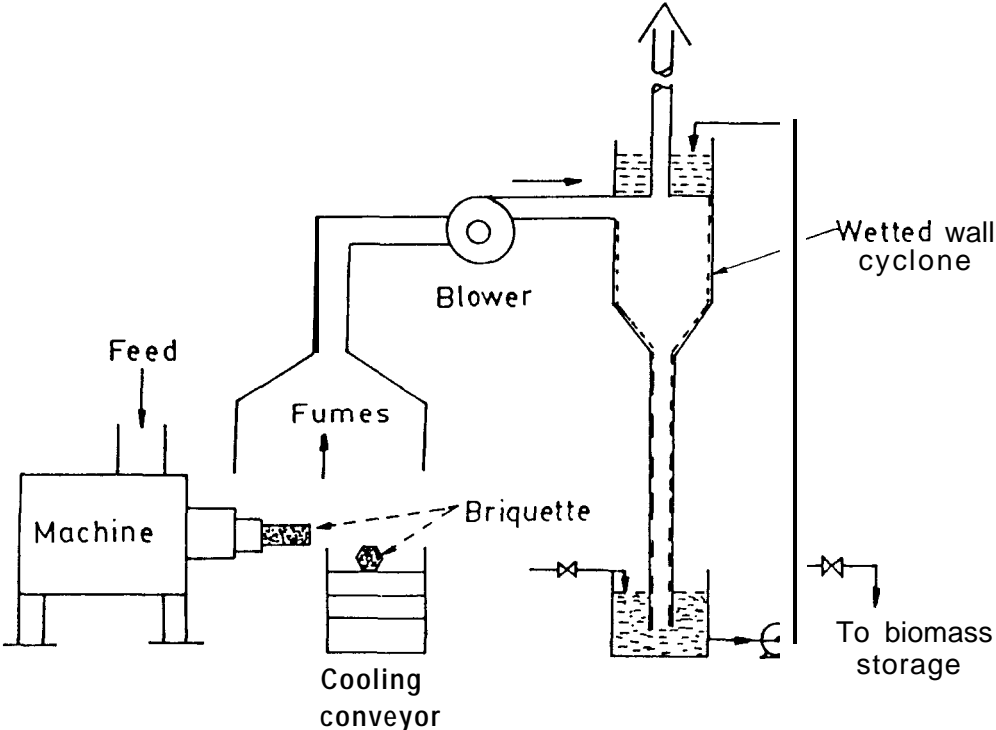

Fig.4.2 Fumes exhaust system

5. LATEST DEVELOPMENTS INCLUDING FEED PREHEATING

5.1. Essentials of Preheating

The briquetting of biomass has so far posed different problems in different kinds of machines and a standard procedure for each biomass has yet to be established. The main reason is the changing physico-chemical characteristics of different biomass or even for the same biomass grown under different agro-climatic conditions. For the purpose of large scale commercialization, it is, therefore, essential to study the behaviour of each biomass for its application in briquetting. For many years, methods of briquetting have been investigated and it is an established fact that typically very high power levels are required to form stable high density aggregates. This is true for piston, screw and roller type extrusion processes. This high pressure amounts to high electrical energy consumption and high wear rate of machine parts.

These were the precise reasons for the failure of a screw press supplied by Shimada, Japan which was tried on agro-residues when introduced into India in 1989 and installed at Karur (South India). In spite of the best efforts of the promoters and Shimada's engineers the machine could not be operated without excessive and uneconomic wear of the screw. In order to resolve this problem it was necessary to reduce the original resistance of the fibrous constituents of the biomass used for briquetting by preheating the feed material.

5.2. Preheating Phenomenon

Some of the studies [6,7,8] conducted earlier have revealed that the addition of heat benefits by relaxing the inherent fibers in the biomass and apparently softening its structure resulting in release of some bonding or gluing agent on to the surface. This phenomenon is also known as sweating the biomass. Reed et al [9] have also observed in laboratory scale experiments that the work requirement for densification can be reduced by a factor of about two by preheating the raw material. The results reported by Aga, S. et al [10] who have studied power consumption in the screw press briquetting of preheated sawdust at different die temperatures have established that the preheating lowers the power input.

This phenomenon of thermally induced softening the resistance of fibres is also noticed in the everyday domestic activity of ironing cotton clothes. Only when the press(iron) is hot enough can the fibres in the cotton clothes be oriented in the desired direction with minimum effort.

Once the biomass fibers are softened, a drop in resistance to briquetting results in: (a) reduced pressure required for briquetting, resulting in reduction in power consumption; (b) reduced frictional forces leading to a reduction of wear to contact parts, particularly the rotating screw; and (c) reduced resistance to flow leading to an enhanced rate of production.

Binderless densified briquetting is possible only at elevated temperatures of 250-300 °C under high pressure. Without preheating of feed, this temperature rise is basically attained by conversion of mechanical friction into heat energy. Once preheated feed is introduced, the mechanical energy required to elevate the substrate to the desired temperature reduces by partial input of thermal energy resulting in the above mentioned productivity benefits.

One can argue that even without feed preheating the temperature increases during briquetting, so the same effect of thermal softening of biomass should result in high productivity benefits. But there is one basic difference: without preheating, the temperature is elevated when the biomass is already under high pressure and it has no scope for expansion or loosening of fibre. The very fact that the preheating is done when the biomass is loose and not under pressure means that it can expand and become soft. It is like subjecting a spongy or cotton like material into a pressing operation with reduced resistance.

5.3. Preheater

A preheater has become an important and integral component of the screw press briquetting technology for agro-residues like rice husk etc. Experience gained during testing has shown that the technology is feasible only with preheating of biomass. Therefore, it is imperative that the unit should be properly designed so as to obtain the desired heating result and a trouble-free and smooth operation. This section deals with the design parameters and operational aspects of this equipment.

Selection of preheater

Between the two methods of heating ground and comparatively dry biomass, viz. direct and indirect, the equipments employing direct heat transfer such as pneumatic or fluidised bed are not at all suitable. Due to the combustible nature of the material they are prone to spontaneous combustion and/or decomposition of biomass.

Considering indirect methods, the choice is limited to either employing a high temperature heating medium or directly fired conveying equipment.

Direct fired conveyors for heating biomass have to be constructed using expensive materials (SS 316) but they are not very reliable due to uneven thermal stresses. Moreover, solid fired systems will give uncontrolled heating and firing of oil and gas for the briquetting industry is not only undesirable but uneconomical for developing countries who need briquettes to save fossil fuels. Therefore, the only choice is to deploy high temperature thermic fluid systems. The hot oil is heated in a separate solid fired furnace and then circulated around the conveyor to heat the biomass. One such system has been tested in a screw extrusion briquetting plant in India under a collaborative project between the Indian Institute of Technology, Delhi and the University of Twente, The Netherlands.

The feed preheating system consists of: (i) Thermic fluid system, (ii) furnace and (iii) feed preheater.

The equipments are described below.

Thermic fluid system

This system comprises of (a) circulating pump; (b) oil storage tank; (c) furnace; (d) piping, fittings and instruments.

These systems are being manufactured by many vendors in the country and thousands of such systems ranging from 1 lac to 45 lac kcal/hr capacity are deployed in chemical, milk processing and mineral processing industries where process heat at temperatures up to 250 °C are required. These heat transfer media are mineral oils manufactured and marketed in India by oil companies. These oils are stable up to 350 °C and are used for heat transfer applications. This oil is circulated between the heater/furnace and the process equipment and is a very convenient heating system requiring very little maintenance. The maximum outlet temperature of oil from the furnace is kept at 300 °C. However, for applications involving the heating of biomass, oil at a temperature of 200 °C should be adequate. Normally, thermic fluid heating systems employ furnaces fired with oil and gas, but solid fuel fired systems that utilise reject briquettes and other agro-residues and allow the operating costs to be drastically reduced are most suitable for biomass briquetting.

Oil circulating pump

The hot oil circulating pump is of centrifugal type and forms an integral part of the system. It has a mechanical seal which has to be cooled by circulating cold water once through; otherwise a water circulating pump is required to carry out this task.

Oil storage tank

This is also an integral part of the system and is a proprietary item but widely available. It can store at least 200 liters of oil, however its capacity depends upon the heat duty required, i.e., the number of briquetting machines employed in the plant. This tank is normally kept at an elevated level above the height of the furnace and utility equipment.

Piping, fittings and instruments

Inter connecting pipe work is needed to circulate the oil from the furnace to the preheater. These pipes are required to be insulated to prevent loss of heat. The instruments required are thermocouples at various positions and a multiple point temperature indicator mounted on a control panel.

Furnace

A furnace is required to: (a) heat the heat transfer oil to provide the necessary heat for preheating the biomass; and (b) provide flue gases in case drying of biomass is required.

The unit installed at the Faridabad site was engineered basically as an experimental facility. It worked on solid fuel for more than a year without any operational problems. It is suggested that the design of such furnaces should be carried out by the vendors supplying these thermic fluid heating systems as an integrated component. The information required by the vendor are the heat duty of the system and the calorific value of the fuel used. A solid fueled horizontal grate furnace is shown in Fig.4.3.

Constructional features of the preheater

Considering the above listed factors, the most appropriate biomass preheating system should include a horizontal and circular section of requisite diameter and length having a helical ribbon type agitator similar to the one used in a classical Swenson Walker type crystallizer. Such an agitator simultaneously mixes and transports the material. The biomass is heated in an annulus jacket through which hot thermic fluid is continuously circulated. The helical agitator should be as close to the heat transfer surface as mechanically possible so as to allow proper scraping of material close to the surface for better heat transfer.

The coil which is meant to circulate the oil in the furnace is specially designed. The oil gets heated in two sections of the furnace, i.e., the radiative and the convective zones. First, the oil enters into the coil placed in the convective zone and then goes to a portion of the coil in the radiative section. After the exit of the oil from the coil, its temperature depends upon the temperature of the furnace. The oil then goes to the preheater where the biomass gets heated up.

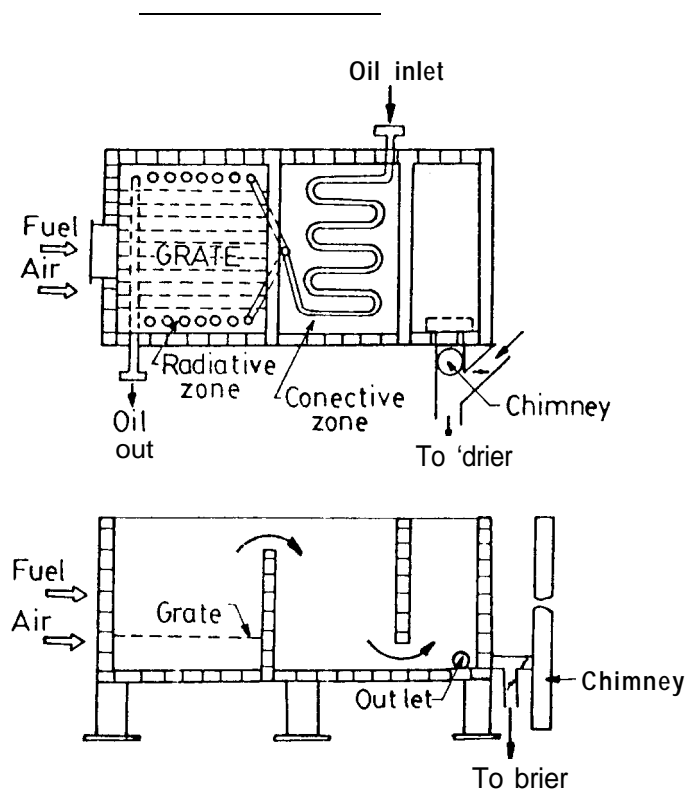

Fig.4.3 Layout of a furnace

The additional constructional features of this unit are: (i) vertical inlet and outlet pipes for the material; (ii) inlet and outlet ports for circulation of oil; (iii) air bleed valve for the jacket; (iv) outlet for moisture evaporated during heating; and (iv) baffle at outlet to maintain the level of the material inside the preheater. This is essential to ensure the maximum hold-up of the material which is required for enhanced heat transfer rates.

Design considerations

The preheater is designed on the basis of heat transfer considerations. The rate of heat transfer from hot oil to biomass is affected by individual transfer coefficients on the oil and biomass sides; and to some extent on the thermal resistance of shell thickness, but the controlling transfer resistance is on the biomass side. This is due to the low packing density and the refractory nature of biomass materials. This necessitates agitation and mixing of solids in a manner that the material near the hot surface is consistently removed and brought back into the bulk mechanically.

However, the mixing should not be very vigorous as a minimum contact time of solids with the hot surface is required to absorb the heat and also the power consumption would increase without any operational advantage. Furthermore, the internal diameter should not be very large, otherwise most of the material shall stay away from the annular heat transfer surface. If a large heat transfer area is required, the length of the preheater should be increased rather than its diameter. Moreover, as the shaft of the agitator is being supported at both ends, its length should not be increased too much so as to avoid its deflection in the middle where no simple bearing support can be provided. This is the precise reason that we cannot have one large preheater only to feed all the machines. Each briquetting machine should have its own preheater.

Considering these factors, a diameter of around 0.3 meter and a length of 3.5 meter is suggested with the helical agitator rotating at 1 O-l 5 r.p.m.

The analysis of the data obtained during the operation of the preheater is given in Table 5.1.

Table 5.1 Operational data on preheater

Material	Oil temp. °C		Biomass temp. °C		Production rate (kg/hr)	Heat transfer rate (kcal/hr)	Heat transfer coeff. (kcal/hr °C m ²)
	In	out	In	out			
Sawdust	170	160	40	80	360	9,936	30.4
Coffee husk	200	190	30	100	600	15,960	39.5
Groundnut shells	150	140	30	85	480	12,048	44.3
Rice husk	170	160	30	95	500	12,225	25.7

Preheater designs for production plant

As already mentioned in Sec. 53.3, as the controlling resistance to heat transfer is on the solid side, increasing the velocity of circulating oil will not make any significant contribution to increasing the heat transfer coefficient or decreasing the area. Therefore, the over-all heat transfer coefficient (HTC) given in Table 5.1 may be taken as the basis for designing a production unit. HTC as calculated varies from 25 to 44 kcal/hr.m² °C which is in conformity with the values of 15.50 given in the literature [11].

A production rate of 750 kg/hr was obtained from the following operational characteristics:

Production rate	= 750 kg/hr
Feed inlet temperature	= 30 °C
Feed outlet temperature	= 100 °C
Max. moisture evaporated during preheating	= 2 percent
Specific heat of feed	= 0.3
Oil inlet temperature	= 250 °C
Oil outlet temperature	= 240 °C
Overall HTC	= 30 Kcal/hr °C m ²

6. MATERIAL AND ENERGY BALANCE

6.1. Prerequisite Step

Before a material and energy balance can be carried out, it is first necessary to decide on an operating system to form the basis of the analysis. Such a system, representing an ideal briquetting plant, is presented in Fig.6.1.

6.2. Feed Processing (1)

The function of this system is to take the feed, process it and make it suitable for the preheater. Accordingly, this subsystem comprises sieving, grinding or drying or both (depending upon the raw material) storage and conveying to the feed preheater (2). During pre-processing there is a 1% loss of material and moisture is removed by hot flue gases from the furnace (4). This 1% loss of material is the maximum loss when efficient bag filters are employed. Further, the moisture content of the product should be 10%.

6.3. Preheater (2)

The function of this component is to heat the pre-processed feed to the desired temperature by circulating the heat transfer medium and, finally, to convey the preheated material to the briquetting machine (3). During this stage there is no material loss but some moisture is removed from the feed.

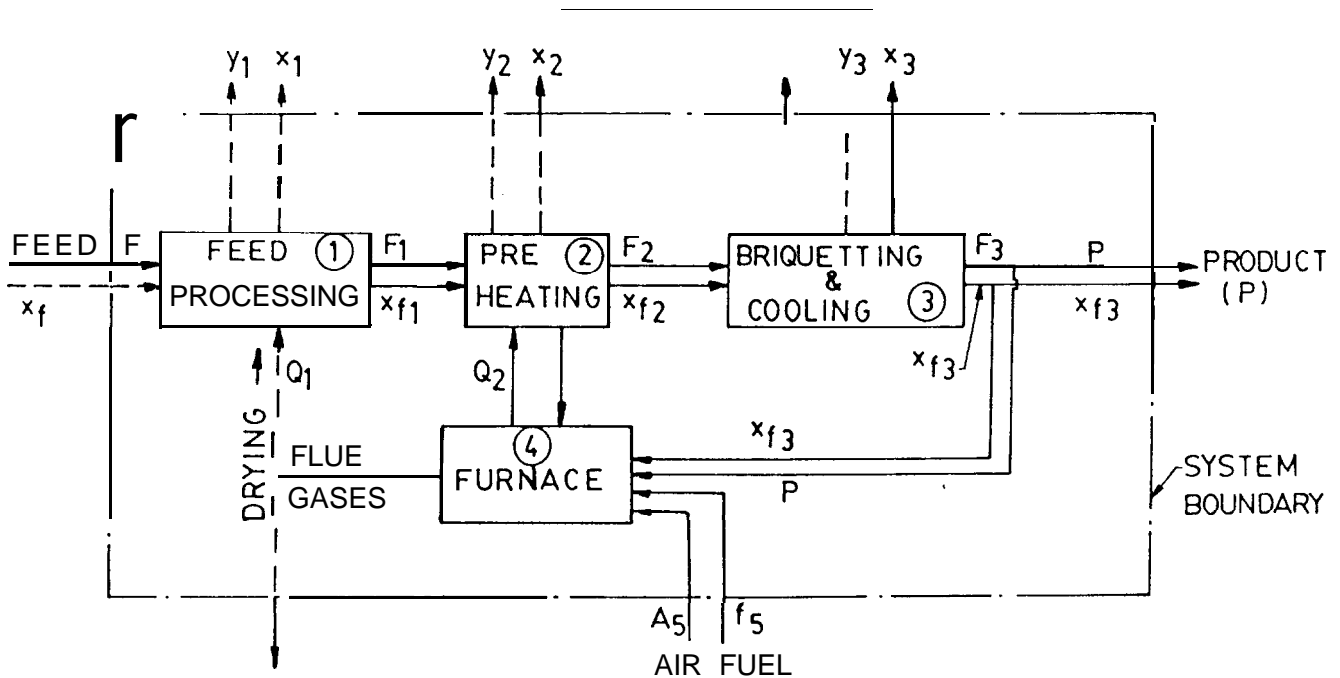

Fig.6.1 Ideal briquetting plant used to conduct material and energy balance

6.4. Briquetting and Cooling (3)

During briquetting and air cooling of the briquettes, moisture and a small quantity of material due to partial carbonisation of the briquette surface are lost along with heat during the cooling of the briquettes. A requisite fraction of these briquettes is used in the furnace to provide thermal energy.

6.5. Furnace (4)

Briquettes, along with some fresh raw biomass (mostly sieve oversized feed), are burnt along with air. A part of the heat produced is transferred to the preheaters and flue gases, in case required, are used for drying of feed in component (1). All the components require electrical energy inputs in order to carry out their operations but these inputs are not taken into consideration for a material and energy balance.

6.6. Information Flow Structure

An information flow diagram for a typical briquette production system is presented in Fig.6.2. In this structure, process information is passed from component to component of the processing system by variables common to several components. This transfer of information traces out the information flow structure of the system which provides a skeleton upon which we can organise the orderly computation for the material and energy balance and the design procedure for processing equipment.

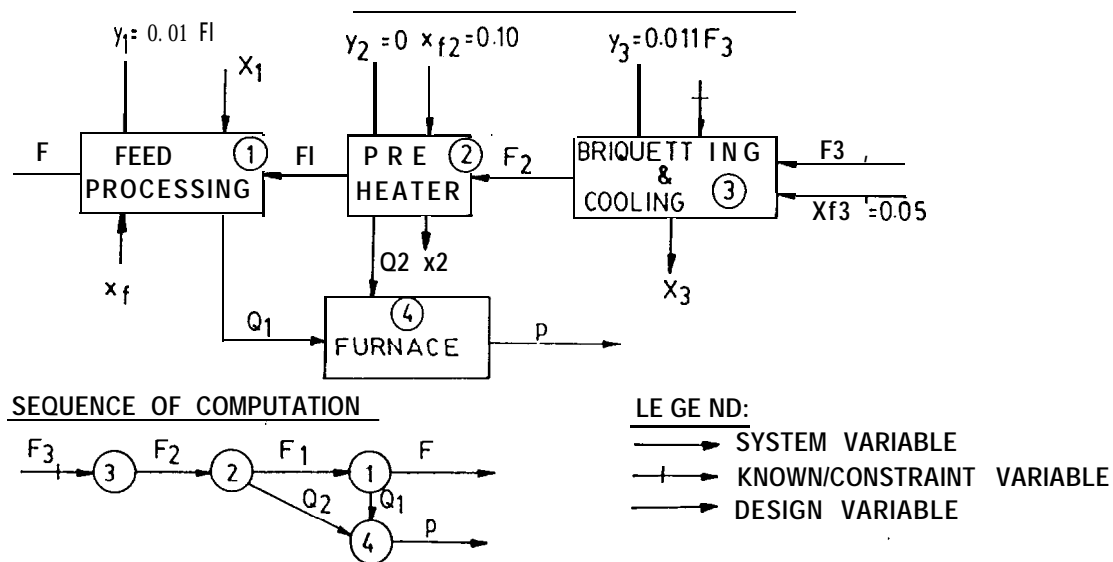

Fig. 6.2 Information flow diagram

This structure is entirely different from a flow sheet and the system synthesised in Fig.6.1. As shown in Fig.6.2 each arrow denotes information which must be fed from one block to another for the purpose of computation.

6.7 System Material Balance

With reference to Fig. 6.1 the overall material balance is given by the following equation:

$$F - \sum_1^3 X, Y - p = P \quad (\text{kg/hr})$$

where	F	=	feed rate with x_f moisture content
	$X_{1,2,3}$	=	moisture loss from components 1, 2 and 3
	$Y_{1,2,3}$	=	material loss from components 1, 2 and 3
	p	=	amount of briquettes used in furnace (This can be reduced to the extent of f_5 , an extra fuel instead of briquette)
	P	=	net production of briquettes
	$(x_f), (x_f)_1, (x_f)_2, (x_f)_3$	=	moisture content of different streams on wet basis

Feed processing subsystem (1)

Basis: F kg/hr of wet feed containing x_f fraction of moisture on wet basis.

Input = F with x_f moisture content

Assuming 1% loss of material at $(x_f)_1$ moisture content,
Output (F_1) = 0.99 (F - X_1) with $(x_f)_1$ moisture content

Loss of material = $Y_1 = 0.01$ (F - X_1) with $(x_f)_1 = 0.1$ moisture content,
where X_1 is the loss of moisture.

If x_f is 0.1, no drying is required. If $x_f > 0.1$ drying is required.

In the case of drying:

$$\begin{aligned} \text{Loss of moisture } X_1 &= x_f \cdot F - 0.1 (F - X) \\ X_1 &= (X_f - 0.1 F)/0.9 = F (1.11 x_f - 0.111) \end{aligned} \quad (6.1)$$

Where $x_f = 0.1$, then X_1 is equal to zero. This means no drying is required.

$$\begin{aligned} \text{Substituting the value of } X_1, \\ F_1 &= 1.0989 F (1 - x_f) \end{aligned} \quad (6.2)$$

Preheating Subsystem (2)

In this section the biomass is heated to about 60 °C. About 2% loss of moisture i.e. from 10% to 8% is expected.

Input (F_1) = 0.99 (F - X_1) with $(x_f)_1 = 0.1$ moisture content.

$$\text{Loss of moisture} = X_2 = F_1 \cdot (x_f)_1 - (F_1 - X_2) (x_f)_2 \quad (6.3)$$

$$\begin{aligned} F_1 &= 0.99 (F - X_1); (x_f)_1 = 0.1; (x_f)_2 = 0.08 \\ X_1 &= (1.11 x_f - 0.111) F \end{aligned} \quad (6.4)$$

Substituting these values in eqn 6.2,
 $X_2 = 0.0239 F(1-x_f)$

$$\begin{aligned} \text{Output } (F_2) &= 0.99 (F - X_1) - X_2 \\ \text{or, } F_2 &= 1.075 F(1 - x_f) \end{aligned} \quad (6.5)$$

Briquetting and cooling subsystem

During processing of biomass in this subsystem, the moisture is further reduced from 8% to 5% and 11 gm/kg of briquette material is converted into volatile fumes i.e., 1.1% loss of material having 5% moisture.

Input (F_2) = 1.075 F (1 - x_f)

$$\begin{aligned} \text{Loss of moisture } X_3 &= (x_f)_2 \cdot F_2 - (F_2 - X_3) (x_f)_3 \\ (x_f)_2 &= 0.08 \text{ and } (x_f)_3 = 0.05 \\ X_3 &= 0.034 F (1 - x_f) \end{aligned} \quad (6.6)$$

$$\begin{aligned} \text{Output } (F_3) &= F_2 - X_3 - 0.011 F_3 \\ \text{or, } F_3 &= (F_2 - X_3)/1.011 \end{aligned}$$

$$\text{Substituting the values of } F_2 \text{ and } X_3, F_3 = 1.0297 (1-x_f) F \quad (6.7)$$

Production: $P = F_3 - p$ (with $(x_f)_3 = 0.05$ moisture content), where p is the amount of briquettes used (if any) in the furnace.

Furnace(4)

One has the option to burn either the reject briquettes or large size wood/biomass in the furnace. Assuming that p kg/hr of briquettes having heating value of h kcal/kg are only used in the furnace, the value of p will depend upon whether heat produced is used only for preheating or both for preheating and drying of biomass. While heat from the furnace is transferred to the preheater (2) indirectly through hot oil as heat transfer medium, the drying is done directly by mixing flue gases with the feed biomass in the feed processing unit (1).

6.8 Amount of Briquettes for Furnace (Energy Balance)

Case I Preheating

The furnace is used only for preheating. The material is heated up to 100 °C and there is loss of moisture from 10% in feed to 8% in the product.

$$\begin{aligned} \text{Heat required in preheater} &= Q_2 = F_1 \cdot 0.37 (100 - 30) + X_2 \cdot 560 \\ [0.37 \text{ is the specific heat of biomass with 10\% moisture}] \\ \text{or, } Q_2 &= 25.9 F_1 + 560 X_2 \end{aligned}$$

$$\begin{aligned} \text{Substituting the value of } F_1 \text{ (Eqn. 6.2) and } X_2 \text{ (Eqn. 6.4) and } X_1 = 0.1, \\ Q_2 &= 37.68 F \end{aligned} \tag{6.8}$$

$$\begin{aligned} \text{Assuming 50\% heat going for preheating and the remaining 50\% accounted for by losses in flue} \\ \text{gases (40\%) and losses due to radiation in oil circulating system (10\%),} \\ \text{heat required in furnace, } Q_4 &= 37.68 F / 0.5 = 75.36 F \end{aligned} \tag{6.8.1}$$

$$\begin{aligned} \text{Assuming 90\% combustion efficiency of furnace which takes into consideration the radiation losses} \\ \text{from furnace and uncombusted fuel, the amount of briquettes required in furnace for preheating} \\ \text{having heating value of } h \text{ kcal/kg} \\ p &= 75.36 F / 0.9 h = 83.7 F/h \end{aligned} \tag{6.9}$$

Case II Preheating and drying

$$\text{Heat required for drying} = Q_1$$

$$\text{Feed} = F \text{ kg/hr; initial moisture} = x_1$$

$$\text{Final moisture} = 10\% \text{ or } (x_f)_1 = 0.1$$

$$\text{Surface temperature} = 50 \text{ }^\circ\text{C (according to plant data)}$$

$$\begin{aligned} Q_1 &= F(1-x_f) \cdot 0.3 \cdot (50 - 30) + x_f F (50 - 30) + 514 X_1 \\ &= \text{Dry feed sensible heat} + \text{Sensible heat of water} + \text{Latent heat} \end{aligned}$$

$$\text{Putting } X_1 = F(1.11 x_f - 0.111) \text{ in Eqn. 6.4, } Q_1 = F (584 x_f - 51)$$

This heat is needed in flue gases. Since flue gas heat is also available from preheating activity this must be deducted.

$$\begin{aligned} \text{Heat already available is 40\% of } Q_4, \\ \text{i.e., } 0.4 \times 7575.36 F &= 30.144 F \text{ (Eqn. 6.8.1)} \end{aligned}$$

$$\begin{aligned} \text{Net extra heat} &= F (584 x_f - 51) - 30.144 F \\ &= F (584 x_f - 81.144) \end{aligned} \tag{6.10}$$

Assuming 40% heat utilization for drying,
 heat required in flue gases = $F (1460 x_f - 202.8)$

Assuming 90% combustion efficiency and fuel with h kcal/kg heating value (as in Case I),
 amount of briquettes required for drying = $F(1460 x_f - 202.8)/0.9h$

$$O_r = F(1622.2 x_f - 225.3)/h \text{ kg/hr} \quad (6.10.1)$$

Amount of briquettes required both for drying and preheating (p),

$$p = F(1622.2 x_f - 225.3 + 83.70)/h$$

$$p = F(1622.2 x_f - 141.6)/h \text{ kg/hr}$$

6.11

6.9 Process Data for Typical Production Plant (For rice husk, coffee husk and groundnut shells having 10% moisture content)

No heat is required for drying.

Basis: Two machines of each 750 kg/hr (Briquette size 65 mm)

Production capacity, $F_3 = 1500$ kg/hr

Material and energy balance:

- Briquettes consumed ($CV = 4200$ kcal/kg) (Eqn. 6.9)
 $= (83.7 \times 1500)/h = 12550/4200 = 29.89 = 30$ kg/hr
- Net production = $1500 - 30 = 1470$ kg/hr
- Feed required (Eqn. 6.7), $F = F_3/1.0297 (1-x_f)$
 $F = 1618.6 = 1620$ kg/hr
- Thermal energy input (in the furnace)
 $= 4200 \times 30 = 1,26,000$ kcal/hr

For sawdust: Capacity = 1300 kg/hr from two machines of 65mm briquesttes, Table 6.1 gives the values of different operating parameters depending upon initial moisture content (x_f).

Table 6.1 Capacity/operating parameters for moist feed

Initial moisture fraction (x_f)	Briquettes for drying-preheating (kg/hr)	Raw material (kg/hr)	Saleable production (kg/hr)
0.15	32	1485	1268
0.20	57	1578	1243
0.25	82	1683	1218
0.30	107	1942	1193
0.40	157	2102	1143
0.50	207	2525	1093

6.10. Electrical Power Input

Power ratings of motors for 1.5 TPH of plant having two machines to produce 65 mm size briquettes from materials like rice husk, groundnut shells and coffee husk are given in Table 6.2.

Total power installed is 215 hp or 163 kW. With a utilization factor of 0.7, the power input into the plant is 114 kW. Assuming a 1.5 T/hr production rate, the electrical power input amounts to 76.2 kWh per tonne. However, during smooth briquetting operations, the die heaters are not in use for most of the time.

Table 6.2 Power ratings of equipment with estimated cost

Equipment	Number	Motor power rating (hp)	Cost (Rs. lac)
Screw feeder	One	2	0.50
Hammer mill	Two	50	4.00
Dryer	One	15	4.00
Silo with feeder	One	2	2.00
Main screw conveyor	One	3	1.00
Return feeder	One	2	1.00
Preheater	Two	6	2.00
Machines with heaters	Two	114	24.00
Cooling conveyor	One	3	2.00
Furnace	One		1.25
Fluid system	One	5	3.00
Fume exhaust	One	2	0.75
Auxiliaries		15	
Total	15	214 = 215	45

Assuming energy inputs for one tonne of briquettes having 4200×10^3 Kcal of intrinsic energy as:

Electrical = 76.2 kWh or 65,500 Kcal

Thermal = $20 \times 4200 = 84,000$ Kcal

The percentage of electrical energy input in briquetting = 1.5
in addition to thermal input = 2.0

7. PROCEDURE FOR SETTING UP A BRIQUETTING PLANT

7.1. Initial Steps

Before prospective entrepreneurs/industries decide to set up briquetting plants they should ensure the following prerequisites:

Need for briquettes

Assess the demand in the surrounding areas, specially in small/medium scale process industries, brick kilns, large bakeries, or institutes and restaurant establishments which are either using coal or oil. If the latter determine whether there is any provision to convert the existing oil firing system to a solid fuel firing system without high conversion costs. Original coal fired boilers/furnaces which were retrofitted to burn loose biomass are also potential users of briquettes, especially in those regions where pollution laws are rigidly enforced or statutory regulations prevent them from using loose biomass.

The economics of firing briquettes vis-a-vis coal are unfavorable. This implies that there is scope for substituting briquettes only in those areas which are remote from the coal fields.

Availability of biomass

Assess the quantity and type of biomass annually available within a reasonable (maximum 100 km) radius, the cost of transportation and the landed cost of raw material at site. Storage facilities either at site or at reasonably close locations should be assessed. The hazards of storing biomass for long periods and the potential loss of biomass due to winds or its biodegradation due to rains should be taken into account and incorporated into the cost of the raw material.

Potential manufacturers

Entrepreneurs who have either a captive market for briquettes or are generating their own biomass from agro processing industries or who can make briquetting plants as ancillary units to large industries have brighter prospects as successful briquette manufacturers. Second generation entrepreneurs also have a good chance of success as they can take advantage of the 100% depreciation incentive provided for briquetting projects in India.

Availability of infrastructure

Sufficient land, power and managerial capabilities are a prerequisite for setting up these units.

7.2. Feasibility Studies

Once the preliminary market survey establishes the potentials for sales and procurement of raw material, a project feasibility report has to be commissioned. A favorable report would reinforce the technical feasibility and economic viability of the project. A cost analysis and time based cash flow table would assist the entrepreneur to arrange for equity and commercial loans. The feasibility report is also needed for financial institutions and/or IREDA to make an assessment for loans. This feasibility report should be prepared by consultants having experience of briquetting technology.

7.3. Project Implementation

Once a decision is taken to set up the plant and the periodic flow of finances is arranged, the next activity is to initiate setting up the production unit.

The entrepreneur should approach the machine manufacturer and get firm quotations for plant and machinery. Preferably the project should be entrusted to a project management and execution company (PEC) on a turnkey basis. In this case the entrepreneur is sure of the production rate which will have to be guaranteed by the PEC.

In case some of the installations are to be carried out inhouse by the industry, the responsibility of either party should be clearly identified. In that case, the detailed engineering and installation drawings should be provided by the project execution company. Various jobs like foundation and civil works, electrical installation, structural construction and installation; installation of equipment and machines including piping, instrumentation and insulation etc. can be carried out by subcontractors either hired by the industry or project execution company. These jobs shall be executed as per drawings and specifications provided by the PEC.

For a typical briquetting plant, the equipment, except for the preheater and briquetting machines, is standard type which is widely manufactured.

If the industry decides to procure this equipment from competitive vendors it should be done only after final inspection and approval from the PEC.

This arrangement between the industry and PEC is to ensure that there is no mismatch of capacities between the feed preparation equipment, and material handling units on the one hand and the preheater and briquetting machines on the other. Further, this equipment has to be as reliable as the preheater and the briquetting machine which can be ensured by the PEC. This clause has to be emphasized as previous experience with ram type briquetting plants has clearly shown ancillary equipment to be unreliable. Moreover, a mismatch between feed preparation equipment and briquetting equipment has not been uncommon. This has resulted in low productivity, making the plants uneconomical and thereby bringing adverse publicity to the briquetting technology.

In most of the existing plants, the entrepreneur/industry has tried to procure underdesigned and poorly fabricated ancilliary equipment to save initial costs resulting in poor plant performance.

Therefore the emphasis should be placed on the reliability of ancillary equipment as well on the briquetting machines and for this the PEC should be authorised to provide the services on a turnkey basis.

It is also desirable to establish the plants on a BOT/BOOT basis. In this particular case the total responsibility right from commissioning to installation and operation for 1 year lies with the project management and the executing company.

7.4. Start-up Operation and Training

The normal start up period of a plant having 2-4 machines, should normally be 1-3 months before it is brought to the rated capacity. In addition, the operation of the plant for the next 3 months should be carried out under the supervision of a resident senior technician specifically trained for operation and maintenance of briquetting plants, before it is handed over to the owners. This period should be utilized to train the operators, welders and other technicians specifically recruited for the briquetting plant. Even after the plant is fully operational and all the bottlenecks have been attended to, active technical assistance for the next six months should be provided by the PEC. The briquetter and the PEC should have continuous contact with the manufacturer of the machines for consistent supply of spare parts especially replaceable screws, dies and change guide pipes. For the regular supply of screws, the local workshops may be commissioned to provide these.

7.5. Manpower Requirements

Both managerial and operations staff required for a briquetting plant depend upon the capacity of the unit and number of operating hours per day. As regards operating hours, it is absolutely essential that capacity utilization should be as high as possible. One would expect 85% capacity utilization with 300 working days in a year. Large units with more than 4 units may run 2 shifts/day and still make profits but the small units with 2 machines have to operate 20-22 hours/day. Further, small units having limited profitability cannot afford to hire the services of highly paid managers. Such units should be managed either by the entrepreneurs themselves or the services of existing management with the main industries (in case of ancillary unit) should be made available to the briquetting unit. As far as possible the supply of raw materials and the sale of briquettes should be sub contracted so that the entrepreneur/manager can concentrate their efforts solely on running the production unit.

Manpower requirement for a 2 machine unit having capacity to produce 1.3 to 1.5 tonnes/hour of briquettes are as follows:

Plant supervisor	One
Shift technicians	Three (1 for each shift)
Welder and maintenance technician	One
Electrician	One
Semi skilled machine operators	Three (1 in each shift)

Labourers:	
For feeding raw material	Six (2 each shift)
For storing briquettes	Six (2 each shift)
Accountant cum store keeper	One
Typist/data operator	One
Watchman (optional)	Two (preferably resident)
Casual labour	As and when required

The above listed staff are only indicative and actual deployment will depend on the specific location of the plant and degree of automation incorporated into the plant. For example, deployment of a small size loader would change the staffing pattern. If the feed is regularly produced by a main agro- industry, such as coffee curing or rice mills, a small feeding bin will eliminate the need for labourers feeding the raw material. All these functions have to be carefully considered in a project feasibility report and each report is highly site specific.

8. ECONOMIC ANALYSIS OF BRIQUETTING

Cost analysis of a briquetting plant is highly biomass and site specific and depends on the number of machines deployed in the plant. Therefore, it is imperative that a feasibility report should be prepared for each briquetting unit before its installation.

8.1. Typical Cost Analysis

A typical cost analysis with materials which are available in dry form and do not therefore require drying but do need grinding prior to briquetting is given below. The potential types of biomass under this category are rice husk, coffee husk and groundnut shells.

Capacity

Basis:

Two machines each 750 kg/hr

Production capacity = 1.5 T/hr (20 hrs/day operation)

Operating days per year	300
Operating hours per year	6000
Capacity utilization	85%
Raw material	8000 TPY
Moisture losses	350 TPY
Briquettes produced	7650 TPY
Briquettes consumed (Dryer)	600 TPY
Saleable production	7050 TPY

Infrastructural facilities

Power	1 5 0 kW
Land area	3000 m ²
Operational shed area	240 m ²
Briquetting storage (covered area)	250 m ²

Investments

	Rs.(lac)
Installed cost of plant & machinery (based on 9.0 lac for each machine)	52.0
Land	3.0
Building	4.2
Total investment	59.2
Working capital	7.5

Cost of production

	cost (Rs./tonne)
Power	136.70
Manpower	67.50
Water	8.00
Maintenance (including consumables)	76.70
Administrative overheads	43.00
Depreciation (Plant 10% Building 5%)	74.10
Subtotal	406.00
Financial cost	91.50
Cost of production	497.50 = Rs. 500/- per tonne
Overall cost of production per year	Rs. 38.25 lac

Profitability

Basis:		
Cost of raw material	=	Rs. 500/- per tonne
Net sale price of briquettes	=	Rs. 1450/- per tonne
		Rs.(lac)
Total sales	(1450 x 7050)	102.22
Production cost	(500 x 7650)	38.25
Raw material	(500 x 8000)	40.00
Gross profit before taxes		23.97
Pay-back period		2.5 years

The above analysis is based on a screw press costing Rs.9.0 lat. Plants with less than two machines are not recommended. However, plants with more machines will definitely have better profitability and advantages of scale of operation can be derived.

9. APPLIANCES FOR BIOMASS BRIQUETTES

Briquettes can be used in any appliances meant for burning wood or coal. However, certain changes in operating parameters especially regarding the distribution of primary and secondary air will have to be incorporated into the conversion.

One should first understand the specific characteristics of briquetted biomass before taking steps to make changes in appliances. Briquettes have a density twice that of common fuel wood. Porosity is very low and, accordingly, char produced during combustion is denser than wood or biomass charcoal. Moreover, screw pressed briquettes with a central hole have better combustibility than ram pressed solid briquettes and are considered to be better fuel than coal, wood and solid briquettes. This is mainly due to: (1) the larger surface area per unit weight or volume for the same size; (2) in spite of low porosity the effective thickness or resistance for release of volatiles is relatively much less and thus their flamability is much higher; and (3) char left after combustion is also twice as dense as wood and it burns slowly due to higher ash content. Since inventory of this char is much higher for the same thickness of bed, the briquettes have a higher heat capacity i.e., they retain heat for a longer period and keep the appliance at a higher temperature which then facilitates easy ignition of fresh fuel charges.

9.1. Combustion in Stoves

Solid briquettes (SB) are considered unsuitable for cookstoves and give excessive smoke unless broken into small pieces of 1-2 cm in thickness. Screw pressed briquettes (SPB) are easy to burn and give better combustion than wood. Since the density of these briquettes is higher than wood, the amount of air required is correspondingly greater for the same volume of briquettes. Moreover, SPB should be placed in a vertical position as far as possible so that the air can easily pass through the central holes. These can be broken into suitable sizes so as to fit well in the combustion chamber. The specific air requirement for these briquettes is about 1.6 Nm³/hour per kWh of heat output. For burning briquettes provision should be made to have side entry holes in the casing of stoves for ingress of secondary air. Alternatively, a hollow cylinder made out of a perforated sheet (holes size 3-5 mm) having diameter about 50 mm less than the inner diameter of stove can be placed in the stove chambers over the grate. The holes in this cylinder will facilitate the entry of distributed secondary air. This cylinder will also prevent the flame from touching the casing of the stove thereby conserving radiation losses.

9.2. Combustion in Furnaces

Both types of briquette are suitable for industrial furnaces which are meant for burning coal/wood but SPB fuels because of their homogeneous structure and configuration give much better performance than SB and other fuels. The power density is at least twice that of coal, provided secondary and primary air are properly distributed and the installed blowers supplying air have the requisite capacity.

SB fuels have a tendency to break during combustion and the resulting products depending upon size, either get entrained with gases or tend to pass through the grate into the ash pit or block the grate. This tends to reduce their combustion performance. SPB fuels, on the other hand, do not have these tendencies and give much better combustion performance.

While burning briquettes of either type, the operating parameters, especially with regard to distribution of primary and secondary air, have to be manipulated. Compared to coal these briquettes need more secondary and less primary air. When compared to wood, because of the higher density, the amount of air needs to be increased but its distribution components should be maintained at the original ratio. However, the specific consumption of total air in terms of $\text{Nm}^3/\text{hr.kWh}_t$ remains the same.

9.3. Applications

The briquettes are particularly recommended for:

Boilers:	For steam generation
Food processing industries:	Distilleries, bakeries, canteens, restaurants and drying etc.
Textile process houses:	Dyeing, bleaching etc.
Agro-products:	Tobacco curing, tea drying, oil milling etc.
Clay products:	Brick kilns, tile making, pot firing etc.
Domestic:	Cooking and water heating
Gasification:	Fuel for gasifiers
Charcoal:	Suitable for making charcoal in kilns

10. REFERENCES

1. Pietsch, W., Size enlargement by agglomeration, John Wiley & Sons Ltd., England, 1991.
2. Role of agro-residues in meeting energy demands in India, Singh, S.K. and D.K.Khare, Managing Bio-diversity for Energy, Publication on the World Food Day 1993]
3. Eriksson, S. and M. Prior, The briquetting of agricultural wastes for fuel, FAO Environment and Energy Paper 11, FAO of the UN, Rome, 1990]
4. Ludwig, C., How and why solids agglomerate, Chemical Engineering, 156-160, Jan'94.
5. Sen, K.C., Development of waterproof densified solid fuel pellet from forestry residues, Proceedings of the Sixth Canadian Bioenergy R&D Seminar held at Richmond, British Columbia, 16-18, Feb'87.
6. Reece, F.N., Temperature, Pressure and time relationships in forming dense hay wafers, Trans, A.S.A.E., 9, 749, 1966.
7. Buckingham, F., Hot news in hay wafering, Imp. Tract, 10, 30, 1963.
8. Osobone, V.I., Bricketinowanie sena i soloms nagrewaniem (Wafering of hay and straw with heating of the material), Mechanic, elektnfik, 26(9), 43, 1968.
9. Reed, T.B., Trefek, G, and Diaz, L., Biomass densification energy requirements in thermal conversion solid wastes and biomass, American Chemical Society, Washington D.C., 1980.
10. Aqa, S. and Bhattacharya, S.C., Densification of preheated sawdust for energy conservation, Energy, 17, No.6, 575, 1992.
11. Mc Cabe W.L. and J.C.Smith, Unit operations in chemical engineering, pp943, 1956.