

# STURGEON HATCHERY MANUAL



# Sturgeon Hatchery Manual

FAO  
FISHERIES AND  
AQUACULTURE  
TECHNICAL PAPER

# 558

Prepared by  
**Mikhail S. Chebanov**  
FAO Consultant  
Krasnodar, Russia

and

**Elena V. Galich**  
Krasnodar, Russia

Reprinted 2013

The designations employed and the presentation of material in this information product do not imply the expression of any opinion whatsoever on the part of the Food and Agriculture Organization of the United Nations (FAO) concerning the legal or development status of any country, territory, city or area or of its authorities, or concerning the delimitation of its frontiers or boundaries. The mention of specific companies or products of manufacturers, whether or not these have been patented, does not imply that these have been endorsed or recommended by FAO in preference to others of a similar nature that are not mentioned.

The views expressed in this information product are those of the authors and do not necessarily reflect the views of FAO.

ISBN 978-92-5-106823-6

All rights reserved. FAO encourages reproduction and dissemination of material in this information product. Non-commercial uses will be authorized free of charge.

Reproduction for resale or other commercial purposes, including educational purposes, may incur fees. Applications for permission to reproduce or disseminate FAO copyright materials and all other queries on rights and licences, should be addressed by e-mail to [copyright@fao.org](mailto:copyright@fao.org) or to the Chief, Publishing Policy and Support Branch, Office of Knowledge Exchange, Research and Extension, FAO, Viale delle Terme di Caracalla, 00153 Rome, Italy.

© FAO 2011

---

## PREPARATION OF THIS DOCUMENT

This document, the *Sturgeon Hatchery Manual*, was prepared in response to requests from the Central Asian and Caucasus region to the Food and Agriculture Organization of the United Nations (FAO). Fish farmers, hatchery operators, hatchery technicians and fisheries and aquaculture managers in the countries around the Caspian Basin expressed their need for a practical instruction manual containing the latest practices and knowledge on sturgeon hatcheries. This manual includes the latest available scientific research findings and experiences and compiles advice given in earlier manuals and handbooks on this subject. This document can be considered an update of the *Sturgeon Breeding and Rearing Handbook* (Chebanov, Galich and Chmyr, 2004), which was published only in the Russian language. It covers important aspects of sturgeon reproduction and growth for both sturgeon aquaculture and sturgeon restocking activities (with main emphasis on sturgeon culture as practiced in the region).

The preparation of this document was financed by the FAO Technical Cooperation Programme (TCP) project “Recovery of Sturgeon Population in Turkey: Habitat Assessment and Restocking” (TCP/TUR/3202). This project was a collaborative effort of FAO with the Ministry of Agriculture and Rural Affairs of Turkey (MARA), the State Hydraulic Works of Turkey (DSI) and the Central Fisheries Research Institute (SUMAE).

In the preparation process of this manual, input was received from experts attending the various workshops organized within the framework of the FAO Technical Cooperation Project TCP/INT/3101 “Capacity Building for the Recovery and Management of the Sturgeon Fisheries of the Caspian Sea”. These workshops included the FAO/World Bank/United Nations Development Programme (UNDP)/Ministry of Agriculture of the Republic of Kazakhstan “Regional Training Workshop on Sturgeon Hatchery Practices and Management” held in Atyrau, Kazakhstan from 14–19 April 2009, and the “Workshop on Technical Guidelines on Sturgeon Hatchery Practices and Management” held in Wuhan, China on 25 October 2009. The latter workshop was organized under a partnership of FAO with the World Sturgeon Conservation Society (WSCS), the 6th International Symposium on Sturgeon, the International Union for Conservation of Nature (IUCN) Sturgeon Specialist Group, the UNDP/Global Environment Facility (GEF) CaspEco project of the Caspian Environment Programme and the Institute for Hydro-Ecology of China. Additional information was collected for this manual from the WSCS meetings and the FAO/European Inland Fishery Advisory Commission (EIFAC) ad hoc Working Party “Management of Sturgeon” meetings over the period 2004–2009.

The preparation of this document was led by Mikhail S. Chebanov and Elena V. Galich of the South Branch Federal Center of Selection and Genetics for Aquaculture, Krasnodar, Russian Federation. Raymon van Anrooy of the FAO Sub-regional Office for Central Asia (SEC) coordinated the preparation of this document. Aquaculture (FIRA) and Marine and Inland Fisheries Services (FIRF) of the Fisheries and Aquaculture Resources Use and Conservation Division (FIR) of the FAO Fisheries and Aquaculture Department (FI) provided technical support and advice.



## ABSTRACT

This *Sturgeon Hatchery Manual* includes the latest available scientific research findings and experiences and compiles advice given in earlier manuals and handbooks on sturgeon culture and reproduction practices. This document can be considered an update of the *Sturgeon Breeding and Rearing Handbook* (Chebanov, Galich and Chmyr, 2004), which was published in the Russian language. The *Sturgeon Hatchery Manual* was prepared in response to numerous requests for practical guidance on this subject from the Central Asian and Caucasus region to the Food and Agriculture Organization of the United Nations (FAO).

This manual is targeted particularly at sturgeon farmers, sturgeon hatchery operators, hatchery technicians, and fisheries and aquaculture managers involved in sturgeon aquaculture development and the restocking and rehabilitation of sturgeon populations in the countries around the basins of the Black and Caspian seas. It aims to provide a practical handbook of modern sturgeon hatchery practices and management. The manual is available in the English, Russian and Turkish languages.

The manual starts with a chapter on the taxonomy, biology, distribution and life histories of Azov-Black and Caspian Sea sturgeons. Subsequent chapters discuss the following aspects of sturgeon hatchery practices: hatchery design, collection and transportation of wild broodstock, broodstock management, spawning and gamete processing, fry and fingerling rearing, production of live feeds, the technology of artificial reproduction, ecological- morphological and ethological-physiological express estimation of larval and fingerling (fry) viability, release of fingerlings into natural waterbodies, the formation of domesticated broodstock, basic sanitation and fish health measures, tagging, and early sexing and maturity determination in live sturgeons using ultrasound techniques. The manual also contains an extensive list of references, a list of Acipenseriformes and numerous figures, photographs and tables to support the guidance given on the various hatchery practices.

**Key words:** broodstock, gene pool, hatchery, reproduction, sturgeon, ultrasound

**Chebanov, M.S.; Galich, E.V.**

Sturgeon hatchery manual. *FAO Fisheries and Aquaculture Technical Paper*. No. 558. Ankara, FAO. 2011, 303 p.



## CONTENTS

<b>Preparation of this document</b> .....	iii
<b>Abstract</b> .....	v
<b>Abbreviations and acronyms</b> .....	xxvii
<b>Acknowledgements</b> .....	xxix
<b>Introduction</b> .....	xxxix
<b>Chapter 1 - Azov-Black and Caspian seas sturgeon taxonomy, biology, distribution and life history</b> .....	1
1.1 INTRODUCTION .....	1
1.2 BIOLOGY, DISTRIBUTION AND LIFE HISTORY .....	2
1.2.1 Beluga (giant sturgeon) – <i>Huso huso</i> (Linnaeus, 1758) .....	2
1.2.2 Russian sturgeon – <i>Acipenser gueldenstaedtii</i> Brandt & Ratzeburg, 1833 .....	4
1.2.3 Persian sturgeon – <i>Acipenser persicus</i> Borodin, 1897.....	8
1.2.4 Stellate sturgeon – <i>Acipenser stellatus</i> Pallas, 1771 .....	10
1.2.5 Atlantic sturgeon – <i>Acipenser sturio</i> Linnaeus, 1758 .....	13
1.2.6 Ship sturgeon – <i>Acipenser nudiventris</i> Lovetzky, 1928 .....	15
1.2.7 Sterlet – <i>Acipenser ruthenus</i> Linnaeus, 1758 .....	17
<b>Chapter 2 - Hatchery design</b> .....	19
2.1 BASIC REQUIREMENTS FOR HATCHERY DESIGN .....	19
2.2 MODERNIZED HATCHERY SCHEMES.....	21
2.3 SELECTION OF THE HATCHERY LOCATION .....	23
2.4 HATCHERY STRUCTURE .....	25
2.4.1 Unit for prespaw holding of broodstock.....	27
2.4.2 Broodstock long-term holding unit.....	28
2.4.3 Incubation unit .....	30
2.4.4 Pond unit.....	31
2.4.5 Live food production unit .....	31
2.4.6 Unit for adaptation of wild breeders to artificial holding conditions ..	32
2.4.7 Unit for broodstock development .....	32
2.5 HATCHERY WATER SUPPLY .....	32
2.6 WATER QUALITY REQUIREMENTS AT STURGEON HATCHERIES ....	33



---

2.7 RECOMMENDATIONS ON THE STRUCTURAL IMPROVEMENT OF EXISTING HATCHERIES.....	34
<b>Chapter 3 - Collection and transportation of wild breeders .....</b>	<b>35</b>
3.1 SITES AND PERIODS OF BREEDER COLLECTION .....	35
3.2 TRANSPORTATION OF BROODSTOCK TO HATCHERY.....	35
3.3 TAGGING OF WILD BREEDERS.....	36
3.4 MAIN BIOLOGICAL AND REPRODUCTIVE INDICES OF WILD BREEDERS.....	36
<b>Chapter 4 - Broodstock management.....</b>	<b>37</b>
4.1 INTRODUCTION .....	37
4.2 LATE AUTUMN ASSESSMENT .....	37
4.2.1 General considerations.....	37
4.2.2 Gonad maturity stages in sturgeons.....	38
4.2.3 Methods for broodstock preselection.....	40
4.2.4 Systematization of autumn assessment results .....	59
4.3 OVERWINTERING OF BREEDERS.....	60
4.3.1 Overwintering conditions .....	60
4.3.2 Overwintering water unit requirement.....	60
4.3.3 Stocking density of sturgeons intended for overwintering .....	61
4.4 SPRING EVALUATION OF GONAD MATURITY STATUS.....	62
4.4.1 Selection of mature males.....	62
4.4.2 Determination of spawnable females.....	62
4.5 DETERMINATION OF PRESPAWN HOLDING REGIMES FOR BROODSTOCK.....	68
4.5.1 Optimal prespaw holding of broodstock depending on oocyte polarization index.....	68
4.5.2 Assessment of broodstock spawnability on the basis of physiological and biochemical indices and regimes of prespaw holding.....	69
4.5.3 Prespawning correction of functional state of broodstock .....	71
4.6 HORMONAL INDUCTION OF SPAWNING.....	72
4.6.1 General recommendations on hormonal induction.....	72
4.6.2 General recommendations on injection .....	73
4.6.3 Pituitary preparation administration .....	74

4.6.4 Recommendations on synthetic analogue of mammalian gonadotropin-releasing hormone (GnRH <sub>a</sub> , Surfagon) injection administration.....	76
<b>Chapter 5 - Spawning and gamete processing</b> .....	79
5.1 OBTAINING MATURE GAMETES .....	79
5.1.1 Monitoring broodstock maturation .....	79
5.1.2 Extraction of ovulated eggs .....	81
5.1.3 Sedation of broodstock .....	85
5.1.4 Milt collection and hypothermal preservation.....	86
5.1.5 Sperm quality evaluation .....	88
5.1.6 Evaluation of egg quality.....	90
5.1.7 Artificial insemination of eggs.....	91
5.1.8 De-adhesion of eggs .....	93
5.2 EGG INCUBATION .....	95
5.2.1 Incubation systems.....	95
5.2.2 Norms for egg loading into incubation.....	100
5.2.3 Water demand for the incubation system.....	100
5.2.4 Illumination.....	101
5.2.5 Control of sturgeon egg incubation .....	101
5.2.6 Duration of embryogenesis.....	110
<b>Chapter 6 – Rearing of larvae, fry and fingerlings</b> .....	113
6.1 HATCHING AND HOLDING OF PRELARVAE.....	113
6.1.1 Hatching of prelarvae .....	113
6.1.2 Conditions of prelarval holding .....	114
6.1.3 Patterns of morphogenesis of the prelarval yolk sac .....	114
6.1.4 Specific peculiarities of phototaxis in sturgeon prelarvae .....	115
6.1.5 Important stages of postembryonic development .....	115
6.1.6 Prelarval behavioural traits during the period of endogenous feeding .....	117
6.1.7 Functional peculiarities of prelarvae during the period of transition to mixed feeding .....	119
6.2 REARING OF LARVAE .....	119
6.2.1 Transition to exogenous feeding.....	119
6.2.2 Feeding of larvae with live food.....	121
6.2.3 Peculiarities of tank rearing of larvae intended for release into natural waterbodies.....	123
6.2.4 Tank rearing of juveniles for broodstock replenishment .....	125

---

6.3 FINGERLING REARING IN PONDS .....	129
6.3.1 Pond dimensions .....	129
6.3.2 Preparation of ponds .....	130
6.3.3 Larval stocking densities in ponds.....	131
6.3.4 Establishment of feeding base and the application mineral fertilizers.....	132
6.3.5 Methods for elevation of the food base .....	132
6.3.6 Extermination of phyllopods (Phyllopora) .....	134
<b>Chapter 7 - Production of live food .....</b>	<b>137</b>
7.1 INTRODUCTION .....	137
7.2 CULTIVATION OF OLIGOCHAETES (ENCHYTRAEUS ALBIDUS) .....	137
7.3 CULTIVATION OF CLADOCERANS (DAPHNIA, MOINA).....	138
7.3.1 General requirements.....	138
7.3.2 Culture conditions.....	139
7.3.3 Nutrient value enhancement .....	140
7.4 CULTIVATION OF ARTEMIA SALINA.....	140
7.4.1 Incubation of Artemia cysts .....	140
7.4.2 Bioincapsulation of Artemia nauplii.....	141
7.4.3 Cultivation of Artemia in tanks.....	141
7.5 CULTIVATION OF CALIFORNIAN RED WORM (EISENIA FOETIDA).....	142
<b>Chapter 8 - Artificial reproduction of sturgeons based on the control of seasonality.....</b>	<b>145</b>
8.1 INTRODUCTION .....	145
8.2 COLLECTION OF BREEDERS .....	147
8.2.1 Methods for accumulation of wild breeders .....	148
8.3 TRANSITION OF BREEDERS TO SPAWNING TEMPERATURE REGIME (STR) .....	150
8.3.1 Russian sturgeon.....	150
8.3.2 Stellate sturgeon.....	151
8.4 REGIME OF EGG INCUBATION AND THERMAL ADAPTATION OF PRELARVAE.....	153
8.4.1 Egg incubation .....	153
8.4.2 Temperature adaptation of prelarvae .....	153

<b>Chapter 9 - Ecological-morphological and ethological- physiological express estimation of viability of sturgeon larvae, fry and fingerlings</b> .....	155
9.1 POLYFUNCTIONAL EVALUATION OF LARVAL AND FINGERLING FITNESS INDICES .....	155
9.2 <i>IN VIVO</i> ASSESSMENT METHODS: EXPRESS TESTS .....	155
9.2.1 Species-specific prelarval behavioural response to change the depth differential .....	156
9.2.2 Swimming capacity of sturgeon larvae and fry .....	157
9.2.3 Evaluation of the size and shape of yolk sac .....	158
9.3 ANAPHASE METHOD FOR COUNTING CHROMOSOMAL ABERRATIONS IN LARVAE .....	159
9.4 THE MELANOPHORES (PIGMENT CELLS) BACKGROUND RESPONSE.....	159
9.5 TERATOLOGICAL ANALYSIS OF LARVAE AND FINGERLINGS.....	162
9.6 PHYSIOLOGICAL AND BIOCHEMICAL EVALUATION OF THE STATE OF STANDARD HATCHERY-PRODUCED STURGEON JUVENILES .....	163
9.7 EVALUATION OF ADAPTIVE QUALITIES OF JUVENILES ON THE BASIS OF CENTRAL NERVOUS SYSTEM RESPONSE.....	164
9.8 NEURO-PHARMACOLOGICAL TESTING OF JUVENILES.....	166
9.9 FLUCTUATING ASYMMETRY AS A STATISTICAL INDICATOR OF JUVENILE VARIABILITY AND FOR ENVIRONMENTAL STRESS EVALUATION .....	167
<b>Chapter 10 - Release of fingerlings into natural waterbodies</b> .....	171
10.1 INTRODUCTION .....	171
10.2 METHODS FOR ENUMERATION OF RELEASED HATCHERY PRODUCTION.....	171
10.2.1 Overall count .....	171
10.2.2 Assessment count.....	171
10.3 RELEASE OF FINGERLINGS FROM PONDS .....	172
10.4 SELECTION OF OPTIMAL RELEASE SITES.....	172
10.4.1 Salinity tolerance of sturgeon juveniles as a criterion for release optimization .....	174
10.5 TRANSPORTATION OF FINGERLINGS TO RELEASE SITES .....	176

---

<b>Chapter 11 - The formation of domestic replacement and broodstock.....</b>	<b>179</b>
11.1 INTRODUCTION .....	179
11.2 GENETIC ASPECTS OF DOMESTIC BROODSTOCK FORMATION...	179
11.3 FISH FARMING AND BIOLOGICAL CRITERIA FOR BROODSTOCK ESTABLISHMENT .....	180
11.4 REARING OF BROODSTOCK IN CAGES .....	181
11.4.1 Types of cage .....	182
11.4.2 Cage rearing of fry and replacement stock .....	182
11.4.3 Cage holding of broodstock.....	183
11.4.4 Overwintering of fish in cages.....	184
11.5 PECULIARITIES OF BROODSTOCK HOLDING AND HANDLING ...	184
11.6 GENERAL RECOMMENDATIONS ON BUILDING BROODSTOCK SEXUAL STRUCTURE.....	188
11.7 BROODSTOCK BUILDING IN STURGEON PEDIGREE FARMS AND HATCHERIES .....	188
11.8 OPTIMUM TEMPERATURE CONDITIONS FOR STURGEON BROODSTOCK MANAGEMENT .....	189
11.8.1 Seasonal temperature regime for holding of senior replacement groups.....	189
11.8.2 Relationship between rate of sturgeon maturation and thermal regime of holding (sum of the effective temperatures) ..	193
11.9 MORPHOLOGICAL ABNORMALITIES IN DEVELOPMENT OF REPLACEMENT AND DOMESTIC BROODSTOCK .....	194
11.9.1 Abnormalities of the olfactory organs.....	194
11.9.2 Abnormalities of the eyes .....	195
11.9.3 Underdeveloped pectoral fins .....	195
11.9.4 Shortened opercula .....	195
11.9.5 Phenodeviations .....	196
11.10 GENERAL TESTING OF BROODSTOCK: GENETIC CONTROL OF BROODSTOCK MATERIAL .....	197
11.11 ADAPTATION OF WILD FISH TO ARTIFICIAL HOLDING CONDITIONS .....	198
11.11.1 Technological scheme of wild fish adaptation .....	198
11.11.2 Transition of wild fish to artificial feeds .....	199
11.12 TRANSPORTATION .....	201
11.12.1 Transportation in hermetic containers.....	201
11.12.2 Transportation of sturgeon fertilized eggs .....	202
11.12.3 Transportation in open containers.....	203

---

<b>Chapter 12 - Basic sanitary and fish health measures</b> .....	205
12.1 BASIC DISEASES OF STURGEON.....	205
12.2 CLINICAL SIGNS OF THE MOST COMMON DISEASES .....	206
12.3 METHODS FOR TREATMENT AND PREVENTION .....	208
12.4 PREPARATIONS USED FOR TREATMENT OF STURGEONS .....	209
12.5 USE OF ANTIBIOTICS .....	209
<b>Chapter 13 – Tagging</b> .....	211
13.1 TAGGING REQUIREMENTS .....	211
13.2 TAGGING WITH PIT TAGS .....	212
13.3 TAGGING WITH CWT TAGS .....	214
13.4 A FRAMEWORK FOR DEVELOPING AN INTERNATIONAL PROGRAMME OF TAGGING HATCHERY-PRODUCED STURGEON JUVENILES .....	215
<b>Chapter 14 - Early sexing and staging maturity in live sturgeons by using ultrasound techniques</b> .....	217
14.1 EQUIPMENT FOR ULTRASOUND DIAGNOSTICS OF SEX AND GONAD MATURITY STATUS IN LIVE STURGEONS .....	217
14.1.1 Characteristics of ultrasound waves .....	217
14.1.2 Transducers.....	218
14.1.3 Mobile data and analytical system based on the Mindray DP-6600 ultrasound scanner .....	219
14.1.4 Work place organization.....	221
14.2 USE OF SONOGRAPHY FOR EARLY DETERMINATION OF SEX AND GONAD MATURITY STAGE .....	222
14.3 ULTRASOUND GLOSSARY .....	223
14.4 ANATOMICAL STRUCTURE AND NONINVASIVE DETECTION OF INNER ORGANS AND TISSUES IN STURGEONS BY ULTRASOUND TECHNIQUE.....	224
14.4.1 Anatomical structure of inner organs.....	224
14.5 NONINVASIVE DETECTION OF ORGANS AND TISSUES BY ULTRASOUND TECHNIQUE.....	228
14.5.1 Scanning procedure schedule .....	228
14.5.2 Peculiarities of organ visualization at frontal ultrasound scanning .....	229
14.5.3 Peculiarities of organ visualization at transverse ultrasound scanning .....	231

---

14.6 EARLY SEXING AND STAGING MATURITY OF STURGEONS BY USING NONINVASIVE EXPRESS ULTRASOUND TECHNIQUE.....	232
14.6.1 Peculiarities of different stages of testicular development .....	232
14.6.2 Analysis of ultrasound images of ovaries at different maturity stages .....	245
14.6.3 Ultrasound images of testes and egg resorption .....	261
14.6.4 Noninvasive ultrasound monitoring of gonadogenesis of large sturgeon specimens.....	263
14.7 ULTRASOUND DIAGNOSTICS OF DEVELOPMENTAL ANOMALIES IN THE REPRODUCTIVE SYSTEM OF STURGEON (PATHOLOGIC ECHOANATOMY).....	265
14.7.1 Lobularity of testes .....	265
14.7.2 Cysts .....	266
14.7.3 Fatty degeneration of ovaries .....	267
14.7.4 Hermaphroditism .....	267
14.8 NONINVASIVE MEASUREMENTS OF LINEAR CHARACTERISTIC AND CALCULATION OF VOLUMETRIC PARAMETRS OF INNER ORGANS.....	268
<b>Annexes</b> .....	273
Annex I List of species of the Acipenseriformes .....	273
Annex II Design of the artificial spawning channel for seminatural reproduction of sturgeon .....	274
Annex III Relationship between $\tau_0$ and temperature for four sturgeon species .....	276
Annex IV Effective breeding number ( $N_e$ ).....	277
<b>RESOURCES</b> .....	279

## LIST OF FIGURES

<b>Figure 1:</b>	Caspian-stock adult beluga .....	2
<b>Figure 2:</b>	Azov-stock adult beluga from farmed broodstock of the South Branch Federal Center of Selection and Genetics for Aquaculture, Krasnodar, Russia .....	4
<b>Figure 3:</b>	Azov-stock adult Russian sturgeon.....	4
<b>Figure 4:</b>	A – Caspian-stock adult Russian sturgeon; B – Persian sturgeon; C – Azov-stock adult Russian sturgeon. ....	5
<b>Figure 5:</b>	Base of barbels close to mouth: A – Russian sturgeon; B – Persian sturgeon. ....	7
<b>Figure 6:</b>	Russian sturgeon from farmed broodstock of South Branch Federal Center of Selection and Genetics for Aquaculture, Krasnodar, Russia.....	8
<b>Figure 7:</b>	Caspian-stock adult Persian sturgeon. ....	9
<b>Figure 8:</b>	Adult Persian sturgeon from farmed broodstock of the South Branch Federal Center of Selection and Genetics for Aquaculture, Krasnodar, Russia. ....	9
<b>Figure 9:</b>	Caspian-stock adult stellate sturgeon.....	11
<b>Figure 10:</b>	A – Azov-stock stellate sturgeon; B – Caspian-stock stellate sturgeon; C – Danube-stock stellate sturgeon .....	11
<b>Figure 11:</b>	Azov-stock stellate sturgeon from farmed broodstock of the South Branch Federal Center of Selection and Genetics for Aquaculture, Krasnodar, Russia .....	12
<b>Figure 12:</b>	Atlantic sturgeon.....	13
<b>Figure 13:</b>	Ship sturgeon .....	15
<b>Figure 14:</b>	Ship sturgeon from farmed broodstock of South Branch Federal Center of Selection and Genetics for Aquaculture, Krasnodar, Russia .....	16
<b>Figure 15:</b>	Danube-stock sterlet .....	17
<b>Figure 16:</b>	Kuban-stock sterlet from farmed broodstock of South Branch Federal Center of Selection and Genetics for Aquaculture, Krasnodar, Russia .....	18
<b>Figure 17:</b>	Layout of technological scheme of hatchery .....	20
<b>Figure 18:</b>	Layout of a purpose-built sturgeon hatchery .....	21
<b>Figure 19:</b>	Example layout of fish hatchery of the multifunctional type.....	22
<b>Figure 20:</b>	Layout of sea sturgeon hatchery of the coastal type.....	23
<b>Figure 21:</b>	Don Sturgeon Hatchery (Azov Sea basin).....	24
<b>Figure 22:</b>	Bertyulsky Sturgeon Hatchery.....	25



<b>Figure 23:</b>	Layout of sturgeon hatchery (Iran) .....	26
<b>Figure 24:</b>	Pond facility of the “Kurinsky” type .....	28
<b>Figure 25:</b>	Layout of a unit with thermoregulation of water treatment.....	29
<b>Figure 26:</b>	Diagram of oxygen consumption intensity by sturgeons.....	30
<b>Figure 27:</b>	Common layout of an incubation unit .....	31
<b>Figure 28:</b>	Earthen ponds with their beds covered by a geomembrane .....	32
<b>Figure 29:</b>	Special live fish vessel “prorez” with many holes ensuring water exchange between the river and the vessel, with a tugboat beside it .....	35
<b>Figure 30:</b>	Autumn assessment of broodstock .....	38
<b>Figure 31:</b>	Instruments used for biopsy of sturgeon gonads in Russia.....	41
<b>Figure 32:</b>	A – Sampling of stellate sturgeon using biopsy probe, B – probe with sample of an ovary at maturity stage IV .....	42
<b>Figure 33:</b>	Egg sampling with the use of a catheter through a small abdominal incision.....	42
<b>Figure 34:</b>	Direct palpation of an ovary .....	43
<b>Figure 35:</b>	Example of suturing after laparoscopy application .....	44
<b>Figure 36:</b>	Laparoscopy.....	45
<b>Figure 37:</b>	Otoscope for direct examination of sturgeon gonads during laparoscopy.....	45
<b>Figure 38:</b>	Endoscopic system used for determination of sex and gonadal maturity status.....	46
<b>Figure 39:</b>	Sexing of immature sturgeon by introduction of borescope probe through an incision into the body cavity.....	47
<b>Figure 40:</b>	Endoscopic views of gonads of stellate sturgeon at different stages....	48
<b>Figure 41:</b>	Endoscopic view of oocytes .....	50
<b>Figure 42:</b>	Determination of sex steroids concentrations .....	52
<b>Figure 43:</b>	Plasma sex steroids and calcium (as index of vitellogenin) concentrations in mature and immature wild white sturgeon ( <i>Acipenser transmontanus</i> ) .....	52
<b>Figure 44:</b>	Fourier transform infrared spectroscopy .....	53
<b>Figure 45:</b>	Noninvasive SW-NIR spectral acquisition on anesthetized white sturgeon.....	54
<b>Figure 46:</b>	Set up for SW-NIR spectral analysis of eggs of white sturgeon....	55
<b>Figure 47:</b>	Method of sexing using urogenital region morphometry .....	56
<b>Figure 48:</b>	The scheme of craniological measurements.....	57
<b>Figure 49:</b>	Differences in urogenital opening shape .....	58
<b>Figure 50:</b>	Shape of pectoral fins in farmed Amur sturgeon specimens.....	59

---

<b>Figure 51:</b>	Overwintering ponds for captive sturgeon broodstock.....	60
<b>Figure 52:</b>	Pond for overwintering and holding of broodstock with sections for separate holding .....	61
<b>Figure 53:</b>	Spawning “dress” of different sturgeon species males.....	62
<b>Figure 54:</b>	A – biopsy of Russian sturgeon gonads (lateral view); B – biopsy of Atlantic sturgeon gonads (ventral view) .....	63
<b>Figure 55:</b>	Dissected view of an oocyte using a binocular microscope .....	63
<b>Figure 56:</b>	Layout view of dissected oocyte in sturgeon.....	64
<b>Figure 57:</b>	Oocytes with different polarization index (PI) values .....	64
<b>Figure 58:</b>	Equipment and materials for pituitary suspension preparation .....	73
<b>Figure 59:</b>	GnRHa injection administration .....	74
<b>Figure 60:</b>	Evaluation of ovulation rate in mature sturgeon female.....	80
<b>Figure 61:</b>	Schematic drawing illustrating the relative location of the ovaries and oviducts in the body of sturgeon.....	81
<b>Figure 62:</b>	Oviduct incision in farmed stellate sturgeon .....	82
<b>Figure 63:</b>	Stripping of stellate sturgeon eggs after oviduct incision.....	82
<b>Figure 64:</b>	Example of postsurgery suturing .....	84
<b>Figure 65:</b>	Postsurgery suturing .....	84
<b>Figure 66:</b>	Janet’s syringe and urethral catheter.....	87
<b>Figure 67:</b>	Milt collection.....	87
<b>Figure 68:</b>	Relationship between time of stickiness to substrate and ability to fertilize inseminated eggs .....	90
<b>Figure 69:</b>	Dividing eggs into portions intended for insemination .....	91
<b>Figure 70:</b>	Eggs insemination.....	92
<b>Figure 71:</b>	System for egg de-adhesion.....	94
<b>Figure 72:</b>	Manual egg de-adhesion .....	94
<b>Figure 73:</b>	Layout of one incubation box with eggs (Yuschenko system) .....	96
<b>Figure 74:</b>	Layout of the “Osetr” incubation system.....	97
<b>Figure 75:</b>	“Osetr” incubation system .....	97
<b>Figure 76:</b>	Modified “Osetr” incubation system .....	98
<b>Figure 77:</b>	Weiss incubation jars .....	98
<b>Figure 78:</b>	MacDonald jar system .....	99
<b>Figure 79:</b>	Layout of incubation jar systems .....	99
<b>Figure 80:</b>	Embryo at 2 <sup>nd</sup> –3 <sup>rd</sup> cleavage division .....	102
<b>Figure 81:</b>	Timing of sampling for fertilization rate determination for eggs in relation to incubation temperature.....	103

---

<b>Figure 82:</b>	Normal development of embryo at stages 16–17 .....	104
<b>Figure 83:</b>	Normally developed embryos at stages 26–28 .....	107
<b>Figure 84:</b>	Duration of development of the embryos of <i>A. gueldenstaedtii</i> (AG), <i>A. stellatus</i> (AS), <i>H. huso</i> (HH), <i>A. ruthenus</i> (AR), and the time of collecting samples for estimation of the normality of development as a function of temperature .....	108
<b>Figure 85:</b>	Formation of the neural plate in the presence of a plug of anomalous size .....	109
<b>Figure 86:</b>	Undevelopment of front body parts (absence of the prosencephalon) at stage 26 .....	109
<b>Figure 87:</b>	Abnormalities of heart rudiment formation .....	109
<b>Figure 88:</b>	Hatching prelarvae in circular plastic tanks .....	113
<b>Figure 89:</b>	Circular concrete tanks for prelarval holding (A) and plastic trays for larval grow out (B) .....	114
<b>Figure 90:</b>	Evaluation of beluga development rate (stage 42) .....	116
<b>Figure 91:</b>	Duration of Russian sturgeon prelarval development from mass hatching (stage 36) until the onset of exogenous feeding (stage 45) at 18 °C water temperature .....	117
<b>Figure 92:</b>	Typical behavioural response of sturgeon prelarvae-“swarming” ....	118
<b>Figure 93:</b>	Sample collected to assess quality of prelarvae .....	118
<b>Figure 94:</b>	Unit for rearing of sturgeon fry .....	123
<b>Figure 95:</b>	System of autofeeding .....	128
<b>Figure 96:</b>	Hatchery ponds for sturgeon fry rearing .....	130
<b>Figure 97:</b>	Ponds prepared for filling .....	131
<b>Figure 98:</b>	Boxes for oligochaete culture in special facility (unit) .....	137
<b>Figure 99:</b>	Concrete tanks for cladoceran ( <i>Daphnia</i> and <i>Moina</i> ) culture .....	139
<b>Figure 100:</b>	Layout for <i>Artemia</i> nauplius enrichment .....	141
<b>Figure 101:</b>	Californian red worm culture unit .....	142
<b>Figure 102:</b>	Unit for long-term holding of broodstock at low temperatures .....	146
<b>Figure 103:</b>	Scheme of year-round reproduction of different sturgeon species and ecotypes .....	146
<b>Figure 104:</b>	Protocol of temperature change to induce spawning state in wild sturgeon broodstock after long-term holding at low temperatures .....	151
<b>Figure 105:</b>	Outlines of the yolk sac in prelarvae of different sturgeon species at stage 36; lateral view .....	158
<b>Figure 106:</b>	The five-grade scale for assessment of the functional status of melanophores according to melanophore index value (mi) in sturgeon .....	160

<b>Figure 107:</b>	Experimental assessment of pigmental reactions in Russian sturgeon fry .....	161
<b>Figure 108:</b>	The “open space” test .....	164
<b>Figure 109:</b>	Release of sturgeon fingerlings into coastal sea area .....	174
<b>Figure 110:</b>	Specialized live-fish truck with containers providing optimal conditions for transportation of juveniles.....	176
<b>Figure 111:</b>	Transportation of sturgeon fingerlings to release sites using a special live-fish vessel .....	177
<b>Figure 112:</b>	System to control temperature and oxygen of transport water....	177
<b>Figure 113:</b>	Cages made of (A) fine-mesh nets (B) stainless steel .....	181
<b>Figure 114:</b>	Sturgeon cage complex (Bulgaria) .....	182
<b>Figure 115:</b>	Pontoon cages for broodstock holding .....	183
<b>Figure 116:</b>	Different hatchery units for sturgeon broodstock holding. A – small flow- through ponds; B – concrete tanks for holding breeders in a recirculating system .....	184
<b>Figure 117:</b>	Gonads of “mature” female Siberian sturgeon held under conditions of constant high temperature and feeding.....	190
<b>Figure 118:</b>	Optimal temperature regime for broodstock management of Russian sturgeon.....	191
<b>Figure 119:</b>	The age at puberty in cultured sturgeon females .....	191
<b>Figure 120:</b>	Abnormalities of the olfactory organs .....	194
<b>Figure 121:</b>	Underdevelopment of eye(s) .....	195
<b>Figure 122:</b>	Malformations of opercula (shortening).....	196
<b>Figure 123:</b>	Phenodeviants of the sterlet.....	196
<b>Figure 124:</b>	Examples of individual genetic passports .....	198
<b>Figure 125:</b>	A – loading container for short-term fish transportation (volume = 300 liter); B – specially designed container for short-term transportation of live fish .....	203
<b>Figure 126:</b>	Tags used for sturgeon .....	212
<b>Figure 127:</b>	Examples of PIT tags.....	212
<b>Figure 128:</b>	Marking with a PIT tag.....	213
<b>Figure 129:</b>	Portable hand-held detector for reading PIT tags.....	213
<b>Figure 130:</b>	The procedure of fry marking with CWT tags .....	214
<b>Figure 131:</b>	Detection of a coded wire micro-tag with the use of a special detector .....	215
<b>Figure 132:</b>	Ultrasound transducers .....	219
<b>Figure 133:</b>	Ultrasound portable scanning system Mindray DP-6600.....	220

---

<b>Figure 134:</b>	Mobile data and analytical system on the basis of the ultrasound scanner Mindray DP-6600.....	221
<b>Figure 135:</b>	Equipment of the mobile data and analytical system on the basis of the ultrasound scanner Mindray DP-6600.....	221
<b>Figure 136:</b>	Structure of inner organs of Siberian sturgeon.....	225
<b>Figure 137:</b>	Structure of the inner organs of Russian sturgeon.....	226
<b>Figure 138:</b>	Dissected views of the stomach.....	227
<b>Figure 139:</b>	Correct positioning of the transducer in the process of frontal scanning .....	228
<b>Figure 140:</b>	Correct positioning of the transducer at scanning in transverse plane.....	229
<b>Figure 141:</b>	View of organs and tissues location in the body cavity of Russian sturgeon male.....	230
<b>Figure 142:</b>	View of organ location in the body cavity of Russian sturgeon female .....	230
<b>Figure 143:</b>	View of organs location in the body cavity of the male Siberian sturgeon.....	231
<b>Figure 144:</b>	Ultrasound image of transverse section of ovary in Russian sturgeon female.....	232
<b>Figure 145:</b>	Testes at maturity stage I (M1) in male starlet .....	233
<b>Figure 146:</b>	Ultrasound images of testes in male sterlet at maturity stage I.....	233
<b>Figure 147:</b>	Testes of Russian sturgeon at maturity stage II (M2) .....	234
<b>Figure 148:</b>	Ultrasound images of frontal and transverse sections of testes in Russian sturgeon male at maturity stage II (M2).....	235
<b>Figure 149:</b>	Testis of Siberian sturgeon at maturity stage II semi-fatty (M2sf)....	236
<b>Figure 150:</b>	Ultrasound images of frontal and transverse sections of Siberian sturgeon male at maturity stage II semi-fatty (M2sf)....	237
<b>Figure 151:</b>	Testes of Russian sturgeon at maturity stage II fatty (M2f) .....	238
<b>Figure 152:</b>	Ultrasound images of frontal and transverse sections of Russian sturgeon male at maturity stage II fatty (M2f).....	239
<b>Figure 153:</b>	Testes of Siberian sturgeon at maturity stage III (M3) .....	240
<b>Figure 154:</b>	Ultrasound images of frontal and transverse sections of Siberian sturgeon male at maturity stage III (M3).....	241
<b>Figure 155:</b>	Testes of Russian sturgeon at maturity stage IV (M4).....	242
<b>Figure 156:</b>	Ultrasound images of frontal and transverse sections of Russian sturgeon male at maturity stage IV (M4) .....	243
<b>Figure 157:</b>	Ultrasound images of frontal section of sturgeon males during spawning (M5) .....	244

<b>Figure 158:</b>	Ovaries of sterlet at maturity stage I (F1).....	245
<b>Figure 159:</b>	Ultrasound images of frontal and transverse sections of ovaries in female sterlet at maturity stage I (F1) .....	246
<b>Figure 160:</b>	Ovaries of Siberian sturgeon at maturity stage II (F2) .....	248
<b>Figure 161:</b>	Ultrasound images of frontal and transverse sections of ovaries at maturity stage II (F2) .....	249
<b>Figure 162:</b>	Ovaries at maturity stage II semi-fatty (F2sf) in Russian sturgeon .....	250
<b>Figure 163:</b>	Ultrasound images of frontal section of ovary at stage II semi-fatty (F2sf) .....	251
<b>Figure 164:</b>	Ovaries of Russian sturgeon at maturity stage II fatty (F2f) .....	252
<b>Figure 165:</b>	Ultrasound images of frontal section of ovaries at maturity stage II fatty (F2f).....	253
<b>Figure 166:</b>	Ultrasound images of transverse section of ovaries at maturity stage II fatty (F2f).....	253
<b>Figure 167:</b>	View of ovary.....	254
<b>Figure 168:</b>	Ultrasound images of frontal section of ovaries at maturity stage II– III (F2– 3).....	254
<b>Figure 169:</b>	View of ovaries at maturity stage III (F3) in starlet.....	255
<b>Figure 170:</b>	Ultrasound images of frontal section of ovary at the end of maturity stage III and onset of stage IV (F3–4).....	256
<b>Figure 171:</b>	Ovaries of sterlet at maturity stage IV incomplete (F4i) .....	257
<b>Figure 172:</b>	Ultrasound images of frontal and transverse sections of ovary at the incomplete maturity stage IV (F4i).....	257
<b>Figure 173:</b>	Location of gonad in the body cavity of sterlet at maturity stage IV complete (F4c).....	258
<b>Figure 174:</b>	Ultrasound images of frontal and transverse sections of ovary at maturity stage IV complete (F4c) .....	259
<b>Figure 175:</b>	Ultrasound images of ovary at maturity stage V (F5) .....	259
<b>Figure 176:</b>	Ultrasound images of frontal section of ovaries 10 months post-extraction of ovulated eggs.....	260
<b>Figure 177:</b>	Ultrasound images of resorbed testes in post-spawn male .....	261
<b>Figure 178:</b>	Ultrasound image of female at stage VI (Fres) with eggs in the process of early resorption. A, B – enlarged areas of the ultrasound image.....	262
<b>Figure 179:</b>	Anaesthesia of a large Chinese sturgeon specimen (using MS-222 sedative).....	262
<b>Figure 180:</b>	Noninvasive ultrasound stress-free examination of sex and stage of a large specimen of Chinese sturgeon.....	263
<b>Figure 181:</b>	Ultrasound images of ovary of Chinese sturgeon female at maturity stage II fatty (F2f) .....	264

---

<b>Figure 182:</b>	Ultrasound images of the ovary of Chinese sturgeon.....	264
<b>Figure 183:</b>	Ultrasound images of frontal section of Chinese sturgeon males.....	264
<b>Figure 184:</b>	View of lobes of testis in Russian sturgeon .....	266
<b>Figure 185:</b>	View of cyst in the sturgeon body cavity .....	266
<b>Figure 186:</b>	View of fatty gonads in a mature Siberian sturgeon female reared under conditions of constant high temperature (15–23 °C) and feeding (A) and ultrasound image of frontal section of Siberian sturgeon ovary with fatty degeneration (B) .....	267
<b>Figure 187:</b>	Examples of automatic measurement of segments (L1-L3), perimeters (P) and surface areas (S) formed by closed circuit on the frontal (A) and transverse (B) ultrasound images of testis...	268
<b>Figure 188:</b>	Segmental division of ovaries into lobes at different maturity stages .....	269
<b>Figure 189:</b>	Automatic measurement of surface areas (Si) of transverse sections on separate segments of testis on the ultrasound image.....	269
<b>Figure 190:</b>	Examples of transverse ultrasound images of separate segments of Russian sturgeon ovary for measurement of surface areas (S1–S3) .....	270
<b>Figure 191:</b>	Measurement of an oocyte diameter (D1) on ultrasound image of frontal section of sterlet ovary .....	271

## LIST OF TABLES

<b>Table 1:</b>	Summary of the meristic characters of different Ponto-Caspian sturgeon species.....	3
<b>Table 2:</b>	Matrix of standard distances FST between populations of Russian sturgeon.....	5
<b>Table 3:</b>	Comparison of Russian sturgeon populations in terms of morphometrical indices .....	6
<b>Table 4:</b>	Water quality parameters .....	33
<b>Table 5:</b>	Main hatchery indices of wild breeders (at egg extraction).....	36
<b>Table 6:</b>	Classification of gametogenic stages in the white sturgeon .....	39
<b>Table 7:</b>	Comparison between females (F) and males (M) stages of maturity (1–6) in sturgeons.....	40
<b>Table 8:</b>	Variations in level of blood serum sex steroids in stellate sturgeon fingerlings at different stages of gonad development .....	51
<b>Table 9:</b>	Female grouping by oocyte polarization index (PI) and usage recommendations .....	65
<b>Table 10:</b>	Composition of SIS medium for incubation of ovarian follicles....	68
<b>Table 11:</b>	Regimes of prespaw holding of broodstock based on the oocyte polarization index (PI) .....	69
<b>Table 12:</b>	Recommendation on duration of prespaw holding of broodstock captured during spring spawning run.....	70
<b>Table 13:</b>	Physiological indices of wild breeders .....	71
<b>Table 14:</b>	Optimal temperature ranges (T, °C) for sturgeon egg incubation .....	72
<b>Table 15:</b>	Relationship between pituitary dose and water temperature .....	75
<b>Table 16:</b>	Relation between primary injection of pituitary dose and oocyte polarization index (PI) .....	75
<b>Table 17:</b>	Suggested GnRH $\alpha$ total dosage for induction of ovulation in sturgeon females .....	77
<b>Table 18:</b>	The latency time of sturgeon female maturation at different temperatures.....	79
<b>Table 19:</b>	Quantity of spermatozoa per cm <sup>3</sup> of ejaculate. ....	89
<b>Table 20:</b>	Duration of sperm ability to maintain fertilization rate under conditions of hypothermic preservation (d) depending on initial activity and time of motility preservation .....	89
<b>Table 21:</b>	Summary of recommendations on sturgeon egg de-adhesion .....	95
<b>Table 22:</b>	Norms for egg loading into the incubation system.....	100
<b>Table 23:</b>	Specific water inflow rates for the Yushchenko system.....	101



---

<b>Table 24:</b>	Specific water inflow rates for the “Osetr” system.....	101
<b>Table 25:</b>	Chronology of embryonic development in <i>A. gueldenstaedtii</i> <i>colchicus</i> .....	105
<b>Table 26:</b>	Duration of sturgeon egg incubation .....	111
<b>Table 27:</b>	Prelarval length and weight at hatch for different sturgeon species ....	113
<b>Table 28:</b>	Norms for prelarval stocking density in tanks and trays .....	114
<b>Table 29:</b>	Length and weight of sturgeon prelarvae at transition to exogenous feeding .....	120
<b>Table 30:</b>	Duration of sturgeon prelarval development before transition to exogenous feeding in relation to water temperature.....	120
<b>Table 31:</b>	The daily live food consumption rate .....	122
<b>Table 32:</b>	Feeding guidelines for Russian sturgeon ( <i>A. gueldenstaedtii</i> ) from fingerling size.....	125
<b>Table 33:</b>	Feeding guidelines for great sturgeon ( <i>H. huso</i> ) from fingerling size.....	126
<b>Table 34:</b>	Feeding guidelines for sterlet ( <i>A. ruthenus</i> ) from fingerling size.....	126
<b>Table 35:</b>	Relationship between particle size, frequency of fry feeding and fry weight .....	127
<b>Table 36:</b>	Stocking density for larvae, fry and juveniles in rectangular trays in nursery tanks .....	128
<b>Table 37:</b>	Growth rates of sturgeon fry in tanks at optimal temperatures.....	129
<b>Table 38:</b>	Standard larval stocking densities for different sturgeon species.....	131
<b>Table 39:</b>	Recommended volume of introduced inoculum of mature <i>Daphnia</i> sufficient for target daily harvest 0.2–1 kg of live <i>Daphnia</i> from the tank .....	140
<b>Table 40:</b>	Relation between freshwater demand and water temperature in tanks.....	149
<b>Table 41:</b>	Influence of holding duration at spawning temperatures (after long-term holding at low temperatures) on hatchery indices of female stellate sturgeon.....	152
<b>Table 42:</b>	Maximal intensity of “swim-up and drift-down movement” of prelarvae at various depths .....	156
<b>Table 43:</b>	Alteration of larval swimming capacity in a water current of 20 cm/s velocity.....	157
<b>Table 44:</b>	Abnormalities in sturgeon gametogenesis and early ontogeny.....	162
<b>Table 45:</b>	Summary of physiological state characters in viable “standard” hatchery-produced sturgeon juveniles .....	163

<b>Table 46:</b>	Chronological scheme of the “open space” test .....	165
<b>Table 47:</b>	Indices of locomotory activity of stellate sturgeon juveniles obtained from wild and farmed broodstock .....	166
<b>Table 48:</b>	The dynamics of motionlessness and restoration of physical activity in sturgeon fry (% of total number) anaesthetized by MS-222 at 50 mg/liter.....	167
<b>Table 49:</b>	Basic phases of sturgeon larvae, fry and fingerlings rearing under the regime of gradually increasing salinity (after transition to exogenous feeding) .....	173
<b>Table 50:</b>	Factorial mating of sturgeon .....	180
<b>Table 51:</b>	Number of fish necessary for broodstock replenishment .....	181
<b>Table 52:</b>	Fish stocking density in cages depending on the mean individual weight .....	183
<b>Table 53:</b>	Summary of standards for junior broodstock replacement rearing in tanks, cages and small ponds under optimal conditions .....	186
<b>Table 54:</b>	Summary of standards for senior replacement and broodstock rearing in tanks, cages and small ponds under optimal conditions .....	187
<b>Table 55:</b>	Minimal weight and age requirements for different sturgeon species, when their sex can be noninvasively identified by ultrasonography .....	189
<b>Table 56:</b>	Age at maturation and optimal time of replacement stock transition to natural temperature regime .....	190
<b>Table 57:</b>	Age at maturation and duration of successive cycles of gametogenesis in wild and farmed sturgeon breeders.....	192
<b>Table 58:</b>	A comparison of body weight at first maturity and absolute fecundity in wild and domestic sturgeon breeders.....	192
<b>Table 59:</b>	Reproductive indices in wild and domestic sturgeon breeders.....	193
<b>Table 60:</b>	Sum of the effective temperatures necessary for the first and the subsequent maturations of sturgeon females .....	193
<b>Table 61:</b>	Microsatellite loci applied for individual certification of sturgeon. ....	197
<b>Table 62:</b>	Requirements for the composition of paste-like feeds used for domestication of captive sturgeon broodstock.....	200
<b>Table 63:</b>	Loading densities for transportation of sturgeon larvae, fry and fingerlings in plastic bags .....	202
<b>Table 64:</b>	Norms for loading of sturgeon fertilized eggs for transportation in plastic bags at different temperatures .....	203
<b>Table 65:</b>	Stocking densities for sturgeons when using different transportation containers.....	204
<b>Table 66:</b>	Clinical signs of common sturgeon diseases .....	207

<b>Table 67:</b>	External clinical signs of some diseases in sturgeons and the degree of their manifestation (in points).....	208
<b>Table 68:</b>	List of veterinary and prophylactic preparations .....	209
<b>Table 69:</b>	Velocity of sound wave propagation ( $V$ ), density ( $\rho$ ) and resistance ( $Z=\rho V$ ) of different substances .....	218

## ABBREVIATIONS AND ACRONYMS

<b>AFLP</b>	Amplified fragment length polymorphism
<b>BMPs</b>	Better management practices
<b>BW</b>	Body weight
<b>CCP</b>	Common carp pituitary
<b>CFU</b>	Colony forming units
<b>CRH</b>	Constant regime of holding
<b>CSN</b>	Central nervous system CWT Coded wire tag
<b>DSI</b>	State Hydraulic Works of Turkey
<b>EIFAC</b>	European Inland Fishery Advisory Commission
<b>FA</b>	Fluctuating asymmetry
<b>FAO</b>	Food and Agriculture Organization of the United Nations
<b>FI</b>	Fisheries and Aquaculture Department (of the FAO)
<b>FIR</b>	Fisheries and Aquaculture Resources Use and Conservation Division (of the FAO)
<b>FRC</b>	Feed conversion rate
<b>FT-IR</b>	Fourier transform infrared spectroscopy
<b>GBD</b>	Gas bubble disease
<b>GEF</b>	Global Environment Facility
<b>GnRH<sub>a</sub></b>	Superactive synthetic analogue of mammalian gonadotropin-releasing hormone
<b>GVBD</b>	Germinal vesicle breakdown
<b>HUFA</b>	Highly unsaturated fatty acids
<b>IUCN</b>	International Union for Conservation of Nature
<b>LLTUHB</b>	Long-term low temperature unit for holding of broodstock
<b>LTR</b>	Low temperature regime
<b>MARA</b>	Ministry of Agriculture and Rural Affairs of Turkey
<b>MPC</b>	Maximum permissible concentration
<b>mtDNA</b>	Mitochondrial DNA
<b>PCA</b>	Principal component analysis
<b>PIT</b>	Passive integrated transponder (tag)
<b>RAPD</b>	Random amplified polymorphic DNA analysis
<b>SEC</b>	FAO Sub-regional Office for Central Asia
<b>SIS</b>	Siberian sturgeon (medium)
<b>SP</b>	Sturgeon pituitary
<b>SPGP</b>	Sturgeon pituitary glycerol preparation
<b>STR</b>	Spawning temperature regime

<b>SUMAE</b>	Central Fisheries Research Institute
<b>SW-NIR</b>	Short wavelength near infrared (spectroscopy)
<b>TCP</b>	Technical Cooperation Programme
<b>UNDP</b>	United Nations Development Programme
<b>VIE</b>	Visible implant elastometer (tags)
<b>WSCS</b>	World Sturgeon Conservation Society
<b>WSIV</b>	White sturgeon iridovirus

---

## ACKNOWLEDGEMENTS

The authors of this document gratefully acknowledge the important contributions of the many individuals who participated in the various meetings and workshops organized by FAO, WSCS and EIFAC on sturgeon hatchery management and practices in the preparation process of this *Sturgeon Hatchery Manual*.

We would like to express our gratitude to all specialists of the South Branch Federal Center of Selection and Genetics for Aquaculture, Ministry of Agriculture of the Russian Federation, especially Yu.N. Chmyr, L.R. Akhteryanova, V.I. Berezovskaya, Ya.G. Merkulov, E.A. Savelyeva and V.A. Timonina. We also would like to address special thanks to D.V. Ananyev, V.N. Krupsky, Ya.G. Merkulov and E.V. Stefanov for their valuable assistance in manuscript preparation. The authors would also like to thank P. Vecsei (Canada) for allowing them to use some of his illustrations of sturgeon species and the following experts for their valuable comments on the draft of this manual: P. Williot (France), D. Firzlaff (Germany), D. Memiş (Turkey), S. Ustaoglu (Turkey), A. Ozdemir (Turkey), O. Tufek (Turkey), D. Bartley (FAO) and M.R. Hasan (FAO). The authors further wish to acknowledge the contribution of S. Doroshov (United States of America) for his longstanding support and valuable assistance in editing parts of the draft manuscript, J.R. Arthur (FAO consultant) for the technical editing of the final version, and R. van Anrooy and C. Yavuz (FAO SEC) for their technical advice, coordination and formatting assistance during the production and publication process.

Financial support for the production of this manual in the English, Turkish and Russian languages was provided by the FAO Technical Cooperation Programme (TCP), FAO Subregional Office for Central Asia (SEC) and the Fisheries and Aquaculture Resources Use and Conservation Division (FIR) of the FAO.



## INTRODUCTION

An examination of the scientific literature shows that much effort has been directed towards developing the biological fundamentals of sturgeon hatchery stock enhancement. The advances in this field are undoubtedly due to the work of such prominent Russian scientists as N.L. Gerbilsky, I.A. Barannikova, T.A. Dettlaff, A.S. Ginsburg, B.N. Kazansky and I.I. Kozhin. The results obtained in these studies laid the foundation for the implementation of the large-scale sturgeon hatchery stock enhancement programmes that occurred in the Sea of Azov and the Caspian Sea during the 1960s and 1970s. To promote the performance of sturgeon hatcheries, manuals dedicated to the basic elements of hatchery technology for different sturgeon species have been published (e.g. Ginsburg, 1968; Mailyan, 1971; Anon., 1971; Kazansky and Molodtsov, 1974; Igumnova, 1975; Barannikova and Boev, 1977; Milshtein, 1982).

Artificial propagation has played an important role in sturgeon population enhancement in natural waterbodies, especially in the Sea of Azov, with the objectives of implementing the existing technology for the modification of sturgeon artificial reproduction, as well as the adaptation of hatchery stock enhancement methods to new environmental conditions. The manual *Guidelines on Artificial Reproduction of Sturgeons in the Caspian and Seas* (Anon., 1986), achieved this objective. Although the methods of sturgeon hatchery stock enhancement presented in the mentioned guidelines were based on the results of multidisciplinary research on various aspects of sturgeon biology, they were associated with the use of wild broodstock only that had been captured in the river basins of the Sea of Azov and the Caspian Sea. The dramatic decline of sturgeon populations in these seas, despite the prohibition of the commercial fishery for sturgeon beginning in the year 2000, led to the need for the rapid establishment of farmed sturgeon broodstocks. In addition, sturgeon hatcheries lacked updated manuals or handbooks covering the different phases of domestic sturgeon broodstock management.

The need to develop the present manual was also urgent in light of the extensive experimental trials conducted in Russia, the United States of America, Italy, France, Germany, Turkey and other countries during the last two decades, as well as the latest advances in commercial sturgeon farming and broodstock management, including those for anadromous species. As a result, noticeable improvements in existing sturgeon culture methods and procedures have been implemented (Doroshov *et al.*, 1983; Conte *et al.*, 1988; Parauka, 1993; Hochleitner and Gessner, 1999; Mohler, 2003; Williot *et al.*, 2007, 2009). It should be noted that despite the obvious success of sturgeon larvae and fry rearing biotechnology intended for commercial aquaculture (Gisbert and Williot, 2002b), not all of these achievements may be recommended for the rearing of Ponto-Caspian juveniles for restocking (Chebanov and Billard, 2001; Billard and Lecointre, 2002).

The key principles of two different approaches (aquaculture and restocking) have been considered in the Ramsar Declaration on Global Sturgeon Conservation



(2006). While the primary objective of sturgeon aquaculture has been to maximize the efficiency of production (highest growth and survival rates), the aim of sturgeon restocking is to improve fitness for survival in the wild. The latter requires unification of protocols and sturgeon hatchery management on the basis of sound standardized handling (minimizing the potential impacts of stressors), rearing, training and evaluation of fitness indices of larvae and fry, as well as optimization of the release of hatchery-produced juveniles into natural waters (Agh *et al.*, 2007). Moreover, the use of only captive broodstock for restocking of Ponto-Caspian sturgeons and the constantly controlled reproduction may negatively influence domestication (Bilio, 2007) if developing domestic broodstocks is not performed within the frameworks of genetically and environmentally sustainable programmes (Chebanov, 1998).

One of the limiting factors for the development of hatchery-reared broodstocks has been the lack of appropriate methods for early noninvasive sex identification (starting from the age of 1.5 years and weight of 1.5–2 kg) that would allow increased efficiency in the creation and use of sturgeon pedigrees and broodstock selection. The development of a new rapid noninvasive ultrasound technique for early sexing and gonad staging enables this problem to be resolved (Chebanov, Galich and Chmyr, 2004; Chebanov and Galich, 2008, 2009, 2010).

The ultrasound diagnostic method has been shown to be a highly informative and useful noninvasive rapid technique for sexing and maturity staging that can strongly assist in the optimization of management control of farmed broodstock. It is important to note that even today, this method may enable early (three to six years prior to maturity, depending on the species) selection of not only males intended for sale, but also of females (from each generation) destined for broodstock and caviar production. We should also note that owing to the implementation of the diagnostic methods described in this manual, one of the largest heterogeneous broodstocks of eight sturgeon species has been established (Chebanov and Billard, 2001). The mass maturation of farmed females of some sturgeon species (Azov beluga, stellate, ship, Russian and Persian sturgeons) reared using only artificial feeds and the obtaining of viable progeny from them, a first requisite for sturgeon culture, has been conducted annually since the year 2000.

The present manual incorporates the latest scientific advances and experiences gained in commercial sturgeon culture and existing better management practices (BMPs), as well as the information presented in the previous manuals included in the reference list. Previous authors have described the separate phases of sturgeon hatchery technology at different levels. The present manual focuses on the less known, previously unreported aspects of hatchery stock enhancement, especially those related to controlled sturgeon broodstock management, year-round reproduction, the ultrasound technique of early sexing and staging, and other original results of the authors' extensive experimental background.

## Chapter 1

### Azov-Black and Caspian seas sturgeon taxonomy, biology, distribution and life history

#### 1.1 INTRODUCTION

Sturgeons belong to Phylum Chordata (chordates), the Class Osteichthyes, Subclass Actinopterygii. Within the Subclass Actinopterygii, the Actinopteri, are the sister-group of the Cladostia (bichirs, Polypteridae). In the Actinopteri, the sturgeons and paddlefish (Chondrostei) are a sister-group of the Neopterygii (gars, bowfin and bony fish) (Billard and Lecointre, 2002). The Chondrostei include the Acipenseriformes, with the two monophyletic families, Polyodontidae and the Acipenseridae. The family Acipenseridae (Bemis, Findeis and Grande, 1997; Billard and Lecointre, 2002) contains four genera (*Huso*, *Acipenser*, *Scaphirhynchus* and *Pseudoscaphirhynchus*).

Sturgeons are the oldest of the freshwater fishes, having evolved some 200 to 250 million years ago. They are distinguished from modern bony fishes by a cartilaginous skeleton. The notochord is surrounded by a sheath (the perichord) that supports the cartilaginous structure (Hochleithner and Gessner, 1999). The spinal chord is located above the notochord. The caudal fin is typically heterocercal, with the continuation of the spinal cord into the upper body.

Sturgeons have an intestinal spiral valve that increases the surface available for nutrient intake and the time required for food digestion. The swimbladder is simple and physostomous, connecting with the gut. The body is covered by five rows bony dermal plates (scutes).

Of the 27 species of Acipenseriformes (see Annex I) that have spawned in a total of 85 rivers globally (Bemis and Kynard, 1997), seven species are native to the Black Sea Basin.

It is known that karyotypes of Acipenseriformes are unique as compared to other fishes (Birstein, Doukakis and DeSalle, 1999; Fontana *et al.*, 1999; Artyukhin, 2008; Vasil'eva, Kuga and Chebanov, 2010). Two groups can be distinguished: tetraploid species with approximate chromosome number of  $2n = 120$  and octoploid species, with the chromosome number close to  $4n = 240$ . Of the species inhabiting the Black Sea, the beluga, stellate sturgeon, sterlet, ship and Atlantic sturgeon belong to first group, while the Russian and Persian sturgeons belong to the second one.

Sturgeons are characterized by a high ability for hybridization. In sympatric populations in the wild, almost all species are known to have hybridized. However, the intraspecific or intergenetic crosses ( $2n \times 2n$  or  $4n \times 4n$ ) are fertile, while the interploid hybrids ( $2n \times 4n$ ) are triploid and are usually sterile (with a chromosome number of approximately 160 – 180). This is important, because the wide use of hybrids in sturgeon farming can led to escapes into the wild and to genetic contamination of sturgeon populations in natural waterbodies.

## 1.2 BIOLOGY, DISTRIBUTION AND LIFE HISTORY

### 1.2.1 Beluga (giant sturgeon) – *Huso huso* Linnaeus, 1758

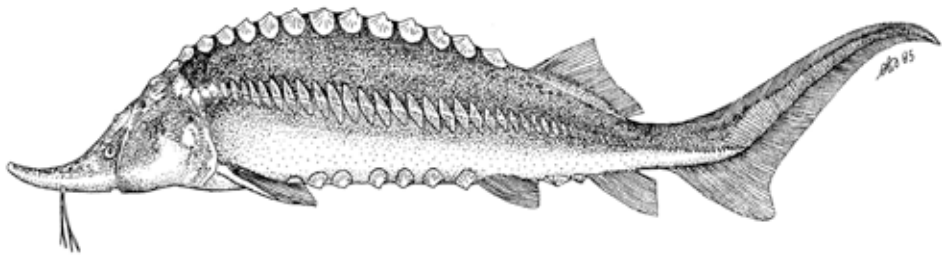
#### 1.2.1.1 Distribution

The beluga inhabits the Black, Azov, Caspian and Adriatic seas. Before the regulation of river flows, the natural spawning grounds of the beluga were located in the upper reaches (up to 3 000 km from the sea). The main spawning rivers in the Caspian Sea basin are as follows: Volga, Ural, Kura, Terek and Sula. The beluga ascended the Volga River up to the higher courses and was recorded in the Oka, Sheksna, Kama, Sura and other Volga tributaries. In the Azov basin, it entered the Kuban River up to and above the Ladozhskaya settlement, while in the Don River, it ascended to the Voronezhskaya region (Reshetnikov, 2002). Spawning of beluga in the Black Sea basin was in the large rivers: the Danube (more than 2 000 km from the mouth), the Dnieper, the Southern Bug, the Dniester and the Rioni. The duration of the spring spawning migration ranged from 50 to 80 days (d).

#### 1.2.1.2 Morphological overview

The beluga is one of the largest sturgeon species and has a solid and thick body (Figure 1).

**Figure 1:** Caspian-stock adult beluga (illustration by M. DAntoni, FAO Original Scientific Illustrations Archive).



The snout is short and blunt. The mouth is large and has a crescent shape; the lower lip is interrupted at its center. The barbels are flat, with leaf-like appendages that reach almost to the mouth. The gill membranes are adnate and form a fold.

The mean length and weight of beluga females and males in commercial catches (recorded in the 1970s) were 267 and 221 cm and 142 and 81 kg, respectively, while the maximum values were 4.6 m and in excess of 2 000 kg. In the Sea of Azov, the largest recorded length was 4.6 m and the largest weight was 750 kg. The meristic characters of beluga are presented in Table 1.

**Table 1:** Summary of the meristic characters of different Ponto-Caspian sturgeon species (according to CITES Identification Guide – Sturgeon and Paddlefish, 2001). Key: DF – dorsal fin rays; AF – anal fin rays; DS – dorsal scutes; LS – lateral scutes; VS – ventral scutes; GR – gill rakers; poD – plates between dorsal and caudal fins; poA – plates between anal and caudal fins; prA – plates between anus and anal fin; AL – average length (cm); ML – maximum length (cm).

Species	DF	AF	DS	LS	VS	GR	poD	poA	prA	AL	ML
<i>Huso huso</i>	48–81	22–41	9–17	28–60	7–14	17–36	0	0	0–3	185–250	500
<i>A. gueldenstaedtii</i>	27–51	16–35	5–19	21–50	6–14	15–36	0–2	1–2	1–3	100–150	200
<i>A. persicus</i>	27–51	16–35	7–19	23–50	7–13	15–31	0–2	1–2	1–2	130–200	
<i>A. stellatus</i>	40–54	22–35	9–16	26–43	9–14	24–29	0	0	1–5	128–150	220
<i>A. sturio</i>	30–50	22–33	9–16	24–40	8–15	15–29	3–9	3–5	2–6	130–220	300+
<i>A. nudiventris</i>	39–57	17–37	11–26	33–74	11–17	24–45	0	0	0–3	120–170	200+
<i>A. ruthenus</i>	32–49	16–34	11–18	56–71	10–20	11–27	0	0	1–4	30–60	100

The dorsal surface of the Azov Sea subspecies of beluga is light grey in color, while that of the Black Sea subspecies is darker. The ventral side is white.

### 1.2.1.3 Life history

The beluga lives up to 100 years. It reaches puberty later than other species, the male at 12–14 years, the female at 16–18 years. The generation interval is 4–5 years. The Azov population of beluga tends to mature earlier than other intraspecific groups (males at 10–12 years, females at 14–16 years) and has higher growth rates (Figure 2).

This species has two ecological races: the hiemal race, which migrates from October to November, and the vernal race, which migrates from March to April. The latter can spawn from April to May during the spring flood climax when water temperatures are from 6 to 12 °C. The beluga lays eggs at deep locations (depths of 4–15 m) with high flow rate and a stone and gravel substrate. The fecundity of females is size dependent and ranges from 200 000 to 8 million eggs. The eggs are large; for example, the eggs of the Volga beluga range in diameter from 3.6 to 4.3 mm and weigh from 26 to 36 mg. The mean duration of embryonic development is 200 hours (h) at a water temperature of 11–12 °C.

The primary feed items of beluga fry of 3–5 g weight are molluscs, crustaceans and worms (mysids, gammarids, oligochaetes, polychaetes, etc.). The adult beluga is a pelagic predator. The preferred prey of Caspian beluga are roach (*Rutilus rutilus*), pike-perch (*Stizostedion lucioperca*), common carp (*Cyprinus carpio carpio*), freshwater bream (*Abramis brama*), European anchovy (*Engraulis encrasicolus*) and other species, as well as sturgeon fry. In the Black Sea, beluga prefers anchovy and goby (*Gobiidae*) (Zheltchenkova, 1964).

**Figure 2:** Azov-stock adult beluga from farmed broodstock of the South Branch Federal Center of Selection and Genetics for Aquaculture, Krasnodar, Russia.



### 1.2.2 Russian sturgeon – *Acipenser gueldenstaedtii* Brandt & Ratzeburg, 1833

#### 1.2.2.1 Distribution

The Russian sturgeon is one of the most widely distributed representatives of the genus of *Acipenser* – it inhabits the basins of the Black and Caspian seas and the Sea of Azov, with separate local stocks occurring in the large rivers entering these seas (Figure 3). The primary spawning river is the Volga and its tributaries: the Sheksna, Oka, Vetluga, Kama and Vishera rivers. It previously ascended the Ural River to Orenburg. It also enters in limited numbers from the Caspian Sea to the Terek, Sulak and Samur rivers. From the Black Sea, the sturgeon migrates into the Danube and Dnieper rivers, moving in insignificant numbers into the Rioni, Mzymta, Psow and other rivers. It goes up the Dnieper to Mogilev and rarely to Dorogobuzh. In the past, it entered into Turkish waters, especially the western Black Sea coastal areas such as the Sakarya, Yesilirmak and Kizilirmak (Devedjian, 1926; Edwards and Doroshov, 1989; Ustaoglu and Okumus, 2004; Memiş, 2007).

**Figure 3:** Azov-stock adult Russian sturgeon (illustration by M. D'Antoni, FAO Original Scientific Illustrations Archive).



To spawn, it leaves the Sea of Azov for the Don River (to Zadonsk) and for the Kuban (upstream of the mouth of the Laba River), visiting many tributaries of these large rivers for 300 km from the mouth.

### 1.2.2.2 Morphological overview

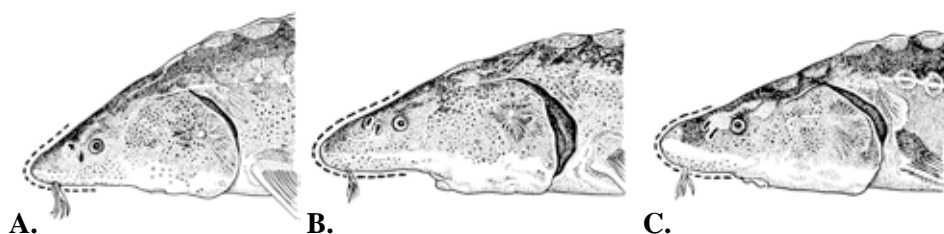
It should be noted that, in the opinion of Marti (1940), the Sea of Azov and the western Black Sea populations of the Russian sturgeon represent separate subspecies (e.g. *A. g. tanaicus* and *A. g. danubicus*, respectively). In terms of its genetic and morphometric characteristics, the Black Sea population of Russian sturgeon holds the position between the Azov and Caspian populations (Table 2). The main molecular and genetic trait of the Azov and Black Sea population as distinct from the Caspian one is the presence of a baerii-like mitotype in the latter. Note that specimens of Caspian origin can be encountered in the Azov population, due to introduction of fertilized eggs from the Caspian basin during the 1960s and 1970s (Chebanov et al., 2002; Timoshkina *et al.*, 2009).

**Table 2:** Matrix of standard distances  $F_{ST}$  between populations of Russian sturgeon (Timoshkina, 2009).

	Caspian Sea	Sea of Azov	Black Sea
Caspian Sea	–	0.070	0.058
Azov Sea	0.00024	–	0.043
Black Sea	0.00293	0.06641	–

Many investigators have clearly shown that Black Sea and Azov Russian sturgeon specimens differ significantly from the Caspian basin Russian sturgeon by a majority of the systematically important morphological and meristic characters (Table 3), and that they are rather close to the Persian sturgeon (*A. persicus*) (Figures 4 and 5).

**Figure 4:** **A** – Caspian-stock adult Russian sturgeon; **B** – Persian sturgeon; **C** – Azov-stock adult Russian sturgeon (illustration by M. D'Antoni, FAO Original Scientific Illustrations Archive).



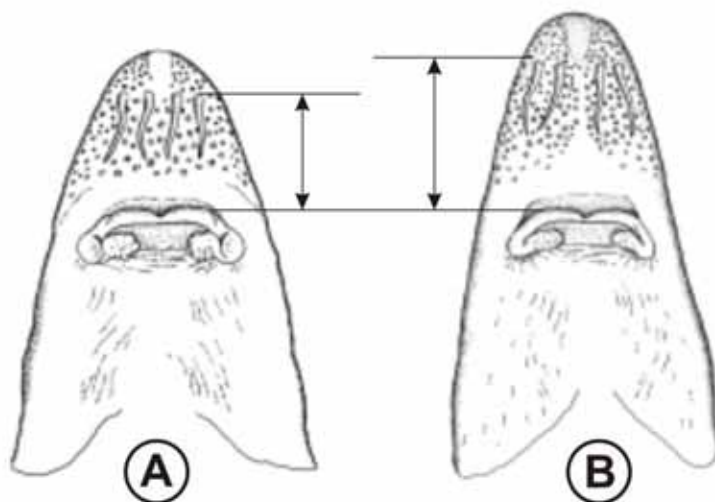
**Table 3:** Comparison of Russian sturgeon populations in terms of morphometrical indices (modified from Timoshkina, 2009). Key: DF – dorsal fin rays; AF – anal fin rays; DS – dorsal scutes; LS – lateral scutes; VS – ventral scutes; GR – gill rakers; AL – average length (cm); C – head length (cm).

Índeks		Population		
		Caspian Sea	Sea of Azov	Black Sea
DF	mean	41.0	35.7	<b>36.3<sup>1</sup></b>
	range	33–51	27–41	<b>30–43</b>
AF	mean	25.8	21.9	<b>23.9</b>
	range	21–35	16–25	<b>20–28</b>
GR	mean	23.5	21.5	<b>21.8</b>
	range	19–36	15–26	<b>17–27</b>
DS	mean	12.1	<b>11.9</b>	12,0
	range	9–19	5–15	9–15
LS	mean	39.0	30.5	<b>34.2</b>
	range	30–50	21–36	27–38
VS	mean	9.8	9.6	9.6
	range	7–14	6–11	7–12
Ratio head length to absolute body length (C/AL), %		18.1	16.4	17.5

<sup>1</sup> Characters that have intermediate values from comparison of the three populations are indicated by bold type. The values of indices of Caspian and Black seas populations are given according to Berg (1948) and Podushka (2003).



**Figure 5:** Base of barbels close to mouth: **A** – Russian sturgeon; **B** – Persian sturgeon (illustration by M. D'Antoni, FAO Original Scientific Illustrations Archive).



Differences exist in: the number of scutes in the main rows (DS, LS, VS), the number of rays in unpaired fins (DF, AF) and the number of gill rakers on the first branchial arch (GR). In addition, there are significant differences in immunochemical parameters (antigen composition of the serum proteins) and in behavioural characteristics between these groups: i.e. in the periods of anadromous migration, spawning temperatures and in the reaction of prelarvae to light (positive and negative phototactic response, respectively, in Caspian and Black (and Azov) seas individuals). Also there are morphological differences in the form of the head and the colour of the body (Podushka, 2003).

The body of the Russian sturgeon is of elongated, spindle-shaped form. The snout is short and obtuse. The barbels are closer to the end of the snout than to the mouth. The lower lip is interrupted. The body is covered with the stellular plates between the rows of scutes; sometimes the small bony plates are scattered between the scutes. The colour varies widely; usually the dorsal surface is greyish-black, the sides of body are of dusty colour and the belly is white.

### ***1.2.2.3 Life history***

Typical of the Russian sturgeon is a complex intraspecies structure: it has winter (hiemal) and spring (vernal) forms, and within each are smaller groups differing in the periods of entering the rivers, sizes of fish, duration of stay in the freshwater spawning site, time of spawning, etc. Males obtain sexual maturity at the age of 11–13 years, while females become mature at 12–16 years. In the Sea of Azov, they usually mature two years earlier than other populations. The weight of the mature Volga sturgeon female averages 22–24 kg, while in the Sea of Azov it is 15–18 kg (Figure 6). The maximum size recorded for the Black Sea is 236 cm



in length and 115 kg in weight, while in the Caspian Sea they are 215 cm and 105 kg, respectively (Vlasenko et al., 1989). The life span may reach 50 years (Tsepkin and Sokolov, 1970).

**Figure 6:** Russian sturgeon from farmed broodstock of South Branch Federal Center of Selection and Genetics for Aquaculture, Krasnodar, Russia.



The spawning migration of sturgeon extends from late March – early April until November. The peak of the spawning run in the Volga River occurs during the summer months (with its maximum in July), while in the rivers of the Azov basin, it happens during spring and autumn, the fish of the later run overwintering in the rivers.

The spawning of the spring sturgeon in the Caspian basin takes place in the middle of May to early June, when the water temperature is 8–14 °C. In the Azov basin, it occurs from late April until the end of May at a temperature of 16–18 °C. The spawning areas are located on sites with gravel or stony bottom, at a depth of 4 to 25 m, and with a flow rate of 1.0–1.5 m/s.

The fecundity of the Russian sturgeon varies from 50 000 to 1 165 000 eggs. At 18 °C, the development lasts about 100 hours (h). The prelarvae, ranging in length from 10.5 to 12 mm, are swept away from the spawning areas by the current and swim freely up and down throughout the water column. When they are a slightly more than 20 mm long, the sturgeon prelarvae turn to exogenous feeding, at first feeding on plankton and later on small benthic organisms. After spawning is completed, the adult fish do not remain very long in the rivers but migrate rapidly back to the sea. At sea, the adult sturgeons feed mainly on mollusc beds at depths ranging from 2 to 100 m. The fry feed at depths of from 2 to 5 m. In addition to molluscs, the Russian sturgeon also feeds on small fish: in the Black Sea – on bullheads, anchovy and sprat; in the Caspian Sea – on bullheads and sprat (Zheltenkova, 1964).

### 1.2.3 Persian sturgeon – *Acipenser persicus* Borodin, 1897

#### 1.2.3.1 Distribution

*Acipenser persicus* was described by Borodin (1897) as a separate species from the Ural River sturgeon (Figure 7), but later Berg (1948) considered it a subspecies of the Russian sturgeon, *A. gueldenstaedtii persicus* (Borodin) with a primary area of natural habitat in the Kura and Sefidrud rivers. In the Volga and Ural rivers, the Persian sturgeon was considered for a long time as one of the intraspecific

forms of the Russian sturgeon (*A. gueldenstaedtii*) – the so called “late spring or summer-spawning sturgeon” (Barannikova, 1975), but further morphological, physiological and biochemical studies (Artyukhin, 2008) lead to the restoration of its status as a distinct species.

**Figure 7:** Caspian-stock adult Persian sturgeon (illustration by M. D'Antoni, FAO Original Scientific Illustrations Archive).



Thus, taking into consideration recent taxonomic studies, the Persian sturgeon comprises two subspecies: *A. persicus persicus* Borodin, 1897, occurring in the Caspian Sea, and *A. persicus colchicus* Marti, 1940, occurring in the eastern part of the Black Sea (Reshetnikov, 2002).

#### ***1.2.3.2 Morphological overview***

In appearance, the Persian sturgeon looks like the Russian sturgeon. It differs from the latter by possessing a more extended, massive and downward curving snout, an elongated, bulky and dorsal-ventrally compressed body, and a lighter colour (Figure 8). The dorsal surface is ash-grey or horizon blue in colour with the tint of blue or steel around the sides; the belly is yellowish-white. It has an inferior and protractile mouth; the upper lip is indented in the middle and the lower lip is interrupted. The barbels are closer to the end of the snout than to the mouth (Artyukhin, 2008).

**Figure 8:** Adult Persian sturgeon from farmed broodstock of the South Branch Federal Center of Selection and Genetics for Aquaculture, Krasnodar, Russia.



### **1.2.3.3 Life history**

The Persian sturgeon prefers warmer waters than the beluga and Russian sturgeons. In the basin of the Caspian Sea, it is drawn mainly towards its southern and middle (the Kura, Sefidrud, Terek, Samur and Sulak rivers). It is a rarer visitor to the northern Caspian rivers (the Volga and Ural). In the Black Sea, it inhabits the northern areas, ascending mainly the rivers of the Caucasus (the Rioni, Inguri, Mzymta and Psow rivers) and possibly, the Kizilirmak and Yesilirmak rivers of Turkey (Devedijan, 1926). In contrast to the Russian sturgeon, the Persian sturgeon spawns in swift-flowing mountain rivers and does not ascend very far.

The Persian sturgeon is larger than the Russian sturgeon. The body weight of the Persian sturgeon from the Volga River averages 19 kg for males and 27.8 kg for females, whereas for the Russian sturgeon they average 11 and 18.8 kg, respectively (Artyukhin, 2008). The Persian sturgeon features a higher rate of linear and weight growth as compared with the Russian sturgeon, possibly due to the higher temperatures of the areas inhabited. Thus the average length of a 15-year-old Persian sturgeon female is 132 cm, that of the male, 122 cm, while for the Russian sturgeon, it is 123 cm and 113 cm, respectively.

The maximum age of the Persian sturgeon from the Kura is 48 years. In the past, its maximum size in the Caspian Sea reached 242 cm; however, at present they do not exceed 205–230 cm. In the Volga, 38-year-old individuals are encountered. In the Kura, it attains maturity at 8 years (males) and at 12 years (females). In the Volga and the Ural rivers, it matures later: the males at 15, the females at 18 years. A distinctive ecological characteristic of the Persian sturgeon is summer spawning. Thus, in the Volga River, it spawns in the same areas as the other anadromous sturgeons do, but later and at the higher water temperatures of June through August of 16 to 22 °C or more often, at 20–22 °C. In the southern Caspian rivers, the Persian sturgeon spawns at water temperatures of 15–25 °C. In the Rioni River, its spawning was observed in July at a water temperature of 17 to 23.6 °C (Ninua, 1976). Like the Russian sturgeon, it has groups of spawners differing in the periods of entering the rivers (winter and spring groups).

Fecundity varies from 85 000 to 840 000 eggs, depending on the female's size. A mature egg measures 3.2–3.8 mm in diameter. The hatched larvae do not stay too long in a river, but migrate down to the sea, where they fatten intensively. In the Caspian Sea, the primary places of feeding migration are in the southern part. Shellfish and crabs are prevalent in the diet of the adults, while juveniles in the river estuaries consume gammarids, oligochaetes, mysids, clams, worms and pelagic fish.

## **1.2.4 Stellate sturgeon – *Acipenser stellatus* Pallas, 1771**

### **1.2.4.1 Distribution**

This diadromous species inhabits the Caspian, Black and Azov seas and was found rarely in the

Adriatic Sea (Figure 9). The Volga, Ural, Terek, Sulak, Kura, Danube, Don and Kuban rivers are the major spawning rivers. The length of the spawning migration route in the Volga River is up to the cascade of dams at Rybinsk; in the Ural, it ascends to Uralsk; in the Don – to Pavlovsk; in the Kuban – to Armavir; in the Middle and Upper Danube – as far as Bratislava and even Strasbourg; in the Dneestr – up to the mouth of the Zbruch River. It also entered the South Bug, the Dnepr and the Desna for spawning. The highest natural abundance and biomass of stellate sturgeon remain in the Caspian Sea.

**Figure 9:** Caspian-stock adult stellate sturgeon (illustration by M. DAntoni, FAO Original Scientific Illustrations Archive).



#### 1.2.4.2 Morphological overview

As distinct from the Caspian subspecies, the Azov stellate sturgeon has a shorter head and snout, or more precisely, lower length of the head and snout (Figure 10) and at the same time, a wider snout at the base of the front pair of barbels. In addition, Azov subspecies exhibit earlier puberty and higher growth rate (Makarov, 1970).

**Figure 10:** **A** – Azov-stock stellate sturgeon; **B** – Caspian-stock stellate sturgeon; **C** – Danube-stock stellate sturgeon (After: “P. Vecsei - CITES Identification Guide – Sturgeon and Paddlefish, 2001”).



The snout is very long, flattened and bent upwards towards the tip. This character distinguishes the stellate sturgeon from all other species of the genus *Acipenser*. The body is elongated and spindle shaped. The mouth opening is transverse. The lower lip is not continuous and is interrupted at its center. The barbels are short, not fimbriated and not reaching the mouth, but are positioned closer to the mouth than to the top of the snout. It has five rows of scutes. The body is covered by small grains and bony stellate plates between the main scute rows. It has a blackish- brown or greyish dorsal surface and lighter flanks. The belly is white, and the ventral scutes are a dirty white color. Specimens from the sea may be darker than those from the rivers (Figure 11).

**Figure 11:** Azov-stock stellate sturgeon from farmed broodstock of the South Branch Federal Center of Selection and Genetics for Aquaculture, Krasnodar, Russia.



#### ***1.2.4.3 Life history***

Two different ecological forms of stellate sturgeon were reported in the Caspian Sea regions (Borzenko, 1942) as:

- i. the North Caspian Sea form *A. stellatus*, which is a typical form of this species, and
- ii. the South Caspian Sea form, *A. stellatus cyrensis*.

Immunological studies show that the northern and southern Caspian Sea stellate sturgeons are genetically distinct from each other and have distinct spawning run periods in the spring and winter.

The stellate sturgeon has hiemal (autumn spawning run), vernal (spring spawning run) and late vernal (summer spawning run) spawning run races. The total length of spring-summer migration is 120–130 days (d). In the wild, spawning occurs from April to September. The stellate sturgeon reaches sexual maturity sooner than other acipenserids, and the Azov population of this species is the earliest to mature. Generally, females require two, three or sometimes five years more than males to mature (Derzhavin, 1922; Borzenko, 1942; Chugunov and Chugunova, 1964). Stellate sturgeon reaches sexual maturity at 5–6 years (males) and 8–10 years (females). The Kuban stellate sturgeon reaches maturity 1–2, 2–4 and 4–5 years earlier than the Don (Makarov, 1970), Kura and Volga stellate sturgeon, respectively. This species reproduces on grounds with hard gravel or sand-gravel substrate at flow velocity ranging from 0.5–1.3 m/s and at 0.5–3.5 m depth, i.e. on spawning grounds that are located 240–470 km from the river mouth (lower than those of beluga and Russian sturgeons).

During the 1930s, the main food for this species was crustaceans and fish. However, in the following years, its diet changed considerably; the importance of fish decreased while that of worms and molluscs increased, such that the main food items for stellate sturgeon at present are crustaceans and worms. In rivers, juveniles feed on benthic and benthonectonic organisms when they switch over to exogenous feeding. These include gammarids, chironomid larvae, mysids and oligochaetes. It should be noted that the main food for juveniles varies in different rivers. Planktonic organisms play a role in their feeding only during early larval development (Zheltenkova, 1964).

Since the 1970s, reproduction of stellate sturgeon in the Azov basin has been performed only via hatchery stock enhancement. The production volume has decreased considerably due to the lack of wild breeders. The last mass release of stellate sturgeon juveniles in the Sea of Azov was in 2007 when over 100 000 individuals of average weight 2–2.5 g were stocked. In 2009, 14 000 juveniles weighing 700–800 grammes (g) were released in the Kuban River by the South Branch Federal Center of Selection and Genetics for Aquaculture. A few attempts to introduce Caspian stellate sturgeon fertilized eggs to sturgeon hatcheries were tried starting from 1960; however, these proved to be ineffective and were terminated (Chebanov *et al.*, 2002).

### 1.2.5 Atlantic sturgeon – *Acipenser sturio* Linnaeus, 1758

#### 1.2.5.1 Distribution

The Atlantic sturgeon is an almost extinct species that previously inhabited Europe, in the basins of the Baltic, North, Black and Mediterranean seas. In the Black Sea, it was most abundant in the eastern and southeastern parts (Figure 12).

**Figure 12:** Atlantic sturgeon (illustration by M. D'Antoni, FAO Original Scientific Illustrations Archive).



The spawning sites were located on the upper reaches of the rivers at distances of 500 to 1 000 km from the mouths (with the exception of the Rioni River, where spawning took place 130 km upstream): up the Neman River to Druskenik; up the Vistula to Krakow, into the San to Peremyshl; up the Oder River above Breslav; up the Elbe River to Vltava, up the Weser to the confluence of the Werra and the Fulda, and up the Rhine to Basel. The Atlantic sturgeon was present in the Po River and its tributaries and some other small Italian rivers flowing into the Adriatic and Tyrrhenian seas. It entered for spawning from the Gulf of Finland to the Neva River; and from Ladoga Lake to the Svir, Syas and



Volkhov rivers. In the Black Sea basin, the Atlantic sturgeon ascended into the Danube, Kuban, Rioni and Inguri/Dzhvari rivers; and to rivers of the Anatolian coast of Turkey, the Kizyl-Irmak and Eshil-Irmak (Devedijan, 1926; Edwards and Doroshov, 1989). It was reported off the coasts of Romania, Bulgaria and Ukraine in small quantities. As is mentioned in Rosenthal *et al.* (2008), due to hybridization with *A. oxyrinchus*, since the 12<sup>th</sup> century the range of *A. sturio* has excluded the Baltic Sea basin.

#### ***1.2.5.2 Morphological overview***

The Atlantic sturgeon has an elongated body and a pointed snout that is raised upwards. The upper lip is indented in the middle, while the lower lip is interrupted. The barbels, which are not fringed, are equally distant from the end of the snout and the chondral fornix of the mouth. The pectorals have strong acanthas. The body is covered with several rows of slanting, rhombic, densely arranged scutes.

#### ***1.2.5.3 Life history***

The Atlantic sturgeon is the most euryhaline species of sturgeon (up to 35 ‰ salinity) and one of the largest in the family – it reaches a length of 3.5 metre (m) and a weight of over 300 kg. In the Black Sea, it grows faster from the third year of life than the Russian sturgeon (*A. gueldenstaedtii*), reaching a weight of 12–47 kg at an age of 9–18 years.

The males of the Black Sea population attain sexual maturity at an age of 7–9 years, the females – at the age of 8–14 years (Ninua, 1976). In the rivers of the Baltic Sea basin, a spawning took place in June–July, while in the Black Sea basin (Danube, Rioni), it occurred from May to early July. The fecundity was 0.2–5.7 million eggs. The spawning areas are sited on stony and gravel grounds with a high flow rate. The eggs are 2.63 mm in diameter.

The spawning temperatures range from 7.7 to 22 °C, with egg incubation taking from 12 to 3 d, at the extremes, respectively. The hatched larvae are 9.3–11 mm long. The resorption of the yolk sac lasts about two weeks, after which, upon reaching a length of 16–18 mm, the larvae begin exogenous feeding (Ninua, 1976). The diet of larvae in the river includes copepods, crustaceans and insect larvae; in the sea, fingerlings feed on Gammaridae.

The fingerlings stay in the river for not less than two months, and by the autumn migrate down to the premouth where they live for 2–4 years, after which they leave for the sea, where they form small schools in marine bays whose salinity is reduced by rivers. The migrations are performed in small groups or individually, assemblages being formed during the spawning run and on the wintering grounds. The adult fish feeds on benthic animals: worms, crustaceans and molluscs, as well as small fish like gerbils (Gerbilidae) and anchovies (Engraulidae). The feeding migration may run as long as 1 000 km.

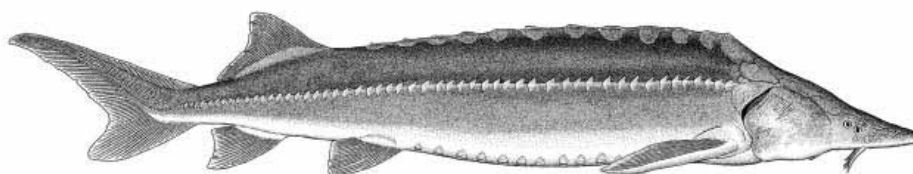
Currently, the largest spawning population of Atlantic sturgeon was noted in the Gironde River (Castelnaud *et al.*, 1991). In 1995, progeny was obtained from spawners caught in this river that led to the formation of broodstock that provided fertilized eggs in 2008 (Williot *et al.*, 2009). Other data available on the immature fish entering the Gironde River show that the entrance of the young sturgeon to freshwater is observed after the spawning migration from late June to late September. In October these fish return to the sea.

## 1.2.6 Ship sturgeon – *Acipenser nudiiventris* Lovetzky, 1928

### 1.2.6.1 Distribution

An anadromous fish, *A. nudiiventris* spends the largest part of its life in the coastal areas of the seas (to a depth of 50 m). It inhabits the Black, Azov, Aral and Caspian seas, as well as Balkhash Lake, where it was transported from the Aral Sea in 1933, and the rivers flowing into these waterbodies (Figure 13).

**Figure 13:** Ship sturgeon (illustration by M. D'Antoni, FAO Original Scientific Illustrations Archive).



In the basin of the Caspian Sea, the ship sturgeon was most widely represented in the Kura, Ural and Sefidrud rivers. In the basin of the Black Sea, it ascended for spawning to the Danube upstream of Budapest, being encountered in its tributaries. Individuals were also encountered in the Dnieper and Rioni rivers. In the basin of the Sea of Azov, the ship sturgeon was encountered in the Kuban River in the same places inhabited by the Russian sturgeon, and in the Laba River (tributary of the Kuban). Individuals were also noted in the Don River.

### 1.2.6.2 Morphological overview

The most important diagnostic feature of *A. nudiiventris* is the lower lip, which is continuous and not interrupted in the middle. The barbels are fimbriate. The first back scute is the largest.

The ship sturgeon attains a length of 2.0 m and more (Figure 14). The average weight of the spawner varies within the range of 17.7–21.9 kg (females and males). The gametosomatic index averages 18.4 percent.



**Figure 14:** Ship sturgeon from farmed broodstock of South Branch Federal Center of Selection and Genetics for Aquaculture, Krasnodar, Russia.



### ***1.2.6.3 Life history***

The ship sturgeon is predominantly a bottom fish, spending the largest part of its life in coastal areas of the sea (to a depth of 50 m); it prefers areas with silt-covered ground. Its residence in the river during spawning migration lasts from two to ten months. The ship sturgeon features, along with anadromous forms, “residential” populations that never leave the rivers (e.g. the population of the Kura River), similarly to the series of sturgeon species that occur in Siberian, Far-Eastern and North American rivers.

An ecological peculiarity inherent in populations of ship sturgeon but not recorded in other anadromous sturgeons is a strict attachment to mountain rivers having the availability of “holes”, and the presence of sand spits and a high concentration of suspended material in the water, particularly during periods of flooding.

Some ship sturgeon fry remain in the river until two to four years of age, while others migrate down to the sea during the first year of life (Reshetnikov, 2002). The periods of spawning migrations in the different rivers are not the same. Ship sturgeon migrate to the Kura during almost all the year, but as a whole, two peaks can be seen: a main peak in March–April and a less pronounced peak in October–November. The spawning run of ship sturgeon to the Ural River proceeds from early April to the middle of May.

In the basin of the Aral Sea, the winter spawning run race of ship sturgeon had retained the only type of spawning migration until an ecological catastrophe happened (Williot *et al.*, 2002). After the introduction of this species from the Aral Sea to Balkhash Lake and Ili River (before the catastrophe), ship sturgeon retain the winter (migration from the Lake occurs only in autumn).

The propagation of ship sturgeon in the Azov and Black sea basin occurs in May–June at the temperature of 12–17 °C on gravel bottom.

The ship sturgeon has the largest relative fecundity among the sturgeons, producing from 280 000–1 000 000 eggs. This high fecundity is related to the low survivability of the progeny, which inhabit the river for an extended period of time. The mature eggs are about 3 mm in diameter. The eggs are adhesive, sticking to the gravel in which their development takes place. The development of the eggs at a temperature of 17–19 °C takes 5 days (d) (Reshetnikov, 2002).

Some of the larvae hatching from the eggs migrate down to the sea, while others remain on the spawning areas for several months or even years. The 10-day-old larvae with resorbed yolk are 15.5–17.2 mm in length, while 30-day-old larvae are 24.6–37.2 mm long.

In the sea, the ship sturgeon feeds on a variety of benthic fish, predominantly gobies. Individuals remaining in the river feed mainly on crayfish and other shellfish; chironomids and sandhoppers are of less importance in their diet.

### **1.2.7 Sterlet – *Acipenser ruthenus* Linnaeus, 1758**

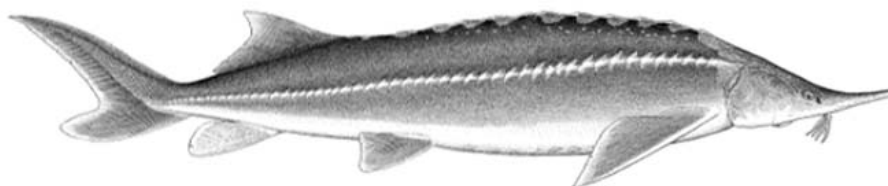
#### ***1.2.7.1 Distribution***

The sterlet inhabits the rivers of the basins of the Black, Caspian and Baltic seas. Its range also includes the rivers of the Northern Dvina, Ob and Yenisei. The most numerous populations occur in the Volga and Kama rivers. Previously, sterlet inhabited the Dnieper to Mogilev and its tributaries – the Pripyat, Desna and Teterev rivers. It also inhabited the Dnestr and was recorded in the Southern Bug and in the Dnieper Liman. At present, the sterlet is very rare in the Dnieper and the Southern Bug, but it still survives in the Dnestr upstream of the dam of the Dubossarskaya Hydroelectric Power Plant. In the Don, it was found in the middle and lower reaches, and in its tributaries – the Donets, Oskol, Medveditsa and Koper. It was frequently encountered in Taganrog Bay, while in the Kuban River, it was rare. Multiple populations of sterlet inhabit the lower reaches of the Danube down to the city of Vienna. Individuals were also noted in the mouth of the Rioni River (Reshetnikov, 2002).

#### ***1.2.7.2 Morphological overview***

The primary characters differentiating the sterlet from the majority of other species of the genus are the great number of lateral scutes (more than 50) and fimbriate barbels. It can be distinguished from the ship sturgeon (which also has more than 50 lateral scutes and fimbriate barbels) by an interrupted lower lip (Figure 15).

**Figure 15:** Danube-stock sterlet (illustration by M.DAntoni, FAO Original Scientific Illustrations Archive).



Sterlet is the smallest species in the family – the maximum length is 70–90 cm, while the weight is 2–4 kg (Figure 16). The life span is 20 or more years.

**Figure 16:** Kuban-stock sterlet from farmed broodstock of South Branch Federal Center of Selection and Genetics for Aquaculture, Krasnodar, Russia.



### *1.2.7.3 Life history*

In sterlet, the age at puberty, as well as the rate of growth is related to the climatic conditions of the habitat, and in the southern rivers begins at the age of 3–6 (more frequently 4–5) years in the males and 4–9 (more frequently 6–8) years in females.

The beginning of sterlet's spawning depends on water temperatures (7.5–10.0 °C), lasting up to temperatures of 15–16 °C. In the Volga and Kama rivers, spawning occurs from May until the beginning of June, coincidentally with the peak of high water.

The fecundity of the sterlet varies widely, ranging from 4 000 to 140 000 eggs. Spawning by young mature females takes place annually, while older females spawn biannually; however, the interspawning intervals may vary depending on the environmental conditions of the habitat. The eggs are adhesive and of 1.9–2 mm in diameter. The incubation period lasts 6–11 d. The yolk sac of the larvae resorbs in 6–10 d after hatching. At the age of 30 d, the fry are 3–4 cm in length, and the fingerlings in September measure 8–15 cm.

After spawning, sterlet leaves for the flooded marsh areas (small lakes), former river beds and the inshore areas of rivers, and as the flood waters recede, again enters the river beds. The adult sterlet feeds predominantly on larval chironomids, small shellfish and other invertebrates (gammarids, mysids). By midsummer the feed of the fry varies little from that of the adult.

In 1998, a programme of sterlet acclimatization in the Azov and Kuban basin started, through which about 10 million fry of this species reared from eggs produced from the broodstock of the South Branch Federal Center of Selection and Genetics for Aquaculture were released into Krasnodar Water Reservoir, as well as into the Kuban and Protoka rivers. In 2001, a sterlet female measuring 92 cm long, weighing 5.6 kg and having gonads at maturity stage IV was caught in the area close to the dam of Krasnodar Water Reservoir. It was also established that the males of sterlet mature in Krasnodar Water Reservoir at the age of two years, while females at four years of age show the highest rate of growth and early sexual maturation.

---

## Chapter 2

### Hatchery design

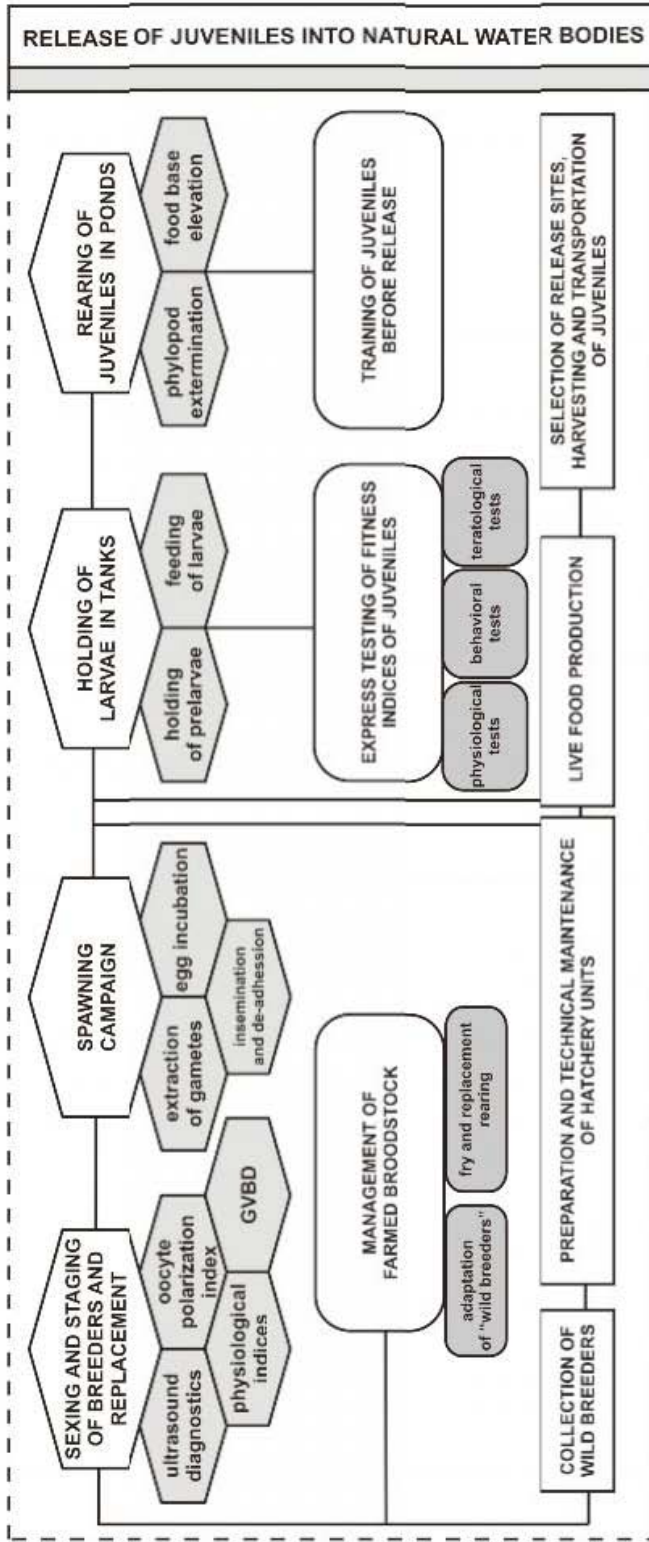
#### 2.1 BASIC REQUIREMENTS FOR HATCHERY DESIGN

At present, most existing sturgeon hatcheries in Russia, Azerbaijan, Iran, Kazakhstan and Ukraine have been constructed on the basis of traditional designs and are intended for the collection of a considerable quantity (several thousands) of wild breeders and simultaneous large-scale release (millions) of fingerlings of equal weight and age. Similar designs are aimed at narrow seasonal usage of production areas and do not involve such essential elements of modern hatchery biotechnology for artificial reproduction as the long-term prespawning holding of broodstocks at low temperature, live collection of gametes, adaptation (domestication) of wild breeders and immature fish, evaluation of fitness indices, training of fingerlings for survival in the wild, long-term release of different size-graded sturgeon juveniles, etc. (see Chapter 8–10).

When designing a hatchery, it is essential to consider the use of captive broodstock, including the need to control their reproductive cycles in order to prolong the period of spawning and the release of fingerlings into natural waters. The design of a sturgeon hatchery based on the technological scheme of hatchery operation comprises a range of basic and subsidiary biotechnological processes, as well as fry testing protocols (Figure 17). These include:

- collection of broodstock;
- transportation and unloading of broodstock;
- prespawning holding of broodstock, including long-term holding;
- hormonal stimulation of broodstock and production of gametes;
- egg fertilization and de-adhesion (unsticking);
- egg incubation;
- holding of prelarvae and grow out of larvae in tanks;
- rearing of fry in the grow-out ponds;
- discharge of pond water, counting of fingerlings, and their release to the wild; and
- culture of live food (*Daphnia*, *Artemia*, *Oligochaeta*).

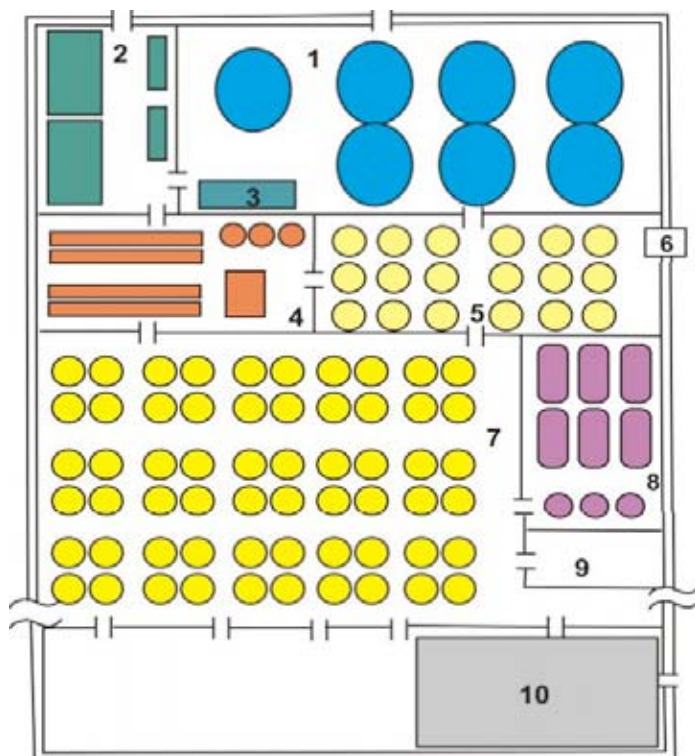
Figure 17: Layout of technological scheme of hatchery.



## 2.2 MODERNIZED HATCHERY SCHEMES

Currently, the sharp decline in the abundance of breeders in the wild is an important consideration in hatchery design (Figure 18). Therefore, some updated designs for sturgeon hatcheries have been suggested that aim at location in littoral areas, the adaptation of wild breeders to conditions of artificial holding, and the development and exploitation of domesticated broodstocks (Kokoza, 2004).

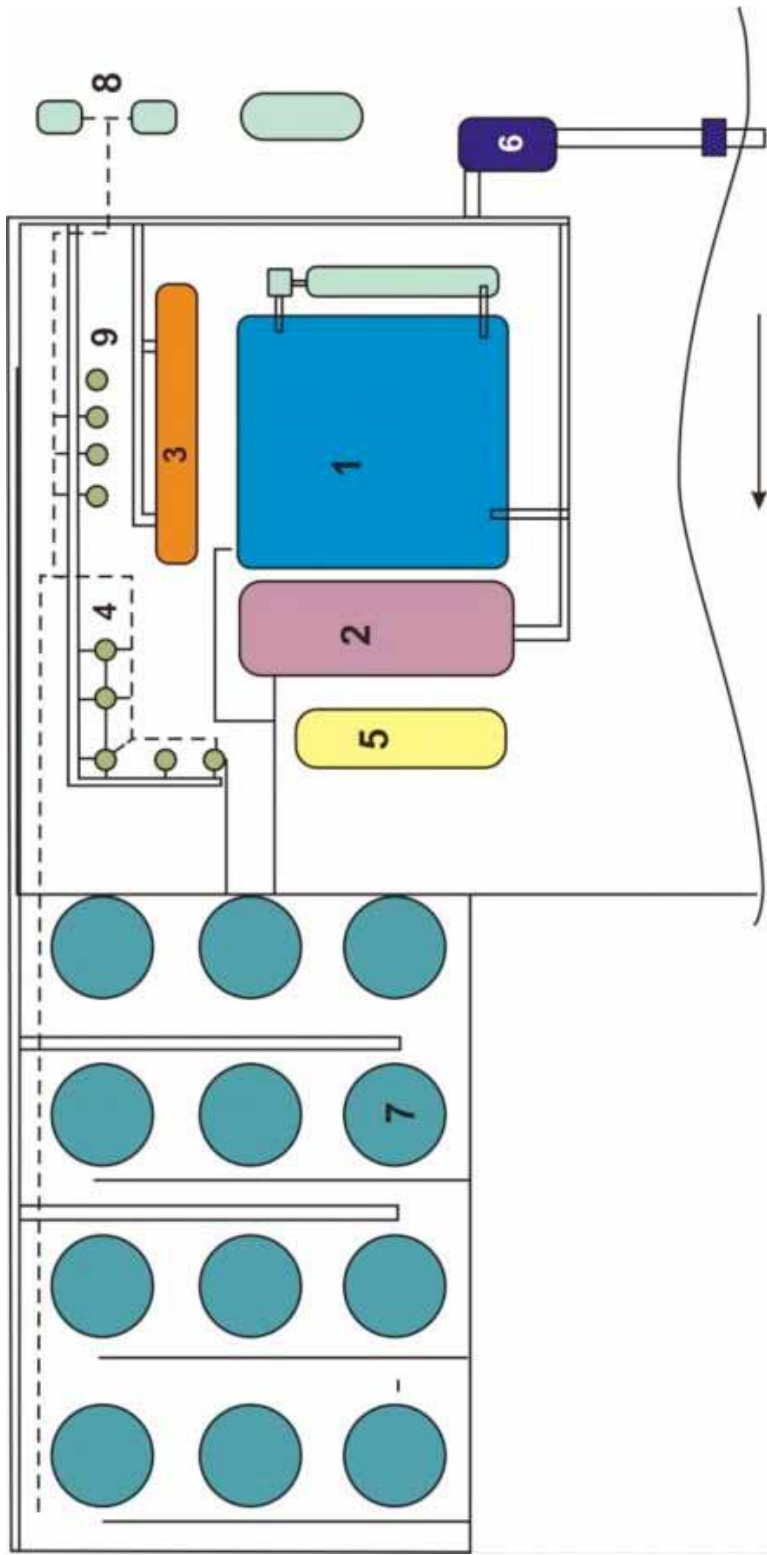
**Figure 18:** Layout of a purpose-built sturgeon hatchery (from Kokoza, 2004): 1 – unit for accumulation and long-term prespawning holding of broodstock with thermal regulation; 2 – tank unit (plot) for adaptation of collected broodstock and obtaining mature gametes from these broodstock; 3 – compact installations for regulation of water temperature in tanks; 4 – incubation unit with recirculating system of water treatment and controlled thermal regime; 5 – unit for transition of larvae to exogenous feeding; 6 – conditioner for indoor cooling and heating of the air and water in tanks; 7 – tank unit for standard sturgeon fry rearing with controlled water regime; 8 – unit for live food production; 9 – laboratory and production process supervision; 10 – water treatment unit.



As will be discussed in detail in Chapter 8, the efficiency of artificial propagation may be enhanced by shifting the season of gamete collection and rearing of larvae and fry. To accomplish this, sturgeon hatcheries should be equipped with special modules for thermal regime control (Figure 19).

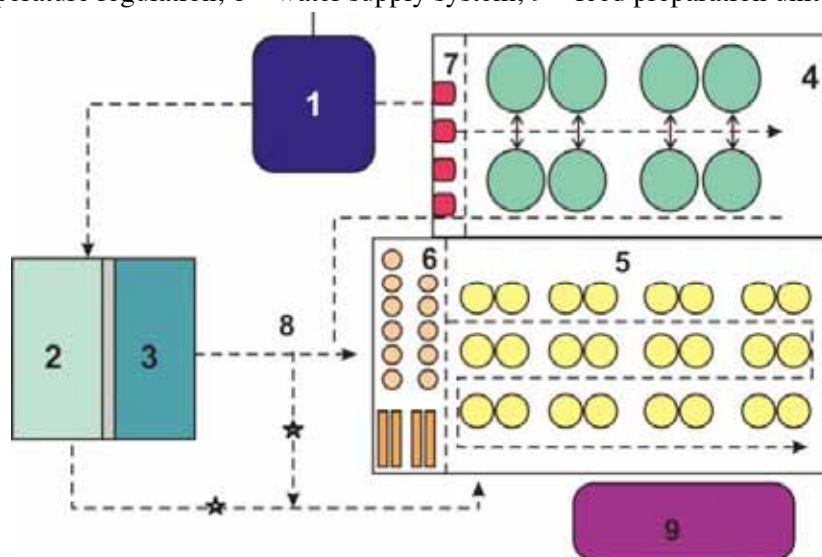


**Figure 19:** Example layout of fish hatchery of the multifunctional type: 1 – plastic tank (15–25 m<sup>3</sup>) equipped with a flow-through system and recirculated water supply; 2 – compact system for regulated thermal regime of water; 3 – incubation system of “Osetr” type; 4 – system for egg de-adhesion; 5 – water intake facilities with water treatment system; 6 – tank unit (1.5–2 m<sup>3</sup>); 7 – system of water aeration in tanks for transition of larvae to exogenous feeding.



Holding of the broodstock and rearing of fry in water with heightened salinity also allows for reproduction efficiency to be enhanced. To achieve this, the sturgeon hatchery may be located in a coastal area (Figure 20).

**Figure 20:** Layout of sea sturgeon hatchery of the coastal type (Kokoza, 2004): 1 – pump station; 2 – collector of freshwater; 3 – collector of seawater; 4 – unit for operations with broodstock with circulated water supply regime; 5 – tank unit for grow out of larvae and fry in freshwater, as well as rearing of fingerlings under conditions of increased salinity; 6 – unit for fertilized egg incubation and transition of larvae to exogenous feeding; 7 – compact equipment for water temperature regulation; 8 – water supply system; 9 – feed preparation unit.



### 2.3 SELECTION OF THE HATCHERY LOCATION

When choosing a suitable site for locating a hatchery unit, the following practical prerequisites should be considered:

- water source characteristics (sufficient water discharge, especially in low-water season (summer/winter));
- distance from the capture sites (preferably less than 25–30 km), to avoid long transportation of wild breeders;
- distance from the nearest settlements and the state of infrastructure (e.g. roads, canals);
- distance from an energy supply source (possible power lines routing, gas supply);
- distance from locations of fry release (preferably less than 15–18 km); and
- level of ground water (should not influence complete water discharge and drainage of pond beds) (Figure 21).



**Figure 21:** Don Sturgeon Hatchery (Azov Sea basin) (picture taken from Google Earth software application in 2010).



The area intended for the hatchery operation should be determined on the basis of the hatchery type and capacity. The latter is calculated based on the targeted volumes of fingerlings to be released. The temperature regime in the region and the specific environmental requirements of the sturgeon species to be reared should be taken into consideration and the feasibility of the polycyclic use of the production facilities evaluated (Figure 22).

**Figure 22:** Bertyulsky Sturgeon Hatchery (picture taken from Google Earth software application in 2010).

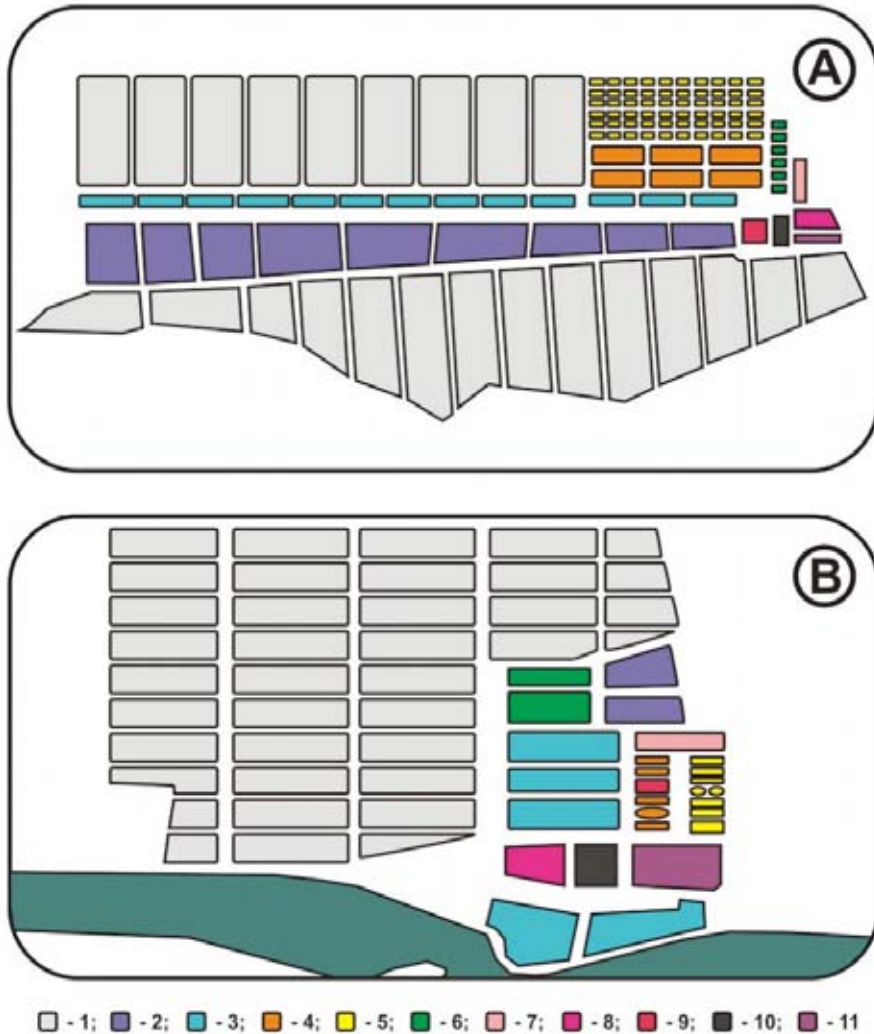


## 2.4 HATCHERY STRUCTURE

The design and construction of a sturgeon hatchery system should include the following obligatory units (Figure 23):

- prespawm holding unit, including long-term low temperature unit for holding of broodstock (LLTUHB) with water recirculation system;
- incubation unit for egg collection and incubation;
- tank unit (for grow out of larvae and fry in tanks and trays);
- live food production unit;
- laboratory, warehouse and subsidiary buildings (offices, etc);
- broodstock holding unit with feed preparation building;
- unit for adaptation of wild breeders to artificial holding conditions; and
- transportation unit.

**Figure 23:** Layout of sturgeon hatchery (Iran) (A – Shahid Rajaei; B – Shahid Marjany): 1 – ponds for fry rearing; 2 – broodstock holding facility; 3 – unit for senior replacement and wild breeders; 4 – tanks for *Daphnia* and *Artemia* culture; 5 – tank unit for prelarval holding and larval rearing; 6 – cages and tanks for prespawn holding of broodstock; 7 – incubation unit; 8 – unit for long-term holding of broodstock; 9 – oligochaete unit; 10 – administrative building; 11 – storage facilities, transportation unit.



During hatchery construction, appropriate water treatment systems (sedimentation tank, sand-gravel filtration systems) must be considered for water purification (removal of silt and prevention of entry of wild fish and invasive stages of fish parasites). Water for use in incubation and tank units should be provided only through a sedimentation pond, while water destined to production units should be supplied by pumps through sedimentation and net-screen systems.

The area, layout and depth of the ponds are determined in compliance with hatchery standards. The layout of the bed and collectors should ensure rapid (1–2 d) filling and draining of the ponds.

#### **2.4.1 Unit for prespaw holding of broodstock**

Flow-through ponds simulating the environmental conditions of natural spawning grounds (e.g. substrate, flow velocity) should be integrated into the design for prespaw holding of broodstock. There exist two common types of water reservoir intended for prespaw holding, the design of “Kazansky” and the “Kurinsky” type.

##### ***2.4.1.1 Holding facility of “Kazansky” type***

This facility consists of an earthen-pond system for long-term holding of broodstock along with an adjacent system of concrete tanks that are used for the short-term holding of fish after hormonal stimulation. An earthen pond has a length of 130 m and comprises two parts, an extended main part (100 m) of 2.5 m depth and a narrow (30 m) shallower (0.5–1 m deep) part that simulate conditions of sturgeon passage to the spawning reach of a river (i.e. high current velocity, gravel bottom) (Milshtein, 1982). Females and males are kept separately in ponds. The pond destined for males should be of shorter length (120 m) and should not have any narrowed part. The water demand in the ponds is established at the onset of the holding period and amounts to 30–40 liter/s; at the end of prespaw holding, it can be elevated to 300 liter/s.

##### ***2.4.1.2 “Kurinsky” type pond facility***

This type of facility consists of an earthen pond of 100 x 12 m that is divided into three sections by concrete baffles with openings. The bottom of all sections is covered by gravel, while the slopes are cobbled. The transported wild-caught females and males are loaded to the first section, which has a length of 60 m and a depth of 2.5 m. The normal stocking rate of broodstock for this section is 50–70 animals. At the onset of the spawning temperatures, females are transferred to the second section, which has a length of 30 m and a depth of 1–1.5 m. The third section (length of 10 m, depth of up to 1 m) is used for posthormonal stimulation holding of fish. This section is equipped with a double water supply system (pipeline and flute) and stand-alone drainage of water. The full cycle of water exchange takes 15 min with constant water demand of 30–40 liter/s. Typically, the third section is covered by a shed.

The updated design of the “Kurinsky cage” (pond) is a complex of the above-mentioned ponds and three concrete oval tanks adjacent to the narrow part of the pond (Figure 24).

**Figure 24:** Pond facility of the “Kurinsky” type.



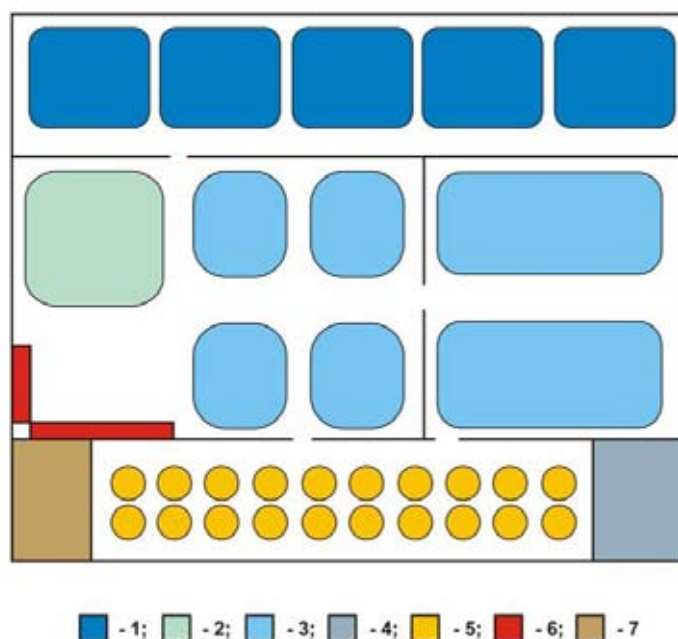
The middle tank is intended for holding of the necessary quantity of broodstock for the 2–3 d period prior to hormonal stimulation, while two other tanks are used for the separate holding of females and males after hormonal injections. The water supply and drain system in the tanks are provided separately for each tank.

#### **2.4.2 Broodstock long-term holding unit**

The long-term low temperature unit for holding of broodstock (LLTUHB) allows working with broodstock in a consistent manner, with water temperature regulation, enabling repeated cycles of fry rearing at the same areas during one season.

The LLTUHB is a one-story building that houses three main units: a tank unit(s) for holding of broodstock, a machinery unit and the control room. Tanks for broodstock holding should be made of reinforced concrete, have a circle or rectangle shape with rounded edges, have a surface area of 30–50 m<sup>2</sup> and a depth of 2 m. The inner surface of the tanks is tiled or covered by a firm waterproof material. In the machinery hall, refrigeration systems, recirculation pumps, filters, oxygenators and other equipment should be installed. In the control room, the control and laboratory equipment should be set up (Figure 25).

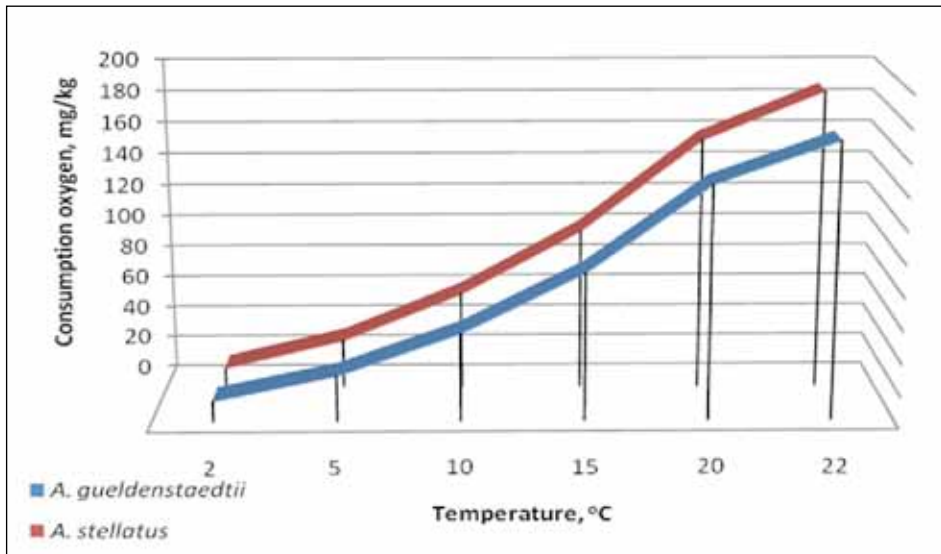
**Figure 25:** Layout of a unit with thermoregulation of water treatment: 1 – natural water tank; 2 – prespawning tank; 3 – chill tank; 4 – aeration blower; 5 – fry rearing tank; 6 – spawning and incubation area; 7 – mechanical space and thermoregulator.



It is recommended to perform the initial filling and supply of the tanks using groundwater, the temperature of which is lower than that of the waterbodies. It is a good practice to provide year-round (including winter period) water supply to the LLTUHB to enable work with autumn (hiemal) forms of sturgeon. It is expedient to use a recirculation system of water supply in the LLTUHB by which water arrives to a flow-through filter system after passing through the tanks. It is efficient to use zeolyte as a filter material, as it has proved to be not only a good mechanical filter substance but also a perfect sorbent of biological contaminants. After filtering and temperature regulation, the water is subjected to oxygenation in accordance with the broodstock's requirements at the prevailing temperatures (Figure 26).



**Figure 26:** Diagram of oxygen consumption intensity by sturgeons (Kazansky, 1975).

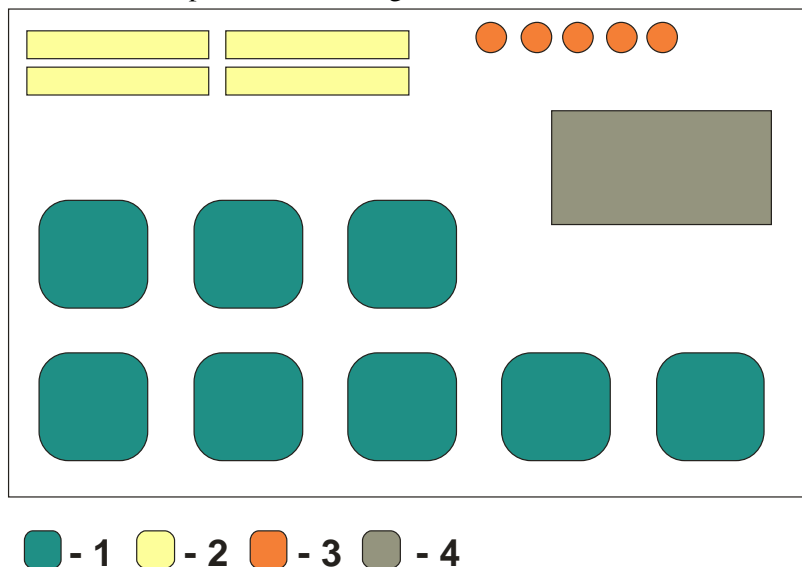


Besides the holding tanks, the LLTUHB should be equipped with incubation systems and a tank unit for short-term holding of hatched prelarvae and their adaptation to ambient temperature conditions. The water supply of this unit should be conducted through UV-light sterilization systems.

#### 2.4.3 Incubation unit

An incubation unit comprises a room with incubation systems equipped with a water treatment system, a container for storage of water sufficient for 20 min of unit functioning, systems for heating and ventilation, a laboratory and a room for duty staff (Figure 27). Illumination in the incubation unit should be rather faint, due to direct light negatively affecting the embryonic development of sturgeon. Incubation and tank units should be equipped with both flow-through and recirculation system units. The latter should have systems of mechanical and biological filtration, thermoregulation, water degassing and oxygenation, and UV-sterilization.

**Figure 27:** Common layout of an incubation unit: 1 – tanks for short-term holding of broodstock after hormonal stimulation; 2 – incubation systems; 3 – systems for egg de-adhesion; 4 – place for mature gamete collection.



The design of the incubation unit should be in compliance with the selected type of incubation system.

#### 2.4.4 Pond unit

Ponds for rearing of sturgeon fry should be of rectangular shape with a side ratio of 1:2 or 1:3. Their pond surface area ranges from 1–4 ha, while the maximum depth is 2.5 m; the pond bed is slightly sloped. The system supplying water to the ponds consists of a main canal (line) and side branch lines to each pond. The water supply system should ensure a full water exchange cycle every 1–2 d.

#### 2.4.5 Live food production unit

The live food production unit comprises a tank plot for culturing of *Daphnia* and *Artemia*, as well as a room for oligochaete culture and a feed preparation building.

*Daphnia* and *Artemia* culture requires concrete tanks having dimensions of 12 x 3 x 0.7 m. The water treatment system for each tank is autonomous, the water inlet being at one end of the tank and the outlet at the other. The tank bottom is even and slopes slightly. A special isolated room with natural illumination and constant temperature and humidity should be constructed for oligochaete culture. The size of the room is determined by the production capacity of the hatchery and its live food demand. The live food production unit should be located in the vicinity of the tank unit.



### 2.4.6 Unit for adaptation of wild breeders to artificial holding conditions

As part of the hatchery design, a separate unit or a part of the LLTUHB can be used for adaptation of wild breeders to artificial holding conditions. The latter option is more favourable because it allows wild breeders to be held at lower water temperatures. Regardless the scheme selected, conditions placing minimal stress on the fish should be ensured, including full shading and a natural regime of illumination.

### 2.4.7 Unit for broodstock development

In order to conduct broodstock holding operations, the hatchery design should incorporate a unit with flow-through concrete ponds of shallow depth (0.5–0.7 m) and an area of 30–40 m<sup>2</sup> for fingerlings and concrete and earthen ponds of an area of 100–500 m<sup>2</sup> for mature age groups and broodstock. In cases where earthen ponds are used, their slopes should be secured by concrete slabs and the bottoms should be covered by a special geomembrane (Figure 28).

**Figure 28:** Earthen ponds with their beds covered by a geomembrane.



In addition to concrete ponds, the unit should contain plastic tanks for sanitary and prophylactic treatment of fish, as well as separate ponds for quarantine holding. The latter should be located separately from other hatchery units and its entrance must be equipped with a constantly functioning security system. The unit for broodstock development should have a year-round independent water supply.

## 2.5 HATCHERY WATER SUPPLY

Water supply may be flow-through or mechanical. For mechanical water treatment, operation of pump stations should be arranged on 20 h per d (average count) basis. The water supply system to each production unit should be autonomous.

Water supply calculations are performed to determine the water demand of the hatchery and to set rates needed for flushing of water intake facilities, canals, and inlet and outlet system. The calculations should consider the area and volume of the ponds, tanks and other water treatment objects, the water exchange demand, the climate of the construction location (precipitation, evaporation and filtration-related losses) and hydrogeological data (e.g. seasonal variations in level and temperature of ground water).

## 2.6 WATER QUALITY REQUIREMENTS AT STURGEON HATCHERIES

The water supplied to sturgeon hatcheries should be of high quality. It is important to ensure that the levels of harmful substances and impurities are below threshold values and in compliance with the physical and chemical water quality requirements (Table 4) recommended for the breeding and rearing of sturgeons.

**Table 4:** Water quality parameters.

Parameter	Threshold value
Transparency	30 cm
Chromaticity	30°
pH	6.5–7.5
Carbon dioxide (CO <sub>2</sub> -free)	10.0 mg/liter
Dissolved oxygen	4.0 mg/liter
Permanganate oxygen consumed	10.0 mg O <sub>2</sub> /liter
Hydrogen sulfide	0.002 mg/liter
Calcium	180 mg/liter <sup>1</sup>
Magnesium	40 mg/liter
Cadmium	0.003 mg/liter
Iron	0.01 mg/liter
Lead	0.003 mg/liter
Zink	0.03 mg/liter
Sodium + potassium	120 + 50 mg/liter
Chlorides	30 mg/liter
Sulphates	50 mg/liter
Phosphates	0.3 mg/liter
Hydrocarbonates (Alkalinity)	7.0–8.0 mg equiv./liter 1.0 – 5.0 mmol/liter
Ammonium (NH <sub>4</sub> <sup>1</sup> )	0.5 mg/liter
Ammonia nitrogen (NH <sub>3</sub> )	0.003 mg/liter
Nitrite	0.1 mg/liter (soft water) 0.2 mg/liter (hard water)
Nitrate	1.0 mg/liter
Hardness	6.0–8.0 mg/liter
Biochemical oxygen demand (BOD <sub>5</sub> )	2.0 mg O <sub>2</sub> /liter
Suspended solids	10.0 mg/liter

<sup>1</sup>Yumurtaların döllenmesi ve inkübasyonu için sınır seviye (en uygun Ca<sup>++</sup> seviyesi) konsantrasyonu 6 ila 18 mg/L aralığında değişir.

## **2.7 RECOMMENDATIONS ON THE STRUCTURAL IMPROVEMENT OF EXISTING HATCHERIES**

When reconstructing existing sturgeon hatcheries, it is necessary to ensure implementation of a modern technological scheme and make corresponding changes in hatchery infrastructure that will enable:

- conservation of species and infraspecies genetic diversity of wild sturgeons;
- lowering of stress on fry and broodstock (by using low stocking densities, natural photoperiod and reducing other stressors), enabling a considerable decrease in the use of veterinary medicines through improved rearing biotechnology;
- a more efficient adaptation of reared juveniles prior to their release into natural waterbodies (increased swimming activity, light, noise, etc.);
- evaluation of their survival rates in natural waterbodies, using the system of multifunctional criteria (behavioural assessment of juvenile quality); and
- mass tagging of juveniles using serial tags that cause minimal exposure to stress.

The future lines of technological improvement should comprise, among other elements, the alteration of methods intended for controlled maturation without exogenous hormonal stimulation, i.e. the development of ecologically sustainable methods for simulating artificial reproduction under the hatchery conditions, as well as egg incubation in an adhesive state (thus avoiding de-adhesive treatment and active moving during embryogenesis). Some steps in this direction have been taken through the development of an artificial spawning ground that ensures optimal hydrological conditions of pseudo-migration of broodstock with the possibility of annual clearance of artificial substrate, rearing of larvae, etc. (see Annex II).

## Chapter 3

### Collection and transportation of wild breeders

#### 3.1 SITES AND PERIODS OF BREEDER COLLECTION

The initiation of collection of wild breeders depends on the time of migration of the various sturgeon species to the coastal areas and into the river mouths. The collection of breeders should cover the entire period of the spawning migration and include all intraspecific groups (autumn, vernal, etc). Broodstock collection should be performed in rivers during anadromous migration to the spawning sites using trap nets and fishing nets in coastal areas.

#### 3.2 TRANSPORTATION OF BROODSTOCK TO HATCHERY

Sturgeon are transported from the traps to fishery boats using cradles equipped with special gloves or nets. The fish are then transported to the live fish vessel or to sites of loading onto trucks for fish transport. The transportation time of breeders in a so called “prorez” (a special vessel with holes) (Figure 29) or hatchery vessels should be limited to the shortest possible (maximum 1 d for live fish vessel transport, and 6 h for transport by live fish truck).

**Figure 29:** Special live fish vessel “prorez” with many holes ensuring water exchange between the river and the vessel, with a tugboat beside it.



Containers for broodstock transportation should be rinsed with freshwater and subjected to disinfection. To avoid damage to fish, any defects of the inner surface of the containers should be eliminated. Unloading of the broodstock should be performed using a hoisting system (crane, winch) in canvas containers with water.

### 3.3 TAGGING OF WILD BREEDERS

Breeders of different spawning runs are characterized by different fat deposition, stage of maturity and response to hormonal stimulation. Therefore, it is essential to tag individuals with internal tags (PIT tags are preferable) and with external tags (a second priority if internal tags are available). The accompanying data should include the place (river/sea) and time of capture, distinguishing groups of early, middle (mass run) and late anadromous migrants. Lack of tags with capture time indication can lead to improper spawning selection, resulting in decrease in the number of fully mature females and high mortality of larvae and fingerlings. Tag data related to location and period of collection should be recorded.

### 3.4 MAIN BIOLOGICAL AND REPRODUCTIVE INDICES OF WILD BREEDERS

Breeders captured in the wild differ considerably from farmed fish in a range of main biological and hatchery parameters (Table 5).

**Table 5:** Main hatchery indices of wild breeders (at egg extraction).

Species	Relative fecundity, eggs (x 1 000) /kg	Gameto-somatic index, %	Oocyte weight, G	Fertilization rate of eggs (at stage of large yolk plug), %
Russian sturgeon	9.5–9.7	19.5–20.0	18.0–23.0	81.5–87.3
Stellate sturgeon	12.5–13.5	20.0–21.0	8.5–12.5	85.0–87.0
Beluga sturgeon	3.9–4.2	10.0–12.0	25.0–30.0	81.0–86.0

---

## Chapter 4

### Broodstock management

#### 4.1 INTRODUCTION

Preparation of sturgeon wild breeders (spawners) intended for a hatchery breeding programme may be divided into the following stages:

1. autumn assessment of farmed broodstock or collection of autumn-run wild breeders;
2. broodstock overwintering;
3. spring assessment or collection of spring-run wild breeders;
4. pre-selection of spawners;
5. maintenance of proper temperature and prespawning holding regimes; and
6. examination of broodstock prior to hormonal stimulation.

In cases where gametes are obtained from a broodfish out of season, a different technological scheme should be applied. While working with broodstock, it is important to consider both their gross morphological characters and special methods to evaluate the reproductive state of males and females. The methods of collection of feral breeders at defined capture areas have been reported in detail in relevant guidelines that take into account the peculiarities of a certain basin or region (Anon., 1986). It is beyond the scope of this manual to cover in detail these methods. It is, however, essential to consider the aspects of captive broodstock management, as this, unfortunately, will be the main source of fertilized eggs for Ponto-Caspian sturgeon hatcheries in the near future. The obvious objective of the broodstock autumn assessment is to select fish able to produce high quality mature gametes in the forthcoming spawning season. As the successful completion of gametogenesis depends upon many factors (overwintering conditions, thermal regime in spring, fattening, etc.), therefore some fish selected during autumn assessment may be sorted out in spring.

In order to identify a proper regime of prespawning holding and gamete collection, the selection of spawnable breeders is performed during the spring assessment. During this evaluation, any immature or overmature broodstock will be sorted out.

#### 4.2 LATE AUTUMN ASSESSMENT

##### 4.2.1 General considerations

In autumn, the females with gonads at maturity stage III, III–IV and IV, and males at stage III–IV and IV are selected for possible use in reproduction. The males of beluga (*H. huso*) after the current-year spawning should not be reserved for the

next spawning campaign. While doing the autumn assessment, it is desirable to separate from the major group of mature females or to mark:

- the first maturing females;
- fish with gonads at maturity stages III and III–IV; and
- very mature or emaciated (after a warm winter) fish that will be ready for spawning before the rest.

The autumn assessment of broodstock and older replacement is performed as the water temperature decreases to 12 °C, at which point feeding of fish is usually stopped (Figure 30).

**Figure 30:** Autumn assessment of broodstock.



To select the females during the autumn assessment, it is optimal to apply a noninvasive ultrasonic express technique for determining gonad maturity stages (Chebanov, Galich and Chmyr, 2004; Chebanov and Galich, 2009, 2010). In the absence of an ultrasonic examination scanner, the selection is performed by bioptical, operative or endoscopic study of gonads, which requires much more time and results in fish damage. The proper assessment requires a good awareness of sturgeon gonads development stages..

#### 4.2.2 Gonad maturity stages in sturgeons

At present, few classifications of gonad maturity stages have been developed. These vary in details and the number of stages described (Trusov, 1964; Shilov,



1971; Kukuradze, Kirilyuk and Salnikov, 1975; Conte *et al.*, 1988; Williot, Brun and Rooryck, 1991; Vaini, Pazzaglia and Ruzza, 2001). The most detailed classification was suggested by Trusov (1964), with not only identification of single stages but also of substages of gonadogenesis. This classification is applied at examination of sex and maturity stage in sturgeons by using the ultrasound technique (Chapter 14). The generalized scale of sturgeon maturity stages presented below (Conte *et al.*, 1988) is that which has been most frequently mentioned in relevant English literature sources (Table 6).

**Table 6:** Classification of gametogenic stages in the white sturgeon (Conte *et al.*, 1988).

Stage	Female	Male
1	Differentiated ovary consists of fatty adipocytes, with oogonia and primary oocytes at the periphery of ovigerous fold. Primary oocytes are small (50 $\mu\text{m}$ in dia) and contain large nuclei with condensed chromatin.	Testes are composed of adipose fatty tissue with a thin (3–5 mm) cord of germinal tissue containing dividing spermatogonia, loosely arranged in cysts.
2	At least 50 percent of ovarian tissue consists of growing oocytes, ranging from 100–250 $\mu\text{m}$ . Gonial cells are almost absent. Cytoplasm is strongly basophilic and contains large vesicles in the cortex area, staining for carbohydrates. There are numerous nucleoli and often lampbrush chromosomes in the nucleus.	Germinal portion of testis is enlarged (approximately one-third of gland volume) and consists of well-differentiated cysts containing primary spermatocytes.
3	Little or no fatty adipocytes remain in the ovary. There are two clutches of germ cells, one as described for Stage 2 and another consisting of differentiated oocytes 800–1 200 $\mu\text{m}$ in dia. Oocyte cytoplasm is eosinophilic and contains yolk platelets. One- or two-layered zona radiata and two-layered follicular envelope are differentiated. Nucleus with diffused chromatin and small numbers of nucleoli. There is no pigment in the cortex area.	Testes are enlarged, with about one-third of fatty tissue. Cysts contain various meiotic stages, from primary spermatocytes to spermatids. In some, a small number of ripe spermatozoa are present.
4	There are two clutches of oocytes, one as described in Stage 2, another represented by large black eggs of 3 500–4 000 $\mu\text{m}$ dia. Cytoplasm is filled with platelets and oil droplets and contains melanin pigment granules in the cortex area. Envelope consists of two-layered zona radiata and thick gelatinous coat. As follicle ripens, the egg becomes polarized and the enlarged nucleus (germinal vesicle) migrates to the animal pole.	Testes are greatly enlarged, containing little or no adipose tissue. All cysts and ducts are filled with mature spermatozoa.



Moreover, the classification presented in Bruch, Dick and Choudhury (2001) has been used during the special workshops devoted to sexing and gonad maturity staging in sturgeons within the framework of international sturgeon symposia (e.g., in Oshkosh, United States of America in 2001 and in Ramsar, Iran in 2005). The results of comparison between Bruch, Dick and Choudhury (2001) and Trusov's classifications are given in the Table 7.

**Table 7:** Comparison between female (F) and male (M) stages of maturity (1–6) in sturgeons. Key: F – maturity stage in female, M – maturity stage in male.

Author	Sex	Gonad maturity stage						
		F virgin	F1	F2	F3	F4	F5 spawning	F6 post-spawning
Bruch, Dick and Choudhury, 2001	Female	F virgin	F1	F2	F3	F4	F5 spawning	F6 post-spawning
Trusov, 1972	Female	F1	F2, F2sf, F2f	F2–3	F3	F4i, F4c	F5 spawning	F6 post-spawning
Bruch, Dick and Choudhury, 2001	Male	M virgin	M1	M2	M3 Spawning			
Trusov, 1972	Male	M1	M2, M2sf, M2f	M3, M4	M5 spawning			

#### 4.2.3 Methods for broodstock preselection

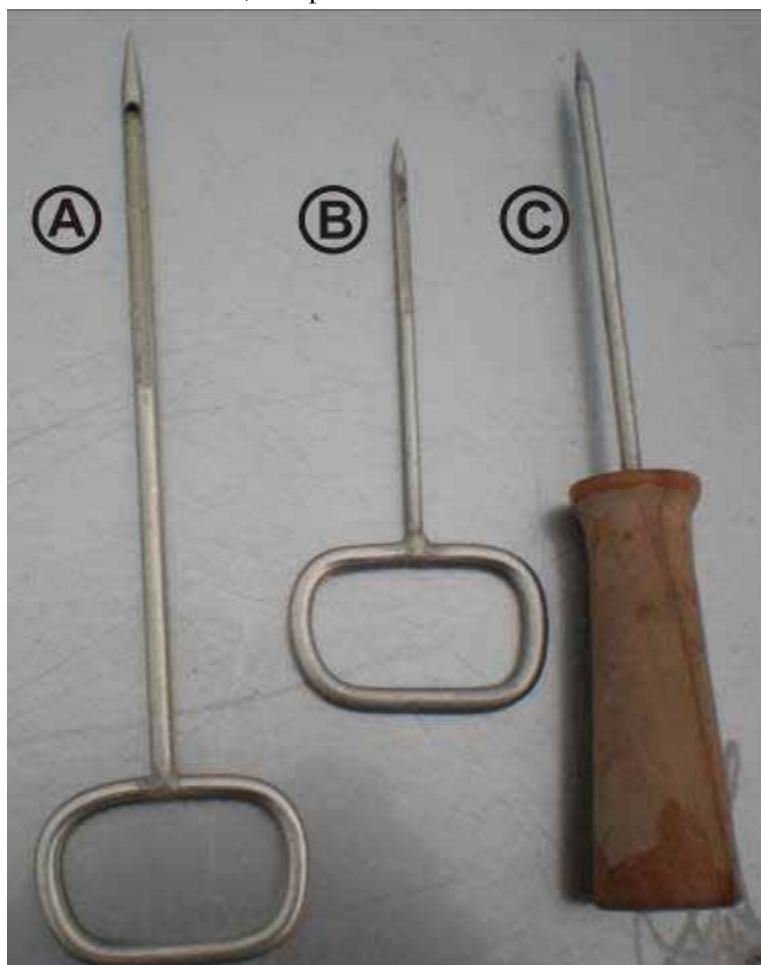
It is well known that external sexual dimorphism is not apparent in sturgeon before sexual maturity (Dettlaff, Ginsburg and Schmalhausen, 1993; Doroshov, Moberg and Van Eenennaam, 1997). At present, different techniques of immature sturgeon sexing and gonad staging are available, apart from the ultrasound methods. Among them are:

- biopsy and closely related methods;
- endoscopy;
- immunochemical assays (sex steroids level analysis);
- method of Fourier transform infrared spectroscopy; and
- morphometry.

##### 4.2.3.1 Biopsy

The biopsy of gonads is by introduction through the abdominal wall or through the lateral muscles of a special steel probe (diameter for Russian sturgeon – 4.5–5 mm; for beluga – 5.5–6 mm; for stellate sturgeon, ship and sterlet – 3–4 mm; groove length – 3–6 cm). To avoid damage of the inner organs and for easier sampling of a gonad particle, it is wise to make a skin puncture by use of a pricker (Figure 31), with subsequent sampling using a probe.

**Figure 31:** Instruments used for biopsy of sturgeon gonads in Russia: **A, B** – probes of different diameter; **C** – pricker.



Before sampling, the probe should be disinfected. It should be inserted between the rows of lateral and abdominal scutes at the third part of the abdomen at an acute angle to the body axis to a depth of 5–7 cm. At probe torsion, some gonadal tissue is left in the cut (Figure 32).

**Figure 32:** **A** – Sampling of stellate sturgeon using biopsy probe, **B** – probe with sample of an ovary at maturity stage IV.



In the United States of America, egg samples are collected with a catheter (4.5 mm ID rigid Teflon tubing) through a small (6–8 mm) abdominal incision (Conte et al., 1988; Parauka, 1993; Webb *et al.*, 2009) (Figure 33).

**Figure 33:** Egg sampling with the use of a catheter through a small abdominal incision (**A** – from Parauka, 1993; **B** – from Webb *et al.*, 2009).



Fat tissue is prevalent in the gonads of fish at periods of intensive feeding, so it may be a problem to hit the germinal part of the gonad. Thus the application of this technique is generally restricted to the diagnostic sampling of mature females beginning from maturity stages II–III and III.

It is recommended to consider follicle size as a determinant at preliminary selection of mature females with the use of biopsy of sturgeon broodstock (Williot and Brun, 1998; Williot, 2002). For example, females with an oocyte diameter of more than 2.6 mm (stellate sturgeon), 2.8 mm (Siberian and ship sturgeons) and 3.2 mm (Russian sturgeon) have a chance to reach maturity in a few months. The maturation stage should be verified in the course of spring broodstock assessment. It is possible to consider the minimal weight of an oocyte in the sample as a selection criterion for mature females (Russian sturgeon – 16 mg, beluga – 22 mg, stellate sturgeon – 11 mg, ship sturgeon – 13 mg, sterlet – 8 mg) (Trusov, 1972). In order to distinguish fat from testicular tissue, the tissue biopsy sample should be placed into 4 percent formalin. A piece of fat floats, while testicular tissue sinks (Chapman, cited by Parauka, 1993), allowing the type of the sample tissue to be visually assessed (Conte et al., 1988; Parauka, 1993; Van Eenennaam and Doroshov, 1998). The biopsy technique is time consuming and stressful for the fish. Using anesthetics when taking a biopsy can result in harmful circumstances and infections in fish. Inevitably, the biopsy method will cause losses (up to 5 percent of fish) due to associated infections.

#### ***4.2.3.2 Direct palpation and laparoscopy***

Examination of gonads can be conducted by palpation. Sex determination involves the careful insertion of a finger through the cut into the body cavity (Figure 34) in order to determine the tissue structure of the gonad by touch (Bruch, Dick and Choudhury, 2001).

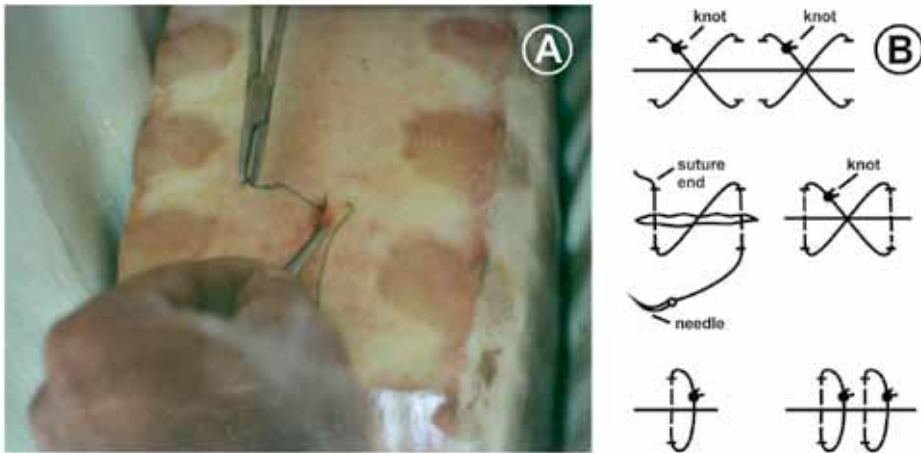
**Figure 34:** Direct palpation of an ovary (Bruch, Dick and Choudhury, 2001).



The direct palpation technique enables easy differentiation of gonads in females and males (Figure 34) weighing 7–9 kg (3–4 years of age, in the case of white sturgeon) according to Van Eenennaam, Bruch and Kroll (2001). A qualified operator can perform 300 to 500 sex identification procedures per day. The testis is covered by a thin membrane that is smooth to touch, while the ovary is not membrane-bound and its surface is rough and shaggy (folded). The differences in the structure of gonadal tissue between females and males are evident during all stages of sexual development (Trusov, 1972; Conte *et al.*, 1988; Van Eenennaam, Bruch and Kroll, 2001). The shortcomings of this technique are similar to those of biopsy.

A modification of this method is the direct palpation of gonads through an operative opening. The accuracy of this method is somewhat higher as compared with biopsy, but it is more traumatic, requires the application of operative sutures (Figure 35) and is more time consuming.

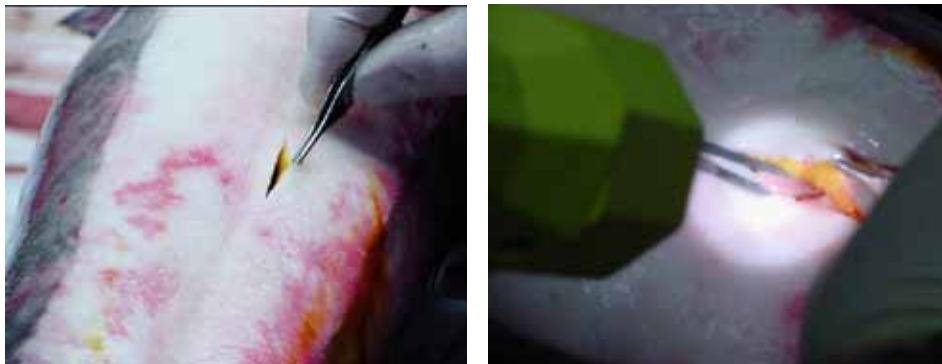
**Figure 35:** LExample of suturing after laparoscopy application: **A** – suturing of Atlantic sturgeon (*Acipenser oxyrinchus*) (Parauka, 1993); **B** – ways of suturing (Conte *et al.*, 1988).



Suture materials may play an important role in surgical examination (and laparotomy) because they provide tissue support for healing of the wound. Different types of material are available for wound repair (Wooster, Hsu and Bowser, 1993). Chapman and Park (2005), who studied the Gulf of Mexico sturgeon *A. oxyrinchus desotoi*, evaluated the absorbable Polyglactin 910 (Vicryl), Polydioxanone (PDS II) #1 and Panacryl materials and the nonabsorbable Ethibond sutures to close abdominal skin incisions after gonad biopsies by CP-1 cutting needle.

When employing the laparoscopy technique, a small incision (about 2 cm) is made in the abdominal wall of the tested individual (Figure 36).

**Figure 36:** Laparoscopy.



It is then possible to visually determine the type of tissue using an otoscope with lighting (Figure 37) (Conte *et al.*, 1988; Powell, 2008).

**Figure 37:** Otoscope for direct examination of sturgeon gonads during laparoscopy.



#### **4.2.3.3 Endoscopy**

Endoscopic study implies visual identification of sex and maturity stages and is a more advanced method to study gonads in sturgeon (Ortenburger, Jansen and Whyte, 1996). This technique allows the visual study of gonads with the help of surgical diagnostic tools used for the medical examination for diseases of the urogenital system such as the cystoureteroscope or borescope (Figure 38).



**Figure 38:** Endoscopic system used for determination of sex and gonadal maturity status.



Gonadal examination is performed by means of the fiber optic system of the device. The resolution of the technique is very high; detailed structure and tissue coloring are well visualized by means of the optical system of the device (Safronov *et al.*,2006). A probe of the cystoureteroscope is introduced into the body cavity through the genital opening, hence the diameter and length of the probe should correspond to the urogenital opening and gonoduct sizes. Examination of immature fish requires probe insertion via a small abdominal incision (0.5–1 cm) made at two to three scutes from the tail on the left side of the fish (Figure 39).

**Figure 39:** Sexing of immature sturgeon by introduction of borescope probe through an incision into the body cavity.

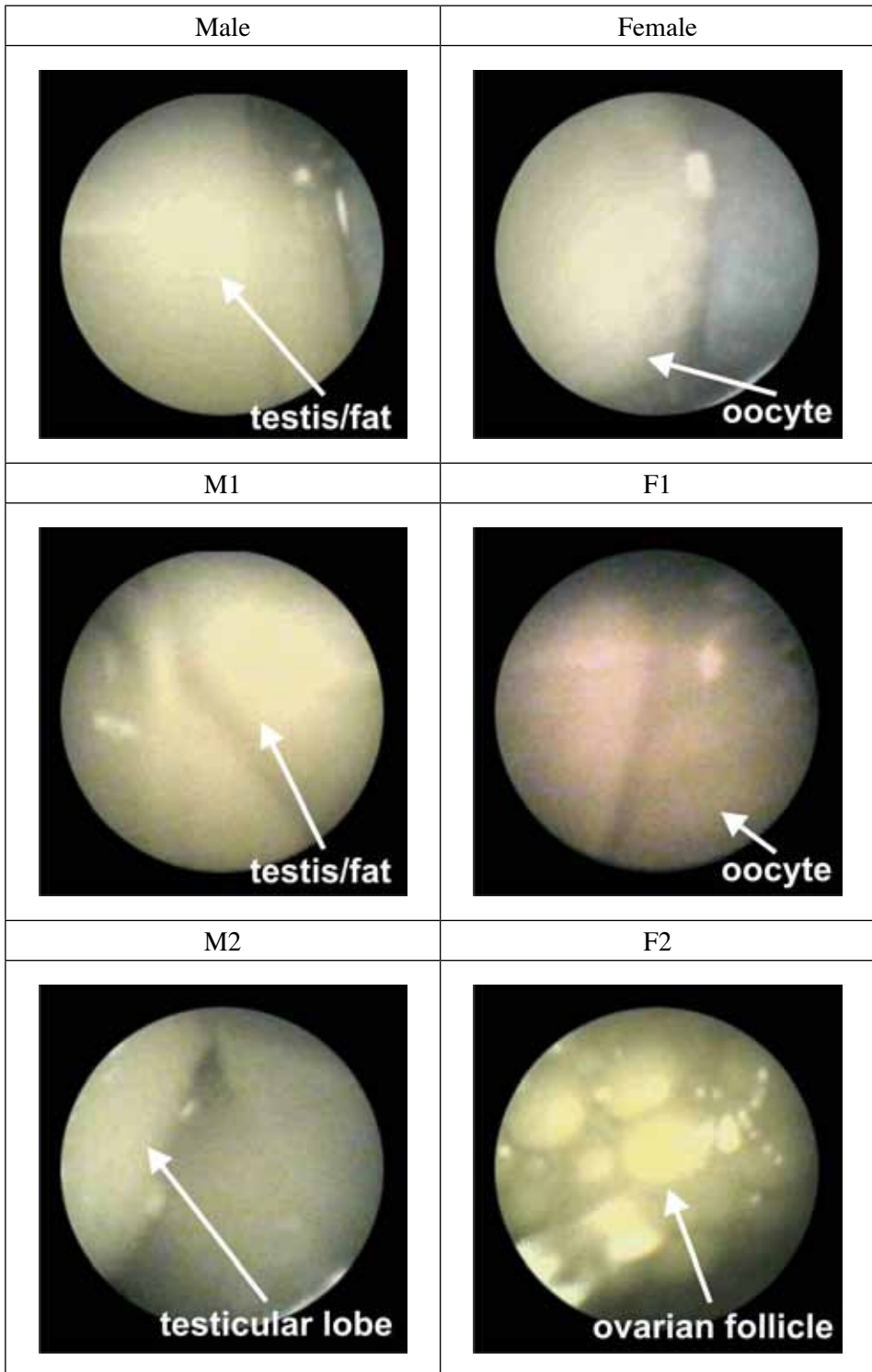


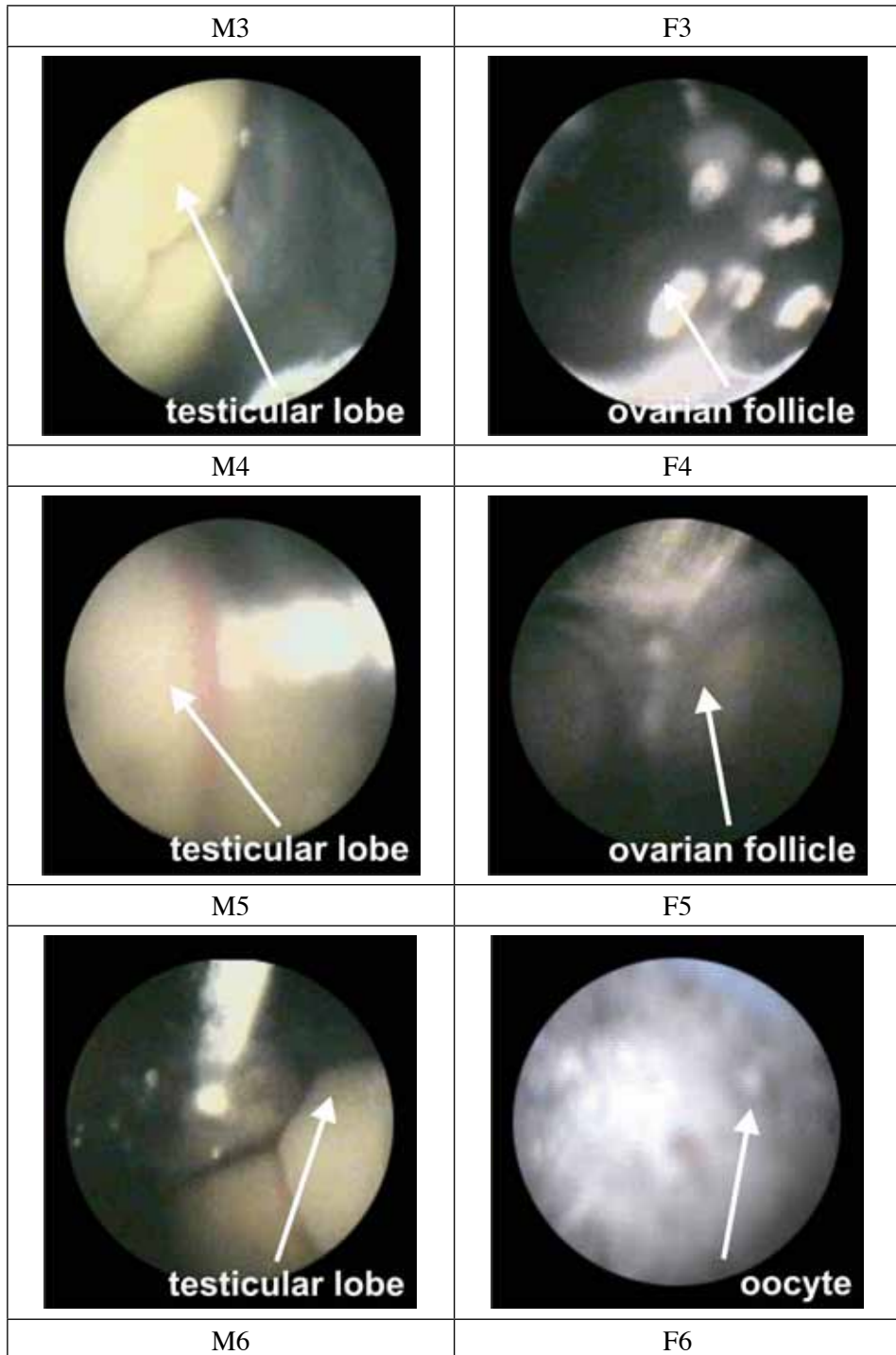
Good results have been obtained using borescopes of 4 mm in diameter (Kynard and Kieffer, 2002). The standard minimal focal length of the borescope is 1 mm, thus it is recommended to use focal rings in order to enhance focusing ability (Kynard and Kieffer, 2002). Without these rings, the image will be indistinct at contact of the probe with the tissue of the urogenital duct wall. It is also essential to limit the depth of probe insertion into the body cavity (using flexible probes) to avoid damage of the oviduct funnel valve. Because the oviduct length amounts to 14–16 percent of the body length, application of a 16 cm borescope is recommended for middle- sized fish, while 25 cm probes are to be used for very large fish (Kynard and Kieffer, 2002).

In order to avoid injury to internal organs while using endoscopy, all fish, even small ones, need to be fully immobilized with an anesthetic. Investigations can also be conducted in small ponds. In this case, the fish must be turned over on its back, leaving its head submerged in water. The probe of the borescope should be inserted into the genital opening and further to the right or left oviduct parallel to the longitudinal axis of the body, adjusting the location of the probe in the body visually through the lens.

Gonads of sturgeons at I–II developmental stages are evident as homogeneous tissue of pink and orange colour (Figure 40).

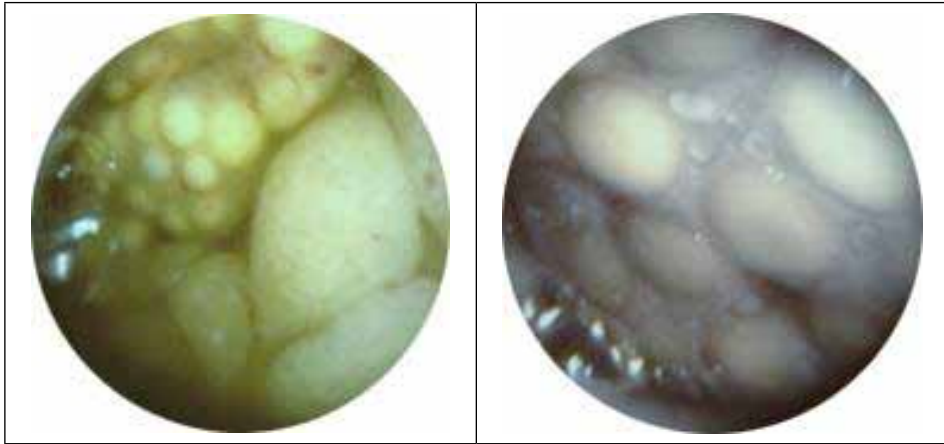


**Figure 40:** Endoscopic views of gonads of stellate sturgeon at different stages.



At later stages, pink, orange and dark eggs as well as oocytes of the senior generation are well discernable (Figure 41).

**Figure 41:** Endoscopic view of oocytes.



Hurvitz *et al.* (2005) have shown that the sex of a sturgeon can be identified with this system as early as three years of age (in this study, the percentage of fish for which the sex could not be determined was 5 percent). The accuracy of sturgeon sexing was as high as 98 percent, while traumatism in fish that were operated on by endoscope through an abdominal cut occurred in 2 percent of cases. Cicatrization of the peritoneum takes two weeks.

As distinct from the biopsy techniques, endoscopy has the following advantages:

- minimal invasiveness of the approach;
- possibility of application in field conditions;
- short duration of examination procedure;
- feasibility to separate fish capable of spawning during the current season from immature ones; and
- ease of mastering.

Note that this method application has a few shortcomings. The most important of these is that sex identification requires assessment of the appearance of the germinal tissue and hence, it is often impossible to distinguish the gonads of males from those of females at early developmental stages (Figure 40). It is optimal to use endoscopy while working with mature females for accurate determination of their “spawnability” and egg maturity status. It is not wise to use this technique for male assessment. The advantage of all anatomical methods is the low cost of the equipment, while a drawback is their traumaticity. Intervention into the body cavity may have not only detrimental effects on the physiological condition of fish, but is also a strong stress factor. In addition, the operative methods require further monitoring of the condition of fish and the healing of operative sutures (Chapter 5).

#### 4.2.3.4 Immunochemical assays (sex steroids level analysis)

This alternative, minimally invasive technique for live early sexing of fish, which estimates the level of sex steroids such as testosterone (T), 11-ketotestosterone (11KT) and estradiol (E2 or 17 $\beta$ -estradiol) in the serum of wild (Webb *et al.*, 2002; Ceapa, Williot and Bacalbasa-Dobrovici, 2002; Barannikova, Bayunova and Semenkov, 2005; Semenkov *et al.*, 2005) and farmed (Amiri *et al.*, 1996; Akhundov, 1997; Semenkov *et al.*, 2006) sturgeons has been widely used. Akhundov (1997) reported that this technique allows sex differences (associated with T and E2 concentration in the blood serum) to be revealed in male stellate sturgeon juveniles as early as the moment of cytological differentiation of gonads (i.e. at an age of 10–12 months, as evident from Table 8).

**Table 8:** Variations in level of blood serum sex steroids in stellate sturgeon fingerlings at different stages of gonad development (Akhundov, 1999).

Age, months	Sex	Weight, g	State of gonad	Estrogen (E2), ng/ml	Testosterone (T), ng/ml	E2/T
2	♀	3.3 ± 0.42	early differentiation	1.0 ± 0.1	8.5 ± 0.3	1/8
	♂	3.1 ± 0.37	early differentiation	1.0 ± 0.1	8.3 ± 0.5	1/8
3	♀	11.1 ± 0.75	early differentiation	2.6 ± 0.2	17.3 ± 0.6	1/7
	♂	11.3 ± 0.67	early differentiation	2.3 ± 0.2	18.8 ± 0.9	1/8
4	♀	30.5 ± 2.26	anatomical differentiation	4.0 ± 0.5	31.6 ± 1.5	1/8
	♂	29.8 ± 2.18	early differentiation	4.3 ± 0.4	32.1 ± 1.6	1/7
5	♀	55.7 ± 3.09	cytological differentiation	5.8 ± 0.4	47.3 ± 2.3	1/8
	♂	54.6 ± 3.78	anatomical differentiation	5.5 ± 0.3	44.8 ± 1.9	1/8
7	♀	69.9 ± 4.59	cytological differentiation	7.6 ± 0.7	59.7 ± 2.9	1/8
	♂	68.3 ± 4.21	anatomical differentiation	6.6 ± 0.5	55.7 ± 2.2	1/8
10	♀	121 ± 8.3	maturity stage I–II	<u>14.7 ± 1.0<sup>1</sup></u>	<u>93.4 ± 7.6</u>	<u>1/6</u>
	♂	120 ± 7.9	cytological differentiation	<u>7.2 ± 0.5</u>	<u>185.6 ± 11.9</u>	<u>1/26</u>
12	♀	184 ± 12.1	maturity stage I–II	<u>15.8 ± 0.9</u>	<u>102.2 ± 6.9</u>	<u>1/6</u>
	♂	182 ± 14.7	cytological differentiation	<u>7.1 ± 0.6</u>	<u>208.3 ± 12.9</u>	<u>1/29</u>

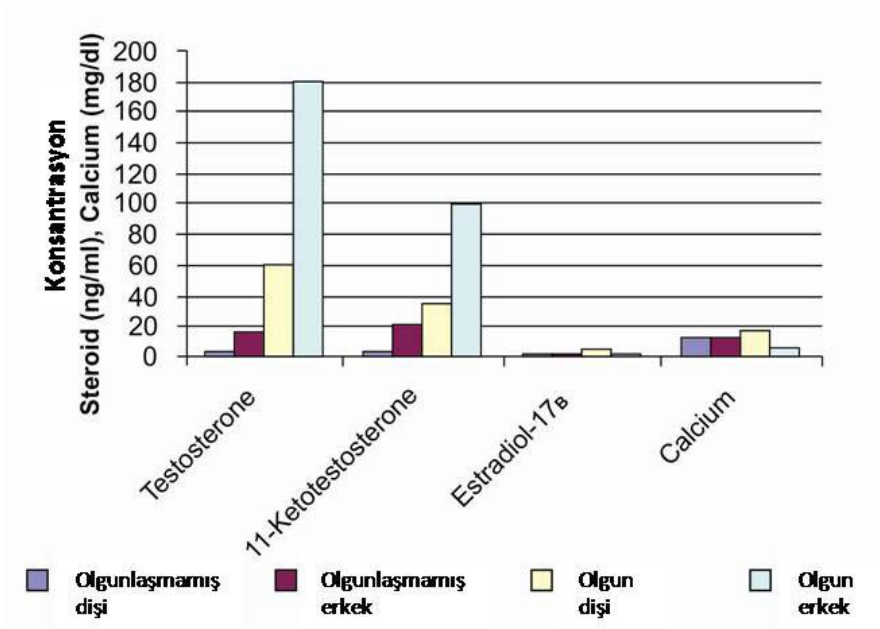
<sup>1</sup> Underlining indicates sharp differences in E2 and T values (and related E2/T ratio) between males and females. These differences facilitate the sexing procedure.

Webb *et al.* (2001) reported that the level of T in white sturgeon (*A. transmontanus*) males at maturity stage II was higher than that in females (Figures 42, 43). This characteristic enables early sex determination at different stages of maturity.

**Figure 42:** Determination of sex steroids concentrations (immunochemical assays) (Webb *et al.*, 2009).



**Figure 43:** Plasma sex steroids and calcium (as index of vitellogenin) concentrations in mature and immature wild white sturgeon (*Acipenser transmontanus*) (Webb *et al.*, 2002).



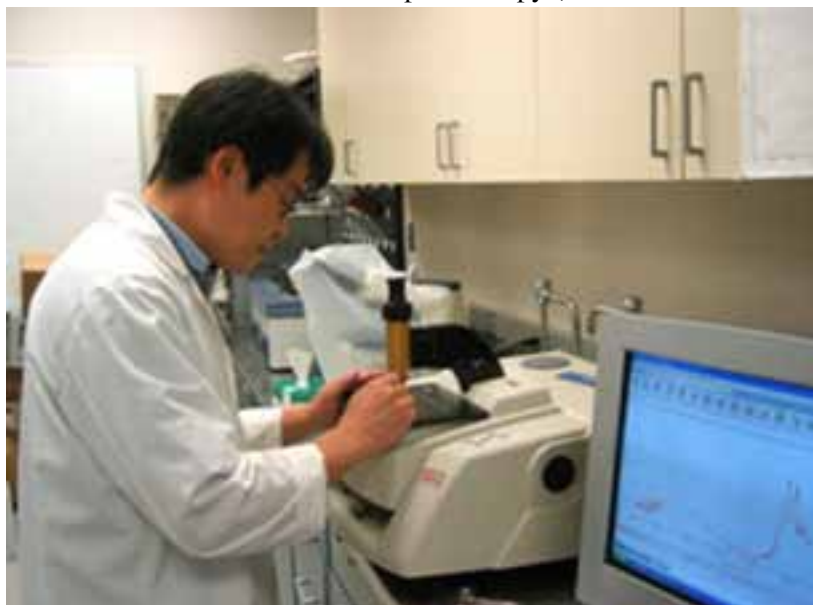
Semenkova *et al.* (2006) confirmed this conclusion, but indicated that the effective and reliable application of this technique requires that the monitoring of the reproductive system state and the measurement of T, 11KT and E2 in females and males of various ages be performed at sturgeon farms of various types (pond, warm water, recirculating).

An important disadvantage of the endocrine technique is the high cost of its application in both field and laboratory conditions (Van Eenennaam, Bruch and Kroll, 2001). The blood analysis requires the availability of relevant equipment, a fish tagging system and extra labour for double sturgeon capture (initially for tagging and again for separation of females from males), as well as time for analysis (about 15 000–20 000 samplings at larger commercial farms).

#### ***4.2.3.5 Fourier transform infrared spectroscopy***

Recent research conducted by Webb *et al.* (2009) and Lu *et al.* (2010) has indicated that the potential of such approaches as radioimmunoassay and the measurement of plasma sex steroid, total calcium, plasma protein, etc. can be enhanced by application of Fourier transform infrared spectroscopy (FT-IR) to predict the ovarian stage of white sturgeon (Figure 44).

**Figure 44:** Fourier transform infrared spectroscopy (from Webb *et al.*, 2009).



Clear differentiation of maturity stages (previtellogenesis, vitellogenesis, postvitellogenesis and follicular atresia) was achieved with the use of principal component analysis (PCA). Progression of oocyte development in the late phase of vitellogenesis was also controlled using PCA based on changes in plasma concentrations of sex steroid and lipid content. According to these results, FT-IR may be a good tool for assessing ovarian maturity in farmed sturgeon and will



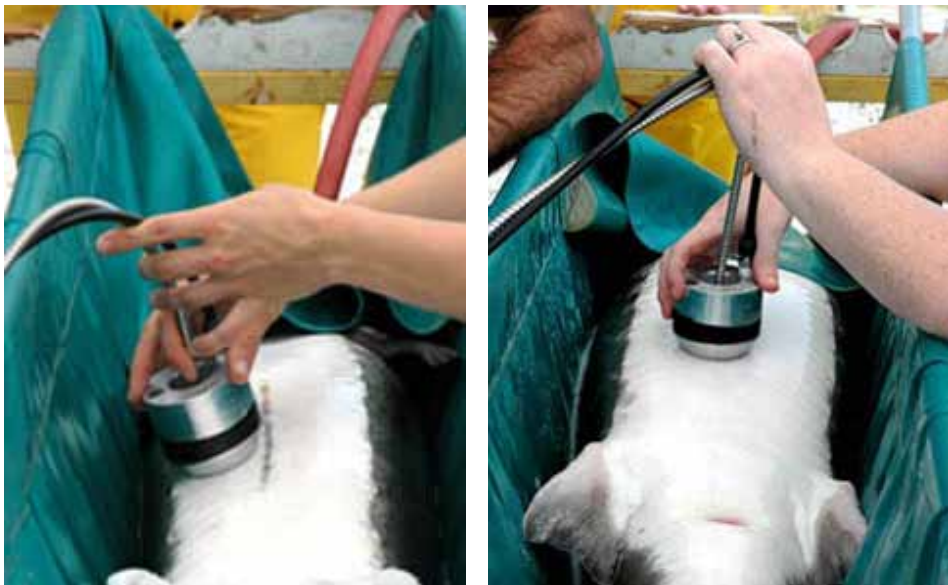
reduce the need for the invasive ovarian biopsy required for polarization index (PI) determination. Thus according to preliminary results, spectral analysis of blood plasma by FT-IR may be used in lieu of a biopsy and the calculation of oocyte PI (Section 4.4.2.1).

As mentioned above, the method requires that during the blood sampling all the fish should be tagged. When the results of analysis are obtained, the fish should be recaptured in order to separate sexes. This procedure proved to be labour intensive to some extent, often resulting in mistakes during the tagging in hatcheries.

#### 4.2.3.6 Short wavelength near infrared spectroscopy

In the most recent studies of Webb *et al.* (2009) and Lu *et al.* (2010), the potential of the noninvasive short wavelength near infrared spectroscopy (SW-NIR) technique to predict sturgeon maturity by taking spectra of gonads was reported. In the course of studies on live anesthetized white sturgeon, the probe was placed on the abdominal area and moved around in correspondence to the placement of the ovary (Figure 45).

**Figure 45:** Noninvasive SW-NIR spectral acquisition on anesthetized white sturgeon (from Webb *et al.*, 2009).



Spectra may be acquired using a ProSpectra spectrophotometer equipped with an illuminating tungsten lamp and a central collection fiber-bundle. Spectra are collected in diffuse reflectance mode over a wavelength range from 600 to 1100 nm. Before spectra are acquired on the sample, dark and reference spectra should be obtained (Webb *et al.*, 2009; Lu *et al.*, (2010). For comparative spectral analysis, during each sampling, 30 cm<sup>3</sup> of eggs were surgically removed from each female and transferred in a Teflon holder for spectral acquisition (Figure 46).

**Figure 46:** Set up for SW-NIR spectral analysis of eggs of white sturgeon (from Webb *et al.*, 2009).



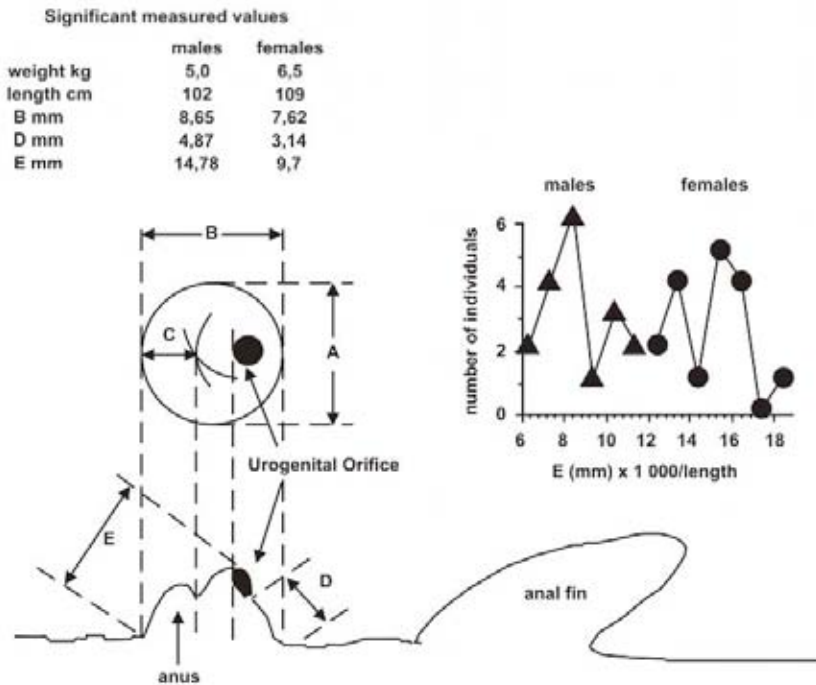
According to preliminary results (Webb *et al.*, 2009), abdominal scans by SW-NIR may be applied for detecting maturity stages in sturgeon as well as for timely prediction of follicular atresia.

#### **4.1.3.7 Morphometry**

The method of sexing using urogenital region morphometry has been described by Fuji *et al.* (1987, cited by Billiard, 2002). Some sex differences in the morphometric character (E) between the urogenital regions of female and male sturgeon (from 3 years of age) have been found. The main differences are significant for the E character, as is shown in Figure 47.



**Figure 47:** Method of sexing using urogenital region morphometry (Fuji *et al.*, 1987 – from Billard, 2002).



The accuracy of E index determination depends on the precision of angle measurements. This considerably decreases the practical value of this technique. The possibility of early sexing by using biometrical method has been shown for the example of subadult specimens of *A. ruthenus* (Figure 48) and *A. gueldenstaedtii* (Maltsev and Merkulov, 2006) from the sturgeon living gene bank of South Branch Federal Centre of Selection and Genetics for Aquaculture (Krasnodar, Russia). The discriminant equations obtained on the basis of this approach can enable easy sex determination of sturgeon.

Discriminant equation<sup>1</sup> for sex determination of adult *A. gueldenstaedtii*:

$$D^2 = - 36.7303 - 0.696098 I + 0.193362 Q + 101.344 I/Q + 12.5249 E/H$$

$$D^2 = a + b_1 X_1 + b_2 X_2 + \dots + b_p X_p$$

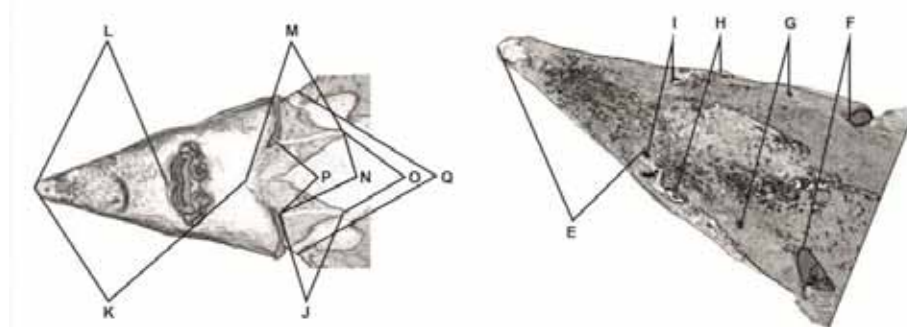
where,  $D^2$  = sample estimate of Mahalanobis distance (discriminant score);  
**a** = constant; **b<sub>1</sub>...b<sub>p</sub>**  
 = unstandardized coefficients; **X<sub>1</sub>...X<sub>p</sub>** = the predictor variable values; and  
**p** = variable number.

<sup>1</sup> A typographical error was made in the original paper (Maltsev and Merkulov, 2006); here we present a corrected formula.

The few most informative indices of craniological measurements (used in the equation) in live sturgeons have been statistically identified.

It should be noted that morphometrical techniques have not been fully developed and their application is presently of mere experimental character. That is why they cannot be recommended for wide use in sturgeon culture, despite their easiness.

**Figure 48:** The scheme of craniological measurements (Maltsev and Merkulov, 2006).



It should be noted that morphometrical techniques have not been fully developed and their application is presently of mere experimental character. That is why they cannot be recommended for wide use in sturgeon culture, despite their easiness.

#### 4.2.3.8 Revealing of some sexual dimorphism traits in adult sturgeons

As in the case of other fish species, attempts to identify external sex traits for sturgeon have been undertaken many times, but only partial success has been achieved in adult sturgeon. For many years, the following morphological criteria were used for selection of wild mature sturgeon females at Caspian Sea hatcheries (Milshtein, 1982):

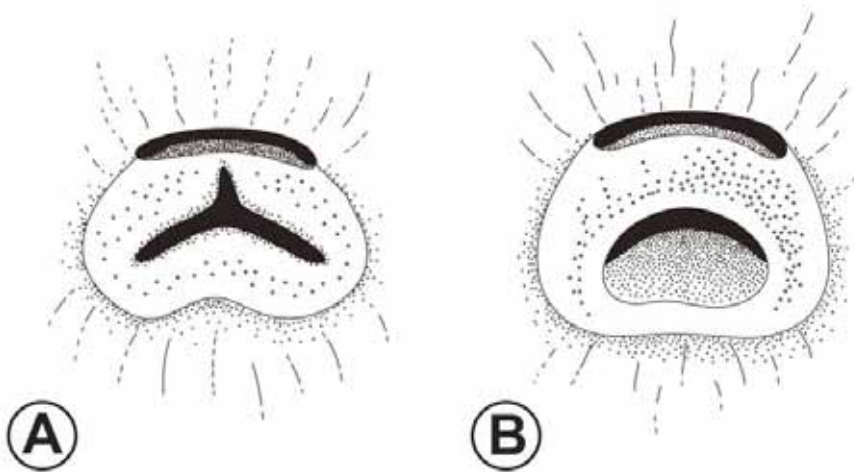
- Yfemales about to ovulate have a thick girth, while in less mature fish it is thinner and fatty;
- the tail has an oval shape from the rear part of the caudal peduncle to the caudal fin (this shape indicates fish with weight loss);
- the snout is sharp due to the narrow head and entire body; and
- the scutes are less acute, similar to females close to spawning; the skin is covered by dense slime.

Vladikov (1931) revealed for the first time that the paired fins of sterlet females are somewhat longer than those of males. Billard (2002) reported that the ventral part of the body in males of Adriatic (*A. naccarii*), Siberian (*A. baerii*),

Russian (*A. gueldenstaedtii*) and beluga (*H. huso*) sturgeons is darker than in females. Scutes in mature female white sturgeon (*A. transmontanus*) became soft due to mineralization during vitellogenesis.

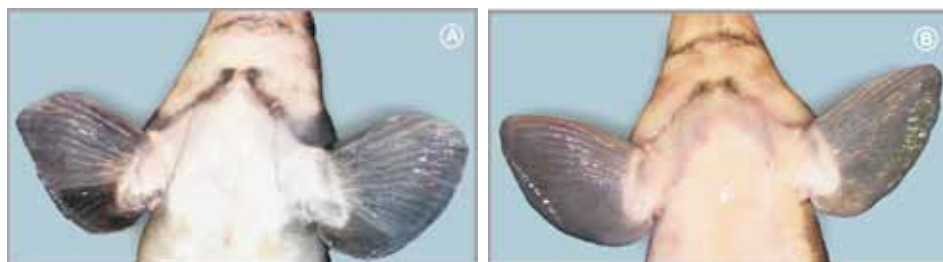
Comparative morphological analysis of adult specimens of North American sturgeons (white (*A. transmontanus*), Atlantic (*A. oxyrinchus*) and shortnose (*A. brevirostrum*)) allowed identification of a few external morphological sex differences (Vecsei *et al.*, 2003). For example, males have a urogenital opening in a shape of the letter “Y”, while that of the female looks like the letter “O” (Figure 49). The accuracy of sexual determination based on this sign was considerably higher in the case of live fish (82 percent) as compared to dead individuals (29 percent). As in the case of other fish species, attempts to identify external sex traits for sturgeons have been undertaken many times, but only partial success in the sexing of adult sturgeon has been achieved.

**Figure 49:** Differences in urogenital opening shape: **A** – male; **B** – female (Vecsei *et al.*, 2003).



The sexual dimorphism expressed by the shape and structure of the paired fins that is typical for many bony fishes has been revealed by Podushka (2008b) in farmed Amur sturgeon broodstock (*A. schrenkii*). As presented in Figure 50, shorter and more rounded pectoral fins are observed in mature females (Figure 50A), while the fins of males are of larger size and have an acute shape (Figure 50B). These differences, as Podushka reported, can be visible in farmed specimens of Amur sturgeon even from the dorsal side of fish seen in tanks. Similar differences have also been recorded in the structure of the pelvic fins of broodstock of this species. However, it is not evident if this sign depends on the sexual maturity of Amur sturgeon or if it can be also encountered in immature specimens. Similar differences have not been revealed for Amur sturgeon in the wild (Podushka, 2008b).

**Figure 50:** Shape of pectoral fins in farmed Amur sturgeon specimens: **A** – female; **B** – male (Podushka, 2008b).



The above mentioned advantages and shortcomings of the different sexing and gonadal maturity staging techniques should be considered in the course of planning and conducting autumn sturgeon assessment. At the same time, the perennial experience in sturgeon broodstock development and management has shown that the most effective related method is non-invasive express ultrasound diagnostics (Chebanov and Galich, 2009). The detailed description of this method is given in Chapter 14.

#### 4.2.4 Systematization of autumn assessment results

In the course of the autumn assessment, the mean length and weight, as well as the physiological state and fitness of the fish are evaluated in all age groups. On the basis of these assessment results, the fish are divided into different age and gonad maturity status groups (vitellogenic, mid- and post-vitellogenic stages of ovarian maturity). The fish are tagged by group or by individual tags and transferred to overwintering ponds. Fish selected for the next spawning season are kept separately during the overwintering period.

Throughout the assessment period, the following information should be constantly recorded in a special diary:

- name of the production facility;
- date of the record;
- species and age of the handled fish;
- numbers of the units (ponds, tanks) where the fish are held;
- purpose of the operation; and
- information on group fish tagging.

The resulting assessment documents are as follows: acts of fish relocation between different production units, acts of stocking and assessment of units (tanks, ponds, troughs).

## 4.3 OVERWINTERING OF BREEDERS

### 4.3.1 Overwintering conditions

Overwintering is the holding of fish at low temperature (2–6 °C) during two to three months. This is an obligatory element of the biotechnology for both wild sturgeon breeders captured in natural waterbodies during the period of autumn collection and for domesticated broodstock to complete the ovarian cycle. The stocking of overwintering ponds is performed at an average water temperature of not less than 8 °C.

The optimal temperature range of fish holding during overwintering is 4–5 °C. During overwintering, a short-term increase up to 7 °C or a decrease to 2 °C is permissible. The long-term holding of fish outside of this temperature range at starvation leads to their poor physiological state and as a result, to poor quality of the gametes.

### 4.3.2 Overwintering water unit requirements

A constant water exchange rate ensuring 80–100 percent oxygen saturation should be maintained in the overwintering ponds (Figure 51). An oxygen level of less than 60 percent is unacceptable.

**Figure 51:** Overwintering ponds for captive sturgeon broodstock.



Plastic and concrete tanks of volume > 40 m<sup>3</sup> and a depth > 1.5 m; “Kurinsky type” running water concrete ponds of 105 m length and 17 m width or ponds of 1 000–4 000 m<sup>2</sup> that can be divided by net walls into several sections for holding of different species and size-grades of fish are used (Figure 52). Constant water supply and full water exchange every 8–10 d should be used for overwintering.

**Figure 52:** Pond for overwintering and holding of broodstock with sections for separate holding.



#### 4.3.3 Stocking density of sturgeons intended for overwintering

The stocking density of broodstock (in ponds) for wintering is species dependent:

- Russian sturgeon: 20–25 kg/m<sup>3</sup>
- stellate sturgeon: 20 kg/m<sup>3</sup>
- beluga sturgeon: 25–30 kg/m<sup>3</sup>

Throughout the overwintering period, it is important to maintain optimal water circulation and a flow (exchange of water) in the water units. Control of water quality (levels of dissolved oxygen, iron oxides, ammonia, oxygen demand, pH, etc.) and reduction of suspended solids should be performed constantly. The fish behaviour should be also controlled if possible. The feeding of fish should be stopped during overwintering, as this has proved to be an important condition leading to effective completion of broodstock maturation.

Transition of the broodstock into and out of the overwintering regime is performed artificially during gamete processing (in autumn-winter and early spring, prior to the onset of the breeding season). It is essential to consider the following recommendations (Chebanov, 1996b):

- Transition to the overwintering temperature regime should be performed gradually, with thermal gradients of 1–2 °C and 2–3 °C per d for females and males, respectively.
- Fish with damaged skin should be exposed to decreased temperatures only after being held to recover at 8–10 °C.
- Transition to the spawning regime should be gradual, with a temperature gradient not higher than 1.5 °C per d for females and 2–3 °C per d for males, with periods of holding at constant temperature.



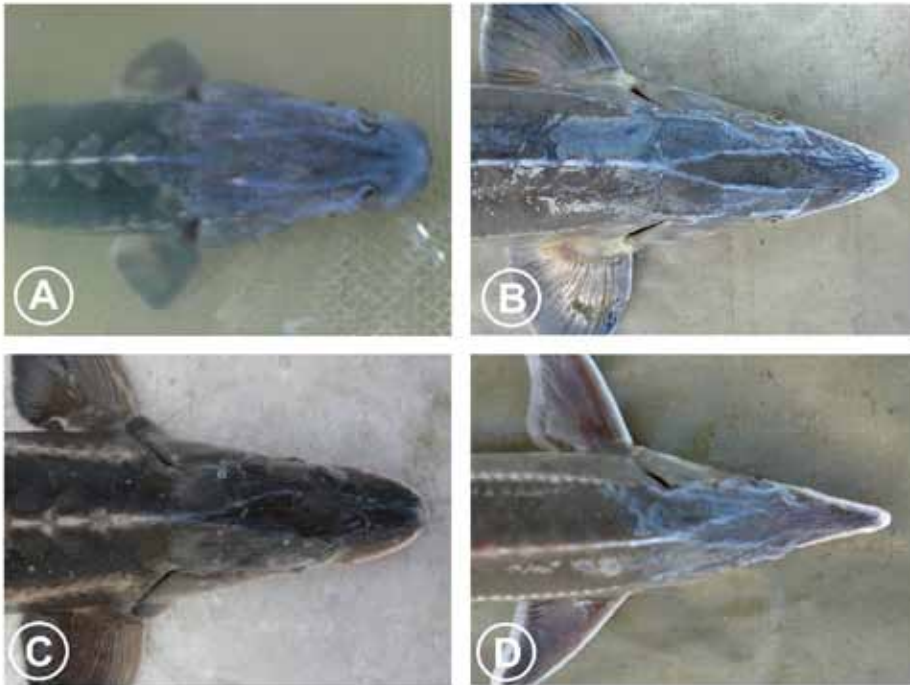
## 4.4 SPRING EVALUATION OF GONAD MATURITY STATUS

### 4.4.1 Selection of mature males

If the fish are held at ambient water temperature, spring assessment is conducted prior to reaching the spawning temperatures. Only broodstock with gonads at stage IV maturity are selected as candidates for breeding.

Ultrasound diagnostics has proved to be the most effective technique for selection of mature males. Mature males of some sturgeon species can be also selected on the basis of their external characteristics. Ripe males from hatchery-reared broodstock typically (excluding stellate and beluga sturgeons) have a distinct spawning “dress” (Figure 53).

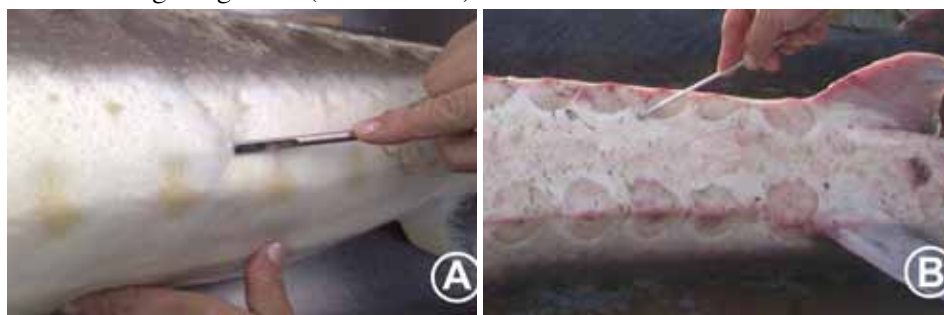
**Figure 53:** Spawning “dress” of different sturgeon species males: **A** – Russian sturgeon; **B** – Siberian sturgeon; **C** – ship sturgeon; **D** – sterlet.



### 4.4.2 Determination of spawnable females

At spring assessment of mature females, the biopsy technique is applied in order to identify readiness of females (selected in autumn) to spawn on the basis of PI values (Figure 54).

**Figure 54:** **A** – biopsy of Russian sturgeon gonads (lateral view); **B** – biopsy of Atlantic sturgeon gonads (ventral view).



In the course of assessment, females that have not reached stage IV gonad maturity and have oocyte resorption are culled or destined for fattening.

#### 4.4.2.1 Calculation of oocyte polarization index

Determination of oocyte polarization index (PI) requires exposure of extracted oocytes (not less than 10 from each female) to boiling physiological solution for 2 min or holding for 2 h in Serra's solution (mixture of 40 percent formalin, 96 percent ethanol and glacial acetic acid in the proportion 6:3:1). It is convenient to fix oocytes by vapour treatment in a common steamer for 3 min. The oocytes should be kept in physiological solution after fixation to avoid drying of the samples. Fixed oocytes are bisected along the axis of the two poles and examined using a binocular microscope equipped with an eyepiece micrometer (Figure 55).

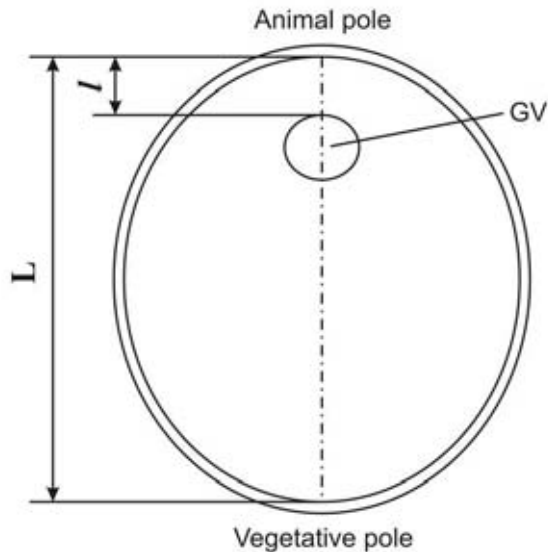
**Figure 55:** Dissected view of an oocyte using a binocular microscope.



The polarization index (PI) is a target characteristic that can be determined through oocyte sampling (Figure 55). The distance between the animal and vegetal poles (L), as well as between the animal pole and the outer edge of the nucleous germinal vesicle of the oocyte (l) is measured and the polarization index (ratio  $l/L$ ) is established (Figure 56). The oocyte membranes are not considered during the calculation.



**Figure 56:** Layout view of dissected oocyte in sturgeon. Key: GV – germinal vesicle; L – diameter of oocyte.



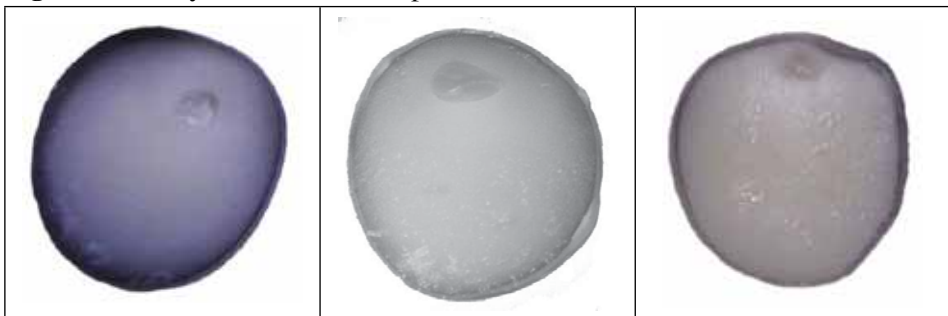
Measurement of the oocyte polarization index (PI) is calculated using the equation given below:

$$PI = l/L$$

where, **l** = distance from the germinal vesicle (outer edge) to the animal pole and **L** = distance from the animal pole to the vegetal pole (Figure 56).

Examples of oocytes with different PI values are presented in Figure 57.

**Figure 57:** Oocytes with different polarization index (PI) values.



It should be noted that presence of pigment in the oocyte yolk indicates the onset of resorption.

For research purposes, Van Eenennaam et al. (1996) used a dissecting microscope with a camera lucida and a digital image-analyzing tablet (Nikon

MicroPlan II) for PI determination with an accuracy of 0.01 mm. Rodina (2006) also used a binocular microscope (Zeiss STEMI 2000-C) coupled with an Olympus MI2000 adapter with a digital camera (Olympus Camedia C2000 ZOOM) that was connected to a video monitor. For good visualization, the cross-sections of oocytes were observed submerged in distilled water. To provide accurate determination of the nuclear position via the digital image of the oocyte, Olympus Microimage v. 4.0 software was used for the 2D-image analysis. This digital equipment allows a large number of oocyte samples to be processed with high accuracy.

#### 4.4.2.2 Segregation of females and selection of potential spawners

In order to optimize broodstock spawning management, females can be segregated into a few groups based on the oocyte polarization index (Table 9).

**Table 9:** Female grouping by oocyte polarization index (PI) and usage recommendations.

No	PI	Grup	Kullanım tavsiyeleri
I	$PI < 0.05$	Overripe	Transferred to fattening
II	$0.05 \leq PI < 0.10$	Ripe 1 (hormonal response)	Immediate hormonal stimulation at reaching spawning temperature
III	$0.10 \leq PI \leq 0.12$	Ripe 2	Upon reaching of spawning temperatures, may be held for 2–3 d; in the case of anadromous species, GnRHa stimulation is recommended
IV	$0.12 < PI \leq 0.15$	Near to spawn	Injection administrated after 7–14 d holding at spawning temperature
V	$0.15 < PI \leq 0.18$	Spawnable	20–40 d holding at spawning temperature prior to injection
VI	$0.18 < PI$	Immature	Separated for fattening

After the broodstock grouping, the schedule of further hatchery activities should be developed. Females from groups II and III may be used afterwards without recurrent biopsy. The PI in mature oocytes of females from groups IV–V should be re-examined, depending on timing of their readiness to spawn. The fish from group V, with oocyte PI that has not changed after holding at spawning temperatures during 14–21 d, should be regarded as immature and intended for fattening.

#### 4.4.2.3 Application of duration of sturgeon oocyte maturation *in vitro* for ripe females selection – Germinal Vesicle Break Down Test

Goncharov (1981, 1993) considered oocyte maturation time (the time during which the nucleus or germinal vesicle will migrate towards the animal pole and undergo breakdown) *in vitro* in the presence of maturation-inducing steroids (or progesterone or its metabolites, progestines) as a more effective criterion for selection of spawnable females than PI.

Williot, Brun and Rooryck (1991) and Williot *et al.* (2002) stated that use of the PI alone would lead to a high degree of failure with induced spawning of the Siberian sturgeon (*A. baeri*). This procedure was described for the first time by Goncharov (1981). It has also been revealed that when oocyte maturation lasts longer than  $18 \tau_0$  ( $\tau_0$  is the duration of one mitotic cycle during synchronous cleavage division), the quality of eggs extracted after hormonal injection is usually poor.  $\tau_0$  at different incubation temperatures for Ponto-Caspian species can be calculated using the curves indicated in Dettlaff, Ginsburg and Schmalhausen (1993) (see Annex III). More recently, a new approach was proposed by Goncharov (1993) and Goncharov *et al.* (2009) for selection of spawnable females based on determination of the time of *in vitro* maturation of 50 percent of the oocytes in the presence of progesterone (T50). For wild-caught stellate sturgeon (*A. stellatus*) females and farmed females of *A. ruthenus*, this method allowed identification and removal from artificial reproduction of a group of fish that were not capable of producing mature high quality eggs in this state and under standard conditions of hormonal stimulation.

This method was modified by Conte *et al.* (1988) and by Van Eenennaam, Bruch and Kroll (2001) for white sturgeon and by Williot, Brun, & Rooryck (1991) for Siberian sturgeon, and may be summarized as the following protocol of oocyte maturation competence *in vitro* assay:

1. A stock solution of 10 mg progesterone (4-pregnene-3, 20-dione) dissolved in 10 ml of 96 percent ethyl alcohol should be prepared. The stock solution may be preserved at a temperature of 16 °C in a tightly closed vessel.
2. Four Petri dishes should be set up for each female (two controls and two containing progesterone). The necessary amount of stock solution (for a final progesterone concentration of 5  $\mu\text{g/ml}$  in the solution in which oocytes are to be incubated) – 75  $\mu\text{g}$  (0.075 ml), should be added with a micropipet or 1 cc syringe to the bottom of the dry dish. After complete evaporation of the ethanol, 15 ml of Ringer solution modified for cold-blooded animals (6.5 g NaCl, 250 mg KCl, 300 mg CaCl<sub>2</sub> and 2 g NaHCO<sub>3</sub> per liter of distilled water) (Goncharov, 1981) should be added to each of the progesterone- labeled Petri dishes. The control dishes should receive the same quantity (75  $\mu\text{l}$ ) of the carrier (96 percent ethanol) used to dissolve the progesterone. To avoid any cross- contamination, separate syringes should be used for progesterone and ethanol (control dishes), and if a micropipette is used, the tip should be changed. The Petri dishes are then gently swirled to mix the solutions.
3. Fifteen oocytes removed from the female should be placed into a 20 ml wide beaker using a clean (unused) disposable plastic pipette. Follicles should be completely rinsed out with a few portions of Ringer solution. Then pipette into the beaker about 5 ml of Ringer from the Petri dish that the oocytes will go into. Gently swirl the beaker and pour the oocytes and

medium back into that Petri dish (this is important for maintaining the correct volume of Ringer solution in each Petri dish).

4. The time should be recorded and the oocytes are then incubated for 18 h.
5. Note that some authors (Doroshov et al., 1983; Conte *et al.*, 1988; Parauka, 1993; Mohler, 2003) recommend 24 h as the optimal time for oocyte incubation (at 15–16 °C) for breeding of North American sturgeons, while Van Eenennaam, Bruch and Kroll (2001) recommend 16 h (at 16 + 0.5 °C) and Mims *et al.* (2002) recommend 16 h (at 23 °C).
6. After completion of incubation, follicles are fixed by boiling or held in Serra's solution (Section 4.4.2.1). The follicles are immediately cooled by placing the beakers directly on crushed ice for 30 min. As indicated in Van Eenennaam, Bruch and Kroll (2001), very mature females usually have soft oocytes, even after chilling, but they become firmer and easier subjected to cutting after storage in buffered formalin for 24 h.
7. At this time, the oocytes can be cut along the animal-vegetal axis (refer to PI index determination above) with a razor blade and then evaluated. The presence or absence of the germinal vesicle may be observed by focusing a light beam on the section surface. Germinal vesicle breakdown (GVBD) or intact nucleous for each oocyte should be recorded.
8. A female with oocytes that show 100 percent response in the progesterone and some response in the controls should spawn within 1 week. A 100 percent response in the progesterone and no response in the controls indicate that this female should probably spawn in about 2 weeks. Females in which 90–100 percent of oocytes exhibit GVBD should be resampled in approximately 3–4 weeks. As Van Eenennaam, Bruch and Kroll (2001) noted, the estimates assume that the females are being held at approximately 13–15 °C. At warmer temperatures, these time periods should be reduced, while at colder temperatures they may be slightly extended. Females with less than 80 percent response are considered to be questionable candidates for spawning.

It should be noted that different incubation media have been tested or used by Williot, 1997. Some of these should be avoided (i.e. those using Ringer solution), because they are incomplete from the point of view of their components and are very unstable with regard to pH, which might lead to abnormal results (e.g. for Siberian sturgeon). It is strongly advised to use a medium that reproduces the blood characteristics of Siberian sturgeon (so called SIS medium), the formula for which is given below (Table 10).

**Table 10:** Composition of SIS medium for incubation of ovarian follicles (Williot, 1997).

Component and/or characteristic	Millimoles/liter	Weight (mg)
CaCl <sub>2</sub> , 2 H <sub>2</sub> O	1.95	287
MgCl <sub>2</sub> , 6 H <sub>2</sub> O	0.85	172
KCl	2.7	201
Na <sub>2</sub> SO <sub>4</sub>	0.7	99
NaCl	127.5	7420
Hepes (Biological buffer)	20	4760
pH should be brought to 7.8–8 (with NaOH)		
Osmotic pressure should be about 270 mOsm/liter		

#### 4.5 DETERMINATION OF PRESPAWN HOLDING REGIMES FOR BROODSTOCK

##### 4.5.1 Optimal prespawn holding of broodstock depending on oocyte polarization index

The index of oocyte polarization (PI) values recorded during biopsy gonad examination is the basic criterion routinely used at sturgeon hatcheries for proper female prespawn holding regime selection (Table 11). For example, females with  $PI < 0.09$  may ovulate eggs at spawning temperatures after hormonal administration without prespawn holding. Duration of prior-to-spawn holding of other female groups (Table 11) is determined on the basis of the sum of effective temperatures of water (expressed in degree-days). Prior to spawning, holding should be performed at spawning temperatures without any short-term water temperature increase above the optimal value. In this instance the less mature fish should be held at lower spawning temperatures and the gradient of temperature increase should be lower prior the hormonal stimulation. Violation of this requirement causes desynchronization in oocyte maturation resulting in poor hatchery quality of eggs.

Duration of prior-to-spawn holding of other female groups (Table 11) is determined on the basis of the sum of effective temperatures of water (expressed in degree-days).

**Table 11:** Regimes of prespawn holding of broodstock based on the oocyte polarization index (PI).

PI	Sum of effective temperatures, °d	Duration of holding at different temperatures, d			
		8–10 °C	12–13 °C	14–16 °C	16–18 °C
0.10	30–50	5–8	3–6	2–5	1–3
0.11	60–70	7–10	4–7	3–6	2–4
0.12	90–100	9–12	5–9	4–7	3–5
0.13	120–150	10–14	9–12	7–8	5–7
0.14	170–200	12–15	10–14	9–12	7–10
0.15	210–250	15–18	12–17	10–14	9–12
0.16	260–300	18–22	15–20	12–16	Not recommended except for stellate sturgeon
0.17	350–400	21–25	17–22	14–21	–
0.18	410–500	30–40	25–30	20–25	–

In the case where the period of holding of females at spawning temperatures differs slightly from that indicated in Table 11, it is expedient to use triiodthyronine (T-3) before hormonal injection to improve ovulatory success (Dettlaff, Ginsburg and Schmalhausen, 1993).

The primary requirement for the prespawn holding of males is the preservation of their reproductive quality. Typically, males are spawnable even after short-term exposure to spawning temperatures; therefore, the most effective way to maintain their reproductive quality is to hold them at low temperatures. In the case of extended exposure of males to spawning temperature, they tend to become overripe (especially males of beluga, stellate and sterlet sturgeons); as well, problems with sperm may arise while working with the last lots of females.

#### **4.5.2 Assessment of broodstock spawnability on the basis of physiological and biochemical indices and regimes of prespawn holding**

Note that an oocyte PI is not the only characteristic that can be used to determine proper prespawn holding timing. In the longstanding practice of Azov and Caspian seas sturgeon hatcheries, the readiness of females to spawn was evaluated on the basis of a study of their physiological status. This is most urgent when working with wild breeders (Badenko *et al.*, 1984; Chebanov *et al.*, 1991) captured during various periods of the spawning run on different reaches of the spawning route. The considerable variability of reproductive indices, which requires individual evaluation, is typical for such fish. Study of the physiological status of breeders allows identification of spawnability using hematological techniques, as well as assessment of adaptive function of lipid metabolism at the final stages of the reproductive cycle.

For identification of breeders (Chebanov *et al.*, 1991; Chebanov and Savelyeva, 1999), the *in vivo* examination of biochemical blood serum parameters allows correlation with the level of fat deposition in the musculature and reflects the potential reproductive ability under hatchery conditions.

Sturgeon females with a high level of oocyte resorption and gonads at IV incomplete maturity stage typically migrate at the onset of the spawning run. Such females respond positively to hormonal injections only after holding at spawning temperatures (up to 200 °d). Riper females with comparatively larger eggs and higher levels of protein in the oocytes migrate in the middle of the spawning run. In this case, hormonal injections should be administered after holding for short duration. Therefore, earlier, as a rule, biopsy examination was not applied for determination of spawnability of breeders captured during the period of spawning run. The duration of prior-to-spawn holding of these spawners at hatcheries was determined on the basis of dates of the capture in the wild. (Table 12).

**Table 12:** Recommendation on duration of prespawn holding of broodstock captured during spring spawning run.

Species, spawning run period	Duration of holding	
	°d	d
Azov Sea Basin		
Russian sturgeon		
Onset of spawning run, captured in sea	100–200	5–15
Mass spawning run, harvesting in sea	40–120	2–10
Stellate sturgeon		
Onset of spawning run, harvesting in sea	250–400	20–35
Mass spawning run, harvesting in sea	200–300	10–20
Harvesting in river, May	180–220	10–15

The current protocols for *in vivo* blood sampling intended for individual analysis of the physiological status of fish are noninvasive and comply with modern industrial standards of sturgeon artificial reproduction. These protocols allow the whole hatchery process to be accomplished on a differential basis, taking into account the initial physiological state of the brood fish. For selection of individual females to be used for hatchery production of eggs after hormonal stimulation, the following indices (Table 13) may be applied to identify fish with complete trophoplasmatic growth of oocytes (IV complete stage), immature fish (IV incomplete stage) or skinny fish (after warm winters or late spawning season) with early degeneration of gametes (Badenko *et al.*, 1984).

**Table 13:** Physiological indices of wild breeders (Badenko *et al.*, 1984).

Indeks	Status of gonad, oocyte maturation stage		
	IV incomplete	IV complete	Skinny
Stellate sturgeon			
Blood serum protein, g %	> 5	3–4	< 2
General lipid, mg %	> 2 000	500–2 000	< 500
Hemoglobin, mg %	> 14	8–13	< 8
Cholesterol, mg %	> 250	100–250	< 100
Muscular fat , % <sup>1</sup>	> 25	14–24	< 14
Egg fertilization rate, %	27–48	86–93	will not reach maturation
Russian sturgeon			
Blood serum protein g %	> 4.5	3–4.5	< 2
General lipids , mg %	> 1 500	500–1 500	< 500
Hemoglobin, mg %	> 14	8–13	< 8
Cholesterol, mg %	> 200	100–200	< 100
Muscular fat, %	> 20	8–15	< 7
Egg fertilization rate, %	50–70	82–90	will not reach maturation

<sup>1</sup>Fat content in muscles correlates with biochemical characteristics of blood and is determined by calculation.

It should be mentioned that the mean values of protein and lipid metabolism indices of wild females (Table 13) during the final phases of the reproductive cycle confirm normal development of gonadogenesis. Poststimulation biochemical characteristics of blood exhibit a 12–25 percent decrease (from the initial level) in hatchery productive females and a 50–70 percent decrease at transition of gonad to flow condition.

Indices considerably higher than the mentioned mean values are typical for immature specimens, the duration of prespawning holding of which should be prolonged. Lower diagnostic characters correspond to skinny fish, hatchery utilization of which is not reasonable. In cases where such fish are to be used for reproduction (e.g. rare species, lack of spawners), the length of their prespawning holding should be maximally curtailed, and hormonal stimulation should be performed using a lower (two-fold) preparation dose.

#### 4.5.3 Prespawning correction of functional state of broodstock

The abrupt supercooling or vice versa, the prolonged (as compared with optimal) holding of broodstock at spawning temperatures suppresses their response ability to hormonal administration and hampers maturation. To restore reactivity of follicular epithelial cells (in the case of females being held at spawning temperatures), it is recommended to apply intramuscular injections of



triiodothyronin (T-3) at a dosage of 20 mg per kg of weight once a day (over a period of 2–4 d) in the course of prespawning female holding. Note that triiodothyronin administrations are not effective in the case of prolonged exposure to unfavourable conditions and inconvertible changes (atresia) of oocytes (Dettlaff, Ginsburg and Schmalhausen, 1993).

The administration of vitamins C (ascorbic acid) and E ( $\alpha$ -tocopherol) during the period of prespawning holding of broodstock was suggested by Sorokina (2004) to enhance reproductive performance, increase fecundity and accelerate the synchronization of wild female oocyte maturation and hence reach higher egg fertility rates. This technique involves the use of pharmaceuticals as follows: 10 percent solution of ascorbic acid (100 mg/ml) and 30 percent  $\alpha$ -tocopherol acetate (300 mg/ml). The best results were recorded for a two-week course (4 injections per d) of vitamins C and E, single administration, 10 mg and 15 mg per kg of female weight, respectively.

Matishov, Ponomarev and Ponomareva (2007) recommended to perform cyanocobalamin (vitamin B12) injections at 500  $\mu$ kg/ml concentration (or 50  $\mu$ kg per kg of fish weight) the day following administration of vitamins E and C. The cyanocobalamin enhances protective functions and response to stressors in female sturgeon, along with improvement of hatchery characteristics (e.g. egg fertility rate and survival of progeny).

## 4.6 HORMONAL INDUCTION OF SPAWNING

### 4.6.1 General recommendations on hormonal induction

Preparation for hormonal stimulation should be started at temperatures close to ranges optimal for egg incubation, which vary for different sturgeons (, 14).

**Table 14:** Optimal temperature ranges (T, °C) for sturgeon egg incubation.

Species	Russian sturgeon	Beluga sturgeon	Stellate sturgeon	Sterlet	Ship sturgeon
T °C	14–18	9–14	17–21	10–15	14–18

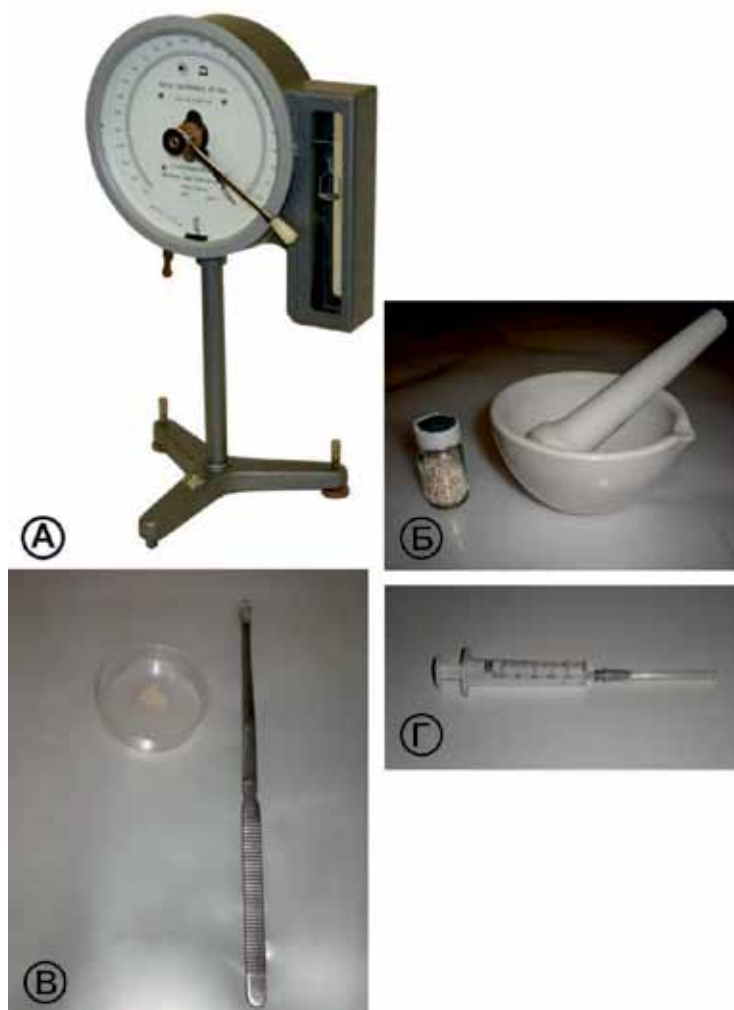
Among gonadotropins, the most frequently used preparations that can be applied for stimulation of spawning in sturgeon broodstock are:

- acetone-dried sturgeon pituitary (SP);
- acetone-dried common carp pituitary (CCP);
- sturgeon pituitary glycerol preparation (PGP); and
- GnRH $\alpha$  – superactive synthetic analogue of mammalian gonadotropin-releasing hormone (des Gly<sup>10</sup>[D-Ala<sup>6</sup>] GnRH ethylamide).

#### 4.6.2 General recommendations on injection

An acetone-dried pituitary is ground to a powder using a pestle in a dry, clean porcelain mortar (Figure 58). The necessary dose is weighed separately for females and males on a torsion balance. Physiological solution (6.5 g of chemically pure common salt per 1 liter of distilled water) or Ringer solution for poikilothermic animals is added to a weighted dose and carefully mixed. The amount of pituitary is determined in relation to the water temperature, weight of fish, species, sex and preparation activity (frog unit).

**Figure 58:** Equipment and materials for pituitary suspension preparation: **A** – torsion precision balance; **B** – mortar and pestle for pituitary grinding; **C** – ground dried pituitary; **D** – syringe for injections.



Medical syringes may be used for injections. Syringe length (2.5–3.8 cm) and volume (1–5 ml) should be selected depending on the fish size, preparation

dose and type. If acetone-dried pituitary is administered, it is good practice to use needles of a larger diameter (for intravenous injections). At SP and CCP arrangement, it is essential that the volume of ready preparation for individuals of 5 kg weight should be 2 ml or less; 1 ml of solution is to be added to the preparation for each extra 5 kg of individual weight. An intramuscular injection should be administered in the dorsal muscles between the dorsal and lateral scutes at the level of the third to fifth dorsal scutes (Figure 59). Care should be taken while performing the injection in order to prevent hormone expulsion associated with the tough muscles of the fish. The preparation should not be injected subcutaneously. Very deep needle insertion into the body is dangerous.

**Figure 59:** GnRH $\alpha$  injection administration: **A** – male stellate sturgeon; **B** – female Russian sturgeon.



If the dose intended for administration is large, it should be divided into two portions and injected into different parts of the dorsal musculature. The preparation and filling of syringes with suspension of acetone-dried pituitary should be carried out 30–40 min prior to injections. Distilled water should be used for dilution of sturgeon pituitary extract. It also should be noted that in past years, sturgeon pituitary extract has rarely been applied due to the end of pituitary production from mature sturgeon resulting from bans on fishing.

#### 4.6.3 Pituitary preparation administration

At induced spawning of female broodstock, gradual injections are preferred. The total dose of preparation depends upon the water temperature and fish weight (Table 15), while the percentage of primer dose depends upon the stage of oocyte maturation, which is associated with the polarization index value (Table 16). It should be taken into account that skinny fish are more sensitive to pituitary injections; therefore, the dosage of preparation is to be reduced.

Pituitary overdose causes ending of embryonic development at late stages of embryogenesis. As a consequence the prelarvae will have a weak, soft yolk sac and die within 1–5 d after hatching.

**Table 15:** Relationship between pituitary dose and water temperature.

Water temperature, °C	Sturgeon pituitary, mg/kg <sup>1</sup>	Common carp pituitary, mg/kg	Sturgeon glycerine pituitary extract, frog unit/kg	Index in skinny fish	Time interval between injections, h
Russian sturgeon					
10–12	2.5	4.0	7.0	0.95	18
12–14	2.0	3.0	5.0	0.90	15
14–18	1.5	2.5	4.0	0.85	12
above 18	1.0	1.5	2.5	0.80	9
Stellate sturgeon					
13–16	2.5	4.0	7.0	0.95	14
16–19	2.0	3.0	5.0	0.90	12
19–21	1.5	2.5	4.0	0.85	9
above 21	1.0	1.5	2.5	0.80	7
Beluga sturgeon					
9–12	2.5	4.0	7.0	0.95	16
12–15	2.0	3.0	5.0	0.90	12
15–16	1.5	2.5	4.0	0.85	12
above 16	1.0	1.5	2.5	0.80	10
Sterlet					
10–12	4.0	6.0	10.0	0.95	14
12–14	3.5	5.0	8.0	0.90	12
14–16	3.0	4.5	7.0	0.85	10
above 16	2.5	3.5	6.0	0.80	8

<sup>1</sup>At use of pituitary of standard activity (3.3 frog unit/mg).

**Table 16:** Relation between primary injection of pituitary dose and oocyte polarization index (PI).

Polarization index	0.04	0.05	0.06	0.07	0.08	0.09	0.10	0.11	0.12	0.13
Primary injection, % of total dose	10	13	15	18	20	23	25	25	28	30

Traditionally, males of all species should be subjected to a single injection scheme before initiating injection of females. The dosage of hormonal preparation for males is half that used for females. Trials with Siberian sturgeon have revealed (Williot, 2002; Williot *et al.*, 2009) that peak spermatozoa activity is observed 36 h post-injection. Therefore, it is recommended to inject males 2–4 h prior to female administration. Tan'kin (1979), who described the possibilities of sperm

collection during the four days after single hormonal injection for sterlet, noted that multiply milt stripping has a positive effect on the motility of spermatozoa in the successive batches of milt.

Due to the difficulty of providing a reliable evaluation of the quality of males using the ultrasound technique, it is recommended (Trenkler and Gruslova, 2006) to start injection of males 1.5–2 d earlier than that of females, especially for beluga and first lots of Russian sturgeon. In this situation, the collected sperm should be preserved by refrigeration (Section 5.1.4).

Gruslova and Trenkler (2001) also showed the possibility of repeated sperm collection by means of injection of Russian sturgeon males that had produced a full quality of sperm (as GnRH $\alpha$  administration in this case is less effective, its dose should be increased 1.5–2 times) by pituitary preparation 3–4 d after the first injection. Note that this approach (excluding the case of a complete lack of males) might be recommended only for commercial sturgeon culture, but is not recommended for genetically sustainable programmes of hatchery stock enhancement (Chapter 11), due to the resulting decrease in effective population size. The repeated collection of sperm from beluga males during one spawning season is impossible.

#### **4.6.4 Recommendations on synthetic analogue of mammalian gonadotropin-releasing hormone (GnRH $\alpha$ , Surfagon) injection administration**

The essential factor of female maturation after GnRH $\alpha$  administration is the ability of the pituitary to secrete a sufficient quantity of gonadotropins into the blood as a result of hormonal induction (Goncharov, *et. al.* 1991). GnRH $\alpha$  administration can cause a negative response associated with secretion of its hormonal inhibitor dofamin in blood (Goncharov, 1998). The similar reaction of the endocrine system is frequently observed in potamodromous sturgeon species and forms (sterlet and Siberian sturgeon of the Lena population). Investigations of germinal vesicle movement (cortical reactions and egg division) have revealed that a high dosage of exogenous gonadotropin (pituitary injection) can cause ovulation even when cytoplasm maturation is not fully completed and does not establish maturation competence (Nocillado, Van Eenennaam and Doroshov, 1999).

GnRH $\alpha$  administration, as distinct from the pituitary preparations, does not damage oocytes even when exceeding 400 times dosage (Goncharov, 1998). It is very significant for beluga, *H. huso*, where the exact weight of large fish (more than 100 kg) is difficult to fix, that there are no negative reproductive consequences due to a hatchery-injected GnRH $\alpha$  overdose as compared to pituitary injections (Chebanov and Savelyeva 1996), where the effect is determined by the calculation for a dose of hormonal agents. The significant requisite of the successful preparation is following the optimal temperature regime with 2–3 °C temperature elevation after the first (primer) injection (Chebanov *et al.*, 1998; Chebanov and Savelyeva, 1999). GnRH $\alpha$  application does not stimulate fish maturation under conditions of temperature variation (especially sharp drop)

because it does not contain gonadotropin hormones and is intended for “soft” physiological stimulation of endocrine centers in fish and enables the appearance of endogenous gonadotropin that usually results in high hatchery quality of eggs.

Application of GnRHa shows low efficiency in case of ill, stressed or injured fish or at sharp variations in atmospheric pressure and/or disruptions of the hydrochemical regime.

GnRHa application is most efficient for hormonal induction of anadromous females (beluga, stellate and Russian sturgeons) and stimulation of sturgeon males of all species, for which a recommended minimal dose range is 1–2  $\mu\text{g}/\text{kg}$ . Preparations can be administrated as a single injection, partially or gradually (Table 17).

**Table 17:** Suggested GnRHa total dosage for induction of ovulation in sturgeon females (Chebanov, Galich and Chmyr, 2004).

Temperature, $^{\circ}\text{C}$	Time between injections, h	Injections		
		Primer, $\mu\text{g}/\text{kg}$	Resolving	
			PI<0.1 $\mu\text{g}/\text{kg}$	$0.1 \leq \text{I} < 0.13$ $\mu\text{g}/\text{kg}$
Russian sturgeon				
12–16	12	0.5	0.5	1.0
> 16	8	0.5	0.5	0.5
Beluga sturgeon				
12–15	12	0.3	1.0	1.0
15–18	9	0.3	1.0	1.0
Stellate sturgeon				
14–16	8	–	0.5	1.0
>16	6	–	0.5	0.5
>16 in spring season	6	–	1.0	1.0

In some cases, the following complex scheme involving the administration of two injections, a primer pituitary injection and a resolving GnRHa injection (1.0–1.5  $\mu\text{g}/\text{kg}$ ) is applied. Administration of GnRHa prior to pituitary injection is risky because injected exogenous gonadotropin will be “excessive” for spawners and can lead to follicular atresia.

In addition, during the past 15 years the use of traditional sturgeon pituitary injection for inducing maturation of sturgeon spawners in the Sea of Azov basin often led to a decreased quality of sturgeon gametes. A comparative analysis of the response of stellate sturgeon caught in the river and subjected to pituitary and GnRHa injections has confirmed that GnRHa injections negatively affect those “river” fish that are closer to the spawning state. GnRHa injections act as a catalyst for activation of mature fish pituitary (Chebanov and Savelyeva, 1999).



## Chapter 5

### Spawning and gamete processing

#### 5.1 OBTAINING MATURE GAMETES

##### 5.1.1 Monitoring broodstock maturation

The latency time of broodstock maturity depends on the temperature (Dettlaff, Ginsburg and Schmalhausen, 1993) (Table 18).

**Table 18:** The latency time of sturgeon female maturation at different temperatures (according to Dettlaff, Ginsburg and Schmalhausen, 1993), in hours after pituitary injection. **A** – time of first female examination; **B** – time after which it is impossible to obtain quality eggs. Bold underlined values (e.g. 22) indicate optimal spawning temperatures; bold values that are not underlined (e.g. 22) indicate extreme spawning temperatures.

Temperature, °C	Russian sturgeon		Beluga sturgeon		Stellate sturgeon		Sterlet		Siberian sturgeon	
	A	B	A	B	A	B	A	B	A	B
6	–	–	<b>85*</b>	<b>150</b>	–	–	<b>72</b>	<b>120</b>	–	–
7	–	–	70	125	–	–	<b>58</b>	<b>105</b>	–	–
8	–	–	60	95	–	–	48	80	–	–
9	–	–	50	90	–	–	40	68	<b>48</b>	<b>73</b>
10	<b>48</b>	<b>73</b>	<b>42*</b>	<b>78</b>	–	–	35	60	39	60
11	39	60	<b>35</b>	<b>67</b>	–	–	<b>30</b>	<b>52</b>	<b>34</b>	<b>51</b>
12	<b>34</b>	<b>51</b>	<b>30</b>	<b>56</b>	–	–	<b>25</b>	<b>45</b>	<b>32</b>	<b>45</b>
13	<b>30</b>	<b>45</b>	<b>27</b>	<b>50</b>	–	–	<b>22</b>	<b>40</b>	<b>27</b>	<b>45</b>
14	<b>27</b>	<b>40</b>	<b>24</b>	<b>44</b>	<b>28</b>	<b>50</b>	<b>20</b>	<b>36</b>	<b>24</b>	<b>40</b>
15	<b>24</b>	<b>36</b>	<b>21</b>	<b>40</b>	24	40	<b>18</b>	<b>33</b>	<b>22</b>	<b>36</b>
16	<b>22</b>	<b>33</b>	<b>19</b>	<b>35</b>	<b>22</b>	<b>36</b>	<b>16</b>	<b>28</b>	<b>20</b>	<b>33</b>
17	<b>21</b>	<b>31</b>	17	32	<b>20</b>	<b>32</b>	<b>14</b>	<b>26</b>	<b>18</b>	<b>28</b>
18	<b>19</b>	<b>28</b>	<b>16</b>	<b>30</b>	<b>18</b>	<b>29</b>	13	24	<b>16</b>	<b>26</b>
19	<b>17</b>	<b>27</b>	<b>14</b>	<b>30</b>	<b>16</b>	<b>27</b>	<b>12</b>	<b>22</b>	15	24
20	16	26	–	–	<b>15</b>	<b>25</b>	<b>11</b>	<b>21</b>	<b>14</b>	<b>22</b>
21	16	25	–	–	<b>14</b>	<b>23</b>	–	–	<b>13</b>	<b>21</b>
22	15	24	–	–	<b>13</b>	<b>22</b>	–	–	–	–
23	<b>15</b>	<b>24</b>	–	–	12	21	–	–	–	–
24	<b>15</b>	<b>23</b>	–	–	12	20	–	–	–	–
25	–	–	–	–	<b>11</b>	<b>19</b>	–	–	–	–
26	–	–	–	–	<b>11</b>	<b>19</b>	–	–	–	–



If a single GnRHa injection has been administered to females, the calculation should be performed considering a 5–6 h delay in maturation as compared with the latency time after pituitary preparation.

The examination of fish should be initiated by taking into account the time of first maturity of females. Small fish are bent in a lateral direction and the ovulation rate is assessed by the appearance of ovarian coelomic fluid or eggs (Figure 60):

- fish exhibiting many eggs are prepared for the extraction procedure (the interval between examination and stripping for such fish should be less than 30–40 min; for instance in stellate sturgeon, exceeding this time limit can lead to full resorption of eggs);
- fish producing coelomic fluid or single eggs should be re-examined in 1 h; and
- fish without evident signs of maturity are examined in 2–3 h.

**Figure 60:** Evaluation of ovulation rate in mature sturgeon female.



From time to time, large females are palpated and the most mature individuals are identified on the basis of the soft belly. To evaluate the ovulation rate of large fish, it is recommended to use the ultrasound technique (Chapter 14), thus avoiding possible stressors (Chebanov and Galich, 2009), keeping the fish in the water. Fish that do not exhibit signs of ovulation even after the deadline should be culled or could be used for fattening purposes (aquaculture). In order to diminish the effects of stress associated with examination, it is recommended that females be separated into a few groups according to their capability to ovulate and kept in different tanks. To avoid spontaneous release of eggs, it is wise to hold only one

or two large specimens in a tank. Collection of gametes starts when first females exhibit clear maturation signs – strong ovarian fluid with single eggs. In the case of occurrence of fish ready for immediate egg collection, the sperm should be collected after obtaining the eggs.

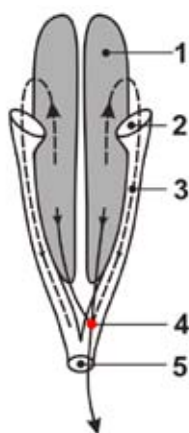
The techniques for the examination of spawners are, in theory, applicable to all sturgeons, but the species-specific peculiarities of their application depend on fish size, the type of tank in which females are kept after injection and the species involved. Upon examination of females, it is necessary to reduce to a minimum the effects of stressors (i.e. noise and abrupt changes in illumination). The installation of fine-mesh screens on the discharge pipes from the pools allows the ovulated eggs to be caught, optimizing control over the maturation of females. Should the need for night-time illumination arise, to decrease the effects of stress, red light of 680 nm wave length, which is not perceptible to sturgeons, should be used (Sbikin, 1973). To optimize control of ovulation, it is recommended to equip tanks with bottom plates having sieves of small hole size. To facilitate handling of females during examination, carrying to the place of egg selection and during the selection itself, one should have special equipment and materials (e.g. tables, wheelbarrow, tube-style nets, etc.).

### 5.1.2 Extraction of ovulated eggs

The lack of breeders collected from the wild and the labour intensiveness of broodstock development operations lead to the need to collect eggs from live female sturgeon. However, to date there exist few methods for nonlethal collection of ovulated eggs.

#### 5.1.2.1 Podushka's minimal invasive technique of oviduct incision

The most effectively used technique, which has been successfully applied since 1986 (Podushka, 1986, 1999) (Figure 61) and has proved to be less lethal for fish, involves oviduct incision with posterior manual stripping.



**Figure 61:** Schematic drawing illustrating the relative location of the ovaries and oviducts in the body of sturgeon (modified from Podushka, 1999): **1** – ovary; **2** - oviduct funnel; **3** – oviduct; **4** – incision location; **5** – genital opening. The dotted line represents the pathway of ovulated eggs at natural spawning; the solid line, at stripping after oviduct incision).

When using this method, the female should be placed on a sloping table designed according to fish size, with the head upwards and the tail not hanging down. To open the abdominal cavity, the scalpel with its cutting edge upward (blade width should be less than the diameter of the genital opening) is inserted into the genital opening and an incision (1–2 cm in length) is made at the caudal area of the oviduct wall in one or both oviducts, thus making an opening into the body cavity (Figure 62).

**Figure 62:** Oviduct incision in farmed stellate sturgeon (South Branch Federal Center of Selection and Genetics for Aquaculture, Krasnodar, Russia).



Eggs are manually stripped through the incision by gentle massaging of the posterior abdominal area (Figure 63). The handle of the scalpel or a medical spatula can help to keep the incision open.

**Figure 63:** Stripping of stellate sturgeon eggs after oviduct incision (South Branch Federal Center of Selection and Genetics for Aquaculture, Krasnodar, Russia).



Stripping is conducted while eggs are freely flowing from the body cavity (typically from 2 to 20 min depending on female size). One hour after the first

stripping, during which 80–90 percent of the eggs are collected, the second stripping procedure, which does not involve additional oviduct incision, is performed. In the case of larger and highly productive females, a third stripping sometimes may be applied (Podushka, 1999). After the egg collection, suturing and additional treatment are not needed. In some cases, abdominal pores in females can be so large that all ovulated eggs can be stripped in one or two portions without incision and additional efforts, in a way similar to applying Podushka's method. A danger to be avoided is the accidental incision of a kidney or the blood vessels of the rectum; however, this potential damage is not associated with an increased risk of spawner mortality. In addition, unskilled operators can injure the spawner's rectum with the scalpel. In this case, ovulated eggs will pass out through the anal vent. Usually the scalpel wound heals quickly, but very rarely an inflammation may take place. Usually this damage is not risky to the spawner's life.

This minimally invasive microsurgery method has been used for more than 20 years, with many females of different sturgeon species being stripped more than seven times.

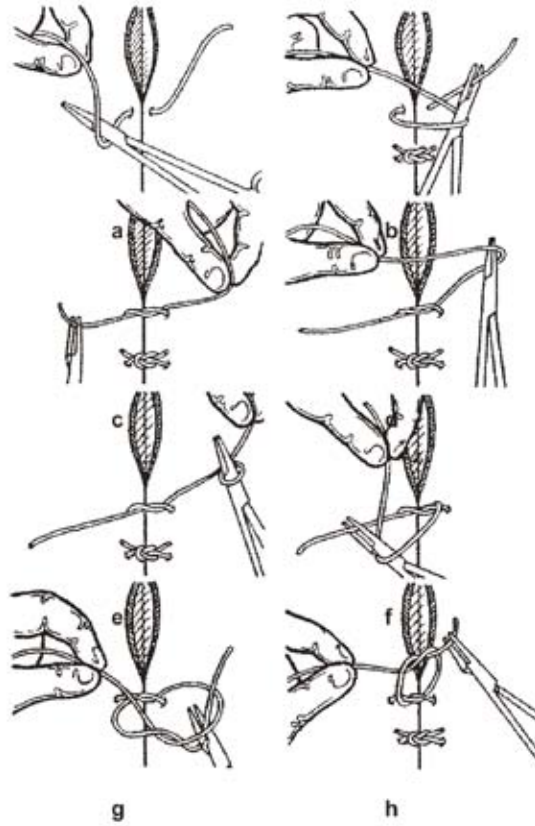
#### **5.1.2.2 Laparotomy**

In case of even larger fish (above 130 kg), it is wise to use the open laparotomy technique (Burtsev, 1969; Doroshov *et al.*, 1983; Conte *et al.*, 1988; Mohler, 2003). Under general anaesthesia, a longitudinal incision (8–14 cm in length, depending on the female's size) is made by scalpel in the rear third of the abdomen, somewhat laterally (1.5–2 cm from the midline), through which the ovulated eggs are extracted.

After extraction of eggs, the incision is sewn up by a silk or kapron-coated thread. Suturing of the incision is the most difficult stage of the surgery technique, due to the dermal denticles in the sturgeon's skin (Figure 64).

The area of the post-operative wound must be treated with an antiseptic (Figure 65). During the subsequent one to two weeks, the females are monitored. Survival rates of females subjected to laparotomy amount to 90 and 85 percent for beluga and Russian sturgeons, respectively (Shevchenko, Popova and Piskunova, 2004).

**Figure 64:** Example of postsurgery suturing (taken from Summerfelt and Smith, 1990 – as given in Van Eenennaam, Bruch and Kroll, 2001).



**Figure 65:** Postsurgery suturing.



A number of experimental modifications to the laparotomy technique have been suggested for extraction of ovulated sturgeon eggs; for instance, applying small (2.5 cm) angle incisions, using artificial ovarian fluid and even inserting a fistula (portal) for repeatedly sampling ovarian maturation to avoid stressing broodstock via repeated egg collection (Wakeford, 2001).

#### **5.1.2.3 Manual stripping technique**

Arlati *et al.* (1988) applied a technique for stripping of ovulated eggs via the female's oviducts by means of multiple extraction in small portions over an extended period (6–12 h) without operative intervention. Typically, up to one liter of eggs can be extracted during the first strippings. The disadvantages of this method are its long duration, labour-intensiveness, lower quality of eggs in the last portions and incomplete extraction. This approach is ineffective for producing eggs from large industrial lots of females.

#### **5.1.2.4 Stroking biotechnique**

An improved noninvasive method of ovulated egg extraction by stroking was proposed by Bruch, Dick and Choudhury (2001). It consists of the constant (“two-stage”) change in direction of stroking of the abdominal cavity, the first motion being from the funnel of the oviducts (Muellerian ducts) to the genital opening, and the second one being along the entire abdominal cavity from the anal fins to the funnel of the oviducts. According to Bruch, Dick and Choudhury (2001), during rapid stroking (20 strokes per 15 s), pressure is applied along the lateral parts of the fish (opposite the oviducts) during the anterior to posterior stroke, and by the thumbs during the posterior to anterior stroke to empty and repeatedly fill the ducts with eggs and to force them out of the genital pore.

It should be emphasized that contamination of eggs by blood, water and mucus during egg extraction should be excluded to avoid poor egg quality. Jolting and direct sun light should also be avoided.

#### **5.1.3 Sedation of broodstock**

The application of anaesthesia is advisable during gamete extraction from large fish weighing more than 40 kg (e.g. beluga, white sturgeon, kaluga (*Huso daricus*), Chinese sturgeon (*Acipenser sinensis*)). The anesthetics used in sturgeon farming are as follows:

- tricaine methanesulphonate (MS-222) 40 mg/liter (baths): In soft (weakly alkaline) water (< 30 mg/liter CaCO<sub>3</sub>), it is necessary to increase pH by addition of NaHCO<sub>3</sub>. For example, when using an MS-222 solution at 100 mg/liter, 200–250 mg of sodium bicarbonate needs to be added;
- oil of cloves (eugenol 4-allyl-2-methoxyphenol (C<sub>10</sub>H<sub>12</sub>O<sub>2</sub>)); 70–90 percent, acetoeugenol up to 17 percent and kariofilen at 5–12 percent (Kouřil *et al.*, 2004). Clove oil at a concentration of 0.1 mg/liter has also

been effectively used as an anaesthesia for various sturgeon species and their hybrids (Podushka and Chebanov, 2007). In the case of 5 percent eugenol solution (95 percent ethyl alcohol) application – baths at a water temperature of 15 °C and 200 mg/liter are applied, while at higher temperatures (above 20 °C) – 100 mg/liter is used (Moller, 2003). Other authors (Van Eenennaam, Bruch and Kroll, 2001) have tried concentrations of 17–60 mg/liter when using clove oil. Response to clove oil application is temperature dependent. At higher temperatures, anaesthesia and the process of recovery occur swiftly. Note that the process of spawner recovery is five to six times longer than in the use of MS-222.

For irrigation of the gills, a 0.1 percent alcoholic solution of etomidate (Propiscin) may be used (Trzebiatowski *et al.*, 1996; Kolman, 2006) or a 5 percent ketamine solution, which is diluted with physiological saline at a ratio of 1:3 before irrigation, as well as intravenous injection of 5 percent ketamine-hydrochloride solution (ketamine –  $C_{13}H_{16}ClNO$ ), 4–10 mg/kg of fish weight. The anaesthetic effect is achieved in 4–5 min and continues for about 10 min. Benzocaine ( $C_9H_{11}NO_2$ ) (0.3 g/liter) in 0.06 g dosage, lidocaine ( $C_{14}H_{22}N_2O$ ) (0.4 g/liter) in 0.08 g dosage, and novocaine ( $C_{13}H_{20}N_2O_2$ ) (0.4 g/liter) in 0.1–0.2 g dosage were also used for irrigation of gills during anaesthesia of Russian sturgeon spawners (Golovanova *et al.*, 2004).

Fish are considered “ready for the procedure” after full immobilization and cessation of gill cover movement

#### **5.1.4 Milt collection and hypothermal preservation**

The collection of milt from large males (above 7 kg) is performed using an urethral catheter and a plastic disposable Janet’s syringe (150 ml) (Parauka, 1993), while in smaller fish milt is collected by flexing males and directing seminal fluid into a dry bowl. In the case of delayed application, the sperm should be stored for a short period at a temperature lower than that at which the males are being held.

The application of Janet’s syringe does not require any transfer of collected milt to a container and thus excludes contamination by water and slime. Additionally, any quantity of milt may be measured out by the syringe’s graduation scale (Figure 66).



**Figure 66:** Janet's syringe and urethral catheter.



The standard set comprises 10 catheters of five different sizes. This allows selection of the catheter that can be firmly inserted into the genital opening without damaging it. The catheter is placed on the Janet's syringe, which should be dry and clean. The male is positioned ventral side to the very edge of the table, compressing the genital opening; the abdominal area is then thoroughly dried with a paper towel to avoid sperm leakage and contamination by water. The loose end of the catheter is inserted 3–5 cm into the genital opening to collect milt (Figure 67). The walls of the spermatic duct should not be sucked into the catheter, as this may lead to contamination of the milt by blood. At sampling, it is necessary to cull ejaculates with evident clots of blood, bile or other contaminants.

**Figure 67:** Milt collection.



In some instances, it is necessary to provide hypothermal storage of the earlier collected (1–2 d and more) sperm. To achieve this, the sperm is collected into dry polyethylene packages or other dry containers filled with a 1:1 mix (oxygen: air) or (somewhat worse) with pure oxygen, where it is stored at a temperature of 0–0.5 °C (not higher than 3 °C) in a thin layer (not more than 0.5 cm thick). The packages may be stored in domestic refrigerators, transport



containers (medical cold bags may be used) or in styrofoam boxes with ice (which cannot provide temperatures lower than 4 °C during transportation); the speed of sperm cooling must not exceed 15 °C/h (10 °C/h is better). Di Lauro *et al.* (1994), changing oxygen every day, managed to preserve the sperm of Atlantic sturgeon (*A. oxyrinchus*) for five days with 80 percent motility and 99 percent survival ability; satisfactory sperm quality was observed in one specimen after 17 d of storage. It should be mentioned that jolts and vibrations should be avoided during transportation, as this will agitate the transported milt.

### **5.1.5 Sperm quality evaluation**

The following three systems for evaluation of sturgeon sperm quality are in use:

#### **5.1.5.1 Spermatozoa motility according to Persov's scale (Persov, 1941)**

- 5 points – rapid forward motion of all spermatozoa observed
- 4 points – rapid forward motion of most spermatozoa observed, but zigzagging and oscillating movement of spermatozoa can be evident in the field of vision
- 3 points – rapid forward motion of some spermatozoa, but zigzagging and oscillating movement prevails, some immobile spermatozoa can be seen
- 2 points – forward movement is almost absent, some oscillating movement is observed, the percent of immobile spermatozoa is high (up to 75 percent)
- 1 point – all the spermatozoa are immobile

In order to study the motility of spermatozoa, samples are diluted by water at a ratio of 1:20 – 1:50, the temperature used corresponding to that of the ejaculate. Samples where activation of spermatozoa is observed without water and ejaculates with clumping of spermatozoa should be culled.

#### **5.1.5.2 Concentration of sperm in the unit of ejaculate**

Concentration of sperm in the unit of ejaculate (assessed visually, billion/ml):

- aqueous, color of milk whey: < 1
- liquid, color of diluted milk: 1–2
- color of full cream milk, sometimes with yellowish tint: > 2

Ejaculates with sperm concentrations of 1 billion per ml are not recommended for insemination or for hyperthermal storage (Table 19). Trials have revealed that 500 000 mobile spermatozoa is the optimal dosage for fertilization of one egg of Russian sturgeon, while 300 000 is optimal for stellate sturgeon (Trusov and Pashkin, 1964).

**Table 19:** Quantity of spermatozoa per cm<sup>3</sup> of ejaculate (data from Ginsburg (1968) except where indicated).

Species	Sperm quantity, billion		
	Minimum	Maximum	Average
<i>H. huso</i>	0.58	6.4	2.51
<i>A. gueldenstaedtii</i>	1.07	3.16	–
<i>A. gueldenstaedtii colchicus</i>	0.14	7.55	2.56
<i>A. gueldenstaedtii persicus</i>	0.6	1.5	–
<i>A. stellatus</i>	0.90 <sup>1</sup>	10.37 <sup>1</sup>	3.19 <sup>1</sup>
	0.12	7.30	2.89
<i>A. ruthenus</i>	0.59	2.41	–

<sup>1</sup> from Persov 1975.

### 5.1.5.3 The norm of spermatozoa activity in water maintenance

The average duration of activity of spermatozoa maintained in water is above three minutes (Table 20). Spermatozoa concentration may be determined more accurately by the use of the common method of haemocytometry.

**Table 20:** Duration of sperm ability to maintain fertilization rate under conditions of hypothermic preservation (d) depending on initial activity and time of motility preservation (Anon., 1986).

Motility, points	Duration of hypothermal preservation, d			
	motility > 5 min	motility 3–5 min	motility 2–3 min	motility < 2 min
4-5	1	2–3	4–5	5
3	0	1	2–3	3–4
2	0	0	0	< 1
1	sperm not subjected to hypothermal preservation			

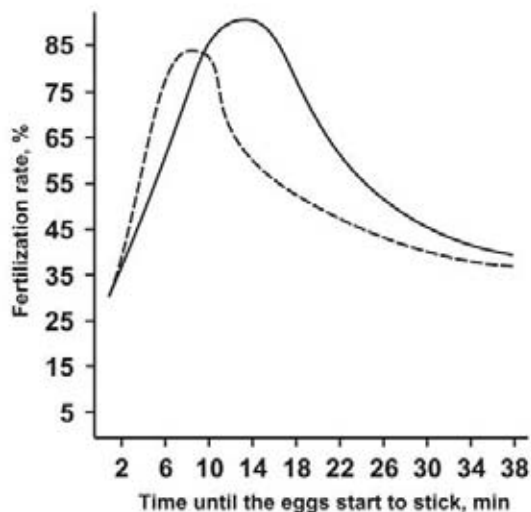
The exact and impartial evaluation of sperm quality calls for the use of the modern methods of flow cytometry, enabling measurement of the speed and mechanical trajectory of male germ cells, the concentration, the quantities of live and dead cells, and other characteristics via the use of computer programs and video monitoring (Billard *et al.*, 1999, Cosson *et al.*, 2000; Pavlov, 2006). Unfortunately, sturgeon farming does not generally employ these methods practically; however, their application is necessary for the conservation of rare and vanishing sturgeon species, the selection of males for broodstock development and in the cryopreservation of sperm. Where sperm from different males are mixed in a single container, their viability exhibits a sharp decrease and can be lost in 20–30 min.

### 5.1.6 Evaluation of egg quality

The quality of the eggs and their fertilization ability should be assessed visually by examining the uniformity of colouration, regularity of shape, absence of resorbed and activated eggs, transparency of the ovarian fluid, etc. The elasticity of the eggs and their ability to become sticky following exposure to water may be also used as maturity assessment criteria. Variation in the degree of adhesiveness of eggs from seven sturgeon species has been revealed by Vorobyeva and Markov (1999). Anadromous sturgeon species tend to have highly adhesive eggs, but it was revealed that green sturgeon (*A. medirostris*) has a low rate of egg stickiness (Deng, Van Eenennaam and Doroshov, 2002).

In the case of ripe Russian sturgeon eggs, the optimal time (i.e. the time required for sticking of 90–95 percent after insemination) ranges from 8–19 min post-insemination, while that for beluga ranges from 4–6 min and for stellate sturgeon, from 5–12 min (Gorbacheva, 1977). The time of stickiness of overripe eggs is 4–6 min for Russian sturgeon and 2–4 min for stellate sturgeon. Low fertilization ability and high mortality rate during embryonic development are typical for such eggs (Figure 68).

**Figure 68:** Relationship between time of stickiness to substrate and ability to fertilize inseminated eggs: solid line – Russian sturgeon; dashed line – stellate sturgeon (Gorbacheva, 1977).



Where perfect quality eggs are unavailable, such (overripe) eggs can be used for reproduction, but their incubation should be performed at a low rate of loading of the incubation system. The resulting larvae should be grown in ponds at lower stocking densities during the first fortnight (Chapter 6). The longer time interval between insemination and adhesion is an indicator of the delay in ovulation, while a shorter interval shows the over-maturation of females. Hence, this express

technique provides not only the timing of egg insemination on the basis of the time of stickiness to substrate (rate of onset of egg membrane stickiness), but also allows the selection of eggs of perfect quality for further incubation.

### 5.1.7 Artificial insemination of eggs

#### 5.1.7.1 Insemination procedure

Note that (as is traditional practice) in most hatcheries insemination of all eggs from one female by a mixture of sperm from numerous males does not ensure an appropriate level of genetic heterogeneity of the progeny, which is most important under the conditions of a limited number of broodstock and low effective size of artificially built populations. This is due to the heterogeneity of sperm obtained from multiple donors.

Sperm from different males exhibit diverse motility and concentration, depending mainly on the physiological status of the males, as well as on prior conditions during holding and the schedule and timing of ejaculate collection. Where insemination of eggs from one female occurs by mixed sperm of different quality, the probability of one male being more successful in producing the resulting progeny is high, which is unacceptable when building heterogeneous stocks or populations. In order to get genetically heterogeneous progeny, it is reasonable to divide the eggs obtained from one female into three to five batches (Figure 69), inseminating each batch with the sperm from a single male. The fertilized eggs may then be mixed, de-adhesed and incubated. Where there is a sharp decline in the number of wild females used by hatcheries, an increase in the number of males destined for mating allows the effective size of artificial populations to be increased (Chebanov, Galich and Chmyr, 2004).

**Figure 69:** Dividing eggs into portions intended for insemination.



Insemination of eggs is performed using the semidry “Russian” method. This technique allows prevention of polyspermy. Polyspermy is associated

with the occurrence of a large number of micropyles in sturgeon eggs (average values: Russian sturgeon – 9.7; beluga – 6.6; stellate sturgeon – 4.8; Aral ship – 7.2; South Caspian ship – 4.2; sterlet – 6.7) (Ginsburg, 1968; Vorobyeva and Podushka, 1999; Podushka, 1999, 2008a; Debus, Winkler and Billard, 2002).

It should be noted that a few hours after ovulation a partial layer of follicular cells can be evident on the surface of ovulated oocytes. Sometimes the layer covers the micropyle field and impedes fertilization. Due to this reason, Billiard (2000) recommended to conduct insemination one hour after egg extraction.

For short-term egg preservation (e.g. in the case of mass female maturation and lack of males), they should be kept under the layer of ovarian fluid (Gisbert and Williot, 2002a). Before sperm is added to the eggs, excess coelomic fluid should be gently and quickly poured out of the container, since it affects egg fertilization. Sturgeon eggs rapidly lose their fertilizability if they come in contact with air or are exposed to direct sun light or high temperature (above spawning temperature range). For this reason, the eggs should be preserved before insemination and insemination performed in the shade (Dettlaff, Ginsburg and Schmalhausen, 1993).

Eggs and sperm are collected into dry containers. To provide the highest probability of monospermic insemination, sperm should be added to water by making a 1:200 dilution (10 ml or a bit more at low sperm quality per 2 liters of water). This ratio may be changed a bit depending on the quantity of the ovarian fluid in the eggs. The excessive use of fertilizing solution when applying the semidry technique does not lead to negative consequences; hence, it is necessary to have a proper concentration (eggs to solution) that ensures the contact of all eggs with fertilizing solution and easy mixing. As the fertilizing solution is added, the eggs are immediately thoroughly mixed for two minutes (Figure 70). In the past, a “two cycle” insemination approach was used that involved pouring all the fertilizing solution from the container 50–60 s after insemination and then adding a fresh solution with sperm to complete insemination.

**Figure 70:** Eggs insemination.



In the research work of Billard *et al.* (1999), a two-fold dilution of milt was applied to provide the synchronous activation of all spermatozooids. At first the milt was diluted at a ratio of 1:20 using a dilutant with an osmotic concentration close to that of seminal fluid, causing no activation of the male germ cells, and then a further dilution at a ratio of 1:30 was made using activating solution. In this case, with its ultimate dilution of milt at a ratio of 1:600, the best activation of the sperm of Siberian sturgeon was achieved.

#### **5.1.7.2 Duration of insemination**

The duration of exposure of eggs to the sperm solution is determined in accordance with such recommended standard parameters as:

- sperm viability;
- duration of the ability of the eggs to be fertilized; and
- time before the eggs start to become sticky.

Previously, recommendations (Anon., 1986) established the duration of insemination for different sturgeon species as 3 to 5 min, thus assuring the maximum potential performance of sperm for fertilization. At the same time, almost all eggs capable of insemination are fertilized during the first 30–60 s. The eggs of some species (especially sterlet) become highly adhesive before the completion of fertilization, thus complicating the operation. Actually, within 30 s post-activation, the progressive motion of the male germ cells slows significantly, and two minutes later the number of active male germ cells falls below 10 percent (Billard, 2000). It should be noted that Mohler (2003) recommends mixing the eggs manually with fertilizing solution for only one minute, and then no motions are made for one to two minutes.

#### **5.1.8 De-adhesion of eggs**

Although mineral silt or talcum can be used as de-adhesive substances, each has its shortcoming, “Blue clay” or fuller’s earth is a much more effective substance (Podushka, 1999).

Tannin is also an effective substance, but its application requires accurate measurement of both the dosage and time for treatment (Table 21); exceeding either of these parameters can cause eggs mortality (Chebanov, Galich and Chmyr, 2004). Rottmann, Shireman and Chapman (1991) described a different technique of more prolonged (10 min) tannin application at a concentration of 0.15 g/liter, but this method has not been widely used.

Eggs are subjected to de-adhesion in special systems or manually (Figures 71, 72). Recommendations on the application of different substances for egg de-adhesion are presented in Table 21.

**Figure 71:** System for egg de-adhesion.



**Figure 72:** Manual egg de-adhesion.





**Table 21:** Summary of recommendations on sturgeon egg de-adhesion..

De-adhesion substance	Preparation	Concentration per kg of eggs	Duration of treatment	De-adhesion technique
Mineral silt	Prepared in autumn, purified, heat disinfected, stored as a creamy suspension	1 liter of suspension per 5 liters of water	35–45 min	In an anti-adhesive treatment unit or by hand in an enamel-coated, aluminum or plastic container
Talcum	Diluted in water immediately prior to de-adhesion	100 g per 5 liters of water	45–60 min	–
“Blue clay” (Russian State Standard 5142-00146893474-97) (Podushka, 1999)	Stored in dry state, diluted with boiling water 1 d prior to application as a creamy liquid	300 g of dry clay per 5 liters of water	35–45 min	–
Tannin	Diluted in water immediately prior to application	2.5 g per 5 liters of water	40 s	By hand (only)

At de-adhesion, the silt suspension is poured into the container, then the mixture is placed into the de-adhesion system or gently mixed by hand. To ensure sufficient saturation of the suspension by oxygen, freshly aerated water (20–25 percent of the total volume) is added 15–20 min after adding the silt. The duration of de-adhesion depends on the sturgeon species (i.e. egg stickiness).

After de-adhesion, the eggs are rinsed with water until the de-adhesion substance is completely removed. Sterilized water should be used for egg insemination and de-adhesion. This water should possess some standard hydrochemical characteristics (e.g. low oxygen level) and be at spawning temperature.

## 5.2 EGG INCUBATION

### 5.2.1 Incubation systems

Special systems are used to provide continuous rinsing of the eggs by water and their lifting in the water column. The de-adhesed eggs should be placed into an egg incubation system, ensuring their even covering with water and their lifting into the water column.

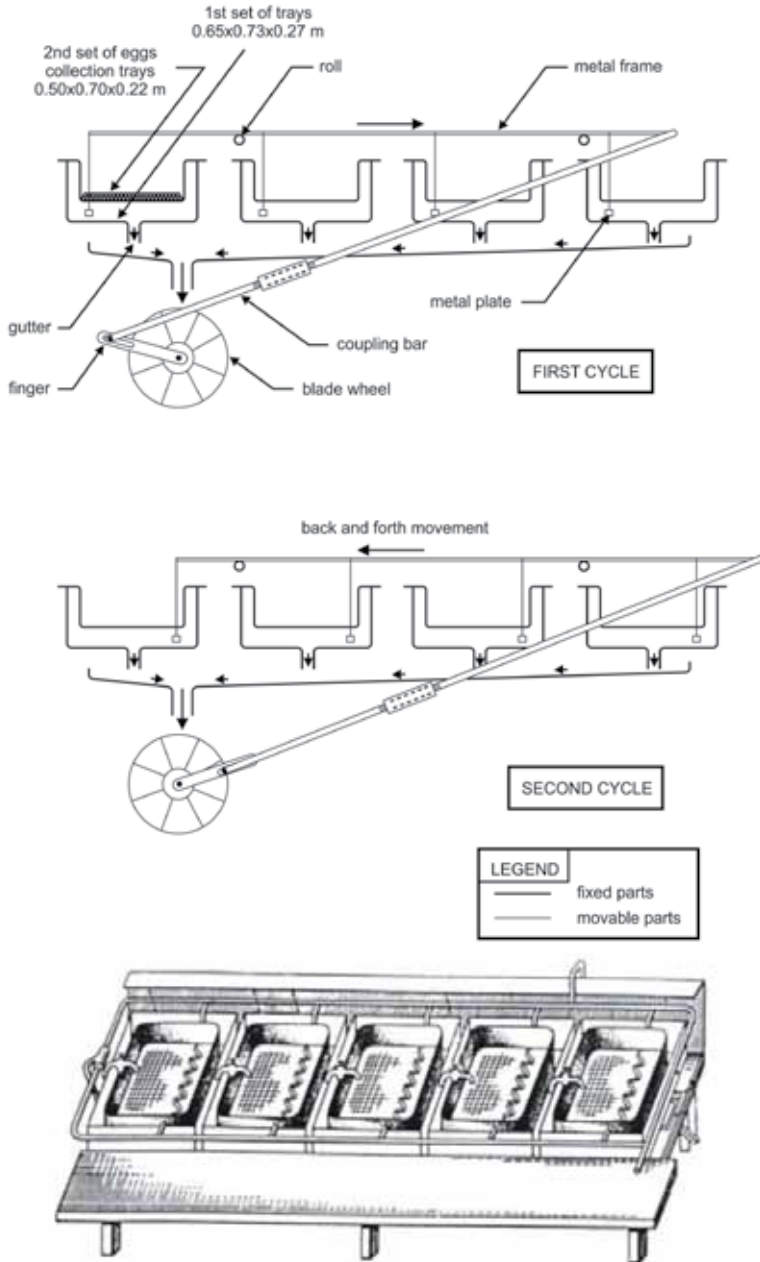
#### 5.2.1.1 Yuschenko system

The Yuschenko system (Figure 73) consists of outer and inner (with a brass sieve of mesh size 0.8 mm) boxes. Below the sieves are a few special frames (equipped with a swivel-driven device without an electric motor) that create vortex water



flows that mix the eggs. The time interval between two successive movements of the blade depends on the rate of the ladle filling with water. In turn, the duration that the eggs remain suspended depends on the blade movement interval.

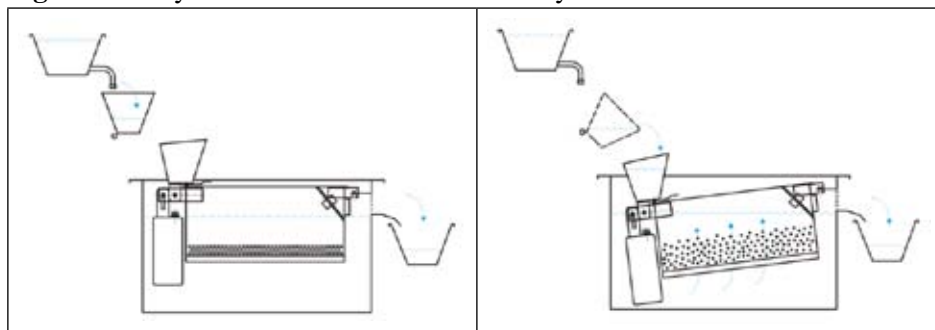
**Figure 73:** Layout of one incubation box with eggs (Yuschenko system).



### 5.2.1.2 “Osetr” incubation system

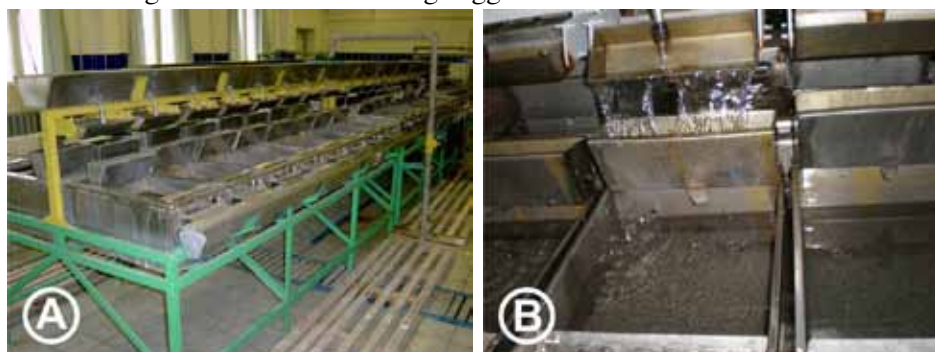
The “Osetr” incubation system consists of a support construction, two containers with eight incubation boxes (trays) each, inlet and outlet channels and a larval collecting tank (Figures 74, 75).

**Figure 74:** Layout of the “Osetr” incubation system.



Egg incubation is performed in a suspended state that is ensured by periodic movement of trays and by periodic delivery of water from the tipping bucket. After hatching, the larvae are transported to the collecting tank. The incubation of eggs in modified noiseless “Osetr” systems enables higher hatching and survival rates (Tikhomirov and Nikonorov, 2000).

**Figure 75:** “Osetr” incubation system: **A** – side view of the system; **B** – incubation boxes during the incubation of beluga eggs.



Note that a fully loaded “Osetr” system holds about two million fertilized eggs. In recent years, modified two to four box “Osetr” systems have been routinely used, especially at small sturgeon hatcheries. Moreover, in some cases, it is effective to install incubation boxes directly in the tanks or troughs, such that the newly hatched prelarvae run off along with the water flowing from the boxes (Figure 76). Similar constructions were used at Krasnodar sturgeon hatcheries 30 years ago (Orlov and Garanov, 1977).

**Figure 76:** Modified “Osetr” incubation system.



### 5.2.1.3 MacDonal and Weiss incubation systems

In cases where there are a rather small amount of eggs, it is wise to use conventional Weiss or MacDonal jars (these are widely applied in aquaculture), either as a system of multiple (9–10) jars (Conte *et al.*, 1988) or separately, ensuring hatching of prelarvae directly into the rearing tank (Figures 77, 78, 79).

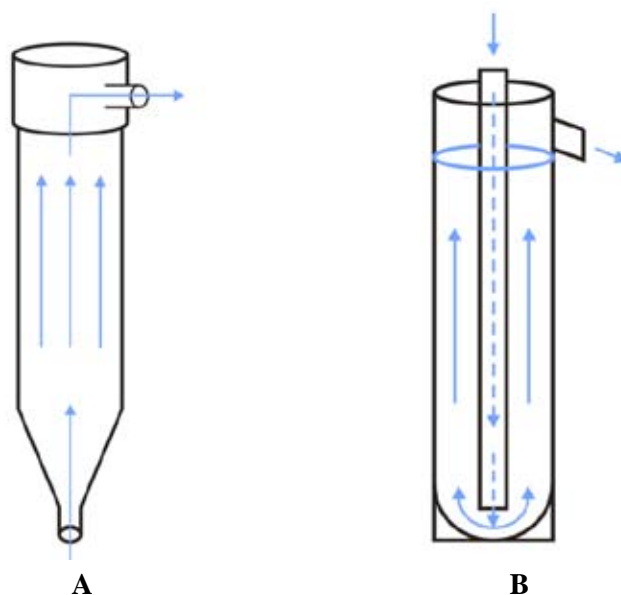
**Figure 77:** Weiss incubation jars.



**Figure 78:** MacDonald jar system: **A** – incubation jar line; **B** – separate jars installed in the rearing tanks for prelarval hatching.



**Figure 79:** Layout of incubation jar systems: **A** – Weiss; **B** – MacDonald. Arrows show the flow direction within the systems.



#### 5.2.1.4 Preparation of incubation systems

Before loading eggs, it is recommended to check the system's water inlet and outlet, their completeness and the state of the incubation sections (boxes). The water supply system should be rinsed with freshwater, disinfected and rinsed again. The water demand is adjusted depending on the system type.

### 5.2.2 Norms for egg loading into incubation

When loading into incubation cells, the quantity of incubated eggs is determined by volumetric or weight methods. The norms for egg loading into incubation cells are given in Table 22.

**Table 22:** Norms for egg loading into the incubation system.

Species	Norm of loading, thousand eggs					Weiss (8 liters)
	Yushchenko (YU-II) (per 1 section)	“Osetr” (per 1 incubation box)	MacDonald			
			5 liters	6.5 liters	13 liters	
Russian sturgeon	220–250	130–150	15	20	40	25
Stellate sturgeon	240–260	200–220	20	25	50	30
Beluga sturgeon	150–165	100–110	13	17	35	20
Ship sturgeon	220–250	130–150	15	20	40	25
Sterlet	200–250	200–250	23	30	60	35

Note that loading norms for “Osetr” incubation systems have been elaborated and used at hatcheries of the Azov and Caspian basins (Anon., 1986) during years of large scale wild breeder collection and the need for the one-time incubation of millions of eggs. Under present conditions where there is a lack of breeders, it is essential to use loading norms for the “Osetr” system that are decreased by 20–30 percent.

### 5.2.3 Water demand for the incubation system

The water demand for the incubation system depends on its type. During the process of embryogenesis, the oxygen demand (per 1 g of live weight and one egg) increases considerably: 20–25 times in the case of Russian sturgeon, 15–17 times for stellate sturgeon and 39–50 times for ship sturgeon (Korzhev, Nikolskaya and Rodzieskaya, 1960). The dissolved oxygen level should be maintained in excess of 7.5 mg/liter. An oxygen concentration lower than 6.0 mg/liter (80 percent saturation) may cause malformations in development (cardial hypertrophy, pericardial oedema, etc.), while 3–3.5 mg/liter can lead to total embryo mortality. In order to create a favourable oxygen regime (6.6–9.0 mg/liter) in the systems, it is necessary to provide a water demand for the MacDonald jar (13 liter) ranging from 4–5 liter/min (30–40 percent of the volume per minute) to 10 liter/min at the final stages (Conte et al., 1988) and within the range of 1–8 liter/min for the Weiss jar.

Water demand standards for embryonic development are stage dependent and are given in Tables 23 and 24 for the Yushchenko and “Osetr” systems, respectively.

**Table 23:** Specific water inflow rates for the Yushchenko system (Milshtein, 1982).

Developmental stage	Period of frame movement, s	Specific water rate, liter/min/100 000 eggs	
		Beluga and Russian sturgeons	Stellate sturgeon
From morula to the end of gastrulation	40–45	2.4	1.2
From the end of gastrulation to slow movement stage of embryo	30–35	3.4	1.7
From embryo being able move to forward quickly to onset of larval hatch	20–25	5.5	3.3

**Table 24:** Specific water inflow rates for the “Osetr” system (Anon., 1986).

Stage of development	Specific water rate liter/min/100 000 eggs
Cleavage division	2.0–2.3
Gastrulation	2.3–3.0
Onset of heartbeat	3.0–4.5
Embryo capable of movement	4.5 5.0
Onset of hatching	5.8–6.2

### 5.2.4 Illumination

The level of illumination for the incubation system should be adjusted in accordance with species-specific requirements (i.e. beluga sturgeon, less than 100 lux; stellate sturgeon, 20–100 lux; Russian and ship sturgeons: 10–20 lux) (Kasimov, 1987). At higher illumination, the number of developmental abnormalities tends to increase, while viability of embryos decreases.

### 5.2.5 Control of sturgeon egg incubation

The persistent monitoring of constant water supply, gas, and hydrochemical and temperature regimes (diurnal variation should be not higher than 2 °C) should be performed, along with the timely removal of undeveloping eggs.

Ultraviolet (UV) light sterilization, thermoregulation and sanitary operations (Chapter 12) may be applied in order to prevent saprolegniosis. The application of Violet “K” ( $C_{24}H_{28}N_3Cl$ ) has proven to be most efficient (Mamedov, 2000).

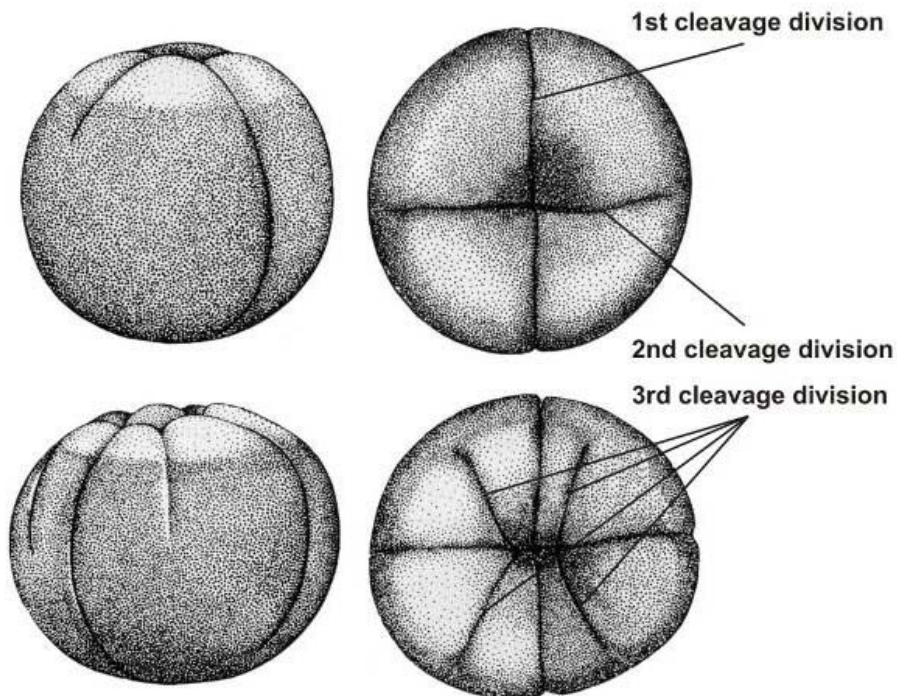


### 5.2.5.1 Determination of egg fertilization rate

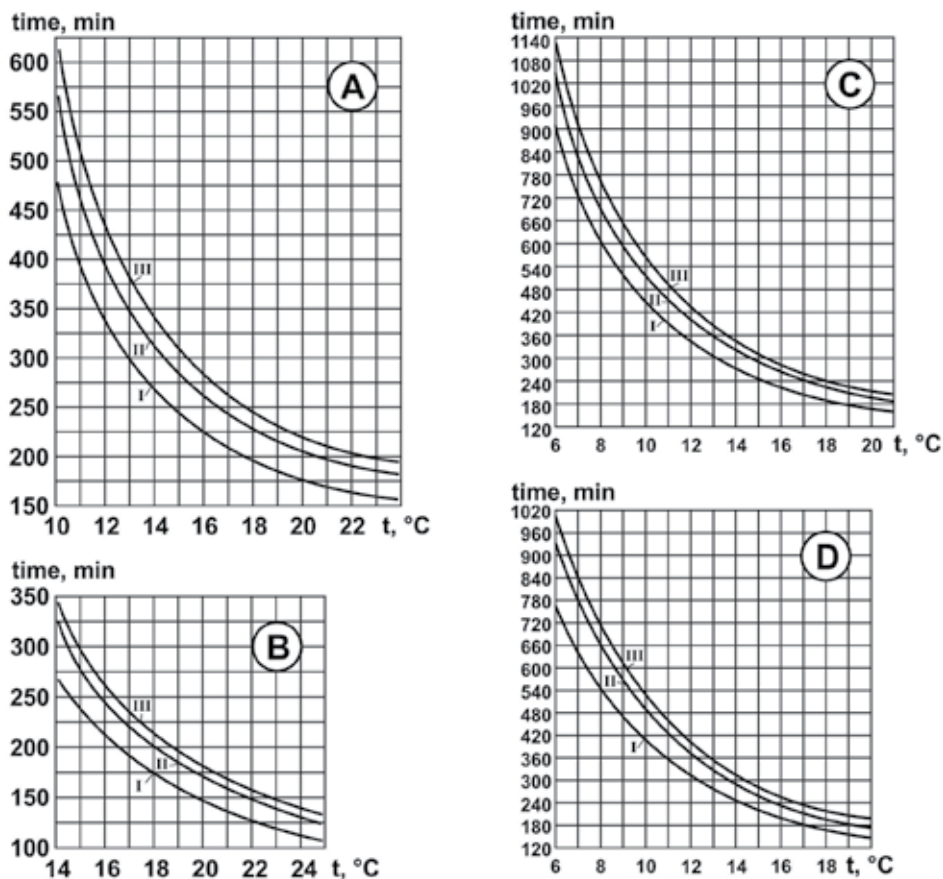
The percent (ratio) of normally fertilized embryos to dead ones is determined to assess the hatchery quality of the incubated eggs. Eggs of perfect quality possess clear (transparent) membranes (envelopes) that allow the course of embryogenesis to be observed, while dead eggs have considerably larger size as compared to normally developing embryos and a specific “marble” or dull white colouration.

The initial fertilization percent is calculated at the 2<sup>nd</sup> or 3<sup>rd</sup> cleavage division (4 or 8 blastomere stage) (Figure 80). The time for sampling depends on the water temperature and is presented in Figure 81.

**Figure 80:** Embryo at 2<sup>nd</sup>–3<sup>rd</sup> cleavage division (Dettlaff, Ginsburg and Schmalhausen, 1993).



**Figure 81:** Timing of sampling for fertilization rate determination for eggs in relation to incubation temperature: **A** – Russian sturgeon; **B** – stellate sturgeon; **C** – giant sturgeon; **D** – sterlet (Dettlaff, Ginsburg and Schmalhausen, 1993). The curves show time between insemination and appearance of fissures at second (I) and third (III) cleavage division; (II) – the best time for sampling.



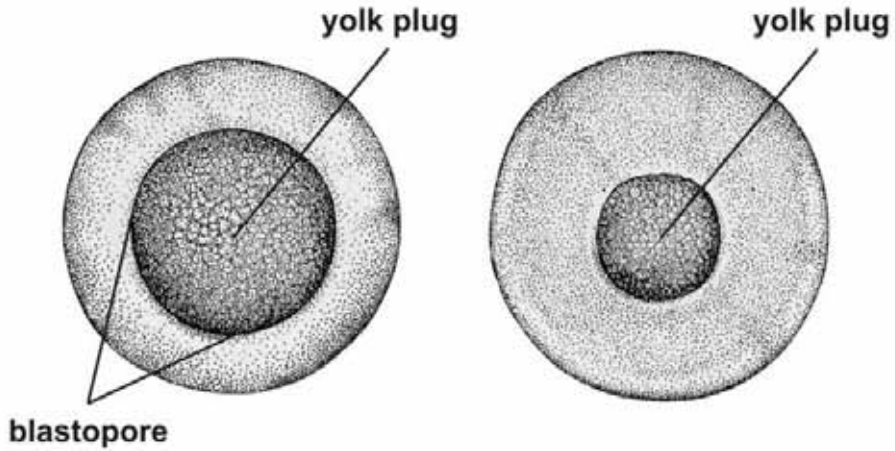
For determining the fertilization rate, a random sample of 100–200 fertilized eggs should be taken from a well-mixed incubator and examined visually or using a binocular microscope; dead, unfertilized, activated and polyspermic eggs are removed and then the number of normally fertilized embryos in the total amount of eggs in the sample counted to give the percentage.

### 5.2.5.2 Further observations on egg development

The synchronicity and adequacy of embryonic development of sturgeon eggs should be monitored in the course of incubation. It is more convenient to perform the control at the “large and small yolk plug” stages (stages 16–17) (Figure 82).



**Figure 82:** Normal development of embryo at stages 16–17 (Dettlaff, Ginsburg and Schmalhausen, 1993).



It should be noted that the final decision about the possible transportation of the egg lot (batch) is routinely made only after completion of this stage. At this time (31.4 h after insemination at 18 °C for Russian sturgeon) (Table 25), all the unfertilized eggs are dead and the normally developing embryos either do not have a yolk sac or have a very small one.

**Table 25:** Chronology of embryonic development in *A. gueldenstaedtii* colchicus (Dettlaff, Ginsburg and Schmalhausen, 1993).

Stage	Time after insemination		Specific features of stage
	h and min at 18 °C	Number of $\tau_0^1$	
1	0	0	Egg at the moment of fertilization
2	~ 0.50	~ 1	Light polar spot disappeared; perivitelline space formed
3	~ 1.40	~ 2	Pigment accumulation in animal region eccentric; light crescent formed
4	2.55	3.5	Animal region divided by the 1 <sup>st</sup> cleavage furrow
5	3.45	4.5	Animal region divided into 4 blastomeres
6	4.35	5.5	Animal region divided into 8 blastomeres
7	5.25	6.5	Furrows of 4 <sup>th</sup> cleavage division appeared on the surface of animal blastomeres
8	6.15	7.5	Furrows of 5 <sup>th</sup> cleavage division appeared on the surface of animal blastomeres
9	7.3	9	7 <sup>th</sup> cleavage division; furrows divide vegetal area completely
10	8.2	10	Blastocoel begins to form; nuclear divisions in animal region are still synchronous
11	10	12	Late blastula; individual cells in animal region are indiscernible at low magnification
12	12.3	15	Geç blastula; hayvansal bölgedeki hücreler düşük büyütmede açıkça seçilememektedir.
12+	14.1	17	Rearrangement of cell cycle in blastomeres of animal region; drop in mitotic index
13	16.5	19.5	Beginning of gastrulation; highly pigmented band formed at equator level in region of future dorsal lip of blastopore
14	17.05	20.5	Early gastrula; invagination of material through dorsal lip of blastopore over a small area
15	22.55	27.5	Middle gastrula; animal material covers 2/3 of surface of embryo; blastopore closed in rings
16	25.00	30.0	Yolk plug of considerable size
17	27.50	32.5	Small yolk plug
18	31.40	38.0	Gastrulation completed, blastopore slit-like
19	32.30	39.0	Early neurula; neural folds around head region begin to show
20	33.45	40.5	Wide neural plate; neural folds around head region of neural plate clearly defined
21	34.45	41.7	Neural folds begin to draw together; rudiments of excretory system begin to show for the first time
22	36.4	44	Late neurula; neural folds in trunk region draw together, rudiments of excretory system longer
23	37.30	45	Neural tube closed; suture along the line of neural folds fusion clearly discernible
24	–	–	Eye processes formed; thickening appears in anterior parts of rudiments of excretory system

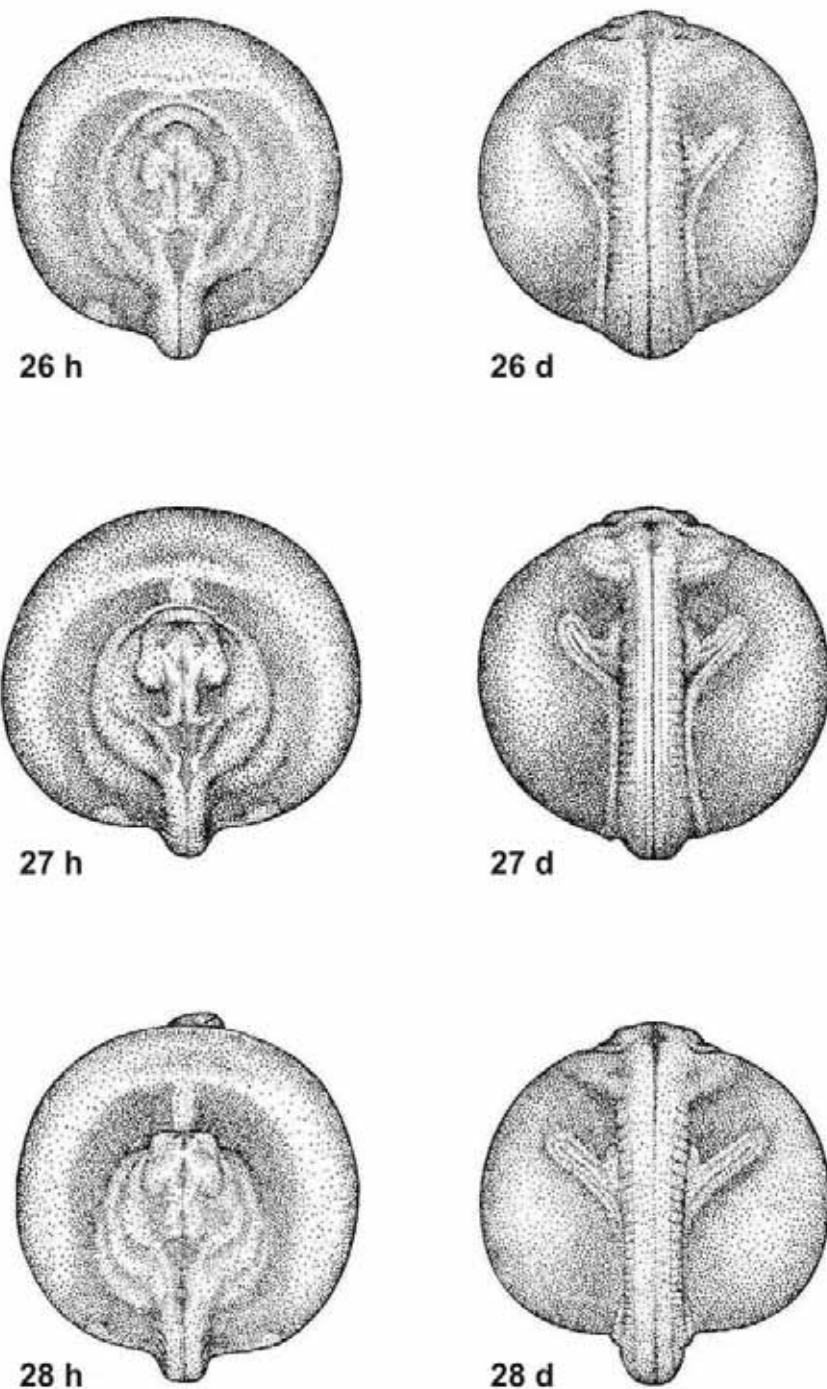
25	–	–	Lateral plates reach anterior end of head, their tapering ends come together in front of hatching gland rudiment; common rudiment of posterior trunk and tail regions appears as a thickening at the posterior end of the body
26	50.00	60.0	Lateral plates fuse and rudiment of heart forms at the site of their fusion, body fold undercuts rudiment of posterior trunk and tail, making it project freely over the yolk sac surface
27	53.20	64.0	Short, tube-like heart rudiment formed
28	57.30	69.0	Heart rudiment as straight elongated tube; trunk muscles do not yet contract in response to stimulation
29	60.00	72.0	Heart tube assumed S-shaped flexure, begins to beat; trunk muscles twitch in response to pricking
30	62.05	74.5	Tip of tail of embryo in membranes approaches heart; posterior trunk region and tail begin to straighten out
31	–	–	Tip of tail of embryo in membranes reaches heart; embryo can move head and tail
32	78.00	93.5	Tip of tail of embryo in membranes touches head
33	–	–	Posterior trunk region and tail straighten out completely after removal of membranes
34	–	–	Embryo removed from membranes can move forward slowly
35	104–106.40	125–128	Hatching of individual prelarvae; embryo can move forward quickly after removal of membranes
36	–	–	Mass hatching

<sup>1</sup>  $\tau_0$  – duration of one mitotic cycle during synchronous cleavage divisions.

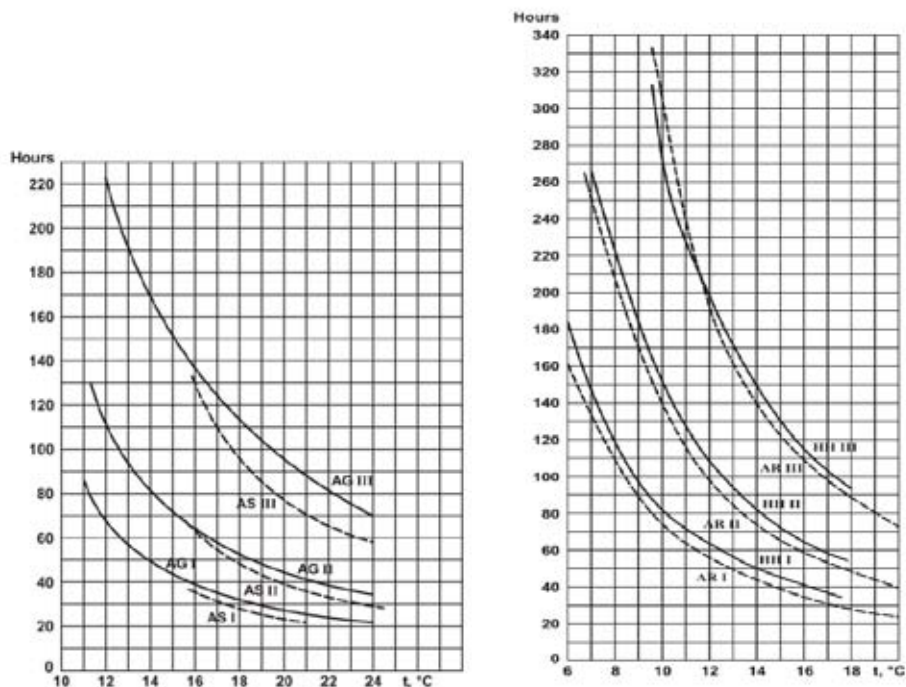
Further control is carried out at the stages of heart rudiment formation (stages 26–28), when the expected yield of prelarvae is clearly associated with the number of normally developing embryos (Figure 83).

Optimal time of sampling intended for controlling embryogenesis depends on the thermal regime used for egg incubation (Figure 84).

**Figure 83:** Normally developed embryos at stages 26–28 (Dettlaff, Ginsburg and Schmalhausen, 1993): **h** – view from the heart segment; **d** – view from the spinal part.



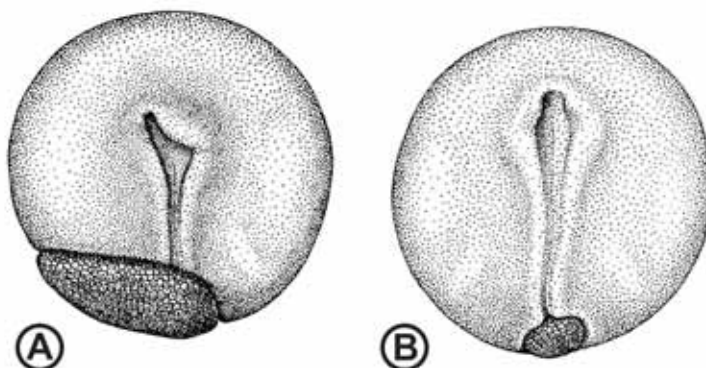
**Figure 84:** Duration of development of the embryos of *A. gueldenstaedtii* (AG), *A. stellatus* (AS), *H. huso* (HH), *A. ruthenus* (AR), and the time of collecting samples for estimation of the normality of development as a function of temperature (Dettlaff, Ginsburg and Schmalhausen, 1993). **I** – time from insemination to the end of gastrulation (stage 18); **II** – stage of fusion of lateral plates before the formation of heart rudiments (stage 26); **III** – stage of hatching of individual prelarvae (stage 35). Ordinate – time after insemination, h; abscissa – temperature, °C.



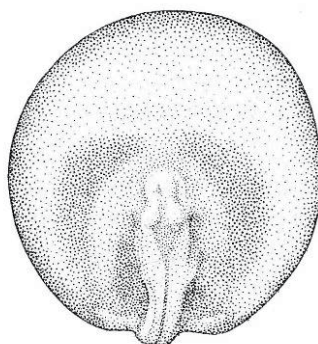
### 5.2.5.3 Abnormalities in normal development of embryos

Typical abnormalities in the normal development of embryos associated with various stages were described in detail in Dettlaff, Ginsburg and Schmalhausen, (1993). The more frequently encountered are presented in Figures 85, 86 and 87.

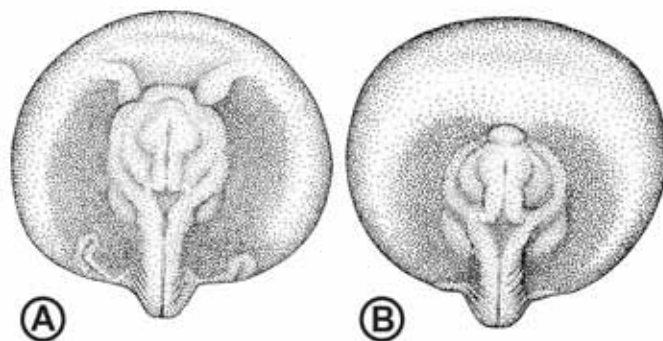
**Figure 85:** Formation of the neural plate in the presence of a plug of anomalous size (Dettlaff, Ginsburg and Schmalhausen, 1993). **A** – a large yolk plug, the neural plate is shortened and curved; **B** – a smaller yolk plug.



**Figure 86:** Undevelopment of front body parts (absence of the prosencephalon) at stage 26 (Dettlaff, Ginsburg and Schmalhausen, 1993).



**Figure 87:** Abnormalities of heart rudiment formation – appearance of embryos with two heart rudiments (**A**) or its lack (**B**) (stages 27–28) (Dettlaff, Ginsburg and Schmalhausen, 1993).





The majority of malformations observed in sturgeon embryos occur during the process of gastrulation. Disturbances in gastrulation appear in response to an irregular holding regime of brood fish under unfavourable conditions of incubation. If crumpling of eggs is observed in the incubation boxes due to poor de-adhesion, embryos located in the center of the crumple exhibit slower development and enlarged yolk plugs. A similar phenomenon is also observed at overloading of the incubators, due to insufficient water exchange and gas regime disturbances. Eggs of perfect hatchery quality exhibit synchronous gastrulation (differences in developmental stages of eggs should not be greater than 2 stages in a sample). Only a few embryos with a large yolk plug of irregular shape can be encountered at the end of this stage. Wide variation in the size of the yolk plug in eggs of good quality indicates unfavourable incubation conditions and should attract the fishbreeder's attention (Dettlaff, Ginsburg and Schmalhausen, 1993). Changes in rates and desynchronization in embryonic development can be caused by such abiotic factors as mechanical stressors (e.g. transportation-associated vibration) and disturbances in thermal, gas and hydrochemical regimes.

### **5.2.6 Duration of embryogenesis**

The duration of incubation for different sturgeons is water-temperature dependent. The temperature should be maintained within the optimal species-specific range, close to the average value. The optimal temperature range for Russian sturgeon is 16–20 °C, while those for beluga, stellate, sterlet and ship sturgeons are 9–14 °C, 17–24 °C, 13–16 °C, and 14–18 °C, respectively. The overall duration of egg incubation for different species (prior to mass hatching) is shown in Table 26.

Egg incubation at temperature close to the upper limit of the optimal range may negatively affect embryonic development, leading to increased instances of abnormality and yield prelarvae with low levels of yolk reserve. Incubation at the lower end of the range increases the period of incubation and requires much more preventive operations, but hatching prelarvae have larger weight, length and volume of the yolk sac (Kuftina, Zaitseva and Novikov, 1984) and are characterized by further higher growth rate in the course of endogenous feeding (Ruban, 2005).

**Table 26:** Duration of sturgeon egg incubation (modified from Anon., 1986).

Temperature, °C	Duration of egg incubation, h			
	Beluga sturgeon	Ship sturgeon	Russian sturgeon	Stellate sturgeon
10–11	240–235	–	–	–
11–12	230–220	190–180	–	–
12–13	210–200	170–168	–	–
13–14	190–180	155–145	–	–
14–15	170–160	135–125	–	–
15–16	–	115–105	–	–
16–17	–	105–100	–	–
17–18	–	95–90	150–145	–
18–19	–	–	140–130	–
19–20	–	–	120–115	–
20–21	–	–	110–95	100–90
21–22	–	–	90–85	80–70
22–23	–	–	80–75	70–60
23–24	–	–	–	60–50

Once the temperature during embryogenesis is significantly elevated, desynchronization in development can be observed, which is characterized by wide-stage variations resulting in different malformations and prolonged hatching that passes without an evident peak (Dettlaff, Ginsburg and Schmalhausen, 1993). Similar phenomena are frequently observed during egg incubation in hatcheries where the establishment of proper conditions is associated with some technological problems. The monitoring of the thermal regime during incubation avoids the negative consequences of temperature variations beyond the optimal range to be avoided and creates the most favourable conditions for embryonic development, thus preventing development of *Saprolegnia* sp. Thermal regime control should be performed once every 2 h; the daily variation in water temperature should not be higher than 2 °C.





## Chapter 6

### Rearing of larvae, fry and fingerlings

#### 6.1 HATCHING AND HOLDING OF PRELARVAE

##### 6.1.1 Hatching of prelarvae

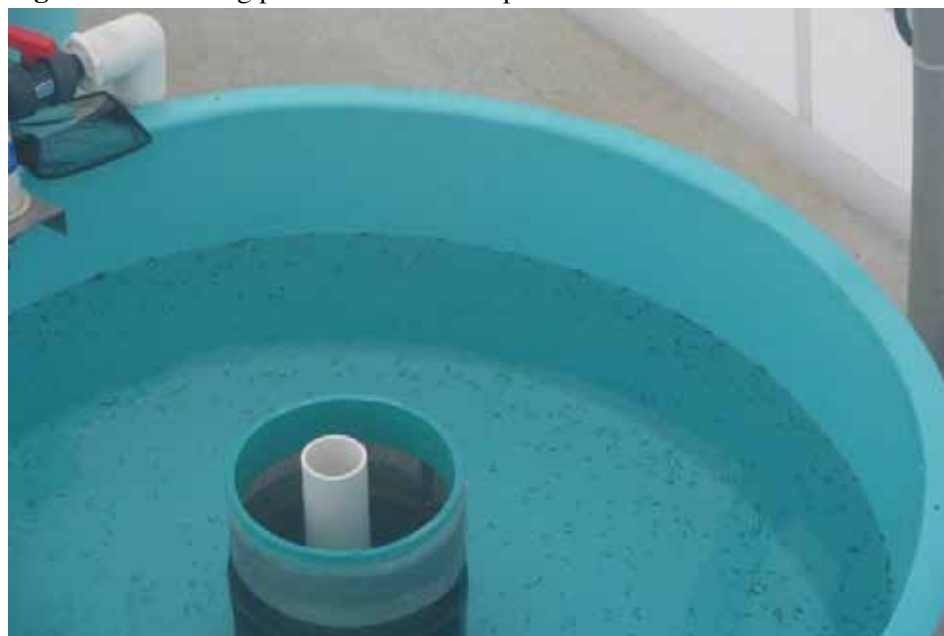
The onset of hatching is characterized by the occurrence of single floating prelarvae in the incubation system. The length and weight of prelarvae of different sturgeon species at hatch are shown in Table 27.

**Table 27:** Prelarval length and weight at hatch for different sturgeon species.

Species	Weight, mg	Length, mm
Russian sturgeon	16–21	10–12
Stellate sturgeon	11–14	8–10
Beluga sturgeon	22–32	13–16
Ship sturgeon	10–14	9–10
Sterlet	8–11	8–9

The hatching prelarvae are transported to circular concrete or plastic tanks (Figure 88) with 2–4 m<sup>2</sup> surface area.

**Figure 88:** Hatching prelarvae in circular plastic tanks.



### 6.1.2 Conditions of prelarval holding

At large number of collected prelarvae (above 0.5 mln) their enumeration can hardly be performed individually and therefore the count is routinely determined by rough estimation. Commonly the numbers are estimated by comparison with a container holding 500 individuals) or by weighing (Figure 89). A few norms related to density of prelarvae, water level and water quality in tanks or trays are presented in Table 28.

**Table 28:** Norms for prelarval stocking density in tanks and trays.

Parameter	Norm
Area of rearing tanks or trays, m <sup>2</sup>	2–4
Stocking density, individuals/m <sup>2</sup>	
Russian sturgeon	5 000
Stellate sturgeon	6 000
Beluga sturgeon	4 000
Ship sturgeon	6 000
Sterlet	7 000
Water level in a tank, cm	20
Oxygen concentration, mg/liter	7–9
Water demand, liter/min	8–9

**Figure 89:** Circular concrete tanks for prelarval holding (A) and plastic trays for larval grow out (B).



On the day after the stocking of prelarvae, the membranes, dead eggs and individuals with anomalies should be removed. The collection of dead eggs and membranes should be performed using a rubber siphon.

### 6.1.3 Patterns of morphogenesis of the prelarval yolk sac

The growth of prelarvae prior to the onset of exogenous feeding (stages 35–42) is provided by the yolk sac supply, which is related to the length of the free embryo. During these stages, differentiation of the main organs (including sections of the digestive system) occurs, and a unified morpho-physiological system is formed

that is capable of sustaining life, typical for different stages of ontogenesis. A higher rate of sturgeon prelarval development is observed at optimization of the thermal regime during embryogenesis. This increase is associated with the temperature during the period of egg incubation and hatching via effects on yolk sac resorption rate, growth and development of the prelarvae.

The initial formation of the yolk sac, a temporary organ, is associated with olfactory function and nutrient provision. During and after the embryonic phase, in the course of sturgeon prelarval development, the shape of the yolk sac changes from round to oval, and then to oval or pear-like. Normal yolk sac height-length ratio ranges from 0.55 to 0.69. For deformed (pear-like or prolonged oval) yolk sacs, this ratio tends to be as low as 0.29–0.44 (Belyaeva, 1983). During the period of holding, before the transition to exogenous feeding, individual variability of prelarval size-weight characteristics tends to decrease, associated with the elimination of nonviable specimens and increase in average length and body weight of prelarvae. This proves the common idea that the fluctuations in weight and length do not exceed 15 percent (Dettlaff, Ginsburg and Schmalhausen, 1993). The high rate of yolk conversion into prelarval biomass (about 2) is typical for the phase of intensive morphological development.

The rate of yolk utilization increases during the process of prelarval development. The acceleration of yolk sac absorption (as compared with the prior passive, laying at the tank bottom period) is a result of the swimming of prelarvae and the activation of morphogenic processes.

#### **6.1.4 Specific peculiarities of phototaxis in sturgeon prelarvae**

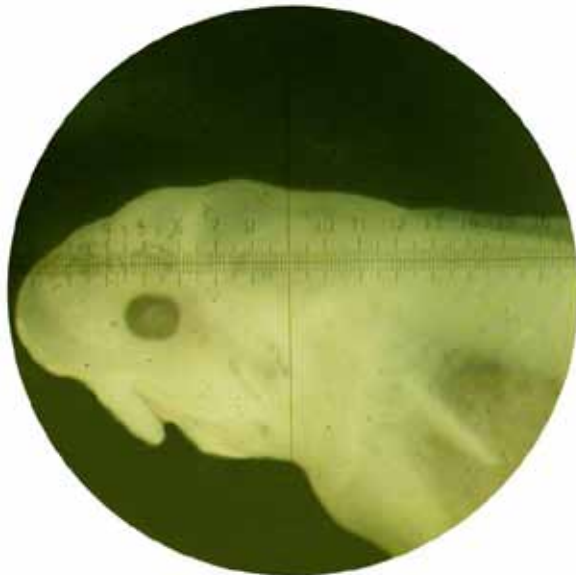
Prelarval response to light is an important diagnostic trait, enabling, in particular, detection of differences between Azov (photophobic) and Volga (photopositive) populations of Russian sturgeon (Podushka, 2003). Positive phototaxis in prelarvae of beluga, stellate, sterlet, Siberian and Russian (Volga population) sturgeons has been revealed, while in ship, Atlantic, Persian and Russian (Azov population) sturgeons, negative phototaxis has been noted. These peculiarities are of practical value, as they necessitate special illumination of the incubation system during the hatching of different sturgeon prelarvae. This is especially important in the case of vertically designed devices with transparent walls (i.e. Weiss and MacDonald systems) during the hatching period of photophobic species and even in the case of facilities with low illumination that requires shading out. Prelarval phototaxis undergoes changes between the onset of hatching and the transition to exogenous feeding. In the case of Russian and ship sturgeons, illumination has to be raised from 2–10 to 80–100 lux, while in case of stellate and beluga sturgeons (Azov), from 80–100 to 100–130 lux.

#### **6.1.5 Important stages of postembryonic development**

The process of prelarval development is normally accomplished by gradual formation of organs

and systems and hence, during the normal growth of the organism. This period is characterized by alteration of larval organs (e.g. gill membranes being joined as a fold, outer gills, yolk deposition, etc.) to those typical of the adult stage. These processes are conditioned by some factors, as any deviation from the optimal conditions leads to disturbances in development and increases larval mortality. The traits of normal prelarval structure at different stages of development should be noted in order to differentiate pathological changes from normal developmental traits (Figure 90).

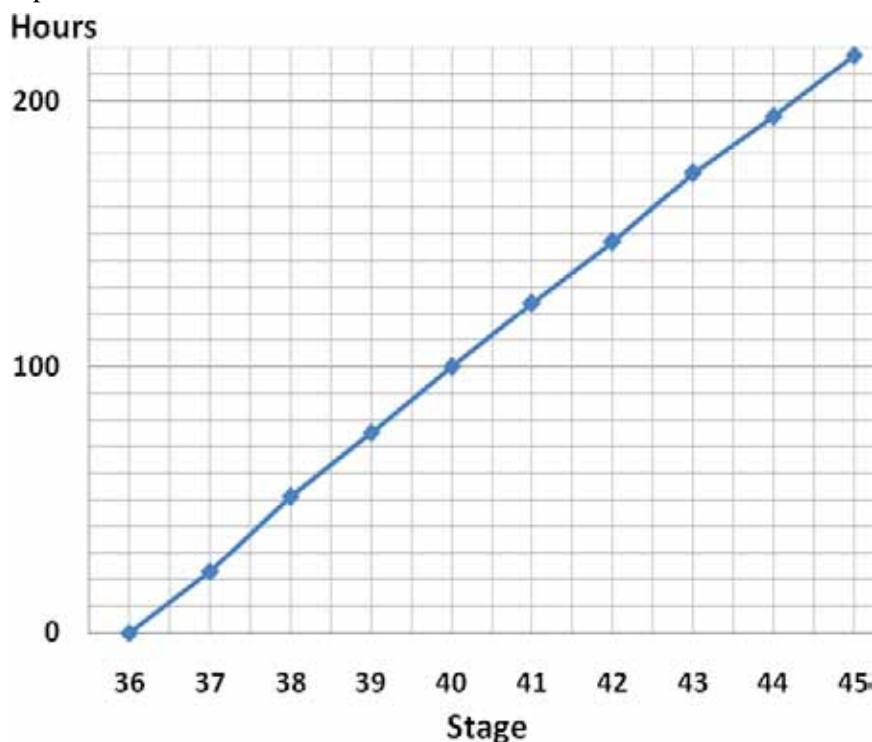
**Figure 90:** Evaluation of beluga development rate (stage 42).



During prelarval on-growing, special attention should be paid to such risky periods of postembryonic development as transition to branchial respiration and transition to exogenous feeding. Malformations in any of the mentioned systems or functions lead to prelarval mortality.

The time of onset of a given phase is water-temperature dependent. The chronology and peculiarities (stages) of sturgeon prelarval development are described in detail in Dettlaff, Ginsburg and Schmalhausen (1993) (Figure 91).

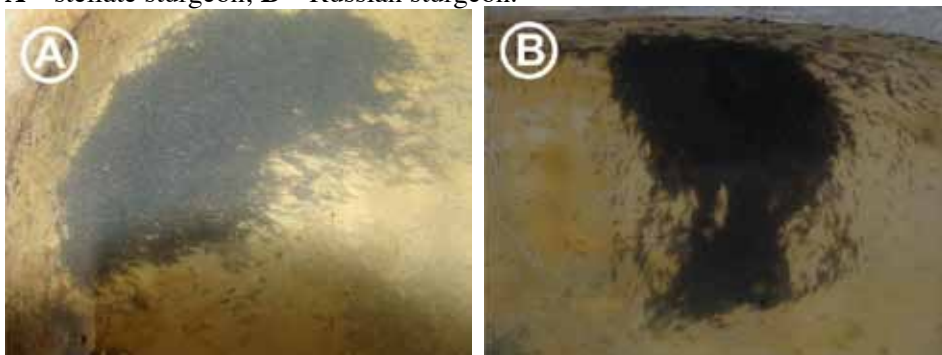
**Figure 91:** Duration of Russian sturgeon prelarval development from mass hatching (stage 36) until the onset of exogenous feeding (stage 45) at 18 °C water temperature.



### 6.1.6 Prelarval behavioural traits during the period of endogenous feeding

Some behavioural traits of larvae during the first days of life should be noted. After hatching, they disperse in the water column, making periodic movements up to the water surface and then drifting down to the bottom of the tank. During natural spawning, such a behaviour of sturgeon prelarvae lets them, firstly, avoid siltation and secondly, by running along the current, reach the zones with high concentrations of food organisms. At transition to branchial respiration and at the stage of alimentary system formation (during the so-called period of “swarming”), prelarvae are deposited at the bottom of the tank, forming swarms of different types. If these are located in the zones with poor water supply, mortality induced by oxygen deficiency may occur (oxygen consumption may be several times higher during this period as compared with embryonic development; for Russian sturgeon larvae at 1–52 d age, the oxygen threshold concentration was reported to range from 1.6 to 2.5 mg O<sub>2</sub>/liter, (Zhukinsky, 1986)). By this period, the intensity of oxygen consumption has increased several times as compared with that of the embryonic period, while exogenous feeding gradually stabilized during the fry period (Figure 92).

**Figure 92:** Typical behavioural response of sturgeon prelarvae – “swarming”: **A** – stellate sturgeon; **B** – Russian sturgeon.



It should be noted that prelarval behaviour during the period of their aggregation into “schools” is an indicator of prelarval hatchery quality. During the period of mass “schooling”, prelarvae that are swimming outside a “school” in the depth or on the surface of the water, feature, as a rule, various morphological anomalies.

The mass mortality of prelarvae at this stage also may be related to the hatchery quality of eggs and unfavourable rearing conditions. Upon reaching these stages, prelarvae with morphological defects such as developmental anomalies of the respiratory organs and/or digestive tract are not capable of further development and die. The overall mortality during the period of endogenous feeding should not be higher than 5–10 percent (depending on species). Therefore, sampling of prelarvae (30–50 live and dead individuals) should be performed every three days to control the development of the larvae and evaluate their quality (Figure 93).

**Figure 93:** Sample collected to assess quality of prelarvae.



During the periods of prelarval holding in tanks and egg incubation, it is essential to provide consistent control of seasonal temperature and oxygen conditions. The timely replacement of the filter screen at the outlet of the tanks is very important. In the course of prelarval growth, the mesh size of the outlet screen should be gradually increased from 1–2 mm at prelarval holding and transition to exogenous feeding to 7 mm at rearing of 10 g fry.

### **6.1.7 Functional peculiarities of prelarvae during the period of transition to mixed feeding**

The onset of mixed feeding is associated with initiation of taste receptors. The development of these receptors reaches a morphologically definite level at the end of this period. During the period of transition to active feeding, gustatory afferentiation plays a key role in the food-seeking behaviour of sturgeons (Devitsina and Gadzhieva, 1996).

The proper transition of prelarvae to exogenous feeding requires:

- well-developed sensory organs enabling response to the presence or movement of food organisms; and
- a mouth apparatus (capable of clenching the mouth; and a throat cavity connected to an esophagus) and digestive glands in the stomach and intestine that have reached a certain level of differentiation (Syтина and Timofeyev, 1973).

The functioning of the digestive system starts posteriorly. During the first days post hatch, tripsin appears in the spiral intestine of sturgeon larvae. Tripsin activity is elevated during the period of endogenous feeding. Stomach formation from the yolk sac is an important biological trait of early sturgeon ontogenesis. At the onset of exogenous feeding, pepsin can be found in the stomach (Sudakova, 1998), allowing utilization of simple proteins only. The increase in rate of successive stomach development is yolk-sac resorption dependent.

## **6.2 REARING OF LARVAE**

### **6.2.1 Transition to exogenous feeding**

Transition to exogenous feeding (stage 45) marks the completion of the prelarval phase of development and the onset of the larval stage, and is associated with changes in the respiration, metabolism, growth rate and survival of sturgeon larvae. At the onset of exogenous feeding, the cellular partition that closes the passage from the oral cavity to the gullet in prelarvae resolves and simultaneously the melanin (fecal) plug is extruded from the anal opening. These pigment plugs are visible as small black extrusions on the tank bottom. At the moment of initiation of exogenous feeding, prelarvae that have been in a quiescent state exhibit bottom grouping while searching for feed. In conventional hatchery protocol



(Dettlaff, Ginsburg and Schmalhausen, 1993), the appearance of single melanin plugs serves as an indicator to initiate first feeding, which should be performed at melanin plug extrusion in 2–3 percent of larvae. The period of melanin plug extrusion can take about 3–4 d. Untimely feeding may cause damage and loss of larvae; this is most characteristic for larvae of carnivorous sturgeon species (beluga and kaluga sturgeons). At the same time, past experience has shown that administration of feed in small doses stimulates the transition to exogenous feeding and significantly increases both survival ability of larvae and growth rates (Mironov, 1994). The opinion that melanin plug extrusion may not be a criterion for timing of feeding initiation has been expressed by Gisbert and Williot (2002b) and Williot et al. 2006 and Nekrasova (2006).

Ranges of prelarval length and weight at the onset of exogenous feeding are presented in Table 29.

**Table 29:** Length and weight of sturgeon prelarvae at transition to exogenous feeding.

Species	Weight, mg	Length, mm
Russian sturgeon	40–46	18–23
Stellate sturgeon	27–33	17–21
Beluga sturgeon	60–70	22–27
Ship sturgeon	25–35	13–17
Sterlet	19–21	13–15

The term of transition to exogenous feeding depends on the water temperature (Table 30).

**Table 30:** Duration of sturgeon prelarval development before transition to exogenous feeding in relation to water temperature.

Water temperature, °C	Duration, d		
	Russian sturgeon	Stellate sturgeon	Beluga sturgeon
12	20	–	18
13	18	–	16
15	12	–	12
17	9.5	12	10
19	8	9	8
21	7.5	8	7
23	–	6.5	–

Water supply to tanks should be increased up to 30 liter/min during the period of transition to exogenous feeding. Sharp variation in water temperature should

be avoided. Temperature drop, despite melanin plug extrusion, can cause refusal of larvae to feed due to a delayed process of fat resorption in the alimentary system (easily detected by examination of the abdominal area of larvae).

#### ***6.2.1.1 Developmental malformations during the period of transition to exogenous feeding***

During the period of transition to exogenous feeding, the number of dead specimens tends to increase, mostly due to mortalities of prelarvae having morphological defects. The most frequently occurring anomalies during the prelarval period are malformations (of functional, structural and mechanical character) in body shape, in external and internal organs etc. (see the more detailed description given in Section 9.5).

Mortality of sturgeon larvae at the transition to exogenous feeding is primarily due to poor quality of gametes and violations in biotechnological regime during embryogenesis (Semenov, 1965).

When evaluating progeny obtained from farmed broodstock or providing temperature-based control of seasonal reproduction (Galich and Chebanov, 2004), it is essential to assess not only the viability of this progeny, but to also consider the diversity in their quality and the character of morphological development. A comparative analysis of prelarvae, larvae and fry has enabled identification of several types of morphological abnormalities (Dettlaff, Ginsburg and Schmalhausen, 1993; Galich, 2000a; Akimova *et al.*, 2004). For example, disorders occurring during formation of the digestive system resulting from the influence of unfavourable temperatures include the following: retention of unchanged yolk mass, absence of fat droplets in the area of the mid-intestine as its formation is completed; absence of melanin in the spiral intestine, abnormalities in the formation of liver lobes, etc. Other types of abnormalities (e.g. underdevelopment or absence of the septum between the olfactory openings (nostrils) appearing in larvae are considered by many investigators to be of “hatchery origin”, allowing these to be regarded as natural tags that permit evaluation of the efficiency of artificial reproduction (Podushka and Levin, 1988). The appearance of such anomalies is associated with the negative impacts of different factors whose actions are intensified by elevation of temperature during the period of transition to exogenous feeding. It is important to note that similar malformations are not only a result of violating optimal conditions for development, but are also, probably, of a hereditary character (Chikhachev, 1996). This is why teratological analysis is an efficient and viable option for the ecological and morphological monitoring of sturgeon progeny.

#### **6.2.2 Feeding of larvae with live food**

It is common practice to use the following live foods in sturgeon larviculture to stimulate normal growth and formation of the digestive system during the first days of feeding: nauplii of brine shrimp (*Artemia*), small cladocerans

(*Daphnia magna*, *Moina macrocopa*), copepods (Copepoda), branchiopods (*Streptocephalus torvicornis*), rotifers (*Rotatoria*), chironomids (*Chironomus plumosus*), gammarids (Gammaridae), and minced oligochaetes (*white worms* – *Enchitreus albus*), tubifex (*Tubifex tubifex*) and Californian red worms (*Eisenia foetida*)) (Table 31). It is also possible to use eggs and larvae of trash fish for beluga feeding.

During the first days of transition to exogenous feeding, it is a good practice to lower the water level in the tank when administering live food, thus decreasing the energy expenditure of fry while seeking feeds and avoiding loss of live organisms with water draining from the tank. The feeding of larvae starts with nauplii of *Artemia*, minced oligochaetes and a small portion of zooplankton on the basis of 3–5 g of feeds per 1 000 larvae. It is very important to avoid overfeeding during the first days; thus small portions of feeds should be used. Considering that it is normal behaviour for sturgeon fry to rise to the water surface at night, it is recommended to feed them with zooplankton in the evening, while feeding with oligochaetes, etc. in the morning and afternoon.

The daily live food consumption rate (Table 31) is calculated by taking into consideration the target growth and feed conversion rates (*Artemia nauplii*, 3–4; *Daphnia*, 6; Oligochaeta, 2).

**Table 31:** The daily live food consumption rate.

Type of live food	Daily feed consumption rate, % of larval weight	
	Russian sturgeon, beluga sturgeon	Stellate sturgeon
<i>Tubifex</i>	30	20
<i>Other oligochaetes</i>	40–50	25–30
<i>Artemia nauplii</i>	60	40
<i>Daphnia, Moina</i>	80	60

*Tubifex* and other oligochaetes are fed in minced form (the amount depending on the fry weight) diluted with water and administered along the tank wall (perimeter) in two or three portions. When fed the correct quality and amount, Russian sturgeon larvae can usually reach 80–90 mg after 5–6 d, while stellate sturgeon can reach 50–60 mg during the same period. The subsequent feed ration is formulated taking into consideration the objective of the fry rearing and the biotechnology applied. Note that the prolonged exclusive use of live food (until weight of 0.1–0.15 g) is recommended only if further grow out of larvae in ponds is intended with subsequent release to the wild.

Frequency of feeding with live food depends on the rate of nutrient digestion, which is species specific. The rate of digestion of oligochaete worms and *Artemia* nauplii in Russian sturgeon is 1.5-fold less than in stellate sturgeon at the same temperature. This process takes 5–6 h on average, thus the daily ration for Russian sturgeon may be administered in four portions, while that for stellate sturgeon may be given in six to eight portions. Prior to each feed administration, silt, dead larvae and feed debris should be removed from the tank. This is essential for successful grow out of fry considering the important role of olfaction in sturgeon feeding.

The target yield of grow-out fry (Russian sturgeon, 80–100 mg; stellate sturgeon, 60–80 mg; beluga sturgeon, 100–120 mg; ship sturgeon, 100 mg) of standard weight for release in rearing ponds during the period of tank raising is not less than 70 percent.

The typical duration of larval rearing in tanks before transfer to earthen ponds is 7–10 d, depending on the water temperature. In order to correct the daily ration in each tank, the dead larvae are enumerated and subjected to teratological and morphological analysis. The control weighing is conducted once every five days for each tank in the course of growth rate observation and determination of the feeding rate.

### 6.2.3 Peculiarities of tank rearing of larvae intended for release into natural waterbodies

During the rearing of larvae intended for release into natural waterbodies, it is necessary to provide rearing conditions as close as possible to natural ones, thus enabling formation of behavioural responses (fitness characteristics) in hatchery-produced progeny. For larval rearing, it is better to use tanks with green (RAL 6019, 6027) or grey (RAL 9018) inner surfaces; white coloured surfaces should be avoided (Figure 94).

**Figure 94:** Unit for rearing of sturgeon fry: **A** – tanks; **B** – tanks and trays.



To increase the efficiency of environmentally friendly technology of sturgeon reproduction for hatchery stock enhancement (Tikhomirov & Nikonorov, 2000; Shcheglov, Mineyev and Vitvitskaya, 2000) allowing juveniles to be provided with appropriate “fitness” indices, it is important to provide:

- maximum enrichment by sensory informational (visual, tactile, hydrodynamic) rearing media in tanks at relatively low density as compared with the traditional density of larval stocking;
- natural photoperiod (Ruchin, 2007) at a higher level of illumination, corresponding to the species-specific peculiarities of sturgeons (Kasimov, 1987); (To decrease the negative influence of stressors while conducting hatchery operations (e.g. sorting, feeding) or fry rearing monitoring, it is wise to use red light);
- maintaining an astatic thermal regime with a diurnal amplitude of 4–5 °C or thermal gradient field to stimulate more intensive energy exchange and higher survival rate of fry (Konstantinov et al, 2005); (In accordance with the concept of ecological optimum, periodic (astatic) alteration in environmental parameters (e.g. light, temperature) within a certain range positively effects the growth and development of different sturgeon fry);
- holding of fry in thermal-light-colour gradient fields (Ruchin, 2007) optimizes energy inputs of fry via decreased feed conversion rate (FCR) and leads to 20–40 percent growth acceleration (as compared with constant conditions); Semenкова and Trenkler (1993) showed that a 16-h period of illumination was optimal, under which the weight of beluga fry (4-month-old) was 15 percent higher than at 24-h illumination.
- monochromatic illumination in the short-wave range to optimize fry growth and development; (Green light 16-h exposure (<800 lux) is most effective in the case of sturgeon fry (Ruchin, 2007)).
- creating water velocity in the tanks to enable development of swimming abilities of fry and improve the adaptive performance of their central nervous systems (Kozlov, Nikonorov and Vivitskaya, 1989; Nikonorov and Vitvitskaya, 1993); (The increase in swimming velocity of fry at elevated illumination should be noted.)
- providing stable background sound (avoiding sharp sound variations); (Excessive oxygen consumption is associated with shrill noise during the dark period (Bilio, 2007)).
- training of fry to survive in the natural environment, including development of adequate responses; (This can include putting predators into limited sections of the tanks or ponds, and training of timely avoidance response in larvae, fry and juveniles, as well as their acclimation to future environmental conditions (sudden changes in current , wave action, light, high salinity in coastal areas, etc.)
- application of different types of live food, especially at the onset of exogenous feeding to increase the level of thyroid hormones in the tissue due to inclusion of the hormonal “pool” of the live food (Boyko, Grigoryan and Chikhachev, 1993; Boyko and Grigoryan, 2002; Boyko, 2008); (This is tightly bound with the decrease in the frequency of morphological anomalies and formation of olfactory imprinting towards chemical

stimuli, and thus should determine future homing (returning to a native river) of ripe sturgeon breeders.)

- in connection with establishing olfactory imprinting in fry at the transition to exogenous feeding (Boyko, 2008), holding in water originating from the river intended for further release has preference; (The return of mature breeders to native rivers is one of the objectives of sturgeon hatchery enhancement projects; thus it is important to avoid holding prelarvae and larvae (in the first weeks of exogenous feeding) in ground water or water from other “nonnative” sources, despite any economic or other arguments (for instance, more favourable temperature).) and
- preliminary adaptation of larvae at early developmental stages towards water with 1–2 ppt salinity. (These fry exhibit higher growth rates and then higher survival in waters with high salinity.)

## 6.2.4 Tank rearing of juveniles for broodstock replenishment

### 6.2.4.1 A programme of different sturgeon juvenile feeding

When rearing fry destined for broodstock replenishment, the live food should be administered only during the first days after the transition of larvae to exogenous feeding. The long-term application of live food (especially of one prey species) is not feasible in terms of economic efficiency and can hamper the further rapid transition of fry to artificial feeds. Therefore, the portion of live food in the ration should be gradually reduced from 100 percent at day 1 of feeding to 5–7 percent by days 12–15.

**Table 32:** Feeding guidelines for Russian sturgeon (*A. gueldenstaedtii*) from fingerling size.<sup>1,2</sup>

Fish size, G	Min. feed rate, %BW/d	Max. feed rate, %BW/d	Feeding frequency, times/d	Pellet size, mm	Min. water temperature, °C	Max. water temperature, °C
10–30	3.50	5.50	10	1.5	15	22
30–75	2.50	4.00	8	2.0	15	22
75–200	1.70	2.80	6	3.0	15	22
200–700	1.00	1.60	4	4.5	15	22
700 – 1 300	0.45	0.80	4	4.5	15	22
1 300–3 000	0.25	0.50	3	6.0	15	22
3 000–5 000	0.20	0.40	2	6.0	10	22
5 000–10 000	0.20	0.35	2	8.0	10	22
10 000–15 000	0.15	0.30	2	8.0/10.0	10	22
15 000–20 000	0.12	0.25	1	10.0/12.0	10	22
> 20 000	0.12	0.20	1	12.0	10	22

<sup>1</sup> This feeding advice is a guideline only based on an optimal water quality and sufficient oxygen.

<sup>2</sup> BW = body weight.

The protein and lipid concentration ranges in larval feeds should be 50–60 percent and 9–16 percent, respectively (Ponomarev *et al.*, 2002). For accurate ration formulation, it is wise to follow the feed rations recommended by producers of special sturgeon compound feeds. A programme of different sturgeon juvenile feeding at optimal water temperatures that was developed by Coppens International bv (Netherlands) is given as an example (Tables 32–34).

**Table 33:** Feeding guidelines for beluga sturgeon (*H. huso*) from fingerling size.<sup>1,2</sup>

Fish size, g	Min. feed rate, %BW/d	Max. feed rate, %BW/d	Feeding frequency, times/d	Pellet size, mm	Min. water temperature, °C	Max. water temperature, °C
10–30	4.00	6.00	10	1.5	15	22
30–100	2.90	4.50	8	2.0	15	22
100–300	2.00	2.90	5	3.0	15	22
300–800	1.10	1.70	4	4.5	15	22
800–1 500	0.50	0.90	4	4.5	10	22
1 500–3 000	0.30	0.70	3	6.0	10	22
3 000–5 000	0.25	0.55	2	6.0	10	22
5 000–15 000	0.20	0.50	2	8.0/10.0	10	22
15 000–30 000	0.15	0.40	2	10.0	10	22
30 000–50 000	0.12	0.35	1	12.0	10	22
> 50 000	0.12	0.30	1	12.0	10	22

<sup>1</sup> This feeding advice is a guideline only based on an optimal water quality and sufficient oxygen.

<sup>2</sup> BW = body weight.

**Table 34:** Feeding guidelines for sterlet (*A. ruthenus*) from fingerling size.<sup>1,2</sup>

Fish size, g	Min. feed rate, %BW/d	Max. Feed rate, %BW/d	Feeding frequency, times/d	Pellet size, mm	Min. Water temperature, °C	Max. Water temperature, °C
10–50	3.15	4.50	10	1.5	14	22
50–100	2.20	3.00	8	2.0	14	22
100–200	1.45	2.00	6	3.0	14	22
200–800	0.75	1.15	4	4.5	14	22
800–1–500	0.35	0.55	4	4.5	14	22
1 500–3 000	0.20	0.40	3	6.0	8	22
3 000–5 000	0.15	0.30	2	6.0	8	22
5 000–8 000	0.12	0.25	2	8.0	8	22
> 8 000	0.12	0.25	2	8.0	8	22

<sup>1</sup> This feeding advice is a guideline only based on an optimal water quality and sufficient oxygen.

<sup>2</sup> BW = body weight.

#### 6.2.4.2 Feed particle sizes, daily rations and feeding frequency

The daily feeding rates for combined artificial feeds are age dependent and are thus calculated every 5–10 d, taking into account the temperature, average weight and fish number. The determination of mean weight is performed once every 5 d, starting from the onset of exogenous feeding. The quantity of fish should be specified, taking into consideration any dead fish. At transition to larger particle size, the larger pellets should be gradually mixed with those of previous sizes depending on juvenile size.

After each feeding delivery, checking of the feed consumption should be performed. If a large quantity of uneaten feed is recorded, the feeding schedule and the state of the fish should be checked. The daily rate should then be adjusted after determination of possible causes of the weak feeding activity.

Recommended frequencies of feeding and particle sizes are presented in Table 35.

**Table 35:** Relationship between particle size, frequency of feeding and fry weight.

Mean body weight, g	Diet particle size, mm	Feeding frequency, times/d
0.04–0.06	0.05–0.1	24
0.07–0.10	0.1–0.4	12
0.11–0.20	50% 0.2–0.4/50% 0.4–0.6	12
0.21–0.50	50% 0.4–0.6/50% 0.6–1.0	12
0.51–1.00	50% 0.6–1.0/50% 1.0–1.5	8
1.10–2.00	50% 1.0–1.5/50% 1.5–2.0	8
2.10–5.00	1.5–2.0	6
5.10–25.00	2.0	6
25.10–50.00	50% 2.0/50% 3.0	6
50.10–100.00	3.0–4.5	6

#### 6.2.4.3 Automation of the feeding process

Small automatic feeders (Figure 95) equipped with a control for regular supply of feed into the tanks have been routinely used at large hatcheries. After each feed administration, the rate of feed consumption should be monitored. If a considerable amount of uneaten feed is found, the technology of feeding as well as the state of the fish and the daily ration are checked for possible causes of weak feeding activity.



**Figure 95:** System of autofeeding.

#### 6.2.4.4 Control of feed consumption and fry sorting

In the process of grow out, the stocking densities and size structure of the sturgeon in each tank or tray should be monitored. Once the fry reach a weight of 0.2–0.3 g, due to increased feed competition, sorting should be performed every 10 d to separate three size groups: large, intermediate and small. When fry reach two months of age, sorting may again be necessary. The timely sortings allow:

- increased growth rate;
- decreased size variation of fry;
- improved FCR, hence better feed availability for fry; and
- decreased trauma associated with feed competition.

#### 6.2.4.5 Larval and fry stocking densities in tanks

Sturgeons are benthophagic fishes with an active feeding response. This is manifested through sharp body rotation, spinning and investigation of the feeding zone by the barbels; thus fry move closer to the bottom, reserving a circular bottom area with a diameter equal to their body length. For accurate determination of optimal larval stocking densities, the method based on the calculation of the average “feeding area” required by each larvae (equal to the area of a circle with a diameter equal to the average length of the larvae) is applied (Kupinskiy and Yanchenko, 2001). The stocking density of sturgeon larvae in tanks is species specific and depends also upon the initial larval weight and water temperature (Table 36).

**Table 36:** Stocking density for larvae, fry and juveniles in rectangular trays in nursery tanks.

Fish weight, g	Water temperature, °C	Stocking density, 1 000 individuals/m <sup>2</sup>	
		Russian sturgeon, stellate sturgeon	Beluga sturgeon
0.04–0.07	16–17	2.5	2.0
0.07–0.5	17–19	2.0	1.5
0.6–1.0	19–20	1.5	1.1
1.1–3.0	20–22	1.0–0.5	0.7–0.4
3.1–5.0	22–24	0.4	0.3
5.1–30.0	24–26	0.3–0.15	0.25–0.15

#### 6.2.4.6 Water demands in tanks

At the above-stated stocking densities in the open straight-through flow system, it is essential to provide a water supply to the tanks (4 m<sup>2</sup>) of up to 20 liter/min at transition to exogenous feeding, up to 30 liter/min at rearing from 0.5 to 1.0 g, and up to 50 liter/min at rearing up to 2–5 g. Oxygen content in this case should be above 6.0 mg/liter; concentrations under 3.0 mg/liter in winter cause fry death. The threshold concentration of ammonium should be as low as 0.05 mg/liter. Excessive free ammonia resulting from pH elevation during the process of fry rearing causes serious cases of autotoxicosis, which can manifest as gill necrosis and damage to the skin and fins and can lead to mass mortalities.

#### 6.2.4.7 Larval and fry growth rates

Approximate growth rates of different sturgeon fry at optimal temperature range (22–26 °C) and species-specific survival rates of 45–70 percent are shown in Table 37. In the course of artificial feed administration, it is essential to avoid accumulation of food debris and to provide daily cleaning of the tanks and proper maintenance of the hydrochemical regime.

**Table 37:** Growth rates of sturgeon fry in tanks at optimal temperatures.

Species	Body weight of sturgeon fry at age (d), mg							
	1	10	20	25	30	35	40	45
Russian sturgeon	20	40	100	250	450	1 000	1 600	2 500
Stellate sturgeon	10	30	70	150	250	600	1 000	1 500
Beluga sturgeon	30	70	140	350	650	2 000	3 500	4 000
Sterlet	8	20	45	90	180	550	1 000	1 500
Siberian sturgeon	17	35	80	180	330	1 000	1 700	2 800

### 6.3 FINGERLING REARING IN PONDS

#### 6.3.1 Pond dimensions

The rearing of fingerlings in ponds is the final phase of the combined sturgeon reproduction technology scheme of hatchery production – juveniles for restocking. Rearing of sturgeon fingerling involves the use of 1–4 ha ponds (optimal area – 2 ha) with a width/length ratio of 1:2 or 1:3, a depth of 2.3–2.5 m and a slightly sloping pond bottom. The pond bottom should be kept free of excessive vegetation (Figure 96). Fry that have out grown the culture tanks and trays are transferred into the rearing ponds. Mean weight of the fry (40–120 mg) depends on the standards for the species cultured. The fingerlings are transported in flasks or other water-filled containers.

**Figure 96:** Hatchery ponds for sturgeon fingerling rearing.



### 6.3.2 Preparation of ponds

The protocol for pond preparation comprises the following obligatory elements:

- pre-season preparation of the ponds (application of fertilizers);
- filling of ponds and establishing the natural food base for fry; and
- stocking and fry rearing.

Pond preparation for the next year should be initiated after the completion of the hatchery season. After the washing of the pond, its bottom should be kept clear of excessive vegetation and application of organic and mineral fertilizers with subsequent deep tilling should be performed (Anon., 1979). In spring, the ponds are subjected to discing and subsequent turning of the soil (Figure 97).

**Figure 97:** Ponds prepared for filling.

The inlet/outlet system should have sufficient delivery capacity to ensure rapid pond filling and target water exchange during 1–2 days. The pond ecosystem should be effectively protected to prevent entry of wild fish by using inlet screens or filters/mesh socks.

It is important to maintain an optimal water level in the ponds, avoiding its lowering, which causes unacceptably rapid development of filamentous algae, duckweed and other aquatic vegetation.

### 6.3.3 Larval stocking densities in ponds

The recommended stocking densities for the different species of sturgeon are given in Table 38.

**Table 38:** Standard larval stocking densities for different sturgeon species.

Species	Stocking density, 1 000 pcs/ha		Weight, mg
	Caspian Sea basin	Azov Sea basin	
Russian sturgeon	75	80	80–100
Stellate sturgeon	60	80	60–80
Beluga sturgeon	90	90	100–120
Ship sturgeon	70	75	60–80
Sterlet	50	60	40–60

It should be noted that the above stocking densities are recommended during the period of maximum supply of hatcheries by wild breeders. At present, it is a good practice to decrease these indices by 15–20 percent when rearing sturgeons in ponds. Pond rearing of juveniles prior to their release into natural waterbodies is an important transient phase that allows juveniles reared in “semi-wild” conditions to adapt to successive conditions in the wild. In fact, fingerlings held in ponds (a more complex and competitive environment) develop their feeding, defensive and other behavioural reflexes necessary in the wild more rapidly than fingerlings held in tanks (Kasimov, 1980).

#### **6.3.4 Establishment of feeding base and the application mineral fertilizers**

The prime feed items for sturgeon fry and fingerlings reared in ponds are different species of zooplankton (mainly Cladocera) and some benthic organisms (primarily *Chironomus* sp. larvae). The establishment of a food base ensuring the nutritional requirements of the fry should be performed following the existing methods by application of organic and mineral fertilizers. The application of mineral fertilizers (superphosphate –  $\text{Ca}(\text{H}_2\text{PO}_4)_x\text{H}_2\text{O}$  and ammonium nitrate –  $\text{NH}_4\text{NO}_3$ ) involves adjusting the nitrogen and phosphorus concentrations to 2 mg/liter and 0.5 mg/liter, respectively. During pond filling, when the water temperature is low, these parameters can be reached by application of 90 kg of ammonium nitrate and 90 kg of superphosphate per ha. At the second phase of pond filling, the amount of both fertilizers applied should be reduced to 60–70 kg/ha (Privezentsev and Lipko, 1987).

Besides mineral fertilizers, fodder yeast (10 kg/ha) and brood culture of *Daphnia* (5–10 kg/ha) should be introduced along the edges of the ponds to accelerate phyto- and zooplankton development. In addition to fodder yeast, the development of bacteria (feed for zooplankton) may be stimulated by introduction of an organic fertilizer such as rotting vegetable matter (introduced once during the entire grow-out period) (Zaikina, 1975).

The consistent feeding potential should be maintained in the ponds throughout the entire period of rearing. It is wise to apply fertilizers on a regular basis: every 8 d during the first cycle of rearing and every 15 d during the second cycle. The amount of fertilizers to be applied should be determined considering the target levels of nitrogen (2 mg/liter) and phosphorus (0.5 mg/liter). On average this requires application of ammonium nitrate and superphosphate at the rates of 3–5 kg and 2–6 kg per 1000 m<sup>2</sup>, respectively.

The optimal biomass of feed organisms in the ponds is as follows: plankton – above 3 g/m<sup>3</sup> and benthos – above 5 g/m<sup>2</sup> of bottom area. Note that the daily ration of fry during pond rearing increases from 25 percent of the body weight for 20-d-old fry to 36 percent for 40-d-old fry (Krupiy and Kolodkova, 1996).

#### **6.3.5 Methods for elevation of the food base**

In addition to the application of fertilizers, it is also recommended to perform a series of measures aimed at increasing the biomass of food organisms in the ponds and the reconstruction of their species composition, including:

- step by step filling of the ponds with additional fertilization and introduction of broodstock of *Daphnia*;
- introduction of necto-benthic organisms (gammarids: *Gammarus pulex*, *Pontogammarus robustoides*, *Dikerogammarus haemobaphes*, *Niphargoides maoticus*; and misids: *Paramysis lacustris*, *P. ullskyi*) collected along the coastal areas of the Azov, Black and Caspian seas, at future sites of fingerling release and nursery grounds; and
- increase in abundance of basic feed organisms.

#### **6.3.5.1 Misidler (*Mysidacea*) ve gammaridler (*Gammaridae*)**

Misids and gammarids are the best choice for hatchery culture. As food for gammarids, planktonic algae: protococcus (*Scenedesmus*, *Pediastrum*, *Oocystis*, *Chlorella*), diatoms (*Stephanodiscus*) and cyanobacteria (*Merismopedia*, *Comphosphaeria*) predominate, while misids prefer organic detritus, which favours their introduction into sturgeon ponds.

Bu organizmaların damızlık kültürleri; nisan- haziran döneminde yumurta verimA brood culture of these organisms can be collected in low-salinity sea areas with sand-shell soils from April to June, as during this period the previous year's individuals with high fecundity can be found in the population.

Gammarids should be transported in wooden boxes without water in wet aquatic vegetation. Misids are transported in live fish tanks or plastic bags with water and oxygenation.

The normal stocking rate of introduced organisms is 0.3 kg/ha for misids and 0.5 kg/ha for gammarids (Vorobyeva and Nikonova, 1987). Note that the introduction of these organisms into the ponds compensates to considerable extent for the lack of available sturgeon fry feeds during chironomid hatching. Moreover, high survival rates and low mortality during overwintering are important traits of the introduced benthic crustaceans. Misids are capable of overwintering in dried areas of the pond bottom. Along with the introduction of benthic crustaceans into the ponds, it is essential to culture them directly in a pond or in small cages made from caprone sieve No. 7 with a volume of 3–4 m<sup>3</sup> or in baffled-off parts of the pond. The stocking density of misids in a cage amounts to 15 000/m<sup>2</sup>, while that of gammarids is 1 500/m<sup>2</sup>. The best feeds for crustaceans in the cages are ground algae (*Oedagonium* sp.) and hydrolytic yeast.

#### **6.3.5.2 Chironomids (*Chironomidae*)**

The quantity of chironomid larvae, which are the prime feed preference of sturgeon fry, can be considerably elevated by mounting of additional surface made of fine-mesh net, plastic, etc. fixed on 3 x 3 m frames. Typically, 25–30 g of chironomids will settle on 1 m<sup>2</sup> of the surface and produce a biomass of 150–180 g during the spring-summer period. Additionally, vertical surfaces made of polyethylene film can be placed on the rectangular frames. The strips of film



are placed on the frame at 10 cm intervals; thus 250 m<sup>2</sup> of extra surface can be placed on one 3 x 3 m frame.

### **6.3.5.3 Branchiopoda (*Streptocephalus torvicornis*)**

An effective method of increasing the feed base in the ponds entails the introduction of brachiopods (*Streptocephalus torvicornis*), which have proven to be an effective feed for sturgeon fry, especially beluga sturgeon. To accomplish this, silt containing a great deal of eggs (180–200 eggs/m<sup>2</sup>) is collected from waterbodies where *Streptocephalus* is abundant and evenly spread along the bottom of the hatchery ponds. Production of *Streptocephalus* in the ponds during fry rearing can reach 84 000 individuals/m<sup>2</sup>. The algal and yeast cultures may be used to feed *Streptocephalus*. The collection of *Streptocephalus* eggs from natural waterbodies is also possible. The collected eggs should be dry and any impurities removed by using sieves.

## **6.3.6 Extermination of phyllopods (Phyllopoda)**

### **6.3.6.1 Conventional methods**

Phyllopods occurring in the ponds suppress the development of sturgeon fry, resulting in a sharp decrease in their abundance due to feeding competition. In some cases, fry can be eaten by phyllopods. Moreover, phyllopods living on the bottom areas of ponds can stir up silt, strongly reducing water transparency and thus causing a sharp drop in the efficiency of photosynthesis leading to mortality of prime feed organisms (chironomids and cladocerans).

Traditionally, various toxic preparations have been used to exterminate phyllopods. The most effective of these is chlorine thiosulfate, which destroys juveniles of tadpole shrimp (*Lepidurus apus*) at a concentration of 1 mg/liter active chlorine, *Leptosteria* sp. at 1.4 mg/liter and all adult phyllopods at 1.7 mg/liter. Note that obligatory conditions for the effective use of chlorine thiosulfate are the compulsory filling of ponds at target levels and the disperse application of this preparation to the entire water surface. Chlorine thiosulfate is applied to ponds 6–9 d after filling of ponds. The rate of application is 13–15 kg per 1 000 m<sup>2</sup> when using a special chlorinator (a boat with installed bin) (Askerov and Sidorov, 1964). The shortcoming of this approach is the incomplete extermination of pests. Moreover, despite the short duration of the toxic effect of chlorine thiosulfate (less than 48 h), the feed potential recovers only in 10–15 d.

### **6.3.6.2 Environmental methods for phyllopod extermination**

Some environmentally sustainable approaches to phyllopod extermination have recently been elaborated:

- In “provocative filling”, the pond is filled to one third its volume and then drained after mass hatching. In applying this technique, it is important to prevent the laying of new eggs by phyllopods; thus the method is not

always effective (Askerov and Sidorov, 1964). Moreover, this method requires considerable water demand and may not be economically expedient for hatcheries with mechanical water supply.

- To reduce the negative effect of phyllo pods on the growth performance of sturgeon fry, the method of step by step filling of the pond may be used with phyllo pods as feed for sturgeon fry. In this case, introduced fry of Russian and stellate sturgeons should not weigh less than 100–120 mg. Stocking should be initiated immediately after the hatching of leptoster (Leptostheria) or tadpole shrimp (*Lepidurus apus*) at one third of the target water level in the pond. In the course of the phyllo pods being consumed by the fry, the ponds should be filled to half of their volume and then completely.

In order to maintain intraspecific structure and create adequate environmental conditions (e.g. thermal regime, photoperiod, feed potential), for all sturgeon species, it is essential to conduct fingerling rearing in ponds in several cycles during the entire rearing season, including:

- possible early stocking of ponds (20–25 d earlier) by obtaining fertilized eggs and growing fry before the onset of spawning temperatures by using thermoregulation (Kokoza, 2004). This allows use of the pond feed base potential to its full extent and considerably widens the range of prey available to fry;
- stocking during the traditional period (late May–June); and
- stocking during cycle II after the summer peak of temperatures (mid-July to mid-August)
- with larger fry (1–2 g) at lower stocking densities (10 000/ha).

Stocking of ponds outside of the traditional periods allows for more efficient utilization of hatchery production facilities and avoids rearing of juveniles during the summer temperature peak, creating favourable conditions for growth and development, and hence increases survival rates in ponds and the sea. The feed base state and fry growth rate should be monitored throughout pond rearing. The control of pathogens is also important. Once the fry reach the standard weight (Russian sturgeon, 2–3 g; stellate and ship sturgeons, 1.5–2.5 g; beluga sturgeon, 3–4 g; sterlet, 1.5–2 g), water discharge from the ponds and fry release into natural waterbodies can be initiated. The mean survival rate of juveniles during the 30–40 d period of pond rearing is 50 percent.





## Chapter 7

### Production of live food

#### 7.1 INTRODUCTION

The production and use of live food for aquaculture has been described in detail by Lavens and Sorgeloos (1996). The conventional methods of live food production used in the hatcheries of the Azov and Caspian basins are given below. Culture of live food requires the set up of special areas at the hatcheries.

#### 7.2 CULTIVATION OF OLIGOCHAETES (*ENCHYTRAEUS ALBIDUS*)

The cultivation of oligochaetes in sturgeon hatcheries calls for a special air-conditioned premises with a constant (year-round) air temperature of 16–20 °C. The facility must be equipped with water supply lines and a sewage system and include a unit with racks (stands) for the boxes (Figure 98), as well as a room to separate the worms from soil, a refrigerated chamber (for the storage of products) and a feeding kitchen for preparation of feed mixtures.

**Figure 98:** Boxes for oligochaete culture in special facility (unit).



The cultivation of white worms (*Enchytraeus albidus*) is carried out in wooden boxes, which measure 0.5 x 0.4 x 0.12 m. A mild soil that has been sieved (3–5 mm mesh size) and mixed with humus (e.g. garden soil) may be used as the substrate, the humidity and pH of which should be maintained at 22–26 percent and 6.2–6.8, respectively. The norm for broodstock culture loading is 0.2–0.25 kg/m<sup>2</sup> (40–50 g per box) on a 3–4 cm soil depth. The optimal temperature for worm growth, development and propagation is 16–18 °C. At this temperature, egg development takes 7 d; then in 4 d hatched juveniles leave their cocoons and start exogenous feeding. Worms reach maturity at 21–23 d and reach a weight

of 6–9 mg. In sturgeon hatcheries, the nourishment is provided in the form of feed mixtures composed of the wastes of flour, beetroot, bran, cabbage, garden leaves, potatoes and other carbohydrate-rich vegetables, screenings, fodder yeast, and plant roughage. The mixture is cooked and passed through a chopper. The feed mixtures are given in the form of a liquid puree or a dough. The fodder yeast is given in the form of a solution (1 kg of yeast per 4 liter of water). Feeding is given once a week by laying the feeds into the 4–6 cm furrows and covering them with soil. The ration is calculated on the basis of worm biomass and FRC. The FRCs for vegetables, flour wastes and yeast are 6, 4.5 and 1, respectively. The following diet composition was recommended for oligochaetes: vegetables – 60 percent, flour wastes – 20 percent and baker's yeast – 20 percent. During the first month of oligochaete culture, they show a 2-fold growth of population biomass. Successive culturing allows a 5-fold increase in biomass. The optimal density of white worm cultivation is 750 g/m<sup>2</sup>, while the maximum is 1 500 g/m<sup>2</sup>. Harvesting is performed at a biomass of 750 g/m<sup>2</sup>, which allows weekly collection of 400 g of worms from 1 m<sup>2</sup>.

For collection of white worms, the troughs with soil should be placed under bright light and warmth from incandescent lamps. Escaping from the light, the worms accumulate on the bottom of the dish, where they are collected and any soil is removed. The harvest density of oligochaetes averages 420 g/m<sup>2</sup> weekly. The residual ground after worm collection, which contains a great deal of cocoons with eggs, is poured back into the boxes from which it has been taken.

In addition to the above mentioned feeds, during the past decade dry feeds have been used for feeding oligochaetes at some sturgeon hatcheries. For instance, Memiş, Çelikkale and Ercan, (2004) reported on five diets: carbohydrates, vegetables, fruits, pelleted commercial trout feed, and a combination of all four. Highest increase in numbers and best reproduction occurred with the pelleted commercial trout feed.

### **7.3 CULTIVATION OF CLADOCERANS (DAPHNIA, MOINA)**

#### **7.3.1 General requirements**

The live prey organisms cultured in sturgeon hatcheries also include cladocerans (*Daphnia magna*, *D. pulex*, *Moina rectirostris* and *M. macrocopa*), which feature high rates of growth, fecundity and survival. Because of their small size, *Moina* (juveniles of 0.2–0.4 mm, adults of 1.5 mm) are the most suitable prey for the prelarvae in the first days after transition to exogenous feeding. The technological basis for the cultivation of cladocerans is the creation of favourable conditions in a separate unchangeable volume of water (Bogatova, Tagirova, and Ovchinnikova., 1975). For this purpose, any concrete (12 x 3–4 m) or plastic tanks or trays of at least 2 m<sup>3</sup> in volume and at most 50–60 cm in depth are suitable. These are placed, depending on climatic conditions, in an open well-sunlit place or indoors (Figure 99).

**Figure 99:** Concrete tanks for cladoceran (*Daphnia* and *Moina*) culture.



Before broodstock stocking, mineral fertilizers are applied to the tanks at the rate of  $37.5 \text{ g/m}^3$  of ammonium nitrate or  $65 \text{ g/m}^3$  of ammonium sulphate. To provide for the rapid development of planktonic crustaceans, additional feeds are introduced into the tanks. The daily rate of nutrients is as follows: *Chlorella* – 200 million cells/ $\text{m}^3$ ; yeast –  $10\text{--}15 \text{ g/m}^3$  in the form of a suspension (2 liter/ $\text{m}^3$  of water); horse manure –  $0.8\text{--}1.5 \text{ kg/m}^3$ ; ammonium nitrate –  $18.75 \text{ g/m}^3$ ; and ammonium sulphate –  $32.5 \text{ g/m}^3$ . The nutrients are added along the walls of the tanks every day or once per 8–10 d. The intensity of development of protococcal algae (the primary feed of Cladocera) is controlled by visual examination of the colour of the water. Bright green nontransparent water colour indicates a maximum density of algae. Once this has occurred, the application of fertilizers should be stopped. An increase in transparency bears witness to a reduction in food potential and signals the need to resume fertilization.

### 7.3.2 Culture conditions

The rate of broodstock maturation depends significantly on the introduced broodstock. At  $10 \text{ g/m}^3$  stocking density, the culture achieves the maximum in 15 d, while at  $100 \text{ g/m}^3$  – in 10 d. The amount of dry yeast consumed during the cultivation of 1 kg of Cladocera amounts to 200–300 g. Should the rapid need for live food arise, the maturation period may be considerably reduced at the cost of higher rates of broodstock introduction (Table 39). The optimum conditions for cultivation are: degree of hardness (odH), 6–18°; pH 7.2–8.0; temperature, 20–24 °C (*Daphnia*), 24–30 °C (*Moina*); oxygen demand, lower than 50–70 mg  $\text{O}_2$ /liter; and carbon dioxide ( $\text{CO}_2$ ), lower than 10 mg/liter.

**Table 39:** Recommended volume of introduced inoculum of mature *Daphnia* sufficient for target daily harvest 0.2–1 kg of live *Daphnia* from the tank (after Askerov and Sidorov, 1964).

Daphnia broodstock introduced into the culture (kg/m <sup>3</sup> )	Days of culture until first harvest
0.5	10–12
1	8
2	5–6
3	3–4

Once a ratio of 50 percent adult and 50 percent juvenile *Daphnia* is reached in the tanks, the culture may be considered as ripe. At this point, a 30–35 g/m<sup>3</sup> harvest can be collected daily.

### 7.3.3 Nutrient value enhancement

The Cladocera are sieved with the use of fine-mesh screen scoops and fed immediately or frozen in the cellular troughs, in order to retain the nutrient value of the feeds.

The method of bioencapsulation by bacteria (*Saccharomyces cerevisiae*) is used to enhance the nutritional value of *D. magna* (Jafaryan, Alimohamady and Makhodomi, 2009). For instance, prior to feeding of Persian sturgeon (*A. persicus*), *D. magna* was held in bacterial suspension for 10 h. The highest larval growth rate was recorded when a suspension of 10<sup>8.48</sup> (CFU/liter) concentration was used.

## 7.4 CULTIVATION OF ARTEMIA SALINA

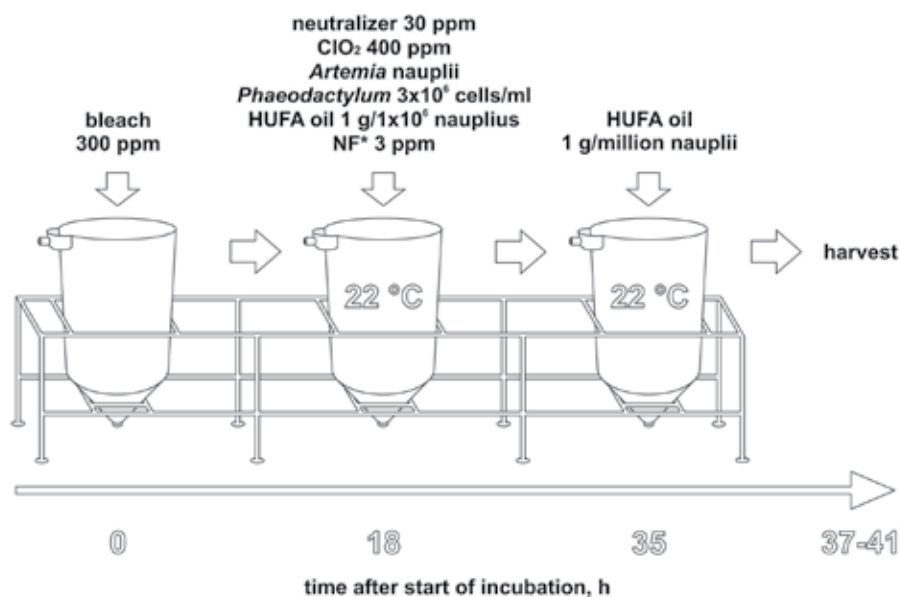
### 7.4.1 Incubation of *Artemia* cysts

The incubation of *Artemia* cysts calls for the use of transparent cylindrical-conical tanks of 40 to 300 liter capacity. High oxygen content and the mixing of eggs in the apparatus are accomplished by aeration of the water by the use of a compressor, the sprayers of which are mounted in the bottom part of the apparatus. Artificial illumination above the apparatus should be constantly provided. For incubation, the activated eggs are placed into a 4–5 percent salt (NaCl) solution. The density of eggs should be 4–5 g/liter. The temperature in the incubation apparatus must be maintained at 27–29 °C. Under these conditions, the nauplii hatch 24–30 h after the eggs are loaded (Litvinenko *et al.*, 2000). Upon the completion of incubation, the light and compressor are switched off for 15 min. As a result, hatching occurs and the nauplii concentrate in the lower part of the system. The dead nauplii and any nonhatched eggs are then discharged through a drain cock and the nauplii then poured off into the harvesting net (114 μm mesh). The nauplii that are obtained are either fed immediately or placed into the tanks with 3–5 percent salt solution for further growing or freezing (Litvinenko *et al.*, 2000).

### 7.4.2 Bioencapsulation of *Artemia* nauplii

To reduce the FCR and increase survival and larval growth rates and stress resistance, it is necessary to apply the method of *Artemia* nauplius enrichment with  $\omega$ -3 highly unsaturated fatty acids (HUFA) (Lavens and Sorgeloos, 1996; Noori, Azari Takami and Sorgeloos, 2002; Hafezieh *et al.*, 2009) (Figure 100).

**Figure 100:** Layout for *Artemia* nauplius enrichment (modified from Çiftci *et al.*, 2002). (\* NF = sodium nyfurstyrenate acid)



The technique of *Artemia* nauplii bioencapsulation with probiotics has also been applied in order to enhance growth rate and sturgeon larval quality. Before feeding of larvae, *Artemia* nauplii are held for 10 h in bacterial suspension (*Bacillus licheniformis*, *B. subtilis*, *B. polymixa*, *B. laterosporus*, *B. circulans* – commercial name “Protexin aquatic”). The best results at feeding of *A. nudiventris* larvae by bioencapsulated *Artemia urmiana* nauplii (Jafaryan, Makhodomi and Pordelan, 2009) were recorded with the use of bacterial suspension at 3x10<sup>5</sup> bacteria/ml (CFU/ml).

### 7.4.3 Cultivation of *Artemia* in tanks

Culture of *Artemia* nauplii and large brine shrimp can be performed in nonfilterable tanks (Figure 101) similar to those used for cladoceran culture but made of salt-resistant concrete or plastic. Cysts (500–600 g/m<sup>3</sup>) or adult *A. salina* (10 g/m<sup>3</sup>) are introduced into the stocking tanks with 40–50 ppt salinity. In the wild, the primary food of *A. salina* is microalgae (*Dunaliella salina*) as well as benthic bacteria and detritus. A *Chlorella* culture (1 million cells per ml) and diluted chemicals (0.1 kg of Glauber’s salt, 0.05 kg of potassium nitrate, 0.05 kg of superphosphate – all

per  $1 \text{ m}^3$ ) are introduced into the tank to stimulate the development of protococcal algae. Diluted baker's yeast applied to the tank at a rate  $0.01 \text{ kg/m}^3$  can be also used as an *Artemia* feed. Starting from the third day after hatching of nauplii, yeast is applied every 5 d at a rate of  $20 \text{ kg/m}^3$ . When the *Artemia* reach maturity, the frequency of feeding is once every 3 d, while during their mass reproduction, the feed ration for broodstock should be increased to  $35 \text{ kg/m}^3$ . The holding conditions and feed availability for *Artemia* can be assessed visually on the basis of their behaviour. The uniform distribution of *Artemia* in the water column indicates normal ambient conditions, while bottom and wall crowding of *Artemia* indicates insufficient availability of feeds. Upwards concentration and slow locomotory activity are evidence of oxygen deficiency. Collection of *Artemia* should be initiated when the ratio of immature to mature specimens is 1:10 or lower. In this situation, the acceptable standard of culture harvest is  $1/3$ – $1/2$  of all biomass or  $100$ – $120 \text{ g/m}^3$ . In order to achieve sustainable harvest, it is essential to maintain stable salt and dissolved oxygen (not less than  $4 \text{ mg/liter}$ ) concentrations in the tanks, thus ensuring naupliar hatching. After completion of the hatchery season, eggs of *Artemia* can be preserved in tanks for overwintering.

### 7.5 CULTIVATION OF CALIFORNIAN RED WORM (EISENIA FOETIDA)

Californian red worm (*Eisenia foetida*) has been effectively used for the feeding of sturgeon juveniles (Labenets and Nikiforov, 1999). Plastic trays of  $0.2$ – $0.3 \text{ m}$  height may be used for worm culture. These trays are typically placed on racks (Figure 101).

**Figure 101:** Californian red worm culture unit (Atyrau Sturgeon Hatchery, Kazakhstan).



---

The substratum for cultivation of worms is prepared from fermented manure, garden soil, chopped straw or other cellulose-containing material. Thereafter, the substratum is moistened and stocked with the worms at a density of 5 000 individuals per m<sup>2</sup>. The cultivation proceeds at 6.5–7.5 pH, humidity of 75–80 percent and a temperature of 22–23 °C. Upon stocking of the worms, the trays with substratum are covered with the straw or rush mats to retain the moisture of the soil.

A UV-radiation source is necessary to hold the worms in the substrate. To accomplish this, mercury-discharge lamps are installed in the greenhouse. The substratum is systematically moistened. As it settles (through the eating of organic matter by the worms), it is supplemented as needed up to the level of the edges of the trays. The cultivation cycle lasts for 90–120 d. During this time, the number of worms increases to 30 000–40 000 individuals per m<sup>2</sup>, the biomass reaching 9–12 kg/m<sup>2</sup>. For two cycles of cultivation annually, the biomass amounts to 18–25 kg/m<sup>2</sup>. As the culture cycle is completed, the substratum with worms is dried to 50–60 percent humidity, and the substratum and worms are separated. Ground worms may be also fed to the juveniles in dried or boiled form.





## Chapter 8

### Artificial reproduction of sturgeons based on the control of seasonality

#### 8.1 INTRODUCTION

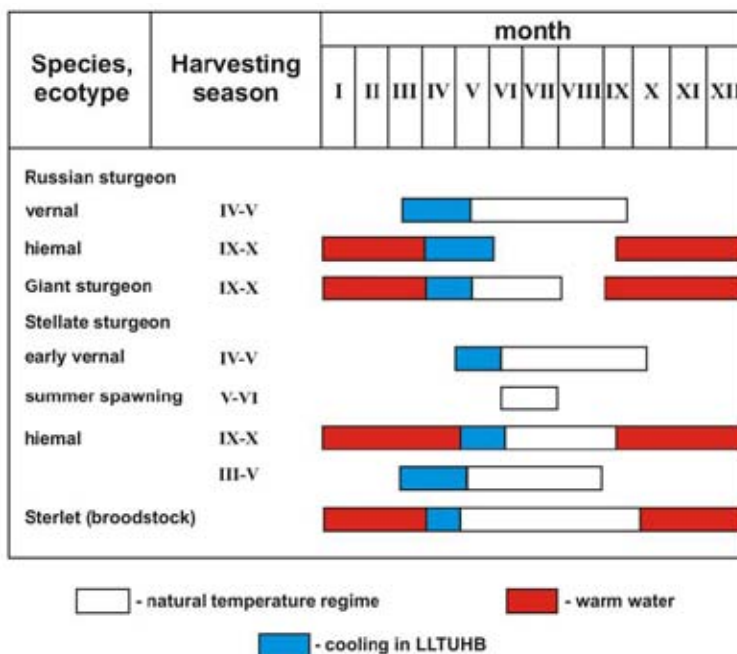
Alteration of water regimes in spawning rivers and the transition to artificial reproduction have caused considerable changes in the specific and interpopulational structure of sturgeon broodstocks, negatively affecting genetic diversity. Since sturgeon stock abundance depends on the results of artificial reproduction, the associated biotechnology should be focused on rebuilding of populations and restoration of their natural genetic diversity (Barannikova, 1970, 1979). The loss of natural heterogeneity has been attributed primarily to the fact that the goal of sturgeon hatchery stock enhancement is the “gross” release of fingerlings. Such an approach necessitates that the most reproductively mature part of the sturgeon stock (i.e. of the first spawning run) should be used for reproduction and leads to the decrease of environmental and evolutionary plasticity of species (Kazansky, 1975; Barannikova, 1975).

Traditional technologies for artificial reproduction are limited by the short period of anadromous migration and the physiological status of breeders, which does not enable prolonged preservation of their functional maturity. Extensive experience in the exploitation of a long-term low temperature unit for holding broodstock (LLTUHB) in the Volga River delta (Kazansky and Molodtsov, 1974) has shown that individuals belonging to the early “vernal “ (spring race) of Russian sturgeon from the Caspian population being held at complete maturity stage IV exhibited a sexual cycle that was shifted to a later period by up to three months. Available methodology frameworks did not ensure the stable hatchery effect at fish transition to spawning state. Additionally, the biological status of the spawning part of the population had been transformed considerably in response to changes in the environmental conditions of migration. That is why LLTUHB has not been implemented at sturgeon hatcheries of the Sea of Azov despite the special importance of the application of novel biotechnologies.

The development of different methods for the ecological and hormonal regulation of seasonal propagation (e.g. for stellate, Russian and beluga sturgeons and sterlet) has enabled the technological feasibility (with the use of LLTUHB) (Figure 102) for shifting the reproductive cycle of different races, as well as of domestic breeders, to earlier or later spawning (up to 5 and 6 months, respectively) (Chebanov, 1996a, Chebanov, 1997), with a resulting high performance of broodstock, especially of the summer-spawning stellate sturgeon.

**Figure 102:** Unit for long-term holding of broodstock at low temperatures.

Moreover, the obtaining of ripe gametes from hiemal migrants and the rearing of viable fry under controlled temperature conditions enable the early obtaining of progeny originating from wild sturgeon breeders (Figure 103), permitting the optimization of production areas and ensuring prolonged release of different size-graded fry into natural waterbodies.

**Figure 103:** Scheme of year-round reproduction of different sturgeon species and ecotypes.

Specific biotechnology includes the following elements (Chebanov, 1996b):

- extended holding of sturgeons at a constant (prespawning) temperature regime that varies depending on species and race;
- transition of fish to the appropriate spawning temperature regime based on the system of temperature variation and duration corresponding to the holding of sturgeons of the particular species and race;
- seasonal variation of combined use of the system: warmwater ponds – LLTUHB;
- shift of the sexual cycle of wild hiemal sturgeon breeders to earlier season by using warm water;
- obtaining autumn, winter or early spring offspring from autumn-run migrants;
- updated scheme of hormonal stimulation of gametes depending on the conditions of collection and utilization of sturgeon breeders;
- timing of the temperature regime for egg incubation and adaptation of larvae obtained outside the traditional season;
- automated control of temperature regime and water supply, as well as control of other environmental parameters;
- addition of an egg incubation unit with connection to the water supply system into the scheme of LLTUHB;
- use of extra water reservoirs for water intake from rearing tanks in order to reduce time losses associated with refilling of tanks after operations with breeders; and
- use of a filtration system for water purification at the LLTUHB inlet and water recirculation systems.

## 8.2 COLLECTION OF BREEDERS

Collection of sturgeon breeders destined for long-term holding in indoor facilities is performed in the sea using trap nets or in the river using harvesting nets at low temperatures:

- 5–15 °C – Russian sturgeon;
- 7–16 °C – early vernal stellate sturgeon;
- 17–20 °C – late vernal/summer-spawning stellate sturgeon; and
- 12–16°C – hiemal stellate sturgeon.

One of the key elements of holding sturgeon breeders at the LLTUHB is their accumulation in an indoor unit with three to nine tanks with 30–40 m<sup>3</sup> capacity.

### 8.2.1 Methods for accumulation of wild breeders

Accumulation of wild breeders in a LLTUHB is typically complicated by its remote location from collection sites and by the small number of fish that are delivered to the facilities as one lot. For this reason, the rapid stocking of all the tanks during two to three days is usually impossible; typically it takes five to ten days. In this case, it is important to perform stocking of fish in the tanks under conditions that enable their adaptation to long-term holding. There exist four methods of fish loading into the tanks and transition to a constant regime of holding (CRH):

1. holding of fish at natural temperatures without the use of cooling equipment until full stocking of the tanks and exposure to CRH;
2. setting of the target CRH after loading the first batch; all further batches are kept (considering the period of adaptation to new temperature – 3 h) until reaching the target temperature in the special unit, whereupon fish are transferred to the CRH;
3. holding of fish at wide temperature variations until full stocking of tanks and transition to the CRH; and
4. after the filling of one or two tanks, the unit should be exposed to CRH. The empty tanks should be excluded from the recirculated water system (i.e. not supplied with cool water); only after full stocking of the tanks will they be connected to the cooling system.

Application of the first approach requires the holding of mature breeders (complete maturity stage IV) in tanks at considerably elevated temperatures (e.g. Russian sturgeon, 11–13 °C, stellate sturgeon, 13–17 °C) over 24 h, which can lead to formation of blisters and body and gill haematomas due to the active behaviour of fish at spawning temperatures. The process of adaptation is complicated by a worsening of their physiological state, whereas preventive measures will provoke a new stress and critical changes in the state of the breeders, necessitating their removal from the tanks. In this case, 30 percent or less of the withdrawn breeders are subjected to CRH.

A prerequisite of the second method is the frequent transfer of breeders from one indoor unit to another. This also leads to exposure to stressors and complicates the adaptation of fish to long-term holding in the tanks. Using this method, 30–35 percent of the fish are able to retain their reproductive capacity until the target date.

The third method avoids transfer of breeders from one unit to another and therefore maintains their initial physiological state, as fish can easily tolerate a wide variation in temperature (as is typical in the wild) (Rivkin and Kazansky, 1979). The adaptation to new environmental conditions is permanent. In this case, the overall mortality rate is not higher than 5–8 percent throughout the period of holding (1.5–4 months).

Evaluation of fourth method has demonstrated that after a fast connection to the cooling system, a sharp decrease in temperature is observed in the tank:

the negative temperature gradient can reach 6 °C during 1–1.5 h. Therefore, this method requires a more detailed scheme for integration of isolated tanks into the cooling system and obviously might be more promising for units with an increased number of tanks.

The period of fish post-stress adaptation (related to their capture and transportation) is rather long (14 d). Thus, during stocking and the subsequent holding of breeders, the transfer of fish from tank to tank should be avoided. This is permissible only during the period of transition to spawning temperatures.

For fish stocked into tanks of one of the three LLTUHB units with common water supply and cooling systems, the best performance has been recorded at variable temperature regime, i.e. the temperature is lowered after stocking of each lot of fish and is increased before the next stocking. The use of species-dependent optimal temperature regimes of accumulation provides high survival rates and hatchery success when using various seasonal forms of breeders.

Statistical analysis of multiyear hatchery trial data and the physiological state of breeders has enabled the identification of optimal holding regimes for each sturgeon species and seasonal race. These regimes also depend on the conditions for obtaining mature gametes. In the case of long-term holding (2–6 months from April to September) of vernal Russian sturgeon in the prespawning state, the automated system sets the temperature to 4–5 °C, while at short-term holding (< 2 months) the temperature is set to 6–7 °C. The negative gradient at transition to CRH is 2–3 °C per d.

Only early hiemal and vernal forms of stellate sturgeon should be exposed to long-term holding (> 2 months). The hiemal breeders should be kept for 2–5 months at a temperature of 6–8 °C. For stellate sturgeon captured in autumn and overwintering at a natural temperature regime in an LLTUHB or in wintering ponds, it is recommended to use lower temperatures (4–5 °C). In the case of long-term holding, this is essential (Chebanov and Savelyeva, 1995). The daily temperature variation should not exceed 1 °C (optimum), but a brief 2 °C increase will not affect the reproductive quality of breeders.

In the course of long-term preservation of potential productivity of breeders at low temperatures and during the period of transition to spawning temperature regime (STR), the products of metabolism are eliminated with the full water exchange. The rate of water exchange depends on the temperature and aeration intensity (or oxygenation). The freshwater supply rate determines the water quality and should be arranged accordingly (Table 40).

**Table 40:** Relation between freshwater demand and water temperature in tanks.

Water temperature, °C	Water demand, liter/s	
	Minimum	Maximum
4–6	0.2	0.3
7–9	0.4	0.5
10–15	0.6	0.8
16–21	1.0	1.2

When using a zeolite filter, freshwater discharge can be reduced by more than 85 percent or avoided.

### **8.3 TRANSITION OF BREEDERS TO SPAWNING TEMPERATURE REGIME (STR)**

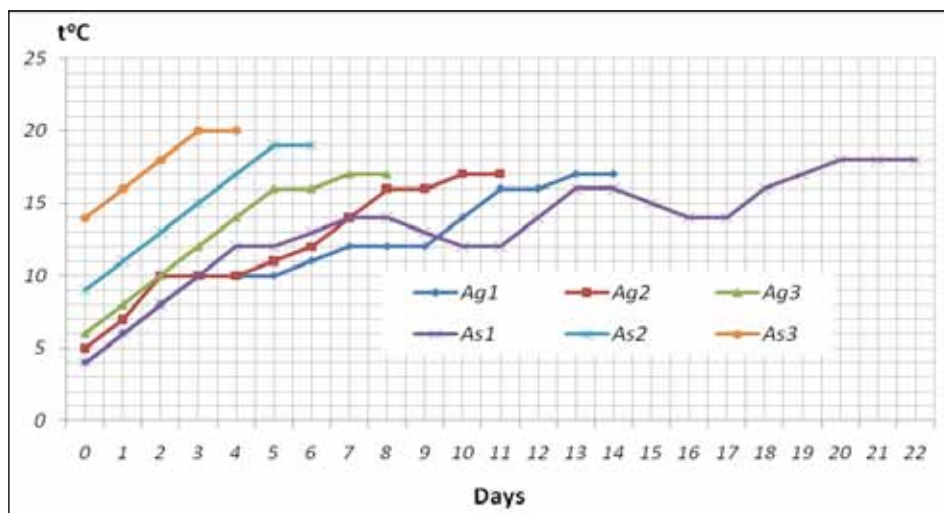
A technique of withdrawal from the reserved prespawning state at STR for different sturgeon species depends on the duration of fish holding at low temperatures (Chebanov and Savelyeva, 1996). Trials have demonstrated that transition of sturgeons to the final stage of the reproductive cycle after long-term holding at low temperatures cannot be routinely performed by simple linear temperature increase within a specified preplanned daily gradient (Kazansky and Molodtsov, 1974).

#### **8.3.1 Russian sturgeon**

The following three regimes of transition to STR have been developed:

1. During first 3 d, the temperature is increased with 2 °C per d gradient. Then the desired temperature of 10–11 °C should be maintained during 2–3 d. The next day, it should reach 12 °C and be maintained at this level for a further 3 d; only then can the desired spawning temperature be reached by linear increase with gradient of 2 °C per d. Then, the total balance of spawning temperatures should be considered and further injection may be administered (Table 41). A simulation model based on spawning temperature balance and time intervals (start of egg extraction) was developed to assist calculations related to transition of breeders to the STR (Chebanov, 1996b). At long-term holding of sturgeon with initial gonad maturity stage IV, hormonal injection is administered 2–3 d after reaching the target spawning temperature.
2. The transition of sturgeon breeders to spawning temperatures after 2-months holding at 4–5 °C is slightly different. During the first day, the temperature should be increased to 7 °C and then to 10 °C. The temperature should be maintained within the acceptable range (10–11 °C) for 3 d and then increased via a 2 °C gradient until the target spawning temperature (14–18 °C) is reached.
3. At holding of sturgeon within a temperature range of 6–7 °C, maturation can be achieved by increasing the temperature using a 2–3 °C per d gradient, considering the fact that holding at this regime slightly slows the process of oogenesis. In this case, the target temperature is reached without intermediate phases (Figure 104).

**Figure 104:** Protocol of temperature change to induce spawning state in wild sturgeon broodstock after long-term holding at low temperatures. **Key:** Ag1 – *Acipenser gueldenstaedtii* 2–6 mon at  $t < 5$  °C; Ag2 – *A. gueldenstaedtii* 2 mon at  $t < 5$  °C; Ag3 – *A. gueldenstaedtii* 1 mon at  $t < 6-7$  °C; As1 – *A. stellatus* 2–5 mon at  $t = 6-8$  °C; As2 – *A. stellatus* 1.5 mon at  $t = 9-12$  °C; As3 – *A. stellatus* 1 mon at  $t = 12-16$  °C.



### 8.3.2 Stellate sturgeon

For stellate sturgeon, like Russian sturgeon, transition of breeders to the spawning state after long-term holding at low temperatures requires a variable temperature regime with alteration of activation/inhibition of the ripening process until hormonal injection. It has been established that transition of stellate sturgeon to STR requires more time than transition of Russian sturgeon.

At 50–70 d holding of early hiemal or vernal stellate sturgeon, the duration of transition to the spawning state should be not less than 20 d, with gradual increase to the lower limit of spawning temperature (12 °C). Further temperature increase should alternate with its decrease within the spawning temperature range. The sum of cumulative spawning temperature for stellate sturgeon after long-term holding at low temperatures leading to definitive functional maturity ranges between 250 and 300 degree-days (Chebanov *et al.* 1991, Chebanov and Savelyeva, 1999). This seems to be very important, as fish kept at low temperatures respond poorly to hormonal injection if accumulation of thermal energy is insufficient, which leads to poor offspring viability (Table 41). The lowest number of females capable of producing viable progeny is observed when the spawning temperatures effect is minimal.



**Table 41:** Influence of holding duration at spawning temperatures (after long-term holding at low temperatures) on hatchery indices of female stellate sturgeon.

Indices	Duration of the spawning regime, degree d		
	100–150	200	250–350
Ovulation rate after injection of GnRH $\alpha$	80–90	80–90	90–100
Quantity of females with high quality eggs, %	40–60	65–75	80–100
Fertilization rate, %	75–85	85	90
Mortality of embryos during incubation period, %	30–40	30	20
Mortality of larvae, %	30–40	35	15–25

### 8.3.2.1 The peculiarities of prespawn holding of summer-spawning stellate sturgeon

This technology is of major importance for the restoration of natural heterogeneity of the stellate sturgeon population. Proper holding regime selection should be performed on the basis of the application of the biopsy and oocyte polarization index express methods (Kazansky *et al.*, 1978). Such adaptive management of the breeder maturation regime ensures the success of hatchery operations.

Summer-spawning stellate sturgeon that migrate during the second half of May at 16–18 °C show high resistance to long-term holding at 9–12 °C and maintain their reproductive power. Breeders captured in June at 20–22 °C, on the contrary, are sensitive to low temperature – holding at 5–9 °C causes not only loss of the functional maturity state but also leads to physiological disturbances in the organism. Thus “June” stellate sturgeon should be kept at lower limit of the **spawning** temperatures range (12–16 °C). For summer-spawning stellate sturgeon, the process of final maturation after CRH does not require long-term preparation. The target spawning temperature (19–20 °C) can be reached during 2–4 d. Hatchery productivity of females from this ecological group depends on the initial state of the reproductive system and compliance with temperature regime requirements: the higher initial maturity requires that the temperature be at the lower limit of the spawning range in the terms of the CRH (i.e. 12–13 °C). Hence, at spring-summer holding at temperatures close to the threshold spawning temperatures, the duration of breeder transition to LTR is two times shorter as compared with the duration of transition of those breeders kept at a temperature 5–7 °C lower than the minimum spawning temperature (Chebanov and Savelyeva, 1999; Chebanov, Galich, and Chmyr 2004).

The long-term holding of fish in the LLTUHB requires optimal ambient conditions. Thus any deviation from the standard affects the fish more strongly than it would in natural conditions. Thus it is recommended to use an automatic system to control the thermal regime in LLTUHB. Hence, specific regimes for

long-term holding at low temperatures and transition of breeders to the spawning state should be based on intrapopulation structure studies and regional ecological peculiarities, which are sturgeon-species specific.

## **8.4 REGIME OF EGG INCUBATION AND THERMAL ADAPTATION OF PRELARVAE**

### **8.4.1 Egg incubation**

The thermal regime of incubation of eggs obtained out of season (e.g. in summer) from sturgeon breeders held at low temperatures in the prespawning state primarily determines the efficiency of the biotechnology process. The seasonal temperature in sturgeon facilities during this period is considerably higher than that in the incubation systems of LLTUHB. The differential temperature is as low as 10 °C. A sharp temperature increase during the incubation results in atypical embryo development leading to malformations such as asymmetry in axial organs with regards to the yolk sac, curvatures, underdevelopment of preanal and caudal sections, etc. The process of hatching tends to be considerably prolonged (Dettlaff, Ginsburg and Schmalhausen, 1993).

Therefore, the thermal regime of egg incubation should be adjusted for timing of hatch and various stages of embryogenesis. Three thermal-related approaches of egg incubation at LLTUHB have been elaborated:

1. The start of stellate and Russian sturgeon breeder incubation is performed through a gradual increase of temperature with a daily gradient of 1–1.5 °C up to the ambient temperature. The lower the water temperature, the longer the incubation period. At the start of prelarval hatching, the temperature increase may be sped up to 2–3 °C during 4 h.
2. The second approach involves egg incubation until stage 28 (direct, straight cardiac tube) performed at low temperatures (for Russian sturgeon, 11–13 °C; for stellate sturgeon, 15 °C). Further temperature increase is performed with 2 °C per d gradient.
3. The third approach involves imitation of daily water temperature fluctuation by decrease and increase of temperature within the 2 °C/d range. During this process, the mean temperature should be maintained over the next two days. This enables the control of the incubation process, slowing down egg development by a 3–5 °C temperature decrease in the incubation system. Maximum allowable duration of water temperature decrease is 4–6 h.

### **8.4.2 Temperature adaptation of prelarvae**

It is common practice to perform hatching of embryos in LLTUHB at temperatures that are considerably lower than in nature. Therefore, prelarval transition to outdoor tanks or ponds requires their thermal adaptation to environmental conditions. In this case, hatched prelarvae should be transferred from the collecting tanks to the

tanks or trays of LLTUHB (stocking density can be elevated to 20 000–25 000/m<sup>2</sup>) connected to the recirculation system. The regime of 1–1.5 d temperature adjustment to outdoor values (in tank units or ponds) is set via an automated system.

The viability of sturgeon progeny obtained in nontraditional seasons at artificial rearing was evaluated on the basis of numerous trials. The necessity of such assessment was due to the fact that the process of egg incubation is conducted at lower temperatures than the successive grow out and rearing of fry. Adaptation to high environmental temperature takes place during the last stages of embryonic development and the first days posthatching. According to the results (Galich, 2000a; Chebanov, Galich and Chmyr, 2004), fry obtained from stellate sturgeon of the later part of the run differ in their morphological and physiological characteristics from those produced from fish from the first part of the run.

In summary, out-of-season sturgeon fry obtained by long-term holding of breeders at low temperature in the prespawning state and the adaptation of their progeny to ambient temperature conditions has proven successful and allows the scale of sturgeon hatchery stock enhancement to be increased (Chebanov *et al.*, 2002; Galich and Chebanov, 2004).

## Chapter 9

### Ecological-morphological and ethological- physiological express estimation of viability of sturgeon larvae, fry and fingerlings

#### 9.1 POLYFUNCTIONAL EVALUATION OF LARVAL AND FINGERLING FITNESS INDICES

Monitoring of larval and fingerling quality is a key component of the artificial reproduction of sturgeon (i.e. hatchery stock enhancement, rehabilitation programmes) and should be performed not only prior to release of fingerlings into the wild but also throughout the entire technological cycle. In the course of the monitoring, all selected parameters should be controlled to ensure their compliance with normative (standard) values.

Polyfunctional evaluation is also necessary for selection of fry intended for farmed broodstock, release and commercial rearing. In the latter case, fingerlings should have high growth rate and low FCR and do not require strict selection on the basis of fitness indices. The effects of hatchery broodstock and progeny domestication, through which fish are adapted to hatchery conditions by artificial selection, can negatively affect the survival of fingerlings and the status of populations under natural conditions. Additionally, domestication may also decrease “fitness indices” via lowered resistance to diseases and extreme environmental influences (Lukyanenko, Kasimov and Kokoza, 1984), malformations of the reproductive system, etc.

*In vivo* methods for quality assessment and monitoring of progeny development should satisfy several general requirements (Nikonorov and Vitvitskaya, 1993). These methods should:

- include integral indices which characterize the functional state of hatchery-reared larvae and fingerlings;
- reduce the duration of hatchery trials and the risks associated with prelarval, larval and fingerling injuries and mortality;
- ensure the possibility of evaluating the feasibility of further improvement of survival and normal development, as well as factors affecting survival and the genetic structure of the population; and
- include the suite of characteristics closely associated with general factors that determine the survival of fingerlings after their release into the receiving habitat.

#### 9.2 *IN VIVO* ASSESSMENT METHODS: EXPRESS TESTS

The following express tests to evaluate the quality of the sturgeon progeny obtained in hatcheries meet the above prerequisites (Galich and Chebanov, 2004, 2009).

### 9.2.1 Species-specific prelarval behavioural response to change the depth differential

Evaluation of prelarval quality is performed with the use of the species-specific behavioural response to changes in the depth. Only viable larvae are capable of making the “swim up and drift down” movement (Khodorevskaya, Ruban and Pavlov, 2009). This behavioural response is due to natural riverine conditions and is associated with different substrates (gravel or silt and sand). As distinct from pebble substrate, a silt and sand bottom is less appropriate for prelarvae (e.g. lower oxygen regime, higher probability of silting, occurrence of small predators). Viable prelarvae exposed to unfavourable riverine conditions tend to display a more intensive up and down movement that leads to their drifting to more friendly reaches of the river. Hatched prelarvae with various morphological abnormalities of the head, heart, yolk sac, etc. are not capable of performing these periodic vertical movements and under natural riverine conditions may relocate to deeper sections and die due to siltation. The quality of the progeny can be evaluated by considering the intensity of upright movement (Table 42). The intensity of the “swim up and drift down” behaviour produced by the prelarvae of beluga and Russian sturgeons tends to increase throughout the period following hatching (Khodorevskaya, Ruban and Pavlov, 2009). As stellate sturgeon prelarvae held at higher temperature transit to branchial respiration during the first 24 h post-hatch, the maximal intensity of upwards movement takes place during this period.

**Table 42:** Maximal intensity of “swim-up and drift-down movement” of prelarvae at various depths (Khodorevskaya, Ruban and Pavlov, 2009).

Species	Age, d	Depth, cm	
		20	100
Russian sturgeon	3	1.6	0.7
Stellate sturgeon	1	2.1	1.7
Beluga sturgeon	5	4.1	1.1

After the transition to passive branchial respiration, a drop in “swim up and drift down” frequency is observed, and prelarvae start to perform horizontal movements. This frequency becomes insignificant at the onset of mixed feeding. During the first three days, prelarvae of Russian and stellate sturgeons exhibit highest sensitivity towards depth variation. For beluga sturgeon, the response to this parameter is weaker due to a less-developed statoacoustics organ at this stage. Testing is carried out immediately after hatching to estimate the percentage of prelarvae adequately responding to the depth change. This test may also be used to evaluate breeder quality on the basis of the performance of their progeny and during the selection of larvae intended for broodstock development and replenishment.

### 9.2.2 Swimming capacity of sturgeon larvae and fry

The next test which characterizes the viability of sturgeon larvae and fry is a test of “rheoreaction” (Pavlov, 1966) or “rheotaxis” (Lyon, 1905) that is based on the fact that fish typically swim against a current. This test involves the timing of the up-stream movement of fish against a specific velocity (Pavlov and Saburenkov, 1974). The swimming capacity of the sturgeon fry should be determined in trials with the use of a hydrotray with constant depth, similar to the tray of Bams (1976), starting from the stage of prelarval hatch (Khodorevskaya, Ruban and Pavlov, 2009). Prior to larval transition to exogenous feeding, the current velocity in the tray should be maintained at 15.8 cm/s and subsequently increased to 20.6 cm/s at further developmental stages. Note that the general fitness of the body and the position of the fins play important roles in determining swimming capacity and resistance to the current. During the first days post-hatch, sturgeon prelarvae lack fins and have a weakly developed caudal section; thus they are capable of only vertical movements (“swim ups”), by means of wave-like movements of the entire body. Upon transition to exogenous feeding, the larval body attains a typical adult shape, with a large elongated tail and characteristic snout (rostrum) structure suitable for maintenance of swimming capacity and lowered current resistance. An increase in duration of capability to resist the current is observed at the onset of exogenous feeding of larvae.

During the period of transition to exogenous feeding, the larval swimming capacity of beluga (at a current velocity of 15.8 cm/s) is equal to 120, while that of Russian and stellate sturgeons are 180 s and 80 s, respectively. The increase in flow velocity in a hatching tray up to 20 cm/s leads to a decrease in swimming capacity (Table 43).

**Table 43:** Alteration of larval swimming capacity in a water current of 20 cm/s velocity (Khodorevskaya, Ruban and Pavlov, 2009).

Water temperature, °C	Age, d	Length, mm	Weight, mg	Swimming capacity, s*
Russian sturgeon				
19.5–21.6	8–9	18.4–19.7	34.0–39.8	45.0
22.0–22.4	13–18	23.4–25.0	48.0–79.3	64.0
Stellate sturgeon				
22.3–22.4	5–6	16.2–17.0	26.4–26.6	15.0
22.5–22.9	8–15	21.0–23.4	31.0–65.0	48.0
Beluga sturgeon				
19.2–21.1	10–11	21.5–22.0	69.5–72.4	30.8
22.5–22.9	16–20	28.0–34.0	74.0–89.0	95.0

\* s = seconds that the larvae is able to resist the current.

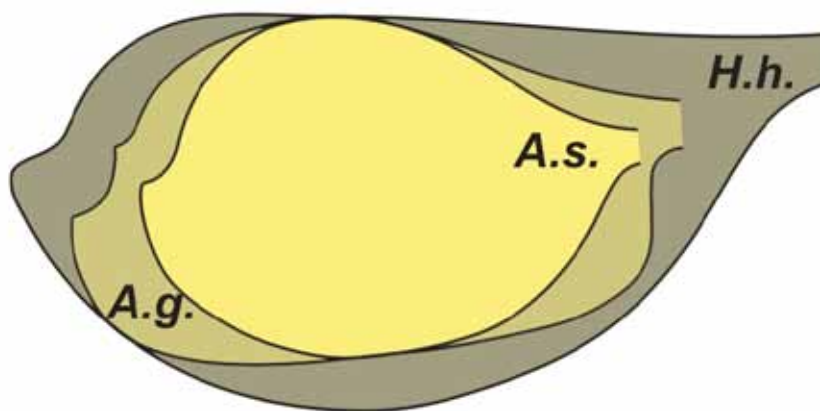
The swimming capacity of older stellate sturgeon larvae is higher than that of Russian or Beluga sturgeon. This is associated with peculiarities of the stellate sturgeon body structure (the maximum thickness of the body is 6.1

percent less than that of beluga sturgeon) and its ability to resist the water flow (Khodorevskaya, Ruban and Pavlov, 2009). Thus a 22 mm stellate sturgeon larva is able to resist the current for 48 s., while 60 mm and 90 mm fingerlings are able to resist for 350 s and more than 3 600 s, respectively. The swimming capacity of both hatchery-produced and “wild” juveniles is length dependent. For example, 45 mm fry of hatchery-bred stellate sturgeon have a mean swimming capacity of 467 s, while the capacity of 77.5 mm and 128 mm fingerlings is 1 499 s and 2 536 s, respectively (at 20 cm/s current velocity). In the case of juveniles (of mean length 62.6 mm) obtained from wild stellate sturgeon breeders, the swimming capacity is 357 s, while at lengths of 68.8, 107.8 and 115 mm, the respective capacities are 367, 651 and 1390 s. The swimming capacity of the juvenile sterlet also depends on its size. At a length of 65 mm, it is equal to 125 s, at the length of 95 mm – 940 s and at 125 mm – 1280 s.

### 9.2.3 Evaluation of the size and shape of yolk sac

The importance of yolk-sac size evaluation in the course of hatchery and environmental monitoring of hatchery-produced prelarvae should be noted (Figure 105).

**Figure 105:** Outlines of the yolk sac in prelarvae of different sturgeon species at stage 36; lateral view (modified from Dettlaff, Ginsburg and Schmalhausen, 1993). **Key:** H. h. – *H. huso*; A.g. – *A. gueldenstaedtii*; A.s. – *A. stellatus*.



The height to length ratio of the yolk sac (normal range: 0.55–0.69) is an important indicator of larval deformations. For malformed (pear-like or oval) yolk sacs, this range is decreased to 0.29–0.44 (Belyaeva, 1983). In fact, at low sac size (and considerable variability in individual morphometric characters), endogenous reserves are not sufficient to provide further growth and normal development at one of the most critical phases, namely transition to external feeding. However, large yolk-sac size at stages when differentiation of the sections of the alimentary system is occurring, is also detrimental to development, causing a delay in the secretory functioning of the epithelium (Gerbilsky, 1957; Bogdanova, 1972).

### **9.3 ANAPHASE METHOD FOR COUNTING CHROMOSOMAL ABERRATIONS IN LARVAE**

This method enables the direct determination of the frequency of chromosomal abnormalities in fish oocyte cells, which can be caused both by mutagens and by variations in holding conditions. Counting of chromosomal aberrations provides a suitable parameter for monitoring female physiological status, egg quality, artificial spawning conditions and optimal holding conditions of sturgeons (Svardson, 1945; Serebryakova, 1985).

At identification of chromosome abnormalities, single and group chromosome and chromatid bridges, paired and single fragments, chromosome delay and multipolar mitosis are taken into account. Aberrant mitoses are considered as single abnormalities, despite the number of aberrations per mitosis. After the assessment of the quantity of normal and aberrant anaphase- telophases, the percentage of aberrant cells is calculated using the formula:

$$A/B*100\%$$

where: **A** = number of abnormal cells; and **B** = total number of cells.

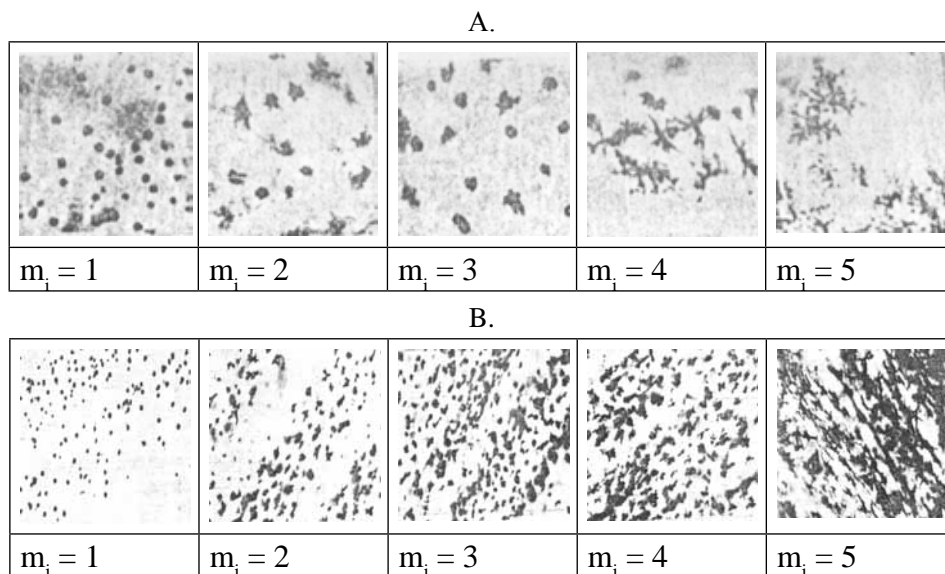
In past years, the background natural level of mutation in Russian sturgeon prelarvae at the Sea of Azov basin hatcheries was 1.45–5.3 (Kuzina, 2005).

### **9.4 THE MELANOPHORES (PIGMENT CELLS) BACKGROUND RESPONSE**

An assessment of the physiological state of larvae can be based on the melanophores (pigment cells) background response, which reflects the state of the neuro-hormonal system that determines the ability of larvae and fingerlings to exhibit protective colouration and thus to survive in the wild (Krasnodembskaya, 1994). A five-level scale of melanophore indices (mi) has been developed to assess the level of pigment aggregation and dispersion in melanophores. The maximum mi value of 5 indicates maximum pigment dispersion and darkening of body colouration, while the minimum value of 1 indicates maximal pigment aggregation and lighter colouration (Figure 106).

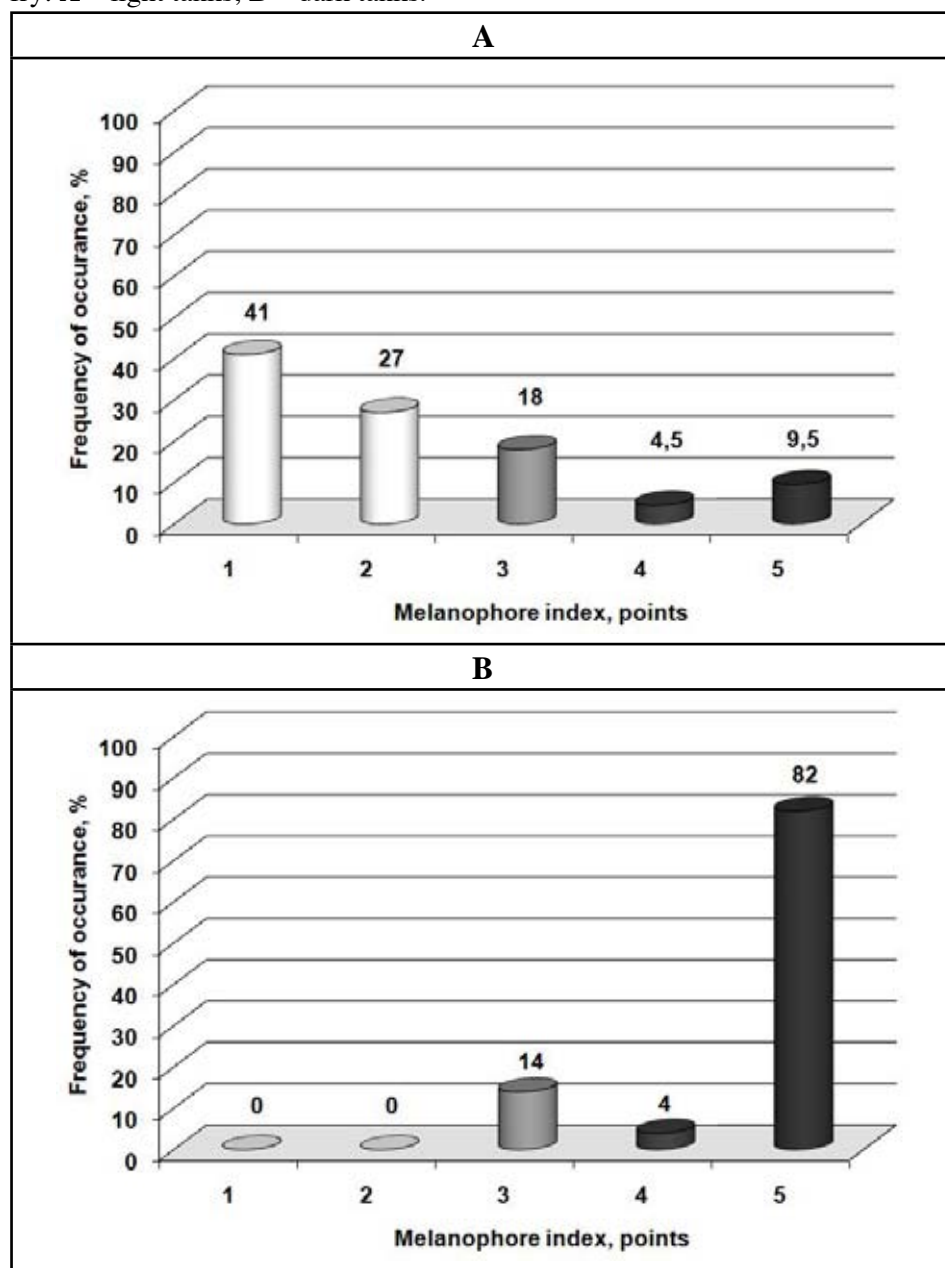


**Figure 106:** The five-grade scale for assessment of the functional status of melanophores according to melanophore index value ( $m_i$ ) in sturgeon (Krasnodembskaya, 1994): **A** – at larval stage (melanophores of the head and lateral body surface); **B** – in sturgeon fry (melanophores of the pectoral fins).



The state of the melanophores of the rostrum and lateral body surface should be assessed for sturgeon larvae, while that of the pectoral fin melanophores is assessed for fry. It has been established (Galich, 2000a; Galich and Chebanov, 2004) that inadequate adaptive response of melanophores is typical only for underdeveloped larvae and fry (Figure 107).

**Figure 107:** Experimental assessment of pigmental reactions in Russian sturgeon fry: **A** – light tanks; **B** – dark tanks.



The timely adaptive response of melanophores to dark/light background is associated with the functional norm of elements of the neurohormonal system in sturgeon. As distinct from the traditional protocol involving lethal ethanol fixation of larvae, the use of a digital camera is recommended to ensure fry survival and facilitate computerized data processing. By using this method, a quantitative estimate of the degree of pigment aggregation or dispersion is available.

## 9.5 TERATOLOGICAL ANALYSIS OF LARVAE AND FINGERLINGS

Teratological analysis of larvae and fingerlings of different species enables evaluation of the frequency of morphological abnormalities in hatchery-reared progeny (Table 44) obtained from wild and domestic breeders (Galich, 2000a; Chebanov, Galich and Chmyr, 2004).

**Table 44:** Abnormalities in sturgeon gametogenesis and early ontogeny (Akimova *et al.*, 2004).

Type of abnormality	Manifestation
Abnormalities in the body shape	Abnormalities in head shape, curvature of body and tail; underdevelopment of pectoral fins; structural abnormalities in the fin fold; anomalous shape of yolk sac, etc.
Structural abnormalities in the external organs	Hypertrophy of the hatching gland; absence of one or both eyes; hypertrophy (or small size) of an eye; cataract; underdevelopment of gill covers; underdevelopment of barbels; anomalous olfactory organs (schistasis of the nasal bridge, underdevelopment of the olfactory pits, etc.); thinning and ruptures of the abdominal wall, etc.
Structural abnormalities of the internal organs	Absence of the fourth ventricle of the medulla oblongata (or small size of the ventricle); anomalous heart structure (underdeveloped heart tube (narrow, curveless or with left side bent); abnormalities in development of the digestive system (presence of the protoseptum between the larynx and esophagus, underdevelopment of the liver or pyloric caeca, defects in intermediate or spiral intestine, etc.)
Abnormalities in the tissue structure	Separation, thinning and rupture of the tectorial epithelium; epithelial strumae on the body, tail; tumor-like proliferation on the body and tail, fins, yolk sac tissue; skin pigmentation disorder; cavities in the striated muscle.
Functional abnormalities	Haematomas in various organs and tissues; abnormalities in water-salt metabolism: <ul style="list-style-type: none"> <li>• hydrocephaly of the fourth ventricle of the medulla oblongata;</li> <li>• pericardial edema;</li> <li>• edema around yolk sac, fin fold and abdomen;</li> </ul> abnormalities in lipid metabolism: presence of large oil drops in the mouth, pericardium, abdominal cavity, intermediate and spiral intestines, etc.).
Mechanical abnormalities	Body and tail damage; ruptured integument; lack of tail parts or fins due to mechanical effects and cannibalism.

As a more detailed description of the morphological abnormalities occurring in sturgeons during early ontogenesis is beyond the scope of this document, readers should refer to specialized publications such as Akimova *et al.* (2004). Most of the malformations listed above affect fry survival (Goryunova, Shagaeva and Nikol'skaya, 2000). However, a few abnormalities do not influence larval or fry viability (e.g. schistasis of the nasal bridge, absence of one or both eyes, slight defects in muscle tissue structure, underdevelopment of fins), but can be observed instead in adult fish.

## 9.6 KPHYSIOLOGICAL AND BIOCHEMICAL EVALUATION OF THE STATE OF STANDARD HATCHERY-PRODUCED STURGEON JUVENILES

On the basis of experience in the hatchery quality control of “standard” sturgeon juveniles (in compliance with Russian state sturgeon hatchery standard of age and weight) reared at some sturgeon hatcheries of the Sea of Azov basin, it has been suggested to apply a set of physiological indices (Table 45) determined by conventional biochemical and haematologic techniques.

**Table 45:** Summary of physiological state characters in viable “standard” hatchery-produced sturgeon juveniles (Badenko *et al.*, 1984).

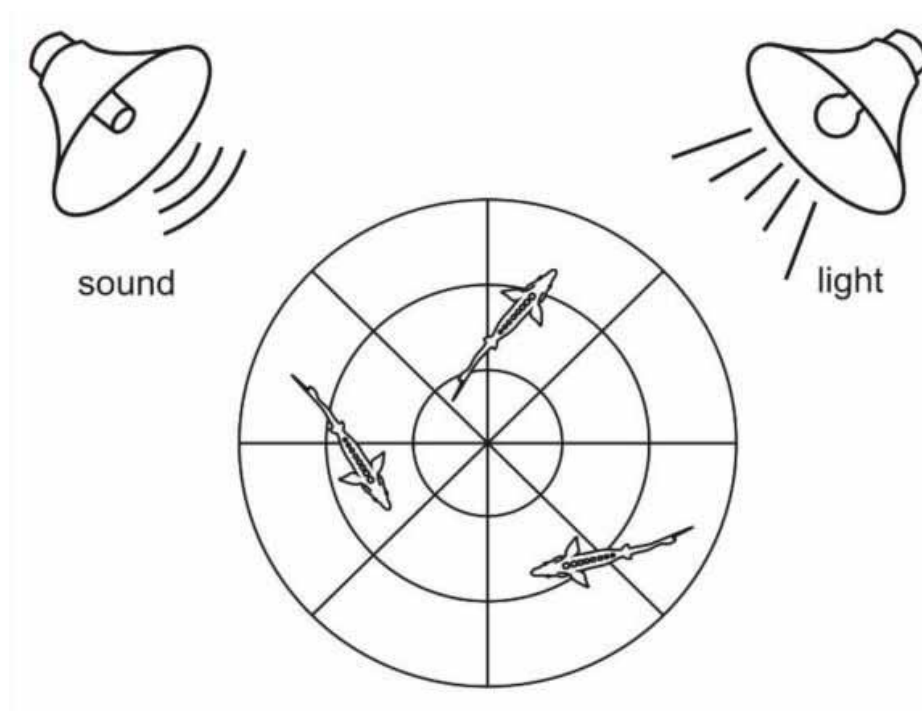
Character	Russian sturgeon	Beluga sturgeon	Stellate sturgeon
Age, d	40–50	40–50	40–50
Length, cm	7–10	7–11	7.5–11
Weight, g	2.2–3.9	1.6–5.2	1.5–2.5
Haemoglobin, g%	4–5	3–4.5	4–5.2
Erythropoiesis, %	20–50	40–45	35–40
Protein concentration:			
in blood serum, g%	1.8–2.7	0.7–2.0	0.7–1.8
in muscles, mg/g	75–150	85–125	140–180
Concentration in muscles, %:			
Water	77–88	85–87	80–86
Fat	4–7.5	3–6.5	4–7.5
Leukogram, %:			
lymphocytes	72–77	40–50	58–65
monocytes	0.1–1	1–1.5	0–1
polymorphonuclears	14–25	29–43	30–32
eosinophiles	2–9	10–30	5–9
number of white blood cells in field of view	1–1.5	1–1.5	1–3

Unfortunately, the common physiological and biochemical indices presented in the table cannot be recommended for wider application in a juvenile monitoring programme intended for optimization of hatchery management, despite their informative value. This restriction is associated with the fact that the techniques used for biochemical and haematological analyses are not rapid and do not meet the requirements of *in vivo* polyfunctional assessment of sturgeon juvenile fitness indices, i.e. avoidance of traumatism and mortality.

## 9.7 EVALUATION OF ADAPTIVE QUALITIES OF JUVENILES ON THE BASIS OF CENTRAL NERVOUS SYSTEM RESPONSE

The “open space” test (Figure 108), designed to assess the response of the central nervous system (CNS) in juveniles to rapid environmental changes, allows evaluation of the fish’s ability to adjust its locomotory activity to strong sensory stimuli (visual, tactile, hydrodynamic) and survive in the wild (Tikhomirov and Khabumugisha, 1997). The trials involve the estimation of experimental juvenile behavioural response to different external stressors (light and sound of various frequencies). The fingerlings should be placed in a round aquarium (1 m diameter), with its bottom divided into eight sectors. The number of bottom lines crossed by a fish during a certain period is to be recorded. The experimental chronological scheme is presented in Table 46.

**Figure 108:** The “open space” test.



**Table 46:** Chronological scheme of the “open space” test.

<b>Time, min</b>	<b>Stressors</b>
1–3	Adaptation of the fish to new conditions (experimental containers)
3–5	Post-adaptation period
<b>Low-frequency noise</b>	
5–7	Observation of noise response
<b>High frequency noise</b>	
7–9	Observation of noise response
	Constant light
9–11	Observation of illumination response
<b>Short-term light</b>	
11–13	Observation of illumination response

Adaptation of fish to new conditions takes about 3 min. During this interval, the approximate locomotory activity (AA, unit/min) should be determined by calculating the mean number of lines crossed by the fish. When the locomotory activity becomes more or less constant, the mean number of bottom crossings is considered as a background activity (BA, unit/min). After exposure to the stressor, the reactivity (RA, unit/min), the average number of crossings during the next 30 s, should be determined. During this assessment, the juveniles can show both negative and positive response to external stressors. The relative activation indices are determined on the basis of the absolute indices (AA and RA) in order to evaluate the degree of sturgeon juveniles locomotory activity resulting from the strong stimuli:

$$IA\% = AA/BA*100\%;$$

$$IR\% = RA/BA*100\%$$

where, **IA%** = activation index; **AA** (unit/min) = approximate locomotory activity; **BA** (unit/min) = background locomotory activity; **IR** = reactivity index; and **RA** (unit/min) = reactivity.

Data for the comparative analysis of the locomotory activity of stellate sturgeon juveniles (domestic form and those obtained from wild breeders collected in the Sea of Azov) (Chebanov, Galich and Merkulov, 2008) in the test of “open space” are given in Table 47 as an example.

**Table 47:** Indices of locomotory activity of stellate sturgeon juveniles obtained from wild and farmed broodstock. **Key:** **AA** – approximate locomotory activity; **BA** – background activity; **IA**– activation index; **IR1** – reactivity index during the first 30 s after exposure to low-frequency noise; **IR2** – reactivity index during the first 30 s after exposure to high-frequency noise; **IR3** – reactivity index during the first 30 s after the exposure to constant light; **IR4** – reactivity index during the first 30 s after exposure to light flashes.

Group	AA	BA	IA	IR1	IR2	IR3	IR4
Wild	34.5	13.2	261.3	110.2	132.9	99.5	89.7
Domestic (farmed)	39.7	19.7	201.5	88.9	71.3	57.5	42.9

Evaluation of the ability of hatchery-produced sturgeon juveniles to survive in natural waterbodies by using the “open space” test and determination of swimming capacity via juvenile sorting in hydrodynamical trays with regulated current velocity under the conditions occurring in sturgeon hatcheries may be more effectively carried out in the special system “Ikhthyotest” (Tikhomirov and Khabumugisha, 1997; Nikonorov and Vitvitskaya, 1993).

## 9.8 NEURO-PHARMACOLOGICAL TESTING OF JUVENILES

Neuro-pharmacological testing of juveniles based on the evaluation of their tolerance to abiotic stressors is also a nonlethal operative method (of less than 30 min) for fish viability assessment (Nikonorov and Vitvitskaya, 1993). The considerable advantage of this method is its simplicity of application, enabling large-scale use of the neuropharmacological evaluation at release into natural waterbodies and selection of fish intended for replacement broodstock. The juveniles exhibit more consistent tolerance of neurotropic preparations, a high viability level and resistance to critical limits of temperature, salinity, oxygen deficiency and sensory stimuli, and have a more consistent level of metabolism. The method is based on the timing of anesthetic effect causing stable fish narcotization, expressed in lost balance and cessation of tail movement.

Observation of the effects of anesthesia on the behaviour of fry allows three major stages to be distinguished:

- the increase in physical activity with the further disorder in coordination of movements;
- the suppression of the background activity of fish and the loss of the equilibrium reflex; and
- the cessation of external respiration and motion.

The restoration of the vital activity of anaesthetized fish when they are placed into clean water proceeds in the opposite sequence. It should be noted that there exist species-specific weight-related variations in sturgeon fingerling response to the administration of neuropharmacological preparations (drugs) (Table 48) (Galich, 2000b).

**Table 48:** The dynamics of motionlessness and restoration of physical activity in sturgeon fry (% of total number) anaesthetized by MS-222 at 50 mg/liter.

Species	Time of sedation (knock out), Min						Time of recovery in clean water, min					
	5	10	15	20	25	30	1	2	3	4	5	6
Stellate sturgeon (large)	10	60	80	80	–	–	40	60	70	100	–	–
Stellate sturgeon (small)	20	20	20	80	80	80	40	50	100	–	–	–
Persian sturgeon	–	30	30	60	70	70	30	40	40	40	80	80
Russian sturgeon	–	30	40	40	70	70	30	40	40	50	80	100

The following neuro-pharmacological preparations may also be used for the express selection: hinaldin (2-methyl hinolin), clove oil and hinaldin hydrochloride (Nikonorov and Vitvitskaya, 1993).

Neuro-pharmacological testing based on the response of juveniles to neurotropic substances may be performed at different concentrations (50 and 75 mg/liter) of the anaesthetic MS-222 (tricaine methanesulphonate). The time of exposure depends on the concentration of MS-222. Locomotory behaviour, number of sedative-treated fish and rate of their recovery in clean water are monitored throughout the procedure (Galich, 2000b; Galich and Chebanov, 2009).

The tolerance of different sturgeon juveniles to abiotic stressors (e.g. high water temperature (32°C), salinity (12 ‰), oxygen deficiency) evaluated by the so-called method of functional testing (Lukyanenko, Kasimov and Kokoza, 1984) is positively correlated with the sensitivity of juveniles to sedatives. Thus the recovery time can be used as an indicator useful for the overall evaluation of fish viability. This technique is nonlethal as distinct from the lethal method of functional testing.

## **9.9 FLUCTUATING ASYMMETRY AS A STATISTICAL INDICATOR OF JUVENILE VARIABILITY AND FOR ENVIRONMENTAL STRESS EVALUATION**

Fluctuating asymmetry (FA) (random deviations from perfect bilateral symmetry) has become a popular measure of development instability that reflects the inability of an organism to produce regular a phenotype due to genetic and environmental perturbation during ontogeny (Palmer and Strobeck, 2003; Lemberget and McCormick, 2009).

Evaluation of sturgeon fingerling development stability on the basis of FA



indices is one of the key elements of monitoring programmes for sturgeon hatcheries. The evaluation of this parameter is an effective and nonlethal method for assessing intraspecific variability and possible decrease in heterozygosity of developed populations, as well as the occurrence of environmental stressors (Valentine, Soule and Samollow, 1973; Whitlock, 1998; Leung, Forbes and Houle, 2000; Lajus, Graham and Kozhara, 2003). Due to the stochastic nature of this phenomenon, its analysis is possible only at the individual level – level of groups of individuals.

FA is often used as a measure of individual quality as well as fitness (Clarke, 1995), but the relationship between FA and other indices of fitness of fish seems more complicated (Lens *et al.*, 2002).

The estimation of FA in sturgeons may be performed using such bilateral meristic characters as the number of lateral scutes on the right/left, the number of rakers on first gill arch, the number of pectoral fin rays on the right/left, and number of ventral fin rays on the right and left.

The fluctuating asymmetry ( $M_d$ ) can be determined using the following formula:

$$M_d = \frac{\sum d_{l-r}}{n}$$

Where,  $\mathbf{d}$  is the differences between character values at the left and right sides of the specimen body and  $\mathbf{n}$  is the sample size.

Dispersion of FA ( $O^2$ ), which can be used as an index of FA, is determined as:

$$\sigma^2 = \frac{\sum (d_{l-r} - M_d)^2}{n - 1}$$

Differences in certainty of FA dispersion is determined on the basis of the value of the F- criterion of Fischer, while mean values of indices are determined on the basis of Student's t-st- criterion (Plokhinsky, 1970).

Use of only one index in FA-related investigations does not lead to reliable results, thus it is desirable to apply several indices. In this case, each additional index adds one degree of freedom to evaluation of the level of developmental instability (Palmer and Strobeck, 2003).

To perform FA based on the analysis of a few indices, especially for different-sized characters, it is necessary to provide valuation. Generally, normalization is conducted in the following way (Zakharov and Clarke, 1993):

$$FA_{ij} = \frac{|L_{ij} - R_{ij}|}{(L_{ij} + R_{ij})}$$

Another valuation method was suggested in Leung, Forbes and Houle (2000):

$$FA_{ij} = \frac{|L_{ij} - R_{ij}|}{\text{avg}|L_{ij} - R_{ij}|}$$

Where  $\text{avg}|L_{ij} - R_{ij}|$  is the average over all samples in the study. As a result of such valuation, values of asymmetry get distributed over 1.

The obtained evaluations of dispersion FA O<sup>2</sup> for each batch of hatchery-produced juveniles of different species should be used for comparison with O<sup>2</sup> obtained from samples of wild specimens, in some cases, obtained during previous studies. For example, similar evaluation of FA O<sup>2</sup> is given in Dechta (1996) and Dechta and Tsvetnenko (1996).

The FA index for hatchery-produced juveniles of different species is frequently higher (Romanov, 2001 Eriksen *et al.*, 2008; Lajus *et al.*, 2009) than for wild fish samples. Typically, high stocking densities, low water quality and genetic changes caused by directional selection have been identified as the main reasons leading to increased level of FA of hatchery-produced fingerlings. Adaptation to hatchery conditions, even when other factors such as water quality, stocking density, heterozygosity and temperature are under control, can lead to asymmetry increase (Vøllestad and Hindar, 1997). Natural selection against asymmetric individuals in the wild and, as a result, decrease in the level of FA in the wild, is also considered an important factor (Kazakov and Titov, 1998).



## Chapter 10

### Release of fingerlings into natural waterbodies

#### 10.1 INTRODUCTION

The long spawning period, the occurrence of seasonal races (ecotypes) of spawning migrants and the prolonged run of fingerlings into the sea are key environmental peculiarities of sturgeon species. Under natural riverine conditions (unregulated river flow), fingerlings of various age and weight and of different seasonal races (e.g. hiemal, vernal, summer spawning) run to premouth river sites and the sea during different periods. These seasonal variations enable lower feeding competition and optimal feed potential utilization.

Studies of the seasonal dynamics of feed organisms in the river, estuary and mouth area, as well as observations on the survival and growth of sturgeon fingerlings have allowed a new strategy of sturgeon release. This novel approach entails optimization of the process on the basis of species-specific environmental factors, monitoring of seasonal reproduction and the release of different size, age and graded fingerlings in relation to the period of release and annual variation in water flow (high and low) (Chebanov, 1996c; Chebanov and Savelyeva, 1999; Chebanov *et al.*, 2002). Thus prolonged release of various size- and age-graded fingerlings will ensure not only higher survival of released fingerlings, but also the biodiversity of managed populations and the rational use of food organisms in the rivers, estuaries and coastal areas (Chebanov, 1998; Chebanov and Billard, 2001). The release of hatchery production is carried out following the confirmation of its ichthyopathological status (FAO, 2007).

#### 10.2 METHODS FOR ENUMERATION OF RELEASED HATCHERY PRODUCTION

Methods available to enumerate fingerlings released by a hatchery include overall count (by weight, volume and number of individuals) and assessment count. The method chosen should be based on the specific hatchery.

##### 10.2.1 Overall count

All the fingerlings intended for release are to be enumerated by volume, weight and individual count. The enumeration of fingerlings is performed using measuring capacity (not less than 0.5 liter). Each tenth measure is evaluated in order to calculate the arithmetic mean of fingerlings in the samples, and then the overall number of released fingerlings is calculated on the basis of the mean.

##### 10.2.2 Assessment count

Enumeration is carried out prior to the release of fingerlings. A few “count sectors” are defined in the grow-out pond. Sampling is performed using fishing gear (a beam trawl with a wing span 20–25 m or a small seine for benthic juveniles),

for which a catch efficiency index (catchability) is typically determined. Sample collection is carried out at a single point in time or during several very short periods. The overall number of fingerlings in the pond ( $N$ ) is calculated on the basis of the sample analysis, taking into account the catchability:

$$N = \frac{nS}{ks}$$

where,  $n$  = catch per unit effort (specimens);  $S$  = area of the waterbody ( $m^2$ );  $s$  = haul area ( $m^2$ ); and  $k$  = catch efficiency index (Kushnarenko, 1971).

By default, the catch efficiency index of a fingerling trawl is considered equal to 0.5. In addition, a direct relation exists between fingerling weight and catchability index, which increases considerably upon specimens reaching a weight of 4 g. For larger juveniles (those above 10–12 g), the catchability index is considered equal to 0.8 (Kushnarenko, 1971).

For assessment counts for beluga fingerlings of larger weight (5–7 g), the coefficient of trawl catchability is assumed equal 0.25–0.3. This value is stocking-density dependent and increases up to 0.58 if the density is increased to 1 500 individuals/ $m^2$  (Krupiy, Grigoryeva, and Otpushchenikova, 2005).

### **10.3 RELEASE OF FINGERLINGS FROM PONDS**

Water drainage from ponds is performed using special fish traps, from which the fingerlings are to be transported to cages or directly into live fish transport. It should be noted that the holding of fingerlings in ponds (or in separate, well-aerated parts of ponds) prior to release into natural waterbodies for 1–1.5 d will positively affect their adaptive abilities. In addition, swimming velocity of fingerlings that have been deprived of feeding for 1–2 d is considerably higher than that of well-fed fish. This can stimulate the search for feeding sites and increase the survival rate after release.

### **10.4 SELECTION OF OPTIMAL RELEASE SITES**

Release of fingerlings is carried out in defined locations that have been selected in accordance with the biological requirements of the released sturgeon species (Figure 109). The primary factors for identification of release sites are the consistent availability of sufficient food organisms and the state of the bottom (hard, sand or slightly silted beds) to avoid crowding of juveniles within limited areas.

**Table 49:** Basic phases of sturgeon larvae, fry and fingerlings rearing under the regime of gradually increasing salinity (after transition to exogenous feeding) (Kokoza, 2004).

<b>Beluga</b>			<b>Russian sturgeon</b>			<b>Stellate sturgeon</b>		
Salinity, ‰	Weight, g	Days	Salinity, ‰	Weight, g	Days	Salinity, ‰	Weight, g	Days
1,6-1,8	0,8	10	0,5-0,8	0,08-0,1	5	0,8	0,06-0,08	5
2,0	1,0	13	1,0	0,5-0,7	10	1,0	0,4-0,5	15
3,0	1,9-2,0	20	2,0	1,2	22	1,8-2,0	0,8-1,0	20
5,8	2,9-3,0	25	2,2	1,5	25	2,0	1,2	25
8,5-9,0	4,6-5,0	30	4,0	2,0-2,5	30	3,0	1,5	30
12,2-13,0	6,5	35	5,8-6,0	3,5-3,8	35	4,0	2,0	35
			8,0	5,0	40	6,0	3,0	40
			10,0	6,0	43	9,8-10,0	5,0	45
			12,0	7,0	46	12	6,0	50

**Figure 109:** Release of sturgeon fingerlings into coastal sea area.



Release of juveniles into rivers and adjacent to river mouth/sea areas should be spread out in terms of area and time. It is important to consider the state of shoreline vegetation, size of main feed items, lack of predators and pests. Prior to release of juveniles it is necessary to evaluate adequacy of key hydrochemical parameters (i.e. thermal regime, pH, levels of oxygen and toxic substances) towards species-dependent requirements. Thermal and salinity stratification which reduces speed of space distribution of fish should be absent at the place of release. This can cause diminishing in feeding area, an increase in predators pressure and may negatively affect the physiological state of the fingerlings, resulting in a decrease in survival rate (Levin, 1989).

#### **10.4.1 Salinity tolerance of sturgeon juveniles as a criterion for release optimization**

Water salinity plays an important role in the selection of proper sites for the release of sturgeon fingerlings into natural waterbodies. Hence, analysis of the salinity tolerance of different size- and age-graded groups enables optimization of release sites and periods, as well as the development of species-specific schemes for adaptation of hatchery-produced juveniles to various salinities.

In the wild, migrating sturgeon juveniles encounter sea areas of increasing salinity in the course of their growth. The senior juveniles possess more developed mechanisms of osmotic and ionic homeostasis. It is essential that

embryonic development (e.g. for *A. gueldenstaedtii*, *H. huso* and *A. stellatus*) should take place in freshwater (maximum acceptable level of salinity of 2–3 ‰). The developing eggs of the ship sturgeon are the most sensitive to variations in salinity, with high mortality (up to 30 percent) occurring at water salinity as low as 2 ‰ (Kasimov, 1987). The level of morpho-functional development that determines the level of osmotic regulation in sturgeon fingerlings is primarily size and weight dependent. At large fish size, relationships between the surface area of the body and its weight and volume tend to change, as well as those between blood system size and blood volume, and gill epithelium and number of chloride-secreting cells. Large fingerlings of Russian sturgeon at the age of 45 d (length – 10.2 cm, weight – 3.8 g) are capable of adapting without mortality to water of 12 ‰ salinity, while small fingerlings of this age (length – 5.3 cm, weight – 1.0 g) exhibit partial mortality. For larger fingerlings, a change in blood osmolarity in water of 12 ‰ salinity occurs more rapidly than in smaller fish. This proves that the osmoregulatory function in larger fingerlings is more developed.

It has been revealed that upon reaching 2–4 g weight, stellate and Russian sturgeons are capable of resisting rapid transition to water of 12 ‰ salinity. Preliminary adaptation permits their survival in water of salinity up to 16 ‰ (Krayushkina, 1983). Beluga exhibit lower adaptability and are capable of resisting 12 ‰ salinity only upon reaching 6.0 g weight. The developed osmoregulatory system in fingerling anadromous sturgeons is characterized by the ability to transit swiftly from a hypotonic to a hypertonic type of osmoregulation, resulting in a decrease in blood serum osmolarity in water of various salinity to basal level (Krayushkina, 2006).

In the process of sturgeon adaptation to salt water, activation of the excretory function of the gill's chloride cells, which remove excess univalent ions, occurs. The functional activity of endocrine glands (interreginal and thyroid) also tends to increase in the course of adaptation (Dyubin and Kiseleva, 1983). Optimal regimes for adaptation of larvae, fry and fingerlings to gradual increase in salinity are presented in Table 49.

Water temperature has proved to be an important factor during transition of fingerlings from fresh to seawater. A drop in temperature from the optimal range of 20–23 °C to 3–5 °C leads to a decrease in ionoregulation in sturgeons. The quantity of feeds provided is also an important factor that facilitates the successful adaptation of fingerlings to a high-saline environment. In case of insufficient quantity of feeds, fingerlings exhibit depressed ability to maintain constant ionic balance, leading to a decrease in their adaptive abilities. The above mentioned size-age and species-specific differences in salinity and regimes of salinity adaptation are essential for selecting optimal sites for release of hatchery-produced juveniles into natural waterbodies.



## 10.5 TRANSPORTATION OF FINGERLINGS TO RELEASE SITES

Special means of transportation are used to ensure the safety of fingerlings. Stocking densities depend on the type of transport used (Figure 110), the species to be transported, the size of the fingerlings and the conditions of transportation (i.e. duration, temperature, etc.).

**Figure 110:** Specialized live-fish truck with containers providing optimal conditions for transportation of juveniles.



The schedule of pond water drainage and fingerling transportation should be specified taking into consideration that fingerling release should preferably occur during the hours of darkness. During the process of loading into the transport, the fingerlings should be constantly held in water. Loading of fish during the daily peak of temperature should be avoided. The long-term transportation of fingerlings to release sites (e.g. river mouths and seashores) may be performed by special vessels (Figure 111) equipped with systems to control thermal and oxygen regimes (Figure 112). For example, the 1 700 km transportation of sturgeon fingerlings from the Abalasky Hatchery to the mouth of the Ob River was performed by means of a live-fish vessel in containers at a loading density of 30 kg/m<sup>3</sup> and took nine days (Chepurkina *et al.*, 2008).

**Figure 111:** Transportation of sturgeon fingerlings to release sites using a special live-fish vessel (Chepurkina *et al.*, 2008).



**Figure 112:** System to control temperature and oxygen of transport water (Chepurkina *et al.*, 2008).



In order to reduce intraspecific feeding competition and avoid possible consumption by predators at release from live-fish vessels, the fingerlings should be dispersed (released) in small lots along the bar, at sites with a current velocity lower than the cruising speed of adequately sized fingerlings and not allowing mass and prolonged release at one location.



## Chapter 11

### The formation of domestic replacement and broodstock

#### 11.1 INTRODUCTION

Broodstock formation may be carried out by different methods, both by the use of domestication methods for wild spawners or immature individuals, and by rearing from eggs, young-of-the-year or two-year-olds. The use of older fish for replacement and broodstock development is not recommended, but such fish may be incorporated into already formed stocks at the time of recruitment, taking into consideration the genetic characteristics of these fish.

#### 11.2 GENETIC ASPECTS OF DOMESTIC BROODSTOCK FORMATION

The conservation of representative gene pools for sturgeon species and intraspecific groups (dimensional, temporal and environmental) should be provided in broodstocks intended for stock enhancement (i.e. reproduction). The genotypes of fish to be included in a broodstock should represent the genetic structure of the wild population. A set of genetic markers is necessary for genetic monitoring of the broodstock. At initial formation of the broodstock, three-fold selections (at minimum) of each intraspecific group originating from the wild should be ensured. The effective size of each population group should be not less than 250 different age-graded females and males in order to minimize the genetic drift from breeders to progeny for more than 50 successive generations (FAO, 2008).

To decrease the negative effects of domestication (adaptation to artificial environmental conditions), it is wise to avoid all types of selection by ensuring the minimal stocking density possible at any rearing stage. In the case of broodstock replenishment, it is desirable to use an equal number of males and females (Annex IV) and to obtain an equal quantity of eggs from each female. To decrease the level of inbreeding depression of the artificial population that is inevitable due to domestication of broodstock, it is essential to implement the following measures:

- noptimized selection of mating pairs on the basis of molecular genetics analysis, ensuring preservation of rare genotypes;
- use of different age-graded males and females for reproduction;
- use of females and males captured at different locations and during different periods of the spawning run. The rational crossing of domestic females and wild males should be used, and vice versa only in case of the lack of males; in this situation, it is desirable to use a rotational breeding scheme, including 5–10 percent of wild breeders into the broodstock (Bartley, Gall and Bentley, 1985);
- where the number of females is small, the level of heterogeneity of the progeny may be

- considerably elevated by factorial mating. The eggs obtained from one female are divided into equal batches and inseminated by the milt from two to four males; as well, the milt collected from one male donor is used for insemination of eggs from two to three females (Gjerdere, 2005) (Table 50).

**Table 50:** Factorial mating of sturgeon (x = mating).

Number of males	Number of females				
	1	2	3	4	5
1	x	x			
2	x	x			
3			x	x	x
4			x	x	x
5			x	x	x

Wild breeders should be released to the natural environment after genetic testing and obtaining of gametes, excluding those fish that are rare or unrepresented in the domestic stock genotypes. Crossings aimed at conservation of rare genotypes should be done individually, with successive separate rearing of the offspring.

A method for the selection of individual pairs intended for mating that maximizes heterozygosity in the case of American paddlefish was described by Kaczmarczyk, Luczynski and Kolman (2008). For example, during establishment of broodstock of Azov and Black seas Russian sturgeon, it is necessary to select and cull specimens with baerii-like mitotype (which is common for the Caspian population of Russian sturgeon), thus enabling building of a pure stock of Russian sturgeon. The method of baerii-like haplotype identification is based on mt-DNA analysis (Mugue *et al.*, 2008).

### 11.3 FISH FARMING AND BIOLOGICAL CRITERIA FOR BROODSTOCK ESTABLISHMENT

The optimal age structure and size of the broodstock is determined on the basis of:

- dreproductive species-specific indices of sturgeon specimens used at broodstock establishment and the number of intrapopulational groups;
- the age of sexual maturity and the interspawning intervals; and
- actual productive capacities of the hatchery (at the first stage of broodstock formation).

All the age groups represented in the broodstock should be marked by tags (of the corresponding series) and recorded in the pedigree diary. Selection criteria for fish destined for the broodstock are as follows:

- Within genetically homogeneous groups, preference should be given to specimens with good external appearance, absence of malformations

and gametes of high quality (homogeneous egg pigmentation, regular shape, weight and size corresponding to the mean species characteristics, eggs timely (5–15 min) sticking to the substrate when exposed to water, spermatozoa motility of not less than 200 s, sperm concentration of not less than 1.2-2.5 billion/ml<sup>3</sup>).

- In the group of fry that has reached a weight of 2–5 g, malformed and weak individuals should be culled. It is recommended to conduct selection of fry using the methods of polyfunctional express testing. Further selection should be performed using an equal quantity of specimens of all size groups from each family.

Effective population size of replacement broodstock depends on the number of mating individuals. In order to decrease the number of individuals of equal origin, it is necessary to provide equal intake of males and females to each subsequent generation. For broodstock replenishment by one fish, on average, it is necessary to rear a certain number of individuals (Table 51).

**Table 51:** Number of fish necessary for broodstock replenishment.

Age	Number of individuals
Fingerlings, 1.5–3 g	160–200
yearlings	16–24
1 year +	8–12
2 year +	4

#### 11.4 REARING OF BROODSTOCK IN CAGES

It is wise to start cage rearing of sturgeon when fry reach a weight of 15–30 g. Cages of various sizes and of 2.5–3.5 m in height, made of fine-mesh nets or stainless steel (including the 2–2.5 m submerged part) are used for rearing of sturgeon fry (Figure 113).

**Figure 113:** Cages made of (A) fine-mesh nets (B) stainless steel.



Cages are attached at pontoons in the water unit (Figure 114), where current velocity amounts to 0.2–0.5 m/s. The water temperature in the unit should not be higher than 26–28 °C. Only short-term (1–2 d) temperature elevation up to 30°C is permissible.

**Figure 114:** Sturgeon cage complex (Bulgaria).



#### 11.4.1 Types of cage

The following types of cage are distinguished:

- bgrow out – for rearing junior replacement groups (yearlings – two-year-old fish), with an area of 20–30 m<sup>2</sup> and a mesh size of the wall and bottom cloth of 3–4 mm;
- fattening – for rearing senior replacement groups and holding of immatures and domesticated broodstock, with an area of 20–100 m<sup>2</sup> and a mesh size of the wall and bottom cloth of 12–16 and 3–4 mm, respectively;
- overwintering – for winter holding of different age-graded fish, with an area of 15–20 m<sup>2</sup> and a mesh size of the wall and bottom cloth of 9–12 and 3–4 mm, respectively. The bottom and upper part of the cage should be tightly fastened to the frame;
- quarantine cage – for sanitary and prophylactic operations, typically installed at the end of the cage line or at a separate pontoon downstream.

#### 11.4.2 Cage rearing of fry and replacement stock

Cage stocking density depends upon the mean individual weight of the fish and the period of holding (Table 52).

**Table 52:** Fish stocking density in cages depending on the mean individual weight.

Mean weight, g	Stocking density, kg/m <sup>2</sup>	
	At the beginning of rearing	At the end of rearing
30	1.5–3	10
200	8–10	25–30
1.000 and above	10–12	25–30
Overwintering, regardless of weight	30	

The monitoring of pH, thermal and oxygen regimes should be constantly performed. Overgrowth on the cage walls should be also controlled to avoid reduced flow through the cage, which can hamper the removal of metabolic wastes and negatively impact hydrochemical and gas regimes. The period between cleaning operations depends on the rate of cage overgrowth.

The maximum commercial fish density in cages, established at water units with sufficient current velocity and water saturated with oxygen is 40–45 kg/m<sup>2</sup>. The sorting and separation of fish is performed to adjust to this range. It is expedient to hold the senior replacement at a two-fold lower density than that of commercial fish. The mean survival rate of fish at a rearing weight range of 0.2–2.5 kg is 85–90 percent.

### 11.4.3 Cage holding of broodstock

Cages of larger area (20–100 m<sup>2</sup>) and depth (3–3.5 m) are used for broodstock holding. The initial stocking density of broodstock in ponds is 5–10 kg/m<sup>2</sup>, while the maximum density is 25 kg/m<sup>2</sup> (Figure 115).

**Figure 115:** Pontoon cages for broodstock holding.



Feed is administrated on the basis of 1.5–2 percent of body weight. Note that after the grow-out period (and first spawning), the weight of females tends to decrease. The 12-month weight loss ranges from 8–10 percent.



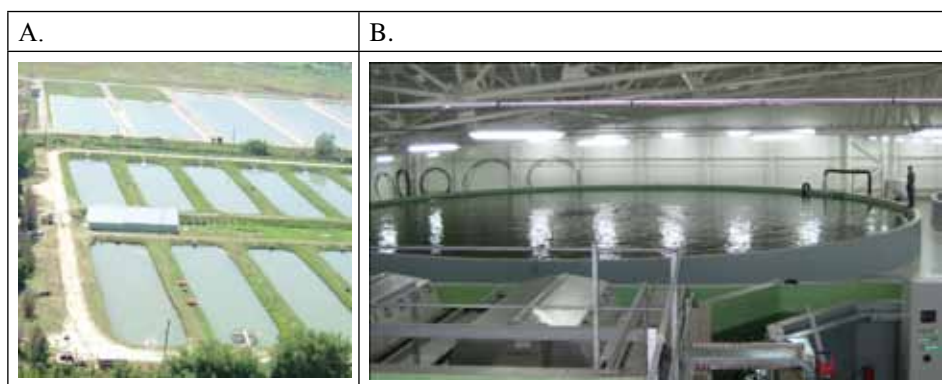
#### 11.4.4 Overwintering of fish in cages

Overwintering of all age groups may be performed directly in cages. Prior to transition to overwintering ponds, it is wise to perform preventive treatment of fish (e.g. baths with salt solution or methylene blue). The overwintering of domesticated broodstock can also be conducted in overwintering cages. Fish of different species should be held separately, with stocking densities as follows: Russian and stellate sturgeon – 20–30 kg/m<sup>2</sup> and beluga – 15–20 kg/m<sup>2</sup>. Weight losses in wild breeders are recorded in all species and during all periods of “domestication” (adaption to captive holding conditions) during the first two overwinterings; in the case of beluga, these losses amount to 3.4–4.5 percent of the body weight, while in Russian and stellate sturgeon they amount to 2–6 percent. The survival rate of domesticated fish during the overwintering period is 95–98 percent.

#### 11.5 PECULIARITIES OF BROODSTOCK HOLDING AND HANDLING

The broodstock should be held in a special unit (plot) having a separate water supply (Figure 116). Each species, as well as each intraspecific and age group should be held separately.

**Figure 116:** Different hatchery units for sturgeon broodstock holding: **A** – small flow-through ponds; **B** – concrete tanks for holding breeders in a recirculating system (project Billund Aquakultur Service ApS (Denmark) and Aquafuture (Germany)); **C** – photo of the unit for brood fish holding; **D** – digital layout of the unit for broodstock holding; **E** – layout of the unit for broodstock holding (photos B, C, D and E provided by D. Firzloff, Aquafuture).



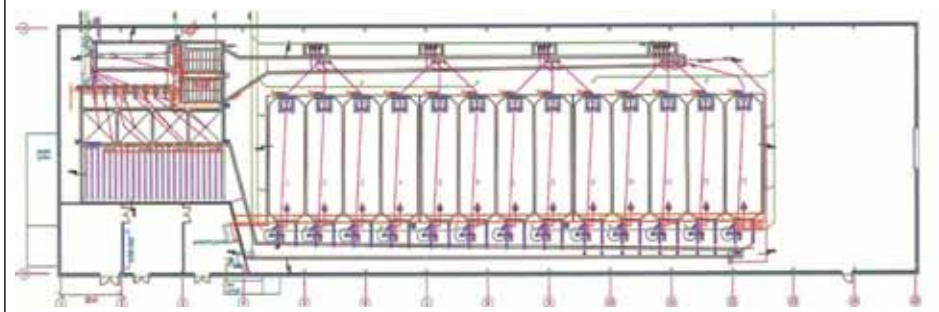
C.



D.



E.



Breeders to be used in the spawning season (campaign) should be held at the adaptation unit for two to three months under conditions that ensure the minimal influence of stressors (i.e. low stocking density, natural photoperiod, minimum influence of ambient factors, optimal hydrochemical parameters and water supply). Such fish are subjected to adaptation procedures, including sanitary operations to prevent inflammation (FAO, 2008b). A summary of the approximate rearing standards for sturgeon replacement stocks and broodstocks in tanks and cages of different types is given in Tables 53 and 54 (Chebanov, Galich and Chmyr, 2004).

**Table 53:** Summary of standards for junior broodstock replacement rearing in tanks, cages and small ponds under optimal conditions.

Stocking material weight, g	Tanks	Net cages	Small ponds
<i>Area, m<sup>2</sup></i>			
	5–20	4–25	250–750
<i>Water level, m</i>			
5	0.6	0.8–0.1	–
30	0.8	1.5	–
100	1.0	2.0	1.5–2.0
800	1.2	2.0–2.5	1.5–2.0
800–1 500	1.5	2.5	1.5–2.0
<i>Stocking density, kg/m<sup>2</sup></i>			
5	5	–	–
30	7	6	–
200	9	7	3
400	10	8	4
800	12	9	5
<i>Feeding frequency, times per d</i>			
< 200	8	6	6
< 1 500	6–8	6	6
<i>Water demand (liters per kg mean body weight of fish) at 22 °C in tanks at an oxygen level of about 100 % saturation</i>			
5	0.101		
30	0.059		
100	0.039		
200	0.031		
400	0.012		
800	0.009		
1 500	0.007		

<i>Survival rate, %</i>			
5	80	–	–
30	85	80	80
200	95	90	85
400	95	90	95
800	95	95	95

**Table 54:** Summary of standards for senior replacement and broodstock rearing in tanks, cages and small ponds under optimal conditions.

<b>Stocking material weight, kg</b>	<b>Tanks</b>	<b>Net cages</b>	<b>Pond-type cages</b>
<i>Area, m<sup>2</sup></i>			
	20–40	10–50	250–1 500
<i>Water level, m</i>			
	1.5	2.0–4.0	1.5–2.5
<i>Stocking density, kg/m<sup>2</sup></i>			
1.5–3.0	15	10	6
3.0–4.0	18	12	7
4.0–6.0	25	15	8
6.0–10.0	30	25	9
>10.0	40	30	10
<i>Survival rate, %</i>			
	98	98	98
<i>Water demand (liters per kg mean body weight of fish) at 22 °C in tanks at an oxygen level of about 100% saturation</i>			
1.5	0.0070		
3.0	0.0057		
4.5	0.0049		
6.5	0.0046		
10.0	0.0045		
>15.0	0.0039		

## 11.6 GENERAL RECOMMENDATIONS ON BUILDING BROODSTOCK SEXUAL STRUCTURE

The sexual structure of the broodstock should correspond to the objectives of broodstock holding. The age at sexual maturity and the generation intervals (for males and females) should be considered in the course of determining the sexual structure for broodstock development. The sexual structure of broodstocks should be built without cross-breeding. The minimum population size of a captive broodstock (and of its spawnable part) has been determined to be 100 individuals (at inbreeding coefficient  $F = 0.5\%$ ), while the optimum size is 500 (FAO, 2008).

A general principle for the development of a proper sexual structure for the broodstock is the holding of the minimum number of males to match broodstock establishment by means of culling of males and sperm cryopreservation (in order to obtain efficient population size when collection of wild males is impossible). To achieve the proper economical efficiency and optimal size of broodstock, the target male-to-female ratio for each generation should be established before the fish reach maturity.

## 11.7 BROODSTOCK BUILDING IN STURGEON PEDIGREE FARMS AND HATCHERIES

The size of replacement broodstock is typically restricted by the capacity of an individual fish farm. The size of the gene pool replacement broodstock should be related to the number of broodstock that leave viable offspring. The effective population size ( $N_e$ ) is determined by the number of crossing animals at inbreeding speed equal to  $0.5 N_e$  (FAO, 2008).

$$N_e = \frac{4(N_f \times N_m)}{N_f + N_m}$$

where,  $N_m$  and  $N_f$  = number of males and females, respectively.

Strictly speaking, to conserve the gene pool at broodstock construction, it is wise to consider the frequencies of rare alleles. The size of replacement broodstock is determined by the number of effectively crossing animals. The list of the most typical deviations in terms of effective broodstock size comprises:

- biased sex ratio (number of males  $\neq$  number of females); and
- different numbers of mating males and females in following generations.

Therefore, the optimal for selective breeding programmes in a living gene bank is a sex ratio of 1 female (F):1 male (M), not only for the whole stock, but also for each generation (Annex IV). In contrast to the living gene bank, the effective size of the broodstock in a multiplying pedigree sturgeon farm or in a sturgeon hatchery should be built in the spawning part of the broodstock; in this case, both

age at sexual maturity and variation in the generation (interspawning) intervals are to be considered. For example, for sterlet broodstocks developed at a hatchery with a natural temperature regime that allows the obtaining of mature females and males at the age of five and three years, respectively (average generation interval in females is two years, while for males, it is one year), the broodstock sex ratio should be of 2F:1M (Petrova *et al.*, 2001). Considering that males reach their maturation two years earlier than females, two elder generations of sturgeon brood fish should be female monosex, and respectively, two male generations are to be transferred from replacement to broodstock two years earlier than females.

The sexual structure of the stock should be corrected once fish reach the size and weight values given in Table 55, with the use of the express ultrasound technique of sexing and staging.

**Table 55:** Minimal weight and age requirements for different sturgeon species, when their sex can be noninvasively identified by ultrasonography (modified from Chebanov and Galich, 2009).

Species (hybrid)	Warmwater fish farms		Hatcheries with natural conditions	
	Weight, kg	Age, year	Weight, kg	Age, year
Russian sturgeon	2.0 – 2.5	1+ – 2	2.0 – 2.5	2+ – 3
Beluga sturgeon	7.0 – 10.0	3 – 4	8.0 – 12.0	4 – 5
Stellate sturgeon	2.0 – 2.5	2 – 2+	2.0 – 2.5	2+ – 3
Sterlet	0.3 – 0.5	1 – 1+	0.3 – 0.5	1+ – 2
Ship sturgeon	2.0 – 2.5	2 – 2+	2.0 – 2.5	2+ – 3

The final sex ratio and number of individuals should be determined by the reproductive part of the broodstock. The broodstock reserve should be composed of not less than 30 percent females and 10 percent males.

## 11.8 OPTIMUM TEMPERATURE CONDITIONS FOR STURGEON BROODSTOCK MANAGEMENT

### 11.8.1 Seasonal temperature regime for holding of senior replacement groups

An important factor for the normal development of the sturgeon reproductive system is a seasonal temperature regime for holding the senior replacement groups (Petrova, 1978). Rearing of replacements in warm water with year-round feeding allows maturation of breeders 1.5–2.5 times earlier, considerably reducing generation intervals (Table 56). Thus, prior to vitellogenesis, it is essential to hold the replacement group under optimal (for growth) temperature conditions (i.e. in warm water). While rearing breeders, it is necessary to introduce into the holding cycle a period of maintenance at low temperatures – “overwintering” at the age that is defined for each species with obligatory food deprivation.

**Table 56:** Age at maturation and optimal time of replacement stock transition to natural temperature regime.

Species	Age, years			
	First maturity		Transition of replacement stock to holding at natural temperature regime, years	
	Males	Females	Males	Females
Russian sturgeon	3–4	6–8	2–3	4–5
Stellate sturgeon	3–4	5–7	2	3–4
Beluga sturgeon	5–8	9–12	4–5	7–9
Ship sturgeon	4–5	5–7	3–4	4
Sterlet	2–3	3–5	2	2

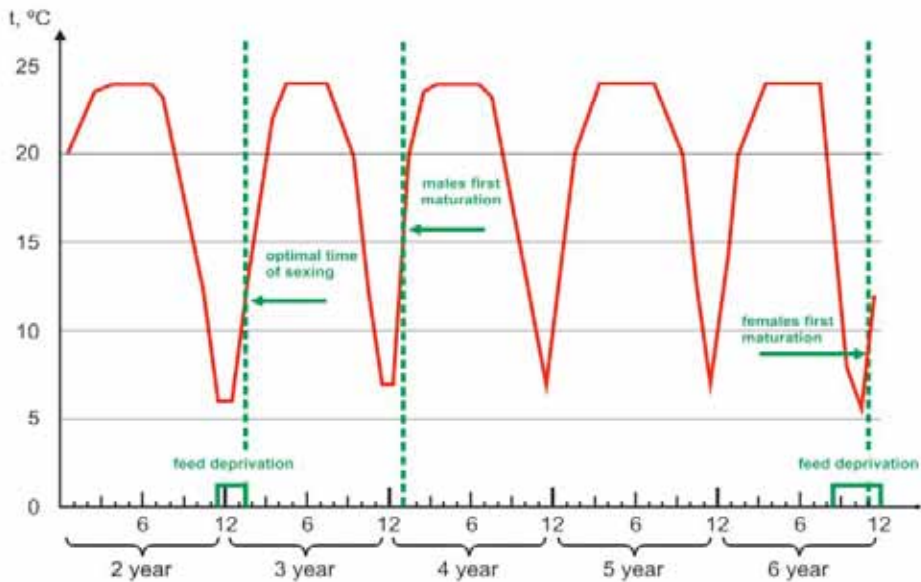
Constantly high temperatures and feeding may result in obesity of the sturgeon and in a considerable delay of their final maturation; even upon reaching stage IV of gonad maturity by females, the production of viable eggs (oosomatic index) may be very low. A similar example for a Siberian sturgeon female maintained at a constantly high temperature (13–23°C) and feeding may be seen in Figure 117.

**Figure 117:** Gonads of “mature” female Siberian sturgeon held under conditions of constant high temperature and feeding.

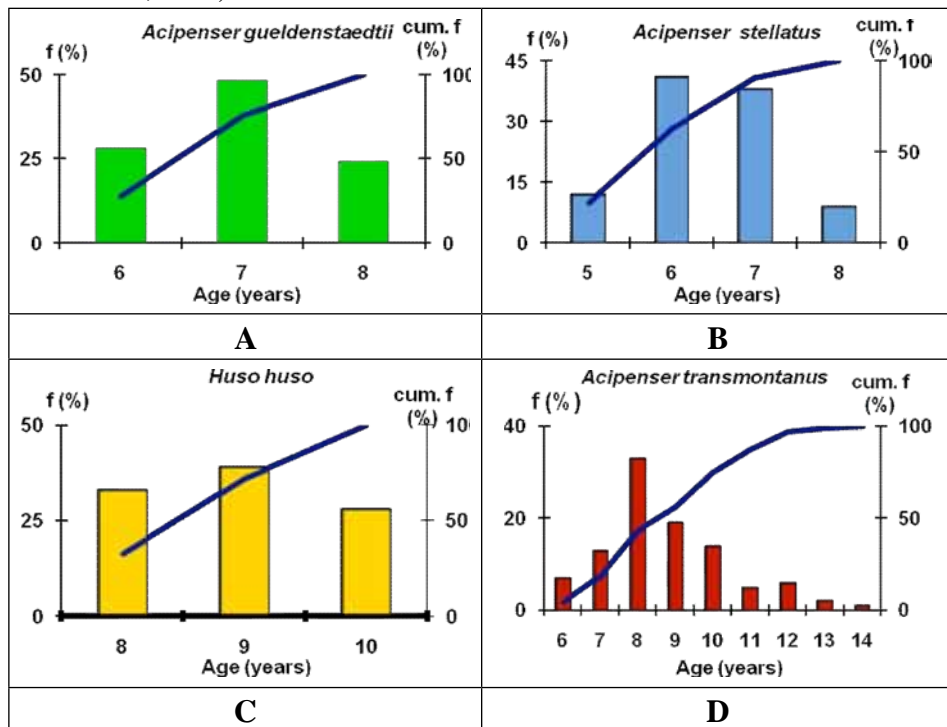




**Figure 118:** Optimal temperature regime for broodstock management of Russian sturgeon.



**Figure 119:** The age at puberty in cultured sturgeon females: **A, B, C** – under optimal rearing condition with thermoregulation (Chebanov, Galich and Chmyr, 2004); **D** – at constant temperature of 20 °C (Doroshov, Moberg and Van Eenennaam, 1997).





Considering the above, the optimum temperature conditions for broodstock holding as exemplified by Russian sturgeon are given in Figures 118 and 119 and Table 57.

**Table 57:** Age at maturation and duration of successive cycles of gametogenesis in wild and farmed sturgeon breeders (Chebanov, Galich and Chmyr, 2004).

Species	Age at puberty, years				Generation intervals, females, years	
	Males		Females		Wild	Farmed
	Wild	Farmed	Wild	Farmed		
Russian sturgeon	8–10 (7–10) <sup>1</sup>	3–4	10–14 (8–15)	6–8	3–5	1–3
Stellate sturgeon	5–6 (3–8)	3–4	8–10 (6–13)	5–7	3–4	1–2
Beluga	12–14 (9–14)	5–8	16–18 (11–19)	9–12	≥ 4–10	2–3
Sterlet	3–8	2–3	3–12	3–5	2–3	1–2

<sup>1</sup> Data given in parentheses pertain to Azov populations.

Note that the body weight at puberty and absolute fecundity in farmed fish are lower than those of wild fish (excluding sterlet) (Table 58).

**Table 58:** A comparison of body weight at first maturity and absolute fecundity in wild and domestic sturgeon breeders (Chebanov, Galich and Chmyr, 2004).

Species	Absolute fecundity of females, eggs (x 1 000)		Body weight at first maturity, kg			
			Males		Females	
	Wild <sup>1</sup>	Farmed	Wild <sup>1</sup>	Farmed	Wild <sup>1</sup>	Farmed
Russian sturgeon	121–490	45–185	6–10	2–3.5	9.9–18	7.4–14.0
Stellate sturgeon	150–379	43–145	2.1–5.6	1.5–3.4	4.4–13.7	5.4–9.0
Beluga sturgeon	355–3 600	250–550	35–89	18–27	71.0–150	32.0–65.0
Sterlet <sup>2</sup>	4.5–150	7.5–120	0.3 <sup>2</sup> –1.2	0.3 <sup>2</sup> –2.3	0.3 <sup>2</sup> –2.5	0.3 <sup>2</sup> –2.5

<sup>1</sup> These data relate to Azov populations.

<sup>2</sup> Indicated values (lower range limits) pertain to Siberian sterlet.

The values of relative fecundity in farmed fish are close to or higher than those in wild fish, usually due to smaller oocyte size (Table 59).

**Table 59:** Reproductive indices in wild and domestic sturgeon breeders (Chebanov, Galich and Chmyr, 2004).

Species	Oosomatic index		Relative fecundity, eggs (x 1 000)/kg female body weight		Egg weight, mg	
	Wild	Farmed	Wild	Farmed	Wild	Farmed
Russian sturgeon	0.12–0.27	0.12–0.25	6.6–18.5	7.8–15.0	17.8–31.3	12.8–23.9
Stellate sturgeon	0.10–0.22	0.11–0.20	13.3–24.6	12.5–18.5	9.6–14.2	8.7–14.1
Beluga sturgeon	0.10–0.18	0.12–0.15	6.6–7.2	5.4–8.2	25.1–37.8	20.3–29.4
Sterlet	0.12–0.22	0.11–0.23	12.5–17.6	12.1–22.5	6.6–12.5	5.9–11.2

### 11.8.2 Relationship between rate of sturgeon maturation and thermal regime of holding (sum of the effective temperatures)

The rate of the generative processes in fish depends primarily on the temperature of holding (Kazansky, 1975). In calculating the sum of effective temperatures (in o d), only the period of holding fish at “effective temperatures” should be considered. Effective temperatures refers to the temperature from the spawning optimum until the temperature at which fish stop to feed.

When building a sturgeon broodstock, the following two values should be considered for each species:

- the sum of the effective temperatures to reach sexual maturity; and
- the sum necessary for a completion of one gametogenic (reproductive) cycle (Table 60).

**Table 60:** Sum of the effective temperatures necessary for the first and subsequent maturations of sturgeon females.

Species	Sum of effective temperatures necessary for first maturation		Generation intervals (females), °d
	Males	Females	
Russian sturgeon	10 000–10 500	17 000–27 000	5 200–8 000
Stellate sturgeon	10 000–10 500	17 000–23 000	4 900–6 500
Beluga sturgeon	17 000–25 000	28 000–36 000	6 900–12 000
Ship sturgeon	9 000–12 000	19 000–29 000	6 000–8 500
Sterlet	6 000–9 000	12 000–13 000	2 800–4 200

Thus the use of the “sum of the effective temperatures” index allows spawning of breeders to be more accurately predicted in terms of the specific situation of an individual hatchery or for optimization of monitoring of the temperature regime. Although the sum of the effective temperatures is a rather universal characteristic, it is not the only factor determining the age at maturity and generation intervals. At excessive density, as well as scarce or excessive feed ration and not following the recommendations on overwintering, the maturation of breeders tends to be prolonged, which can cause considerable disturbance of gonadogenesis. The recovery of the reproductive quality of such fish may be impossible or may require long-term and complicated treatment.

## 11.9 MORPHOLOGICAL ABNORMALITIES IN DEVELOPMENT OF REPLACEMENT AND DOMESTIC BROODSTOCK

Since the majority of factors influencing natural selection in wild populations (e.g. feeding competition, pressure from predators, environmental conditions, etc.) are not present under aquaculture conditions, a portion of the replacement fish and broodstock will display various developmental abnormalities.

### 11.9.1 Abnormalities of the olfactory organs

Abnormalities of the olfactory organs due to malformations of development may occur (Figure 120). These include the absence of a septum between the nostrils, abnormalities of the olfactory rosettes and the absence of the olfactory epithelium (Section 5.2.5.3). The main causes of their appearance are increased water temperature during and post embryogenesis. In this case, the above abnormalities occur frequently in hatchery-produced juveniles and are specific tags of their “artificial origin”.

**Figure 120:** Abnormalities of the olfactory organs: **A** – Russian sturgeon; **B** – Beluga sturgeon; **C** – ship sturgeon; **D** – sterlet.



### 11.9.2 Abnormalities of the eyes

Underdevelopment or the lack of one or both eyes may occur (Figure 121). When sturgeons are reared industrially (i.e. in closed systems, cages or tanks), the presence of this abnormality usually does not reduce their survival ability, since the eyes are not of decisive importance in food competition. However, it is necessary to note cases in sturgeon where a characteristic lack of eyes was passed on to the progeny; for example, in 1997, 30 percent of the progeny of a blind female beluga was comprised of individuals having one underdeveloped eye or having no eyes at all (Chebanov, Galich and Chmyr, 2004). To avoid this problem, such individuals must be rejected at the early stages.

**Figure 121:** Underdevelopment of eye(s): **A** – Beluga sturgeon; **B** – sterlet.



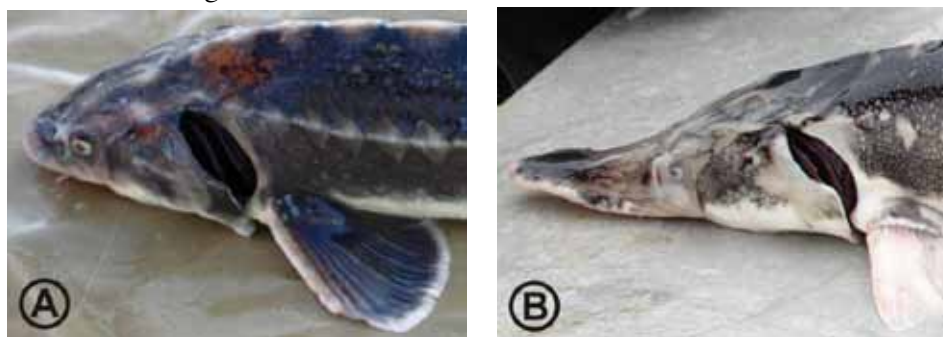
### 11.9.3 Underdeveloped pectoral fins

Underdeveloped pectoral fins (or their complete absence) on one or both sides are more often than not the consequence of injury to the larvae caused by other fish upon the transition to exogenous feeding.

### 11.9.4 Shortened opercula

In cases of shortened opercula, the branchial cavity is not completely closed, the gills remaining exposed (Figure 122). Some authors (Chebanov, Galich and Chmyr, 2004) consider underdevelopment of the opercula to be a consequence of domestication. The rearing of fish with underdeveloped gill covers is not wise, due to their very low survival rate. Individuals with this abnormality exhibit poor response to any fish-farming manipulations carried out at low or very high air temperatures or at water temperatures approaching the critical level.

**Figure 122:** Malformations of opercula (shortening): **A** – Russian sturgeon; **B** – stellate sturgeon.



### 11.9.5 Phenodeviations

Of quite another character are such abnormalities as the presence of an additional pair of fins and underdeveloped pelvic fins (right up to their complete absence) (Figure 123), which belong to the group of so called “phenodeviants” (Podushka and Shebanin, 1996). These abnormalities vary in their manifestation and frequency of departure from normal occurrence and are an indicator of the weakening (i.e. degeneration) of the genetic constitution. The occurrence of phenodeviants bears witness to the need for corrections in selection work and the establishment of stricter control over the selection of spawner pairs.

**Figure 123:** Phenodeviants of the sterlet: **A** – normal pelvic fins are absent, there is a supplementary pair of fins in rudimentary condition; **B** – presence of a supplementary pair of fins in rudimentary condition (Chebanov, Galich and Chmyr, 2004).



It should be noted that among the deviations in development, the concrecence of barbels in pairs is encountered; moreover, the barbels grow together by their ends rather than by the bases. This abnormality is most probably the consequence of the deep disorder of development in early ontogenesis. When reared under artificial conditions, the survival ability of phenodeviants does not differ from that of normal individuals; however, when assessments are carried out, they should be excluded from reproduction.

## 11.10 GENETIC TESTING OF BROODSTOCK: GENETIC CONTROL OF BROODSTOCK MATERIAL

Genetic testing of broodstock should be performed by molecular genetic methods using nucleotide sequences of mitochondrial DNA (mtDNA) analysis, nuclear DNA analysis using random primers (random amplified polymorphic DNA (RAPD) analysis) and amplified fragment length polymorphism (AFLP). Through the use of DNA fingerprinting, not only the origin of fish may be determined, but also the heterozygosity of the broodstock of different species; and the genetic distances between the populations may be estimated.

To carry out individual testing of those individuals reaching sexual maturity, tissue samples consisting of a piece (1–2 g) of back fin fixed in 96 percent ethyl alcohol are collected. An individual number is assigned to each sample, and the fish from which the sample of tissue has been taken is marked by an individual tag (passive integrated transponder (PIT) tag). Traditionally, the analysis of tissue samples is carried out by four microsatellite loci (Table 61).

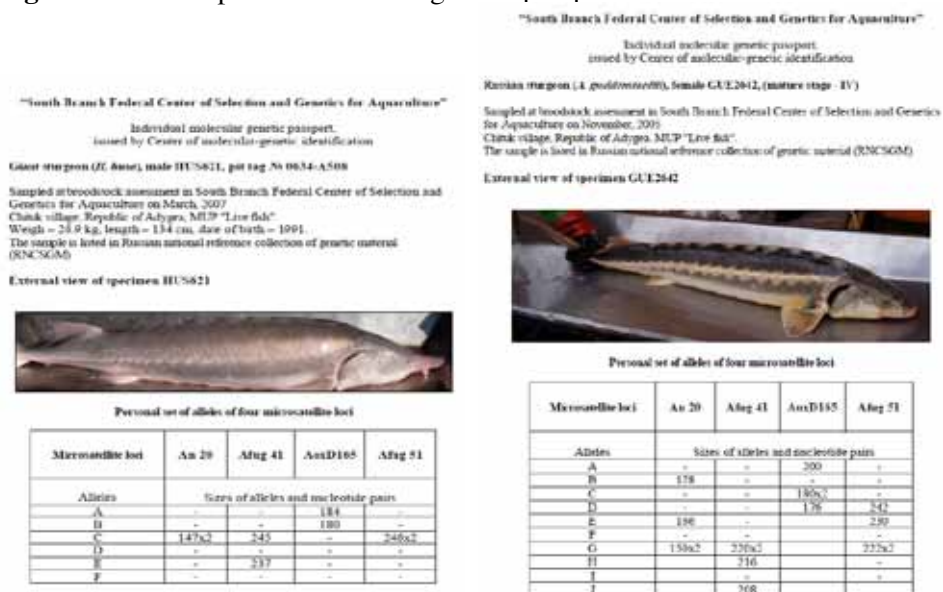
Based on the analysis of the electrophoregrams for each of the loci, the alleles characteristic of the investigated individuals are revealed. To determine the genotype of an individual sturgeon, the number of alleles on each of the loci is counted separately.

Based on the results of the investigations, an individual genetic passport (Figure 124) that includes the number on the individual PIT tag, the data on origin, size and weight parameters, the results of genetic testing and a photo of the fish is drawn up for each fish becoming a breeding part of the stock.

**Table 61:** Microsatellite loci applied for individual certification of sturgeon.

Lokus	Primers 5'– 3'
An20	F:AATAACAATCATTACATGAGGCT R:TGGTCAGTTGTTTTTTTATTGAT
AfuG41	F:TGACGCACAGTAGTATTATTTATG R:TGATGTTTGCTGAGGCTTTTC
AfuG51	F:ATAATAATGAGCGTGCTTTCTGTT R:ATTCCGCTTGCGACTTATTTA
AoxD165	F:TTTGACAGCTCCTAAGTGATACC R:AAAGCCCTACAACAAATGTCAC
AoxD161 <sup>1</sup>	F:CATTCAGTATGAGACAGACACTC R:ATCTCAGGGACTGCTGTGATTGG

<sup>1</sup>Recently, the additional locus AoxD161 has been added for more accurate genetic certification (Mugue and Barmintseva, 2009).

**Figure 124:** Examples of individual genetic passports.

## 11.11 ADAPTATION OF WILD FISH TO ARTIFICIAL HOLDING CONDITIONS

### 11.11.1 Technological scheme of wild fish adaptation

Maximizing the adaptation of breeders and immature fish captured in the wild to hatchery conditions (including maturation in freshwater and feeding with artificial feeds) is one of the key elements of broodstock establishment (i.e. successful hatchery practices) and sturgeon genetic diversity.

The adaptation operation is especially efficient in the case of small effective size of the captive broodstock, and is also related to wild fish with rare genotypes. The technological scheme for adaptation of wild fish to artificial conditions comprises the following elements:

- *in vivo* collection of gametes from breeders;
- transition to artificial feeds;
- holding at a hatchery until the next maturation; and
- exploitation of mature breeders.

The process of fish adaptation to hatchery conditions should be started from their holding in a separate adaptation unit at low temperatures (10–15 °C) and a high level of oxygen to ensure minimal effects of stressors. The water temperature drop enables a decrease in metabolic rate in the organism and hence,



lessens the energy waste associated with the period of adaptation to the artificial environment (e.g. limited volume, flowage, etc.). It is important to minimize the effect of various external stressors (e.g. noise) and maintain lighting close to natural levels.

### **11.11.2 Transition of wild fish to artificial feeds**

Transition to artificial feeding has proved to be the most complicated element of fish adaptation and should be performed gradually. At first, the fish should be trained to natural feeds (e.g. fish, molluscs, worms, crustaceans) under artificial holding conditions (i.e. in tanks or cages) with gradual transition to paste mixtures containing animal components and complex feeds. Artificial feeds should be introduced into the natural paste-like feeds (i.e. fish, mussel, shrimp mince meat, etc.), initially as a powder at low content (< 5 percent). Once the fish start to consume this mixture the content is gradually elevated with a corresponding increase of pellet size. It is a good practice to place feeding specimens from the broodstock with the adapting fish in order to stimulate consumption of paste-like feeds. Fish that do not start to feed naturally should be force-fed with paste-like feeds via a tube, initially with additives and then exclusively by use of pelleted feeds with diluents. The forced feeding should be administered once every three days or less often. In some cases, one forced feeding may be sufficient to adequately start feeding. This is why fish are to be fed with paste-like feeds in tanks (or cages) prior to the recurrent forced feeding, while adequately feeding fish should be selected or tagged and deprived of refeeding (Chebanov, Galich and Chmyr, 2004). The use of attractants and taste stimulants is recommended for better adaptation of the fish to the artificial feeds (Kasumyan and Døving, 2003).

Performance of the adaptation operations may be enhanced by administration of vitamins. For this purpose, vitamins C (ascorbic acid) and E ( $\alpha$ -tocopherol) may be used, as they play important roles in the vital activity of the organism, stimulating lipid, protein and mineral metabolism.

Due to the fact that feed is the main source of these vitamins, the fish suffer a sharp lack of them during the period of their adaptation to artificial conditions. This causes lowered appetite and leads to fluid overload, muscle atrophy and higher risk of infection. An effective diurnal dose of vitamin injections is 5–10 mg of ascorbic acid and 10–15 mg of  $\alpha$ -tocopherol per kg of breeder weight. The recommended duration for administration of injection is 5–7 d. During the period of training fish to feed, they should be kept at a temperature of 12–15 °C, due to the rapid weight loss that is typical for starving individuals exposed to higher temperatures. Under such conditions, their physiological state can be impaired, causing irreversible dystrophy.

Note that sturgeon species in the natural environment exhibit different nutritional preferences; thus diet composition during the adaptation period should be species specific (Table 62).



**Table 62:** Requirements for the composition of paste-like feeds used for domestication of captive sturgeon broodstock.

Species	Ingredients	
	attracting	deterrent
Russian sturgeon	Sea fish Mussels (e.g. swan mussel zebra mussel) freshwater shrimp	Freshwater fish Fish flour Fish oil
Beluga sturgeon	Sea and freshwater fish Fish flour Fish oil	Unknown
Stellate sturgeon	Oligochaetes Chironomids Freshwater shrimp	Sea and freshwater fish Fish flour Fish oil
Sterlet	Ordinary fish eggs Oligochaetes Chironomids Freshwater shrimp	Sea and freshwater fish Fish flour Fish oil

The overall duration of adaptation to artificial holding conditions may vary from 40 to 85 d, depending on the fish species, holding condition, feed ingredients and scheme of operation. Beluga shows the most rapid adaptation to artificial conditions; there also exist some additional data on the successful transition of stellate sturgeon to artificial feeds within 39 days (Memiş, Ercan and Yamaner, 2011).

For repeated ovarian maturity, domesticated females may need not only to recover energetic and plastic losses by wintering, spawning run, holding, wound regeneration and feeding adaptation, but also accumulate a sufficient trophy-plastic (fat-protein) deposit for new generations of oocytes.

After egg extraction from “domesticated” wild females, the next maturation could occur after 4–7 years of holding in captivity at natural temperature regime (Shevchenko, Popova and Piskunova, 2004). After collection of gametes from females, during the first grow-out season, the fish weight tends to decrease: in beluga up to 15 percent, while in Russian and stellate sturgeons – up to 13.5 percent. The maximum growth gain is recorded during the second and third years of the interspawning interval. Towards the end of the second year of holding of operated females, the degenerative processes in the gonads are going on, as is evident from the occurrence of pigment granules. The onset of oogonial proliferation and the development of new cell generation is observed in the ovaries. The large oocytes with yolk granules are evident in the ovaries of Russian and stellate sturgeons (Popova, Piskunova and Shevchenko, 2004). The length of the generation intervals can be reduced by warmwater holding of the fish and their transfer to artificial diets with year-round feeding during the first 1–2 years (Shevchenko, Popova and Piskunova, 2004).

## 11.12 TRANSPORTATION

The transportation of fish, either within the hatchery or between different farms is a necessary element of hatchery technology. General principles of health management for responsible movement of live aquatic animals are described in FAO (2007). Transportation of fish or eggs may be performed in hermetic (airtight) or open containers. Despite the type of container, the main criterion for successful fish transportation is proper stocking density, which depends upon the size, age and species of the fish and the intensity of metabolism at the selected transportation temperature regime. Feeding of the fish selected for transportation should be stopped not less than 30 h prior to the start of loading.

### 11.12.1 Transportation in hermetic containers

Plastic bags of standard (20–40 liter) or larger volume, as well as cisterns made of rubberized fabric or other similar material are used as hermetic containers for fish transportation. Plastic bags are routinely used for transportation of fertilized eggs, larvae and fry, but in some cases they can be used for large fish. Bags are made of a single piece (95 cm) cut from a thick (0.07–0.15 mm) plastic (sleeve) of 50–80 cm width, one side of which is welded by a V-shaped seal and the other made airtight by use of a special clip (clamp) or rubber clamping rings. Bags are made double-layered in order to ensure their reliability. The ratio of water (with fish) to free space in the bag should be 1:3. Then air should be released from the bags and oxygen pumped into them. The bags are then sealed hermetically by one of the above mentioned ways and placed in a box covered with heat-insulating material (padded polyester, foam plastic, etc.).

Fish in packed bags may be transported for up to 24–30 h. During transportation, it is necessary to provide mixing of the water in the bags to ensure a proper oxygen regime. During the hot season of the year, boxes with bags should be protected from direct sun light, and considerable water temperature elevation prevented by the use of airtight containers with ice. During transportation the bags should be in a vertical position, while during long stops, they should be placed horizontally. If the transportation takes more than 30 h, the oxygen reserve in the bags should be renewed. The stocking densities at 15 °C are shown in Table 63. At higher temperatures, a lowering coefficient of 0.25 per each 5°C should be used, while at lower temperatures, a similar elevated coefficient is used.

**Table 63:** Loading densities (kg) for transportation of sturgeon larvae, fry and fingerlings in plastic bags (Orlov *et al.*, 1974).

Individual weight, g	Duration of transportation at 15 °C water temperature, h									
	5	10	15	20	25	30	35	40	45	50
0.01–0.03	0.15	0.15	0.15	0.15	0.15	0.15	0.15	0.15	0.14	0.12
0.2	0.2	0.2	0.2	0.2	0.18	0.15	0.13	0.12	0.1	0.09
0.5	0.3	0.3	0.3	0.27	0.21	0.18	0.15	0.13	0.11	0.1
1.0	0.5	0.5	0.5	0.4	0.32	0.27	0.23	0.21	0.18	0.16
2.0	0.7	0.7	0.53	0.4	0.32	0.27	0.23	0.21	0.18	0.16
5.0	1.0	1.0	0.7	0.5	0.4	0.33	0.29	0.25	0.23	0.2
10.0	1.5	1.0	0.7	0.5	0.4	0.33	0.29	0.25	0.23	0.2
20	1.8	1.0	0.76	0.57	0.46	0.38	0.33	0.28	0.25	0.23

At determination of optimal stocking density, not only fry oxygen demand should be considered, but also the threshold level of dissolved carbon dioxide that can cause fish mortality. For larvae ranging from 10–30 mg in weight, this level is 40 ml/liter, while for larger fry, it is 20 ml/liter. At 15 °C, the mean release of carbon dioxide by fish is 150–200 ml/kg/h, while at 20 °C, it is 300–450 ml/liter/h.

### 11.12.2 Transportation of sturgeon fertilized eggs

During transportation it is essential to avoid prolonged holding of the egg bags in a stable (motionless) state, both during stopping and in the course of packing and unloading of eggs. The duration of possible holding of eggs in a stable state depends upon the density of loading in the bags and the water temperature and ranges from 10–15 min on average at a density of 5–6 kg per bag, and 1–1.5 h at 2–2.5 kg per bag (both at 15–17 °C). At low loading densities (1 kg and less) and optimal transportation regime, the time of egg tranquility can reach 2–3 h. A light, 40–60 s shaking of the bags every 40 min is recommended in the case of long-term stops. Exceeding the above-mentioned time of egg tranquility may cause their mass mortality, which can reach 50 percent. The optimal loading density of fertilized eggs in bags depends of their development stage, the temperature regime and the transportation duration (Table 64). During transportation, the water temperature should be within the species-dependent range.

**Table 64:** Norms for loading of sturgeon fertilized eggs for transportation in plastic bags at different temperatures (kg) (Orlov *et al.*, 1974).

t, °C	Duration of transportation, h							
	5	10	15	20	25	30	35	40
At stages from early gastrulation to lateral plates fusion								
10	6.0	6.0	6.0	5.3	4.5	3.9	3.4	3.1
15	6.0	6.0	4.8	3.8	3.2	2.7	2.4	2.1
20	6.0	5.6	4.1	3.3	2.7	2.3	2.0	1.8
At stages of rotating embryo								
10	6.0	5.1	3.7	3.0	2.5	2.1	1.8	1.6
15	6.0	4.3	3.1	2.4	2.0	1.7	1.5	1.3
20	6.0	3.7	2.7	2.1	1.7	1.4	1.2	1.0

### 11.12.3 Transportation in open containers

Open containers include flasks, cans (canisters), canvas baths and vats (typically used for in-house transportation), and live-fish cisterns (with or without thermal insulation), fitted to truck transport (Figure 125) and live-fish vans. Transportation of fish in specialized live-fish truck transport should be accomplished by use of constant water aeration and oxygenation. The filling of containers with water is performed immediately before the loading of fish. The aeration system should be operated after the filling of a container (not later than 15 min prior to fish loading).

**Figure 125:** **A** – loading container for short-term fish transportation (volume = 300 liter) (Chepurkina *et al.*, 2008); **B** – specially designed container for short-term transportation of live fish.



A high rate of mucus formation is typical for sturgeon that are being kept out of water (even short-term) and subjected to mechanical stressors. Because of this, after loading, fish should be “rinsed” with running water for 20–30 min to remove separated mucus from the live-fish containers. To reduce the effects of

stressors on fry and adults, it is advisable to add unionized salt (3–5 ‰) during transportation. Throughout the transportation, it is essential to control the water level in the container, the water temperature and the oxygen concentration, which should be 4 mg/liter or above (only a short-time drop to 2 mg/liter is permissible). Stocking densities of sturgeon species in various transport containers are presented in Table 65.

**Table 65:** Stocking densities for sturgeons when using different transportation containers.

Transportation container	Duration of transportation, h	Stocking density, kg			
		Larvae	0+ year old	2-year old	Older age groups
Flasks, canisters (40 liter)	≤ 2	0.5–1.0	5.0		
Canvas vat (2 m <sup>3</sup> )	≥ 2	–	80	120	150
Live-fish cistern (3 m <sup>3</sup> )	3–6	–	300	350	500
	6–12	–	220	240	400
	12–24	–	160	180	300
Live-fish truck (30 m <sup>3</sup> )	24–48 and above	–	1 500	2 500	3 000

## Chapter 12

### Basic sanitary and fish health measures

#### 12.1 BASIC DISEASES OF STURGEON

Sturgeon in the wild are more resistant to various diseases than other fish species, due to their complex life cycles, which involve periods spent in different aquatic environments (marine, brackish, freshwater). Sturgeon are affected by only a few types of disease; fungal, viral, bacterial parasitic, nutritional and environmental diseases (i.e. those associated with noncompliance with the specific environmental requirements of the fish) have been reported in sturgeons.

The majority of sturgeon diseases are similar to those affecting other cultured fishes (carps, trouts, etc.) and are not sturgeon specific. Diagnostics, prevention and treatment of such diseases should be performed using conventional ichthyopathological methods.

Viral-caused diseases are the only exception. At present four families of virus have been recognized from sturgeon: Adenoviridae, Herpesviridae, Iridoviridae and Papovaviridae (Hedrick and LaPatra, 2001). Members of the Herpesviridae and Iridoviridae are the most numerous and serious viruses found in sturgeon.

White sturgeon iridovirus (WSIV) is the best known among the viruses affecting sturgeon. This virus is rather host specific, having been encountered in white sturgeon (*Acipenser transmontanus*) in the United States of America. A similar virus has also been reported in Russian sturgeon (*A. gueldenstaedtii*) in northern Europe. An effective treatment for this virus has not yet been elaborated (Hedrick and LaPatra, 2001).

Saprolegniosis (caused by *Saprolegnia*) is one of the most common fungal diseases of sturgeon. Dead and unfertilized eggs are often attacked by this fungal infection; thus it is essential to provide proper treatment in order to avoid infection of the adjacent live eggs. Apart from direct effects on eggs, saprolegniosis also negatively affects the oxygen level in the incubation systems. For prevention or treatment, use of the following organic dyes and chemicals is recommended:

- malachite green – 1 part:100 000 parts of water (10 mg/liter) for 10 min or 1:200 000 (5 mg/liter) for 15 min exposure;
- methylene blue – 1:10 000 and 1:20 000 (100 mg/liter and 50 mg/liter) for 1 h;
- violet “K” (C<sub>24</sub>H<sub>28</sub>N<sub>3</sub>Cl) – 1: 200 000 (5 mg/liter) for 30 min.

It should be noted that as malachite green is potentially carcinogenic and mutagenic, its use in fish culture is not recommended (it is forbidden in the European Union and some other countries). However, its use may be permissible in the culture of sturgeon intended for restocking (but not for fish

destined for human consumption). Treatment should be conducted not less than two times, at the stages of slit-like blastopore (stage 18) and straightened elongated cardiac tube (stage 28). The collection of dead eggs and those contaminated by *Saprolegnia* can be performed by using a rubber siphon whose diameter is species dependent. An effective technique of prolonged “Violet-K” effect, from incubation until embryo movement (stages 33–34), involves treatment at a concentration not higher than 0.3 mg/liter (Mamedov, 2000). The dosage should be 60–96 drops (7.5–12 ml/min) of standard solution (1.5 g/liter) to maintain a concentration of 0.2–0.3 mg/liter at a water demand in the incubation system of 4.0 m<sup>3</sup>/h.

In order to prevent diseases of larvae and fry, it is good practice to monitor the quality of the water and feeds and to avoid stressors associated with high stocking density and frequent handling (FAO, 2007; Arthur, Bondad-Reantaso and Subasinghe, 2008).

The most deleterious diseases occurring during fry rearing are invasive diseases caused by external parasites (i.e. *Trichodina*, *Diclybotrium*, *Nitzschia*) and bacterial infections. The majority of other parasites and diseases can worsen the physiological state of a few specimens but do not cause mass mortality. In some cases, the infection of eggs by the internal parasite *Polypodium hydriforme* has been observed.

## 12.2 CLINICAL SIGNS OF THE MOST COMMON DISEASES

Clinical signs for the most common diseases of sturgeons during rearing under artificial conditions are shown in Table 66.

In order to conduct timely identification of diseases and prevent their spread, it is essential to perform constant monitoring. Burlachenko and Bychkova (2005) suggested to evaluate and register external clinical signs of disease in sturgeon by the use of special health examination forms (one form for each rearing unit: tank, trough, cage or pond) (Table 67). To evaluate the intensity of such pathology as scute deformities, gill lesions and fin inflammation due to external parasites, a four -point scale (with III indicating the highest level of pathological change) is used. To evaluate characteristics displaying a narrow range of pathological change (such as reduced mucus secretion, anal inflammation and darkening of the gills), it is recommended to apply a three -point scale (0-II).

**Table 66:** Clinical signs of common sturgeon diseases (modified from Matishov, Ponomarev and Ponomareva, 2007).

Disease, agents and causes	Clinical signs
External parasites: <ul style="list-style-type: none"> <li>• Protozoans – <i>Ichthyobodo necatrix</i>, Trichodinidae, <i>Apiosoma</i>, <i>Epistylis</i></li> <li>• Monogeneans – <i>Diclybothrium</i>, <i>Dactylogyrus</i></li> <li>• Crustaceans – <i>Argulus foliaceus</i></li> </ul>	<ul style="list-style-type: none"> <li>• Decreased feed intake</li> <li>• Anxious behaviour, erratic swimming</li> <li>• Crowding at outlet at water surface and at tank walls</li> <li>• Increased mucus formation</li> <li>• Damage to fins and gills</li> <li>• Occurrence of haemorrhagic areas or ulcers on body</li> </ul>
Bacterial diseases: e.g. <i>Flexibacter</i> , <i>Cytophaga</i> , <i>Sporocytophaga</i> , <i>Flavobacterium</i> , <i>Flexibacter columnaris</i> , <i>Aeromonas spp.</i>	<ul style="list-style-type: none"> <li>• Decreased appetite</li> <li>• Sick fish are immobile, float inertly, gathering close to the sides of the pool or at the water drain</li> <li>• Fish become dark or covered with spots (marble colour)</li> <li>• Haemorrhages appear on skin, gills and internal organs</li> <li>• Renal function is impaired; fluid (exudate) accumulates in body cavity</li> <li>• Small fish die quickly without any gross clinical signs</li> </ul>
Fungal diseases: <i>Saprolegnia</i>	<ul style="list-style-type: none"> <li>• Reduced appetite</li> <li>• Loss of mobility</li> <li>• White wadding-like deposit on body surface</li> </ul>
<ul style="list-style-type: none"> <li>• Nutritional diseases (e.g. due to improper or spoiled feeds, fluctuations of water temperature, low oxygen content, shortage of B group vitamins)</li> </ul>	<ul style="list-style-type: none"> <li>• Loss of appetite</li> <li>• Altered swimming behaviour</li> <li>• Pale body colouration</li> <li>• Enhanced mucus secretion</li> <li>• Haemorrhages appear</li> </ul>
<ul style="list-style-type: none"> <li>• Gas bubble disease (GBD). Can result from super-saturation of water by nitrogen (&gt; 104 % for larvae and fry, &gt; 110% for yearlings) and oxygen &gt; 250–350 %)</li> </ul>	<ul style="list-style-type: none"> <li>• Mechanical damage to blood vessels and inner organs resulting in direct fry mortality.</li> <li>• GBD in prelarvae (prior to onset of exogenous feeding) is characterized by formation of gas bubbles in the mouth that hamper transition to active feeding and typically lead to mortality (Golovin, 2001).</li> </ul>



**Table 67:** External clinical signs of some diseases of sturgeons and degree of their manifestation (in points) (Burlachenko and Bychkova, 2005).

Disease (agent)	Clinical Sign					
	Scute deformities	Anal inflammation	Gill lesions*	Reduced mucus secretion	Redness of skin	Fin inflammation
<b>Bacterial diseases</b>						
Myxobacteriosis	I–III	0–I	I–III	I–II	I–II	0–I
Bacterial haemorrhagic septicaemia ( <i>Aeromonas</i> , <i>colon Bacillus</i> , <i>Cyrobacter</i> )	I–II	II	Light	0–I	I–II	I
Bacterial haemorrhagic septicaemia with dominance of <i>Proteus</i>	III	II	Light	0–I	III–II	
<b>Parasitic diseases</b>						
Trichodiniosis	I–II	0–I	I–III	I–II	I	0–I
<b>Monogenoidoses</b>						
Dactylogyrosis	I		III			I–II
Diclybothriosis	I		III			I–II
<b>Noncommunicable diseases</b>						
Nutritional diseases	I–III	II	Hafif			
Methemoglobinemi	I–III	0–I	Yoğun		I–II	

\* gill coloration (light or dark) can be a distinctive clinical sign in case of some diseases.

### 12.3 METHODS FOR TREATMENT AND PREVENTION

Treatment and prophylaxis can be conducted by one of the following methods:

- per os – the preparation is mixed with the feed prior to feeding or a special prophylactic feed is used. Prolonged (>6 h) storage of self-prepared therapeutic feeds is not recommended.
- by bath – the preparation is diluted in water in special tanks or in the containers where the fish are held. The concentration of the preparation in water and the temperature and oxygen regimes have to be controlled during the exposure. The fish quality should be constantly monitored

throughout the treatment. If the state of the fish worsens, the procedure should be stopped and the fish transferred to containers filled with clean water and high water exchange.

- by intramuscular injection – the preparation is administered directly into the body.

## 12.4 PREPARATIONS USED FOR TREATMENT OF STURGEONS

A list of veterinary and prophylactic preparations that are applied to combat various diseases of juvenile sturgeon is presented in Table 68.

**Table 68:** List of veterinary and prophylactic preparations (modified from Hochleithner and Gessner, 1999).

Disease	Preparation	Dosage	Exposure
Bacterial diseases	Antibiotics		
Flexobacteriosis	Oxytetracycline	10–15 g/100 kg fed	10 d
Pseudomonosis	Furazolidone	20 g/100 kg fed	10 d
Aeromonosis	Aureomycin	20 g/100 kg fed	10 d
	Biciline 3 (5)	80 000–100 000 units/kg weight	single
Ectoparasitic diseases	Baths		
Protozoans	Salt (NaCl)	%0.5–1.5	1 h
	Chloramine-T	10–20 ppm	1 h
	Formalin (40 % formaldehyde)	200 ppm	20 min
	Methylene blue	5 ppm	1 h
	Acriflavine (tripaflavine)	10 ppm	10 h
	Malachite green	0.2 ppm	12 h
Gas bubble disease (GBD)	Water degassing via a splashing cascade system or low-pressure aeration		
Immunostimulation	Vitamin C, intramuscularly	2.5 mg/kg/d	5 d

## 12.5 USE OF ANTIBIOTICS

The use of antibiotics is recommended only in the case of the occurrence of bacterial disease in fish from broodstock. The application of such drugs is not recommended for use in fingerlings intended for release into natural waters. The antibiotics should be administered along with recovery therapy using probiotic preparations on the basis of bacteria, e.g. subculture of *Bacillus subtilis* and *B. licheniformis* – 100 doses per kg for 5–10 d (1 dose = 700 billion spores), *Bifidobacterium globosum* – 1 dose per kg for 10 d (1 dose = 1 million bacterial cells), etc. (Burlachenko and Bychkova, 2005). Specially formulated feeds containing bacterial preparation are used for recovery therapy. The duration of the cycle should be not less than a fortnight. In addition, to reach higher immune

status, it is reasonable to include a complex of liposoluble vitamins AD3E (150 mg/kg for 5 d) and vitamin C (1 g per kg feed for 7–10 d) to mitigate the consequences of stress. In addition to annual health monitoring, a complex of measures should be performed in accordance with FAO better practices (Arthur, Bondad-Reantaso and Subasinghe, 2008).

Commonly used aquaculture sanitation and treatment methods and techniques may be applied in sturgeon culture (Kazarnikova and Shestakovskaya, 2005; FAO, 2007). In summary, only a brief treatment of sturgeon health aspects is given in this chapter, only the most important issues being considered in a more detailed way. In addition, some novel methods of early ultrasonic noninvasive diagnostic methods for some abnormalities of the reproductive system that are being developed by the authors are considered elsewhere in the manual (see Chapter 14).

---

## Chapter 13

### Tagging

#### 13.1 TAGGING REQUIREMENTS

The tags may be divided into several types depending on their application, fish species and size:

- internal tags: PIT tags, coded wire tags (CWT), magnetic tags, chemical substances (oxytetracycline), subcutaneously injected organic colorants and latexes;
- external tags: ear tags for cattle (Figure 126A), clips (Figure 126B), anchor tags (e.g. T- anchor tag, T-bar tag, dink-anchor tag, dart tag);
- marking by liquid colourants (i.e. neon colorant) or tattoos (branding) (Figure 126C);
- marking by partial clipping of fins and scutes.

Fish tagging is an indispensable element of all production processes, including laying-in of spawners; selection of fish for spawning campaigns; breeding work for replacement and broodstock; determination of viability, optimum size and age of released fry; marking for places of release; etc.

In each of the cases, the marking equipment and method of mark introduction have to meet the following requirements:

- minimum influence on the hydrodynamic properties and survival ability of the fish;
- retention of marks during the necessary period of time (in some cases throughout the entire life);
- high speed of marking;
- ease of finding marks on fish, including under field conditions;
- opportunity to transmit the maximum volume of necessary information;
- opportunity to repeatedly read out information from the marks without destruction of fish; and
- lowest possible cost of marks and equipment for their attachment and detection.

**Figure 126:** Tags used for sturgeon: **A** – cattle tag; **B** – clip; **C** – brand made by use of liquid nitrogen.

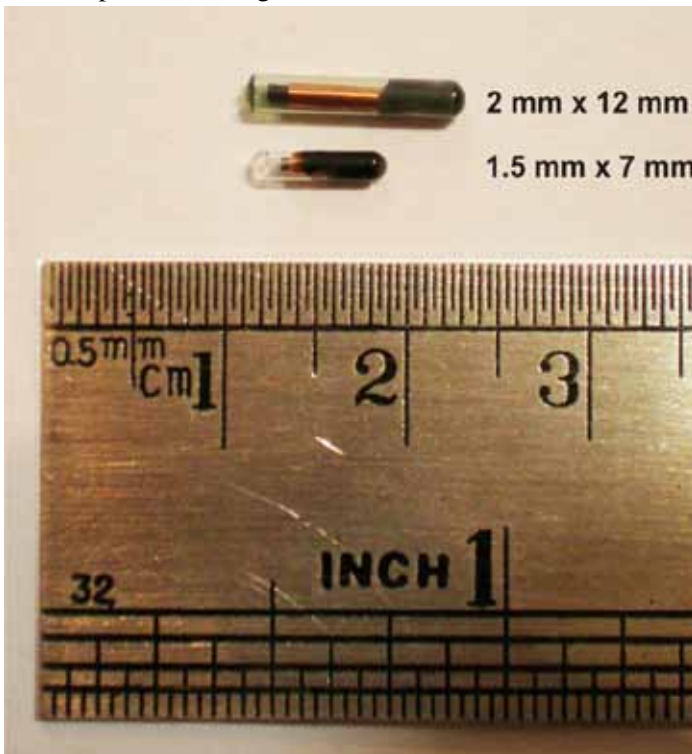


Depending on the purpose of tagging, individual or group marks are used. Among those listed above, at the present time the most advanced tags are the systems of marking with individual PIT tags (for spawners) and CWT tags (for fry).

### 13.2 TAGGING WITH PIT TAGS

PIT-tags are passive integral transponders. They are supplied with an electronic circuit placed on a microprocessor chip. The PIT tags lack a feed element and thus transmit their identified code only when excited by a detector. The sizes of the tags vary from 8x1.2 to 12.2x2.1 mm depending on the manufacturer (Figure 127).

**Figure 127:** Examples of PIT tags.



The tags are enclosed within a glass capsule and exert no effect on the fish after implantation. Their service life is unlimited, and their repeated use is possible after extraction and secondary implantation. The PIT tags are implanted into the subclavicular region (under a pectoral fin or under the first dorsal scute) through the use of a syringe-injector (Figure 128). Reading out information is accomplished remotely with the use of a portable hand-held detector (Figure 129).

**Figure 128:** Marking with a PIT tag.



**Figure 129:** Portable hand-held detector for reading PIT tags.



In addition to the tagging techniques described above, it is efficient to place temporary tags on the caudal peduncle while handling spawners in the period of preparation after hormonal injection and while running spawning campaigns (Conte et al., 1988). In some cases, for easier identification of specimens tagged by PIT-tags, it is expedient to also mark them with visible tags. Visible implant elastometer (VIE) tags are implanted on the underside of the rostrum by using different colours and orientation to body axis ([www.nmt-inc.com](http://www.nmt-inc.com)). These tags are injected as a liquid that soon cures to a pliable solid.

### 13.3 TAGGING WITH CWT TAGS

For large-scale tagging of fry, the best results are provided by the use of micro-decimal CWT tags (stainless steel, 1.067 mm in length and 0.254 mm in diameter – see [www.nmt.us](http://www.nmt.us)), which are introduced into the area of alar cartilage or beneath the first back scute with the use of a special injector (Figure 130). Each tag bears on its surface one of the group of binary codes. To tag small fry (less than 2 g), shortened tags (0.5 mm in length and of standard diameter) are available.

**Figure 130:** The procedure of fry marking with CWT tags.



The tags are magnetized on implantation and remain magnetic, typically during the entire life of the fish, permitting their detection at any time by the special detectors (Figure 131).



**Figure 131:** Detection of a coded wire micro-tag with the use of a special detector.



#### **13.4 A FRAMEWORK FOR DEVELOPING AN INTERNATIONAL PROGRAMME OF TAGGING HATCHERY-PRODUCED STURGEON JUVENILES**

A framework for development of an international programme of tagging hatchery-produced sturgeon juveniles can be based on worldwide experience (see <http://www.nmt-inc.com/> and <http://www.hafro.is/catag>) that shows that an effectively coordinated programme can yield much more reliable information than can a series of uncoordinated programmes. The information that could be obtained from a coordinated international effort includes the following:

- distribution and dispersion of fish stocked from each hatchery throughout the sea basin;
- growth rates of different groups of stocked fish;
- survival of stocked fish; and
- differential performance (i.e. survival, growth, contribution to fisheries) of different treatment groups, based on, for example, time of release, size at release, location of release and genetic origin.

The use of a secondary mark is strongly recommended; this mark should be applied to all CWT juveniles and to no other fish. The nature of this secondary mark warrants careful consideration. Clipping of a specific barbel (for example, extreme right) could be effective for recaptures during the first year or two, but regrowth may make this method ineffective as a long-term mark. It has been established that barbel clipping has little or no adverse effect upon the health



and well-being of the fish. Clipping of one of the pelvic fins would create a longer-term mark, but there is concern that this may have some adverse impact (this would need to be explored before such a mark is adopted for large-scale deployment). Other marks, such as clipping of other barbels or fins, could be used freely for other purposes. Such marks would not indicate a CWT, although there is no reason that CWT fish could not bear such a mark in addition to the CWT-specific secondary mark.

Thus the main components of a CWT International Programme are:

- tagging and standardized release;
- tag recovery;
- centralized database management and data analysis;
- free data access for download over the Internet; and
- adaptive management and international coordination.

---

## Chapter 14

### Early sexing and staging maturity in live sturgeons by using ultrasound techniques

#### 14.1 EQUIPMENT FOR ULTRASOUND DIAGNOSTICS OF SEX AND GONAD MATURITY STATUS IN LIVE STURGEONS

Ultrasound scanning systems have been widely applied in human medicine. More recently, ultrasound imaging has attracted increasing interest for the study of the internal anatomy of fish. The noninvasiveness of this technique, as well as the possibility of viewing dynamic images (cine mode), combined with its reliability, has made ultrasound scanning systems a promising research tool in fisheries (Mattson, 1991; Karlsen and Hol 1994; Goddard, 1995; Palmer, *et al.*, 1995). Some relevant advantages include the technique's:

- *Biological safety*: Despite the fact that ultrasound of high frequency can affect the viability of animal cells and damage DNA *in vitro*, it has been established that ultrasound of diagnostic intensities is biologically safe and does not cause any clinical impacts (i.e. due to short-term exposure to the pulse waves used in the ultrasonography).
- *Express efficiency*: The properly arranged ultrasound diagnostics procedure is short (up to 10 s). However, to exclude some rare or complicated cases like hermaphroditism and abnormalities of the reproductive system (extension of connective tissue into the generative part of the gonad, tumors and cysts) requires extra time.
- *Noninvasiveness*: In the course of the examination, organs and tissues are not destroyed, hence the influence of stressors is minimal.

##### 14.1.1 Characteristics of ultrasound waves

Ultrasound is of wave nature and possesses physical wave characteristics such as frequency, length, velocity, etc. While studying the peculiarities of ultrasound wave transmission in the body of sturgeons, the main media can be singled out: bones (including scutes), cartilage, soft tissues and gas. These media have different acoustic resistance (Table 69) and enhancement and exhibit different reflection of ultrasound beams (echogenicity).

**Table 69:** Velocity of sound wave propagation ( $V$ ), density ( $\rho$ ) and resistance ( $Z=\rho V$ ) of different substances (Palmer *et al.*, 1995).

Substance	$V$ , m/s	$\rho$ , g/cm <sup>3</sup>	$Z$
air	330	0.0012	$41.3 \times 10^{-5}$
tissues:	1 476–1 570	0.928–1.055	1.37–1.66
adipose tissue	$\approx 1\ 450$		
muscle	$\approx 1\ 540$		
liver	$\approx 1\ 540$		
water	$\approx 1\ 482$		
bone	3 360–4 000	1.85	6.2
cartilage	2 800–3 200	1.65	$4.9 \times 10^3$

### 14.1.2 Transducers

An ultrasound scanner for sturgeon examination is generally equipped with a linear array 5–10 MHz/40–60 mm transducer, providing ultrasound images of high resolution for fish of weight ranging from 0.5 kg (sterlet) to 50 kg (giant sturgeon), with a peak efficiency for fish (of all species) in the weight range of 2–20 kg. Moreover, a standard linear transducer (Figure 132) provides a low depth of scanning due to a rather high sound frequency. Therefore, for large specimens (>50 kg), it is recommended to use a convex transducer (Figure 132), allowing 2.0–3.5 Mhz and >20 cm depth operation. Unfortunately, transducers of this type produce a low resolution (Chebanov and Galich, 2008).

To ensure distinct visualization of fish gonads, the minimum linear size of gonad in histological sections should be at least 10–20 times larger than the ultrasound wave length. Otherwise, the margins of the organs will be indistinct or even invisible. When a 5–10 Mhz transducer is used, the minimum size of the structure should not be less than 2 mm. A 3–5 Mhz transducer has a focus depth range of 7–9 cm, while 5, 7.5 and 10 Mhz transducers have focus depth ranges of 5–7, 4–5 and 3–4 cm, respectively. Progressive attenuation of the sound in the course of tissue penetration depends on the type of tissue and its density and rate of heterogeneity.

The wave reflection propagates in the direction of the sound source. Therefore in order to obtain a distinct image, the ultrasound beam should be directed to the gonad (or other experimental organ) at a 90° angle, thus ensuring maximum reflection and further visualization.

In some complicated cases and in the course of research, when target echograms should be of high resolution (especially while studying smaller fish), expensive linear transducers of higher frequency range (up to 25 Mhz) may be used, for example, “Esaote”, with a frequency of 12.5 Mhz (Bonput, 2006).

### ***14.1.2.1 Convex transducer***

The section has a form that is intermediate between the shape of linear and selective transducer sections. A transducer of this kind (Figure 132A) is typically included in standard sets of ultrasound systems. It has a semicircular surface and cannot be tightly applied to the experimental part of the fish. In addition, convex transducers, as a rule, have low frequency and hence, relatively low resolution capacity but high depth of ultrasound penetration (scanning). Thus it is wise to use this type only in the case of large fish.

**Figure 132:** Ultrasound transducers: **A** – convex; **B** – linear.



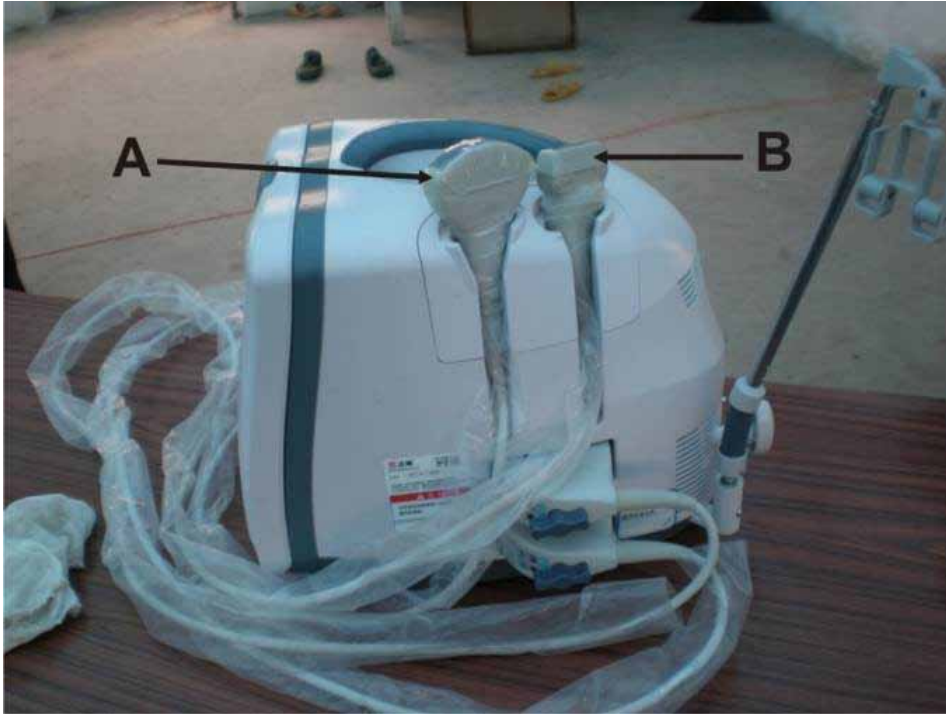
### ***14.1.2.2 Linear transducer***

Sections obtained using such transducers (Figure 132) are rectangular in shape. The scanning plane of the transducer is flat, can be tightly applied to surfaces and has proved to be the best choice for examination of organs and tissues in sturgeons.

## **14.1.3 Mobile data and analytical system based on the Mindray DP-6600 ultrasound scanner**

Recommended for wider application in sturgeon culture, the portable ultrasound scanner Mindray DP-6600 ([www.mindray.com](http://www.mindray.com), P.R. China) has proved to be a better choice than the “My Sono-201” system described by Chebanov, Galich and Chmyr (2004), both in terms of its price and resolution capacity of a 10-inch monitor with option of progressive line scanning (Figure 133).

**Figure 133:** Ultrasound portable scanning system Mindray DP-6600: **A** – convex transducer; **B**– linear transducer.

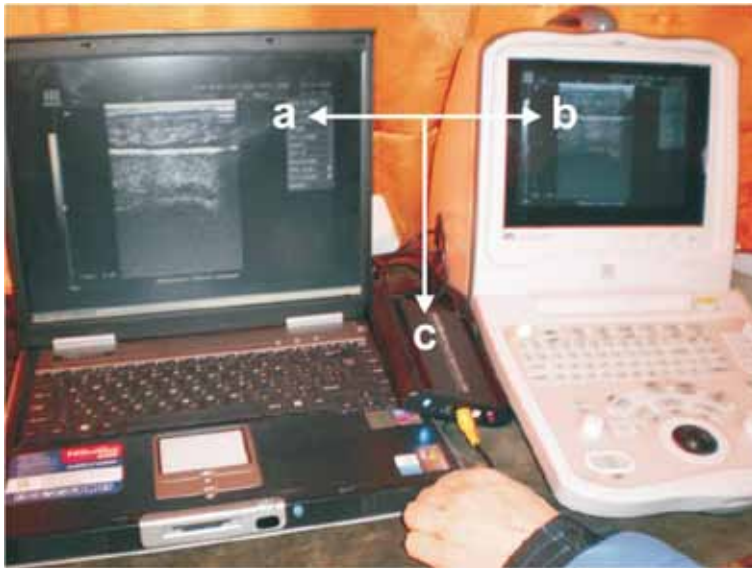


The main features of the Mindray DP-6600 system are as follows:

- transducer connectors for two transducers: convex (frequency range 2–3.5 MHz) and linear (5–10 MHz);
- depth of scanning from 25.9 to 246 mm (depending on transducer);
- 115 image memory;
- video output;
- 2 USB ports; and
- software for measurements and calculations.

The features of this ultrasound system enable the recording of scanning procedure (the system is to be connected to a personal computer (PC) via video output) for successive analysis and training of specialists, as well as the making of static frames. The storage of information is enabled both in the flash memory of the scanner and in an external USB storage carrier. This feature is very useful and allows the considerably enhanced operating efficiency of this scanning system. The scanning system in combination with a PC has proved to be an effective echogram processing complex (Figure 134).

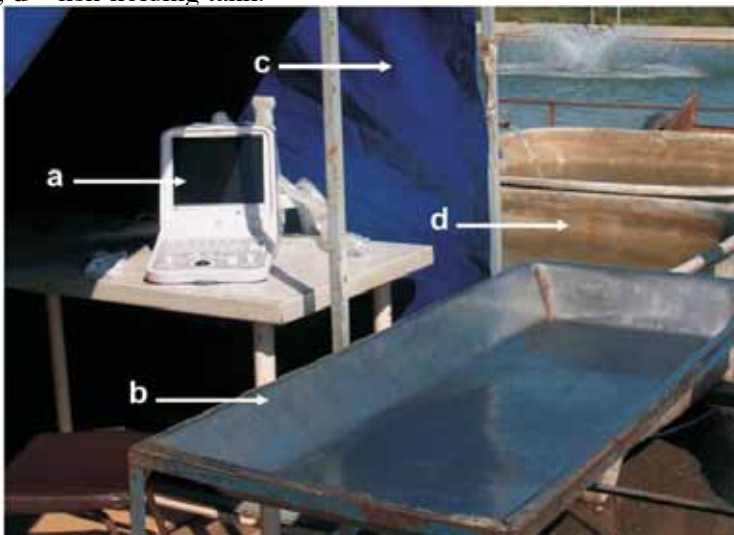
**Figure 134:** Mobile data and analytical system on the basis of the ultrasound scanner Mindray DP-6600: **A** – notebook; **B** – ultrasound scanning system; **C** – MPEG2-Encoder.



#### 14.1.4 Work place organization

The early live identification of sex and stages of gonadal development requires the special organization of the work station (operator's place) (Figure 135).

**Figure 135:** Equipment of the mobile data and analytical system on the basis of the ultrasound scanner Mindray DP-6600: **a** – ultrasound scanner; **b** – special stainless steel table for fish; **c** – tent to protect the scanner monitor from direct sunlight; **d** – fish-holding tank.



The work place should include:

- a table for ultrasound equipment that is large enough to enable the operator to conduct video examination and prepare written records;
- a customized (metal or wood) table with high sides for fish holding (persons who handle fish should have free access to the fish table);
- moderate illumination so as not to obstruct reading of the video information on the monitor (the operator performs scanning in a sitting position and at the same time watches the video image on the LCD monitor); and
- fish-holding tanks that are located in close proximity to the ultrasound complex).

All the equipment should be installed, connected and adjusted prior to beginning the sampling procedure. The fish is placed on its right side on the customized table, with either the ventral (head to the left) or dorsal (head to the right) side towards the operator. The fish should be held in the same position throughout the process of scanning, which can take from a few seconds to a few minutes.

#### **14.2 USE OF SONOGRAPHY FOR EARLY DETERMINATION OF SEX AND GONAD MATURITY STAGE**

The ability to identify an image and to determine sex and stage of maturity will depend (if the recommendations for equipment parameters are followed) on the following factors: species, age, size, conditions and mode of rearing.

The diagnostic markers for determination of sex are:

- localization of the generative tissue in the gonad (i.e. medial, lateral, etc);
- presence or absence of the gonadal tunic (membrane);
- character of the surface and margins of the gonad (i.e. unbroken or broken margin, straight or curved margin);
- echogenicity of the generative tissue, as revealed by different brightness on the screen image;
- homogeneity or heterogeneity of the structure of gonad tissues; and
- structure of the caudal margin of the gonad and its relative distance from the genital opening.

It should be noted that during overripening and resorbing of eggs and testes, the echogenicity of the tissues is changing. Hyperechoic testicular tissue becomes anechoic or hypoechoic, while anechogenic ovarian tissue becomes hypoechoic.

Table 55 shows weight and age requirements appropriate for the live sex express identification using ultrasound. The period that follows overwintering (temperature range from 8 to 12 °C) is the best time for conducting early noninvasive sex determination at sturgeon hatcheries with natural conditions and for warmwater hatcheries after two months holding at minimum water temperatures. Before sampling, the fish should be deprived of feed for 12 days (minimum). The less appropriate season for sex identification is a period of intensive feeding when the temperatures are higher than 18 °C. Regardless of the higher growth rates, the detection of sex in fish reared at industrial hatcheries

is a difficult task due to their considerable fat accumulation and somatic growth prevailing over the growth of germinal tissue.

### 14.3 ULTRASOUND GLOSSARY

Acoustic beam (ray)	A cluster of ultrasound waves produced by a transducer
Acoustic resistance	Resistance of tissues to particle oscillation induced by ultrasound waves. Visualization of different scanning objects is possible due to acoustic resistance.
Anechogenous structures	Objects that completely conduct sound (thus giving no reflections). They are seen on the screen as foci of black colour (e.g. liquids).
Attenuation	The decrease in intensity of ultrasonic waves on their passing through tissues.
Boundary	The line dividing two types of tissue differently conducting ultrasound, defined as a region of reflection on the separation boundary.
Echogenicity	The ability of a tissue (or organ) to reflect an ultrasound ray.
Echostructures	The structures of a tissue or organ obtained upon ultrasound representation.
Frequency	Number of full ultrasonic waves in 1 s, expressed in MHz.
Frontal section	A section that passes lengthwise of the long axis of the body from one lateral part of the body to another, dividing it into dorsal and ventral parts.
Heterogeneous echostructures	Objects that are characterized by non-uniformity in the propagation of the echosignal in organs having mixed echogenicity.
Homogeneous echostructures	Objects that are characterized by a uniform distribution of echosignal of the same intensity across the organ.
Hyperechogenous structures	Objects of high reflecting capacity that reflect the larger part of ultrasound rays (e.g. bone, gas, collagen) and which are seen on the screen as bright-white structures.
Hypoechogenous structures	Objects that both partially pass and reflect ultrasound (e.g. soft tissues) and which are seen on the screen as dark-grey spots.
Reflection	The change in direction of ultrasonic waves front at an interface between two different media; so that an ultrasonic ray returns into the media of its origin.
Sensitivity	Amplification of reflected ultrasound waves by the ultrasound system. Reflected signals from deeper tissues require more intensive amplification than those closer to the surface.
Scanning plane	Section of organs and tissues through which an ultrasound ray passes.
Transducer (probe)	A part of the ultrasound system that directly adjoins the tested object. It transforms electrical energy into ultrasound waves and also detects reflected waves and translates them into electrical energy.
Transverse section	A section passing at right angles to the longitudinal axis of the body, dividing it into cranial and caudal parts.



## 14.4 ANATOMICAL STRUCTURE AND NONINVASIVE DETECTION OF INNER ORGANS AND TISSUES IN STURGEONS BY ULTRASOUND TECHNIQUE

### 14.4.1 Anatomical structure of inner organs

The successful implementation of ultrasound diagnostics requires a clear understanding of the peculiarities of sturgeon anatomy (Gurtovoy, Matveev and Dzerjinskiy, 1976). A detailed description of sturgeon anatomy is beyond the scope of this manual; however, relevant aspects are discussed briefly below.

#### 14.4.1.1 Reproductive system

The *ovaries* (singular: *ovary*) are the female gonads, which are located on the lateral side of the body cavity and connected with the dorsal wall of the body by mesovaria. They are composed of ovules of different generation located on the ovigerous lamellae.

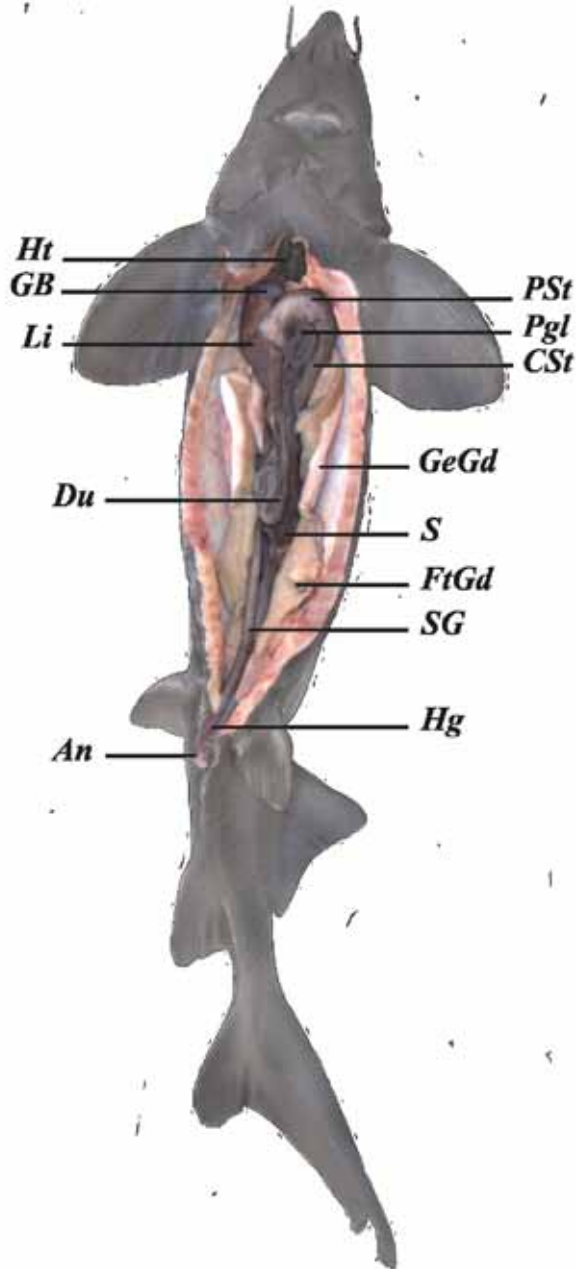
The *testes* (singular: *testis*) are located to the right and the left of the digestive system and as distinct from the ovaries, are covered by a connective tissue tunic and have a lobulose structure. The oviduct funnels are connected with the genital ducts and are located at the lateral sides in males and females. (Figure 136).

#### 14.4.1.2 Excretory system

The *kidneys are* located along the intermediate intestine and the colon. They are transpierced by blood vessels and covered by a membrane.

The *renal ducts* function as ureters and spermaducts (*vas deferens*). The ureters begin at the external side of the anterior part of the kidney as single renal tubules forming the common duct with the oviduct funnel.

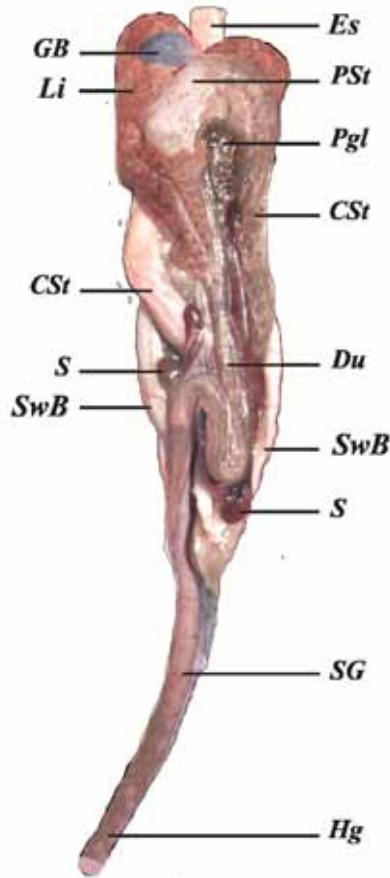
**Figure 136:** Structure of inner organs of Siberian sturgeon. **Key:** Ht – heart; GB – gall bladder; Li – liver; PSt – pyloric stomach; PGI – pyloric gland; CSt – cardiac stomach; Du – duodenum; S – spleen; GeGd – generative part of the gonad; FtGd – fat part of the gonad; SG – spiral gut; Hg – hind gut; An –anus.



### 14.4.1.3 Digestive system

The digestive system of sturgeons appears to be intermediate between that of cartilaginous and bony fishes (Figure 137). The peculiarities of the digestive system that increase the internal absorption surface area of the digestive epithelium are the set of loops formed by the intestine (as in bony fishes) and the preservation of the spiral valve in the midgut area, which is typical of cartilaginous fishes (Gurtovoy, Matveev and Dzerjinskiy, 1976).

**Figure 137:** Structure of the inner organs of Russian sturgeon. **Key:** Es – oesophagus; Li – liver; GB – gall bladder; PSt – pyloric stomach; Pgl – pyloric gland; CSt – cardiac stomach; SwB – swimbladder; Du – duodenum; S – spleen; SG – spiral gut; Hg – hind gut; An – anal opening.



The **liver** is a gland of irregular shape divided into two separate lobes, left and right. The oval **gall bladder** is located in the posterior part of the liver and connects to the **duodenum** via the bile duct.

The short **pharynx** is connected with the oesophagus, which passes to the cardiac part of the stomach. The oesophageal musculature is comprised of two layers, an inner longitudinal layer and an outer circular one.

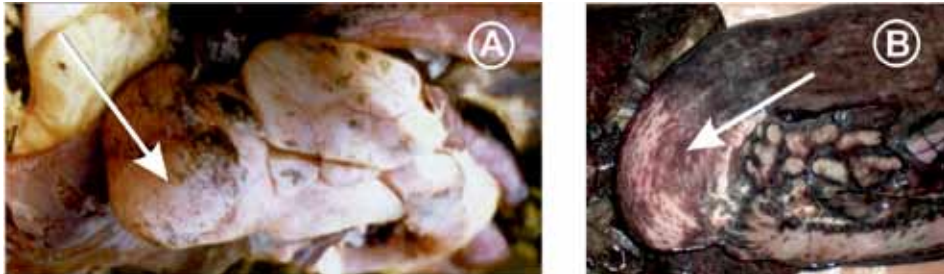
The *stomach* is covered by the liver, so that only its posterior part is visible. It consists of the cardiac and pyloric sections. The *swimbladder duct* enters the cavity of the cardiac part of the stomach from the dorsal side.

The *pyloric region of the stomach* is connected with the intestine via the *pyloric valve*, which regulates the intercommunication with the front section of the midgut (the duodenum), which has a specific porous mucous membrane and is separated from the spiral gut by a circular fold (valve).

*Pyloric adnexa* are embedded in connective tissue, surrounded by a serous membrane and form one compact formation of bean-like shape, the *pyloric gland*, linked with the mid part of the intestine.

An analysis of the structure of the alimentary system in all sturgeon species (Artyukhin, 2008) showed that the stomach of major benthic-feeding *Acipenser* species has a bulbous dilation (chamber) intended for the crushing of mollusc shells. The sea species of *Acipenser* (i.e. *A. sturio*, *A. oxyrinchus*, *A. medirostris*, *A. transmontanus* and *A. sinensis*) have lost this feature in the course of transition to predation and have an intestinal structure similar to predators of the genus *Huso* (i.e. beluga (Figure 138) and kaluga) (Artyukhin, 1995).

**Figure 138:** Dissected views of the stomach: **A** – view of stomach in Persian sturgeon (Artyukhin, 2008); **B** – view of stomach of domesticated form of beluga – “bulbous” dilation (arrows) is not expressed (domestic broodstock of the South Branch Federal Center of Selection and Genetics for Aquaculture, Krasnodar, Russia).



The *pancreatic gland (pancreas)* is located along the right side of the duodenum, partially turning to the right side. Its front end is in close contact with the lappets of the *liver* and the additional lobe of the *lien*. The single lappets of the pancreatic gland can be seen in large sturgeon individuals: one located along the outer wall of the duodenum, another linked with the central part of the liver along the inner edge of the gland.

The *duodenum* begins near the pyloric gland, passes down to the middle of the body, then turns upward, making a loop to the lower border of the right lobe of the liver or to the pyloric gland and then turning again left downwards, connecting to the spiral intestine.

The *colon* is a part of the intestine having thick muscular walls. It is formed by entodermal canal convolution with a curled fold of mucous membrane inside. The number of turns of the spiral fold ranges from 5 to 10 depending on the species of sturgeon. The smaller folds, which are linked with the smooth walls of the hindgut are located on the inner walls of the intestine beside the large folds.

The *hindgut* (rectum) is characterized by a considerably developed circular muscular layer ending with the anal opening.

The *anal opening* (anus) is the most anterior of four openings (the anal opening, two small abdominal pores (located on the sides) and the posterior genital opening) and is located behind the ventral fins.

#### 14.4.1.4 Other inner organs

The *swimbladder*, which occupies all of the dorsal area of the abdominal cavity, is a hollow sac that inosculates densely with the peritoneum by an upper wall. The swimbladder in all sturgeons is connected with the digestive tract by a channel.

The *lien* is a glandular organ of V-like shape surrounding the duodenal loop from the left and from the right and underlaying it. The lien consists of the main and supplementary lobes. The supplementary lobe is directly adjacent to the liver and the pancreatic gland.

### 14.5 NONINVASIVE DETECTION OF ORGANS AND TISSUES BY ULTRASOUND TECHNIQUE

#### 14.5.1 Scanning procedure schedule

Noninvasive ultrasound express examination is conducted in the frontal and transverse planes. During examination the transducer is pressed against the body in the region of the 3<sup>rd</sup>–4<sup>th</sup> ventral scutes (counting from the pelvic fins), so that one edge of the transducer is located above the scutes (Figure 139).

**Figure 139:** Correct positioning of the transducer in the process of frontal scanning. The transducer is moving from the tail towards the head and backwards.



The optimal transverse section is found by bending the transducer (Figure 140). Then the transducer is slowly moved in the chosen plane towards the head. The examination is then conducted along the entire length of the gonad.

**Figure 140:** Correct positioning of the transducer at scanning in transverse plane.



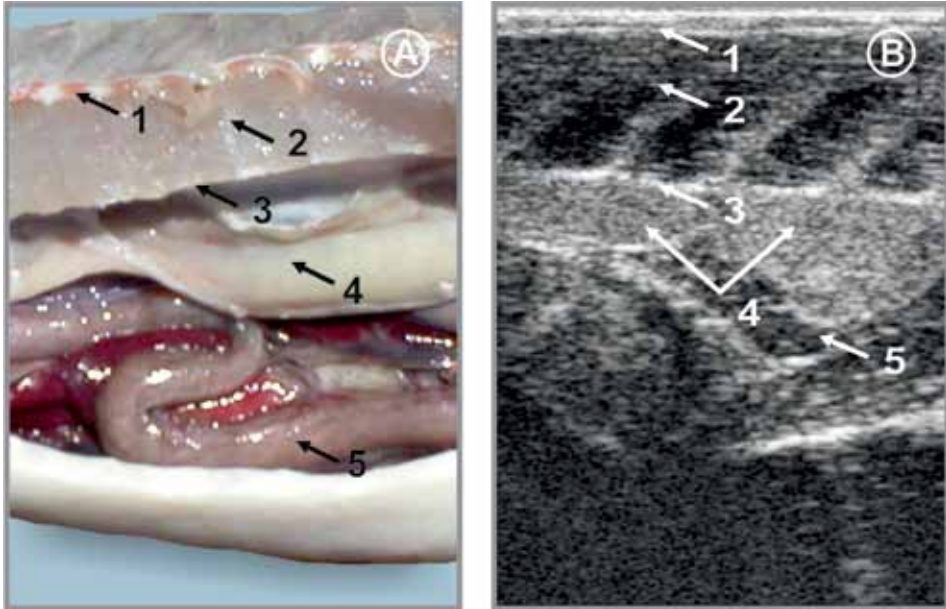
#### 14.5.2 Peculiarities of organ visualization at frontal ultrasound scanning

The following tissues and organs are visible on the frontal scanning plane (from the scanning plane of the transducer) (Figure 141):

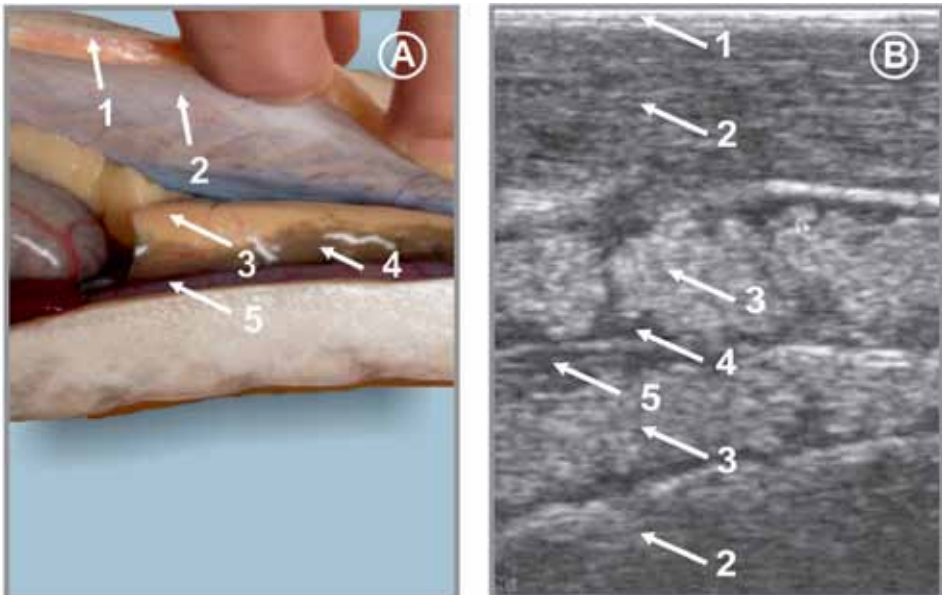
1. skin – as a thin hyperechoic region, and subcutaneous fat tissue, as a narrow (2–3 mm) strip with moderate echogenicity;
2. muscle tissue – the broad region of mixed echogenicity. The muscle fiber is a region of average brightness (covered horizontally by mixed echogenicity) alternating with muscle walls separated by a connective tissue (appearing on the screen as narrow inclined, almost vertical strips, brighter than muscles);
3. serous membrane of the abdominal cavity – appearing as a bright, smooth and distinct boundary line;
4. gonad – different screen images for males and females are associated with the echostructure of the gonad:
  - Ggonad can be covered by a tunic (in males) and have a structure of complex echogenicity: hyperechoic, hypoechoic, anaechoic or of mixed echogenicity (for more details refer to Chapter 4);
  - the male gonad is an echo-homogeneous structure surrounded by a bright hyperechoic membrane that is visualized along the gonad;
  - the female gonad is echo-heterogeneous without clear boundaries; at dynamic examination, it appears as an overlapping “cloudy” structure;
5. Bintestine – is in the form of a longitudinal, tubular structure with clear enclosures and consisting of two layers, an external hypoechoic layer and an internal, hyperechoic layer. Gas in the intestine is visualized as hyperechoic structures of irregular shape and casts an acoustic shadow on the lower-located organs (for more details refer to Figure 152 in Section 14.6.1.4).



**Figure 141:** View of organs and tissues location in the body cavity of Russian sturgeon male: **A** – dissected view; **B** – frontal ultrasound image (1 – skin and subcutaneous tissue; 2 – muscle fiber; 3 – serous membrane; 4 – gonad; 5 – colon).



**Figure 142:** View of organs location in the body cavity of Russian sturgeon female: **A** – dissected view; **B** – frontal ultrasound image (1 – skin and subcutaneous tissue; 2 – muscle fiber; 3 – gonad; 4 – fat; 5 – colon).

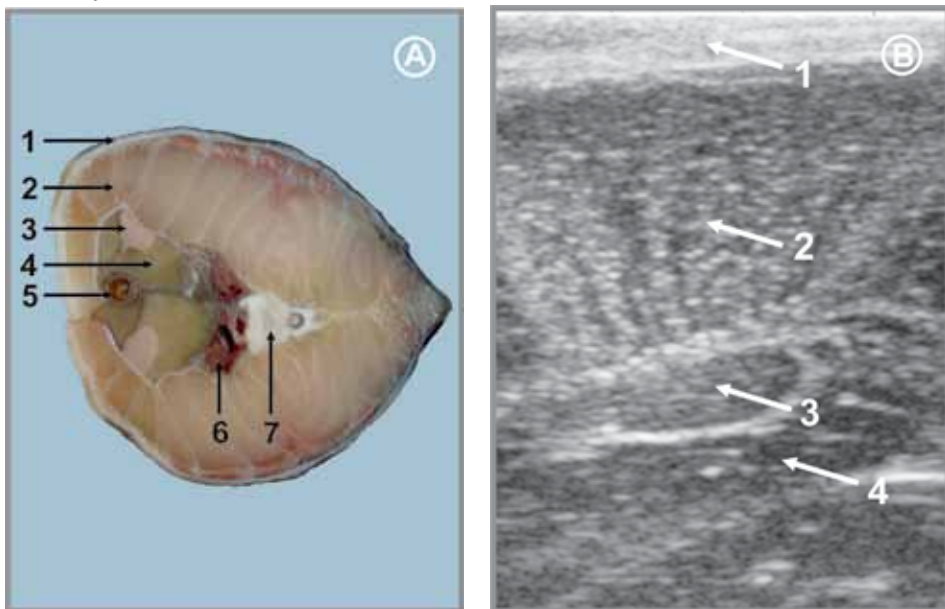


In fish of small size (less than 4 kg), a second gonad and even muscles and skin (from the other side) are visible under the gonad in reverse order (Figure 142).

### 14.5.3 Peculiarities of organ visualization at transverse ultrasound scanning

The localization of organs on the screen of the monitor is different at transverse scanning as compared to frontal scanning (Figure 143).

**Figure 143:** View of organ location in the body cavity of the male Siberian sturgeon: **A** – dissected transverse view; **B** – transverse ultrasound image (**1** – skin and subcutaneous tissue; **2** – muscle fiber; **3** – gonad; **4** – fat; **5** – colon; **6** – kidneys; **7** – notochord).



The skin, adipose layer, muscular tissue, serous tunic and abdominal cavity are visualized in the same way as at frontal scanning.

The testicular tissue has an oval and almond-like shape enclosed within a clear hyperechoic borderline with internal echo-uniform structure and is positioned (in contrast to ovarian tissue) immediately under the muscular tissue. At the stage II of gonad maturity, the generative part is partially (II, II-semifatty, II–III) or completely (II fatty) surrounded by fat tissue, which appears on the screen of the monitor as a hypoechoic (dark, almost black) zone. The ovarian tissue (region of mixed echogenicity) does not adjoin the muscles, having no distinct margins. At some stages, this part can be separated from the muscular tissue by the hyperechoic fat part (Figure 144).



**Figure 144:** Ultrasound image of transverse section of ovary in Russian sturgeon female: **1** – skin and subcutaneous tissue; **2** – muscle fiber; **3** – ovary; **4** – ovarian fat.



At small size of fish, the intestine, notochord and kidneys are well evident at transverse scanning.

#### **14.6 EARLY SEXING AND STAGING MATURITY OF STURGEONS BY USING NONINVASIVE EXPRESS ULTRASOUND TECHNIQUE**

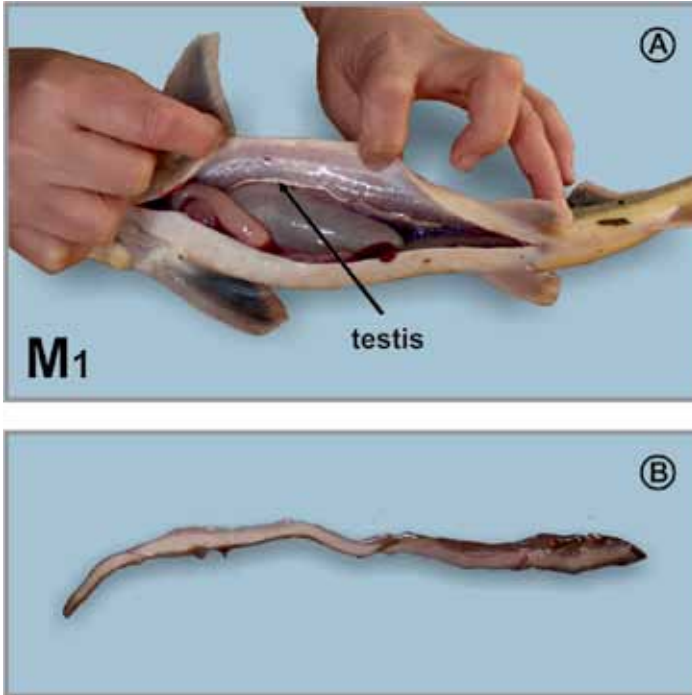
To describe maturity stages for gonads of sturgeon, we have used the maturity scale developed by Trusov (1972) for Russian sturgeon. The peculiarities of the different developmental stages of the testes and ovaries in sturgeons presented below are important for the analysis of ultrasound images of sturgeon gonads.

##### **14.6.1 Peculiarities of different stages of testicular development**

###### ***14.6.1.1 Male maturity stage I (M1)***

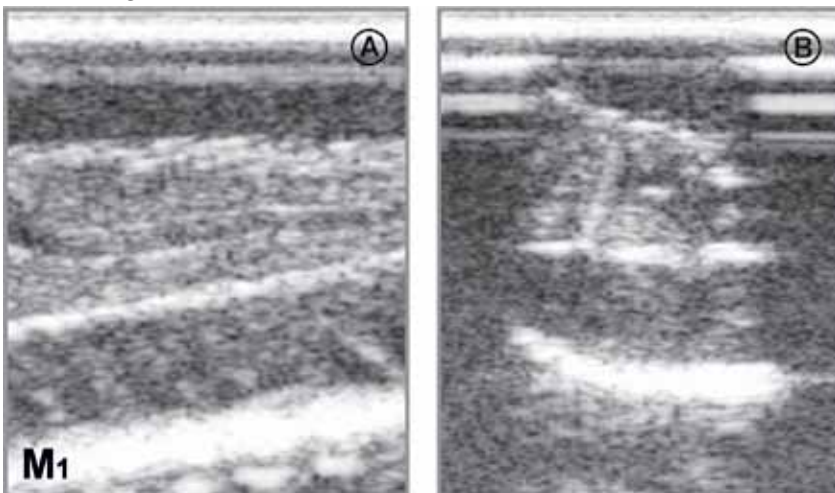
The testes appear as thin strips of white and grey to light pink colour (Figure 145). At the onset of the stage, they are composed primarily of connective tissue, while at stage completion the testis reaches 5–7 mm in width. The fat tissue of the testis is practically not evident, while the testicular tissue has a milky-white colour.

**Figure 145:** Testes at maturity stage I (M1) in male sterlet. Fish: age – 1 year; total length/fork length – 41.0/33.0 cm; weight – 0.25 kg. Testes: length – 8.7/8.7 cm; width – 0.4 cm. **A** – location of testis in the body cavity; **B** – view of testis.



At ultrasound scanning of males (Figure 146), testicular tissue is not visible due to its small size at maturity stage I.

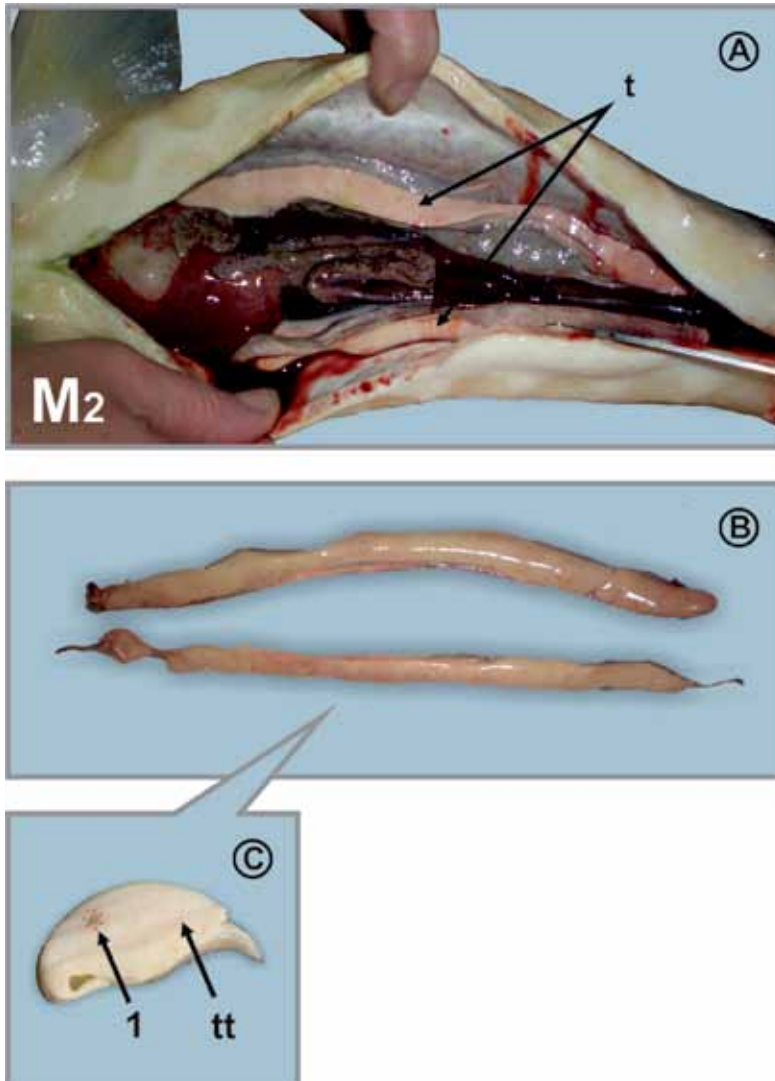
**Figure 146:** Ultrasound images of testes in male sterlet at maturity stage I: **A** – frontal section; **B** – transverse section (image of this specimen's gonads is presented in Figure 145).



#### 14.6.1.2 Male maturity stage II (M2)

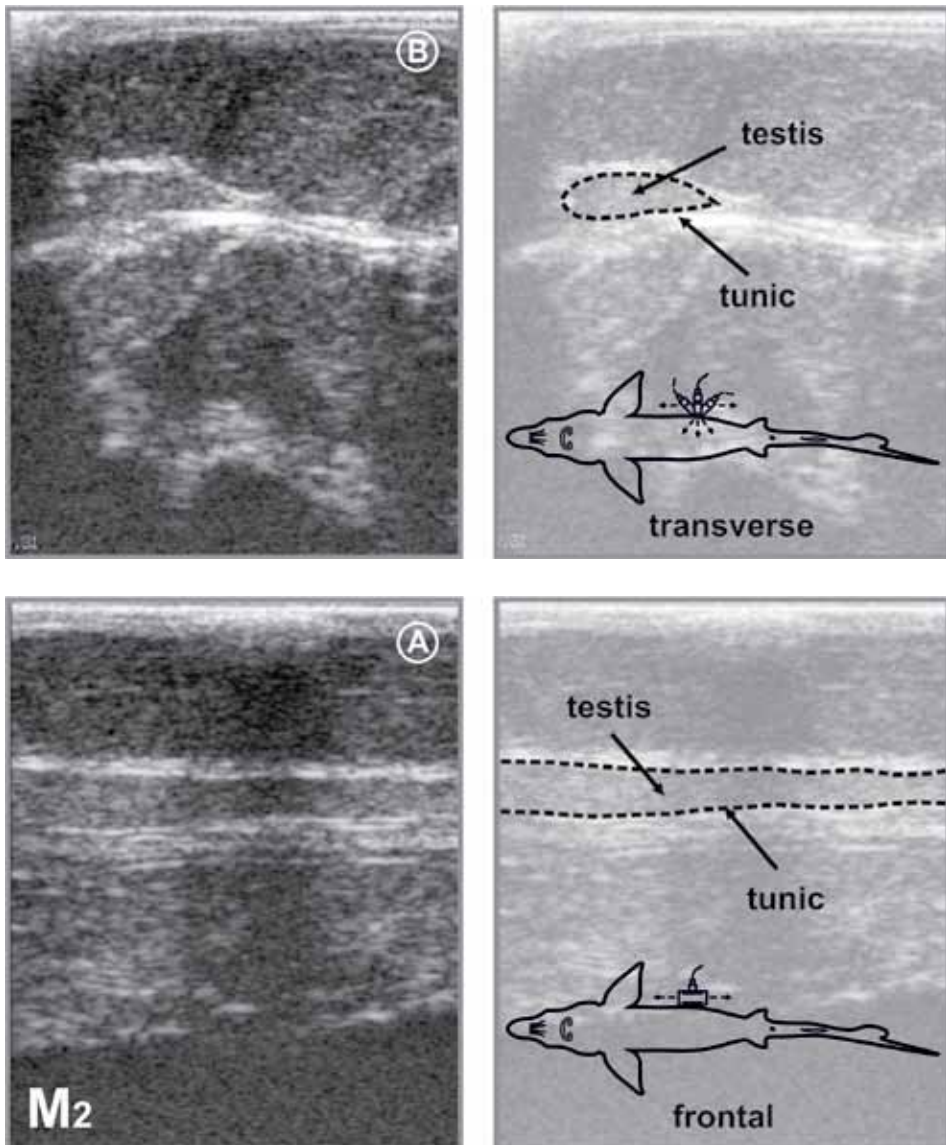
The testes at stage II are well discernable, typically having white or pink-white colour (Figure 147). The width of the testicular tissue in fish at first maturation ranges from 0.3 to 0.6 cm, while in rematuring individuals, it ranges from 1.0 to 1.5 cm. The overall width (with the fat tissue) is 1.5 cm and up to 3.5 cm at first and recurrent maturity, respectively. These differences enable identification of males at recurrent maturity.

**Figure 147:** Testes of Russian sturgeon at maturity stage II (M2). Fish: age – 2 years; total length/fork length – 75.0/65.0 cm; weight – 1.9 kg. Testes: weight – 25.0 (15.0/10.0) g; length – 23.0/20.0 cm; width – 1.5 cm. **A** – localization of gonad in the body cavity (t – testis); **B** – view of testes; **C** – transverse section of testis (1 – blood vessel, tt – testicular tissue).



Starting from maturity stage II, testicular tissue can be easily visible in frontal and transverse sections (Figure 148). The testicular part is hyperechoic and has distinct margins. The fat part is under- or slightly developed from the medial side and practically not visible. The margins of the gonad are smoothly curved, while the bright hyperechoic tunic of the testis is clearly seen.

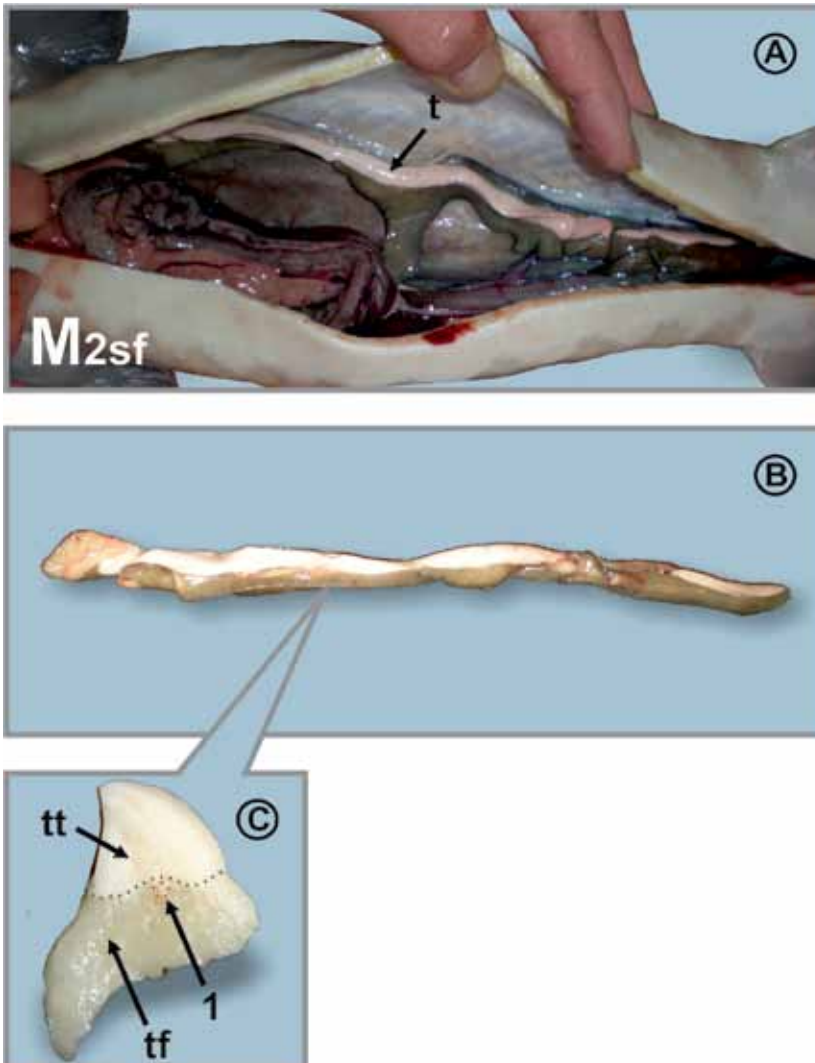
**Figure 148:** Ultrasound images of frontal and transverse sections of testes in Russian sturgeon male at maturity stage II (M<sub>2</sub>) (image of this specimen's gonads is presented on Figure 147).



### 14.6.1.3 Male maturity stage II semi-fatty (M2sf)

Fat accumulation starts from the medial side and gradually spreads to the lateral side (Figure 149). The state when testicular tissue is covered by fat to one half of its width (and can be seen only from the lateral side) is considered as stage II semi-fatty. Its width ranges from 0.2 to 2.5 cm (including 1.0–5.0 cm of fat); the colour varies from pinkish to white.

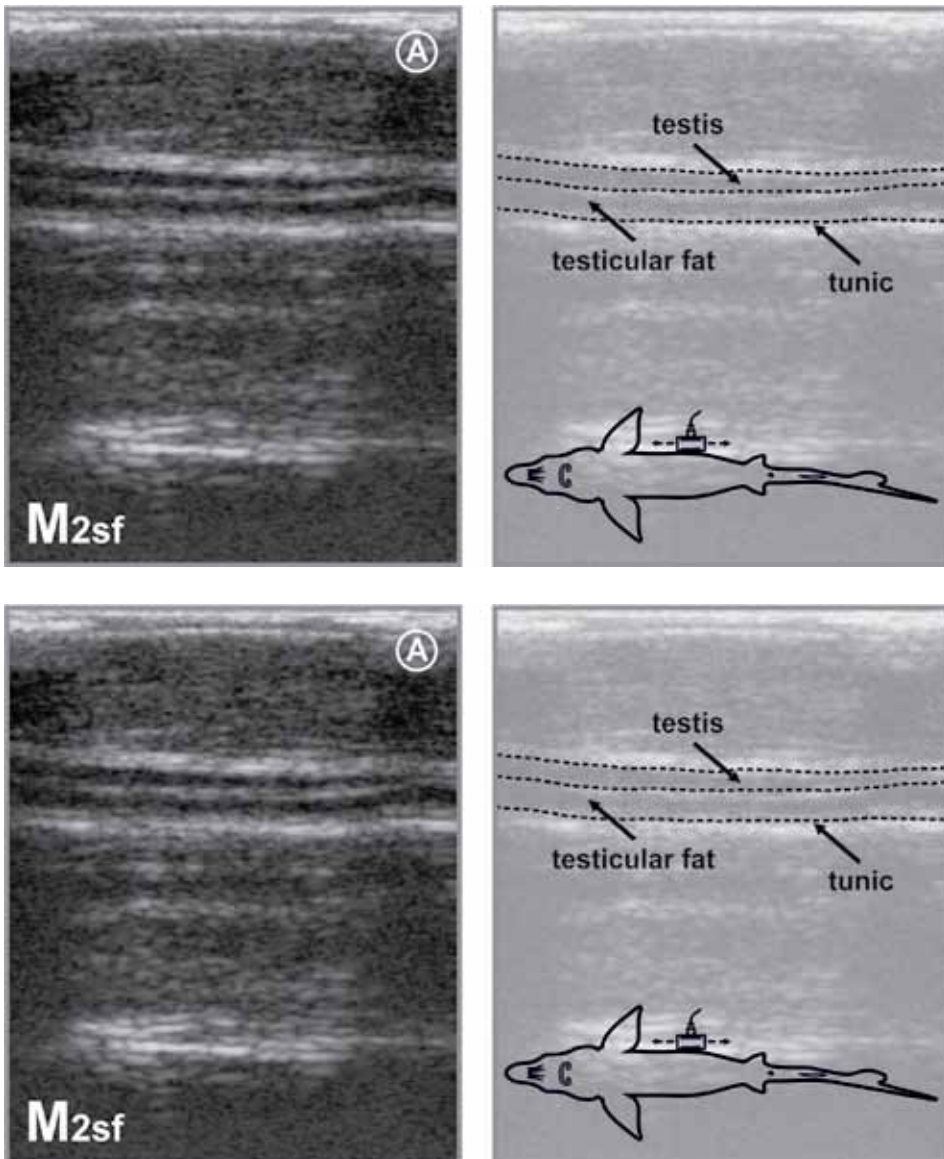
**Figure 149:** Testis of Siberian sturgeon at maturity stage II semi-fatty (M2sf). Fish: age – 2 years; total length/fork length – 78.0/67.0 cm; weight – 2 kg. Testes (t): weight – 20.0 (10.0/10.0) g; length – 28.5/28.5 cm; width – (overall/testicular tissue) 1.3/0.6 cm. **A** – localization of gonad in the body cavity; **B** – view of testis; **C** – transverse section of testis (**1** – blood vessel; t – testis; tf – testis fat; tt – testicular tissue).





At developmental stages II semi-fatty and fat, the testicular tissue exhibits a slight increase. The overall volume of the gonad expands due to fat accumulation. Therefore, the colour of the testicular and fat tissues on the echogram is practically identical. The testicular tissue at stage M2sf (Figure 150) is hypoechoic and appears on the screen as dark regions divided by a light strip (boundary between the fat and germinal tissues).

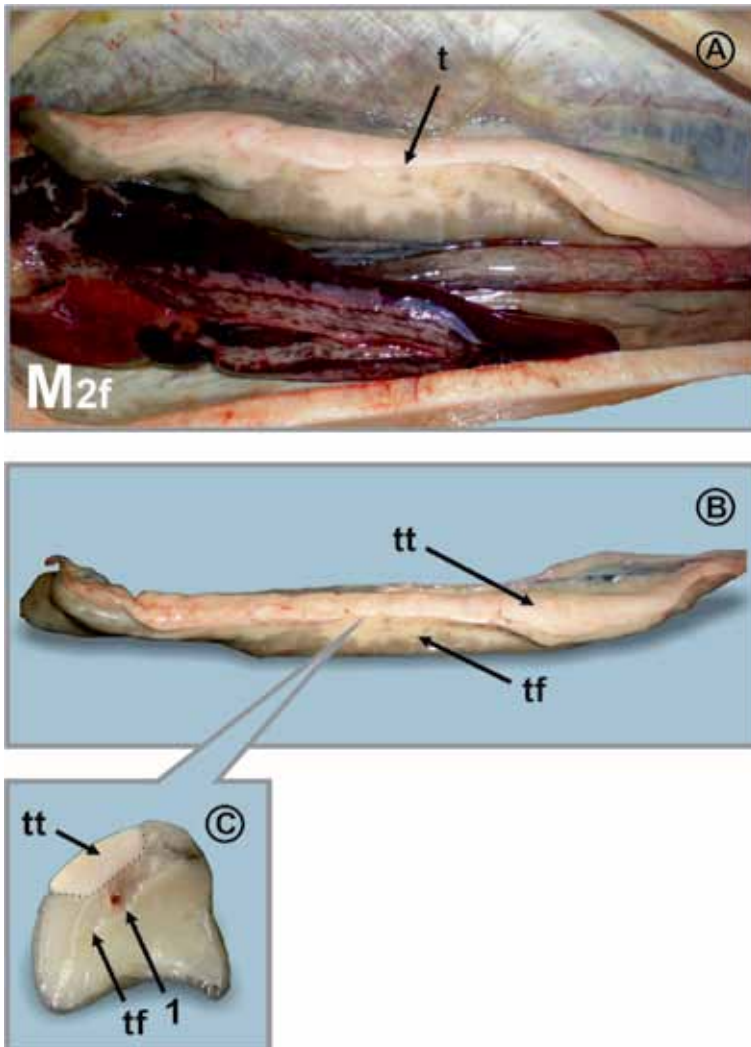
**Figure 150:** Ultrasound images of frontal and transverse sections of Siberian sturgeon male at maturity stage II semi-fatty (M2sf) (image of this specimen's gonads is presented in Figure 149).



#### 14.6.1.4 Male maturity stage II fatty (M2f)

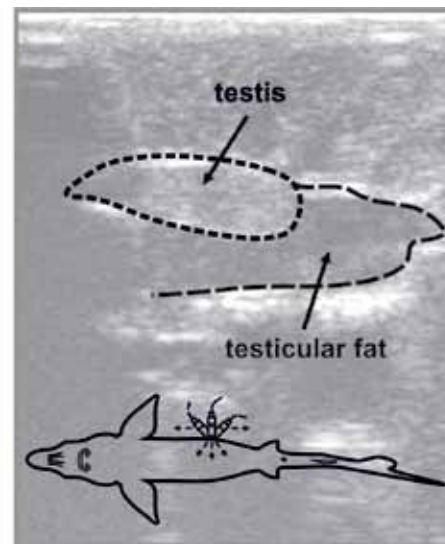
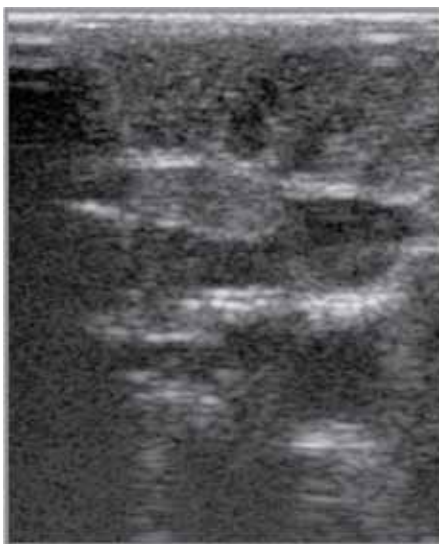
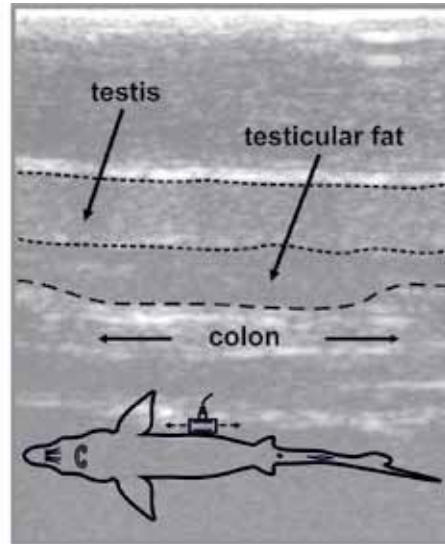
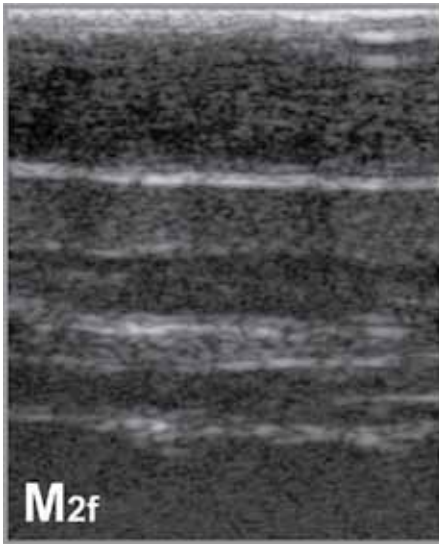
At this stage, fat deposition in the testes is associated with its accumulation in the muscles. Fat accumulation in the body cavity appears as thin strips, these being combined into a solid mass with enlarged width and depth. In the process of development from stage II to stage II fatty, the weight of the testes exhibits a 5 to 10-fold increase (fat associated). The weight of fat ranges from 80 to 95 percent of the total gonad weight. Visually, the testicular tissue is completely covered by fat (Figure 151).

**Figure 151:** Testes of Russian sturgeon at maturity stage II fatty (M2f). Fish: age – 2 years; total length/fork length– 81.5/69.5 cm; weight – 2.0 kg. Testes: weight – 45.0 (20.0/25.0) g; length – 23.0/23.5 cm; width (overall/testicular tissue) 2.3/0.7 cm. **A** – localization of testes in the body cavity (t – testis); **B** – view of testis (tf – testis fat; tt – testicular tissue); **C** – transverse section of testis (**1** – blood vessel).



The echogenicity of the testicular tissue is slightly higher than that at stage II and semi-fatty stage II. Hence, the testis becomes well discernable. The testicular tissue appears as a homogeneous, fine-grained structure (of grey colour on echograms), separated from the fat tissue (hypoechoic, dark) by a hyperechoic boundary seen as a bright white line. The testis on the transverse section appears tightly adjacent to the lateral muscles (Figure 152).

**Figure 152:** Ultrasound images of frontal and transverse sections of Russian sturgeon male at maturity stage II fatty (M2f) (image of this specimen's gonads is presented in Figure 151). Males can be easily and reliably identified on echograms starting from maturity stage II.

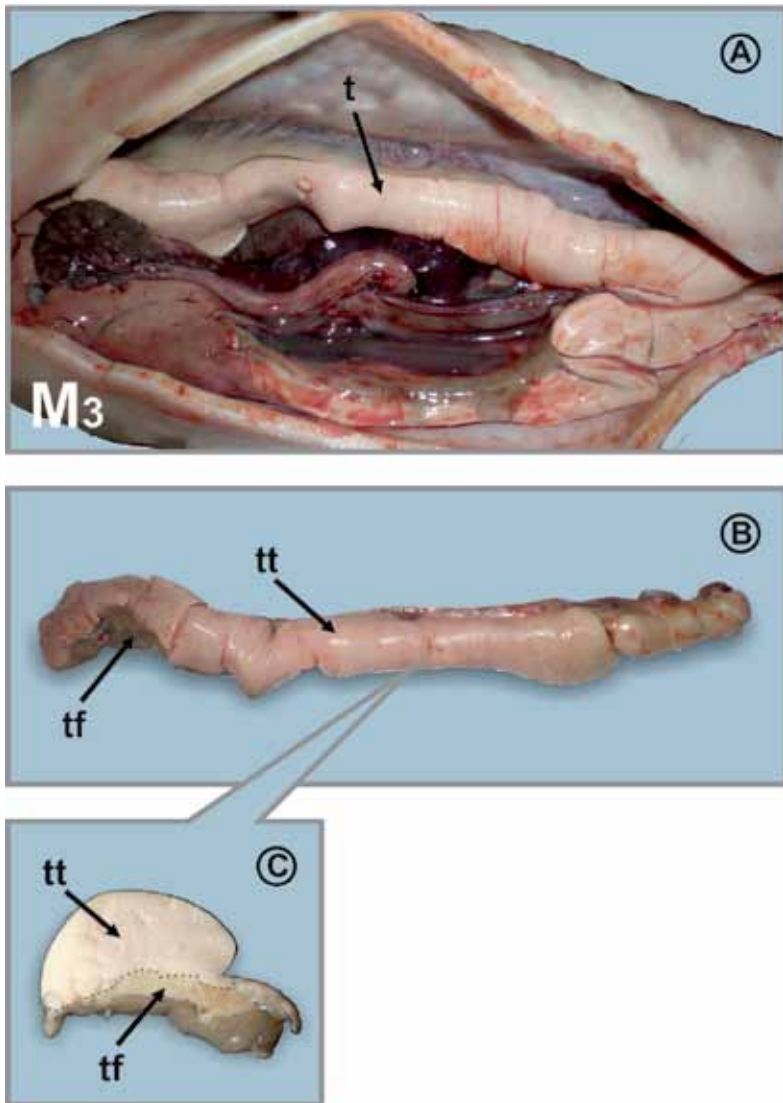




#### 14.6.1.5 Male maturity stage III (M3)

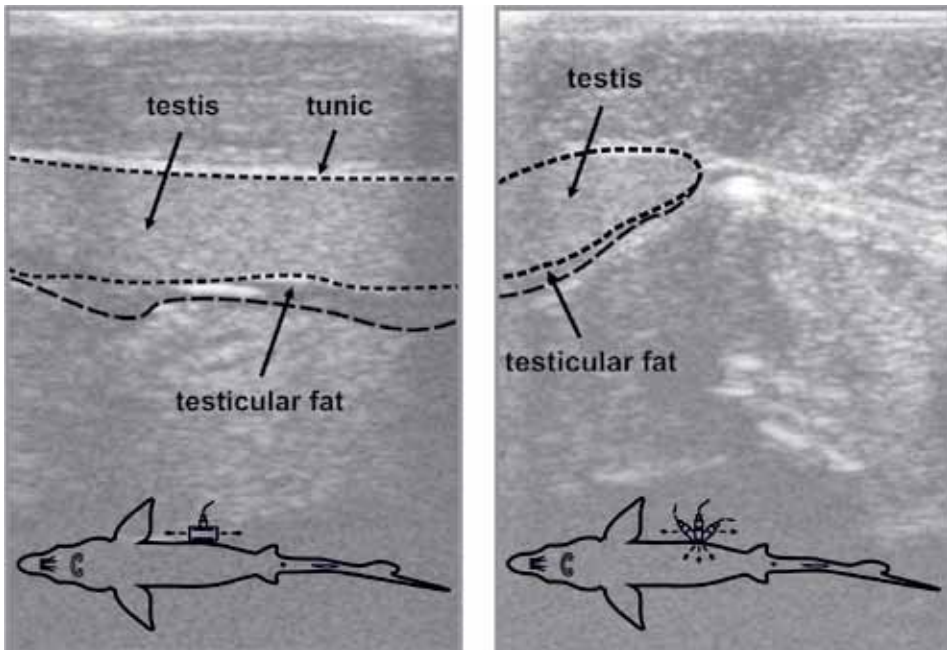
This stage is of very short duration. The fat has been almost completely used for formation of gametes (spermagonia and spermatocytes), while the testicular portion of the gonad exhibits considerable increase (Figure 153). A network of blood vessels is clearly seen on the surface of the testis; hyperaemia of the testis is observed as a result of the high level of blood circulation at this stage.

**Figure 153:** Testes of Siberian sturgeon at maturity stage III (M3). Fish: age – 2 years; total length/fork length – 81.0/68.5 cm; weight – 2.0 kg. Testes: weight 55.0 (27.5/27.5) g; length 18.0/18.0 cm; width – (overall/testicular tissue) 2.5/2.0 cm. **A** – localization of testes in the body cavity (t – testis); **B** – view of testis (tt – testicular tissue; tf - testis fat); **C** – transverse section of testis.



The testes appear on the echogram (Figure 153) as “crumpled” or “lobular” with curved margins or as rounded, hyperechoic, homogeneous structures, resulting from high rate of testicular growth during the period of cessation of linear growth of the body (typically during overwintering of fish). At maturity stage III (M3), echogenicity of the testicular tissue exhibits considerable increase (Figure 154). The testes appear on echograms as a homogeneous structure of light grey (in some cases white) colour with distinct hyperechoic margins. In some cases, two clear hyperechoic lines – gonad margins and peritoneal lining – are well discernable.

**Figure 154:** Ultrasound images of frontal and transverse sections of Siberian sturgeon male at maturity stage III (M3).

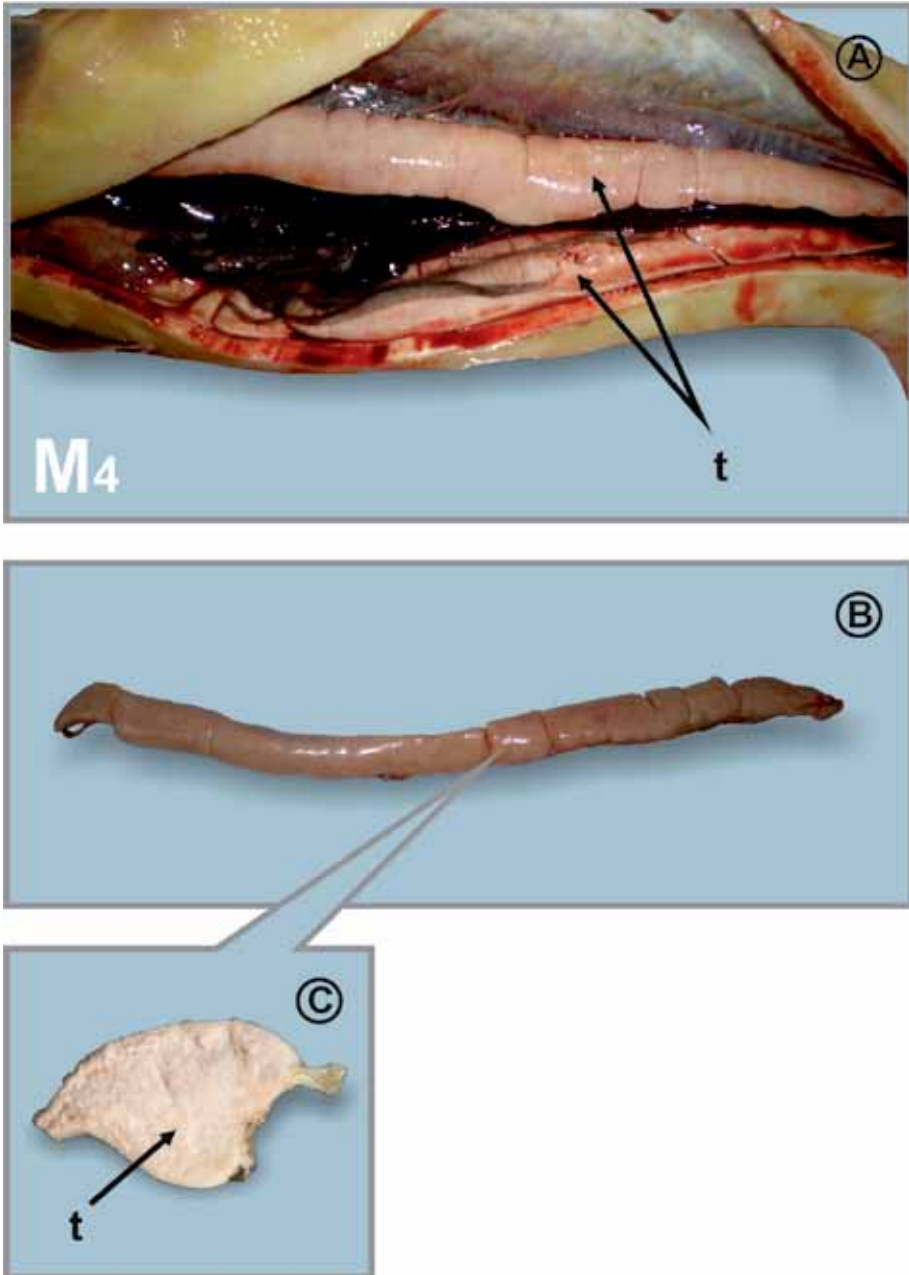


The germinal part of the testis is closely associated with the muscles. The fat on the lateral side is completely absent; a small quantity remains on the medial side, appearing on echograms as a thin hypoechoic strip.

#### **14.6.1.6 Male maturity stage IV (M4)**

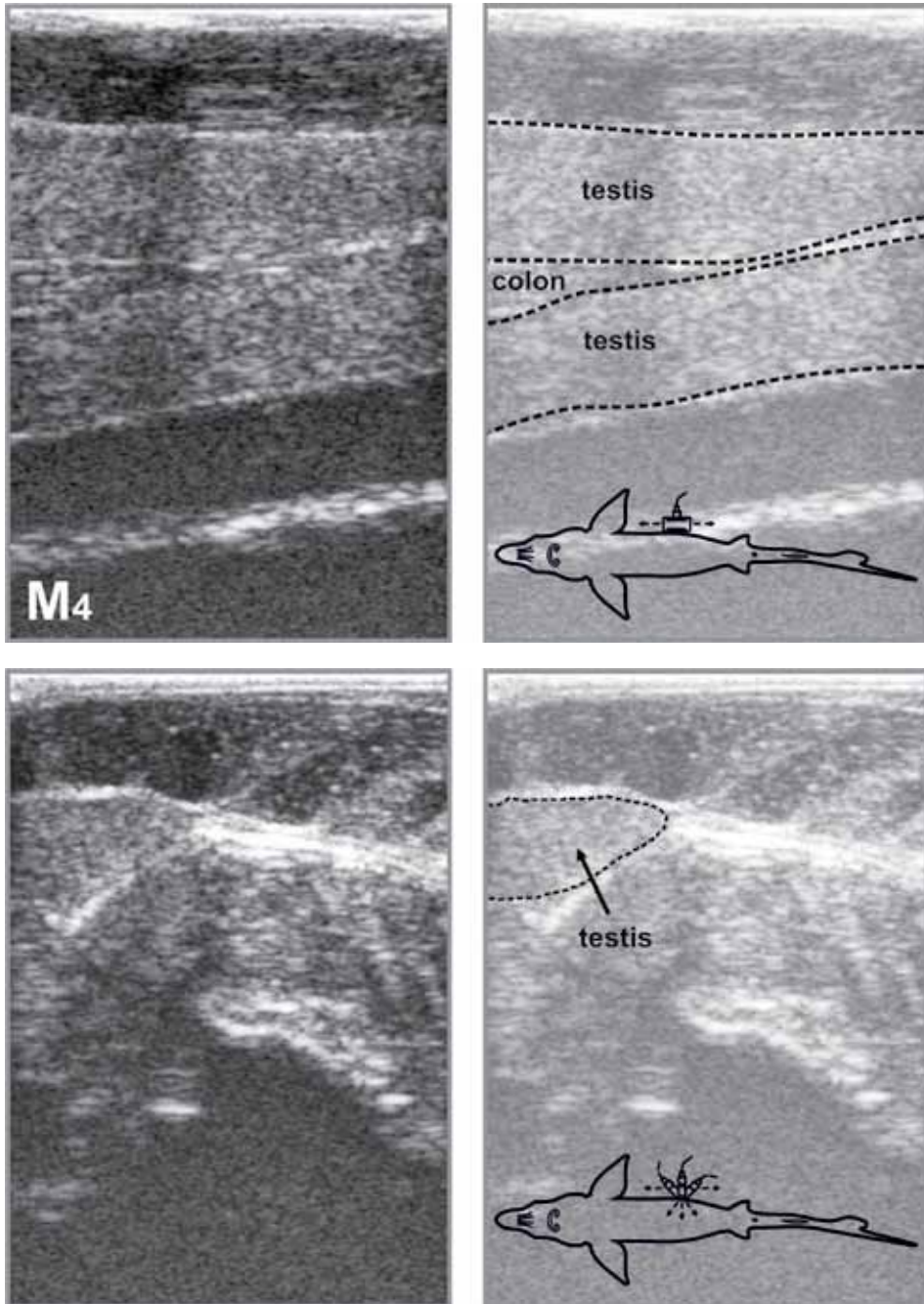
This stage is characterized by completion of the spermatogenic process. The testes become light, almost milky in colour and are almost completely deprived of fat (Figure 155). The surface of testis in early stage becomes brilliant, “as if it is covered with a thin layer of wax” (Trusov, 1972).

**Figure 155:** Testes of Russian sturgeon at maturity stage IV (M4). Fish: age – 2 years; total length/fork length – 76.0/66.0 cm; weight – 1.9 kg. Testes: weight – 65.0 (32.5/32.5) g; length – 28.5/28.5 cm; width – 1.9 cm. **A** – localization of testes in the body cavity (t – testis); **B** – view of testis; **C** – transverse section of testis.



On the echogram (Figure 156), the testes at stage IV appear as a bright, hyperechoic, fine-grained homogeneous structure with clear margins and well-defined tunics.

**Figure 156:** Ultrasound images of frontal and transverse sections of Russian sturgeon male at maturity stage IV (M4).



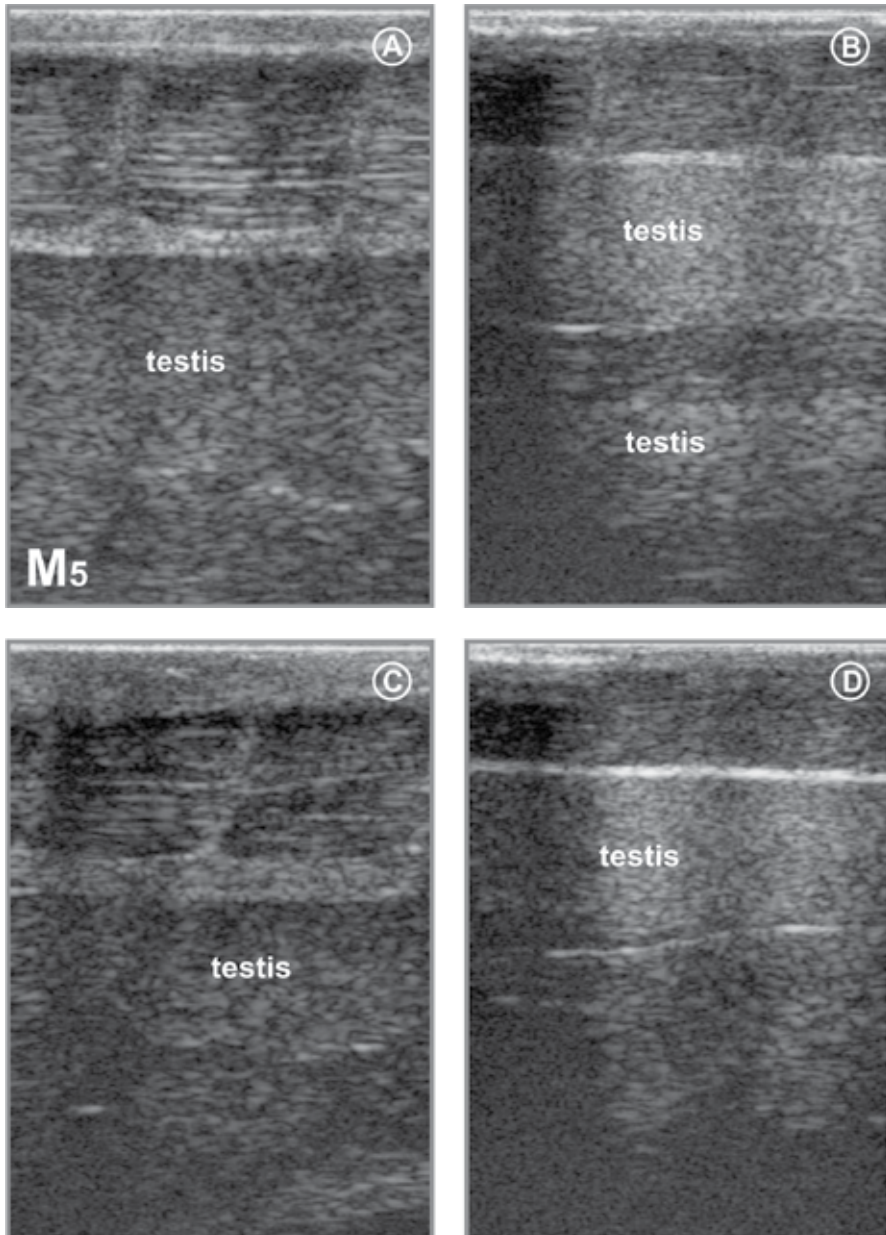
Hyperechogenicity of the testis reaches its maximum at stage IV. The ripe male maturity status and readiness to spawn can be assessed by the brightness of the testis image.



#### 14.6.1.7 Male maturity stage V (M5)

During the spawning period, the echogenicity of testicular tissue exhibits some decrease (i.e. becomes dark) as a result of seminal fluid formation (Figure 157). The medial margin of the testis becomes “fuzzy” and cannot be visualized in some cases.

**Figure 157:** Ultrasound images of frontal section of sturgeon males during spawning (M5): **A** – beluga, **B** – stellate sturgeon, **C** – Russian sturgeon and **D** – ship sturgeon. Second gonad with completely diffused margins is evident.

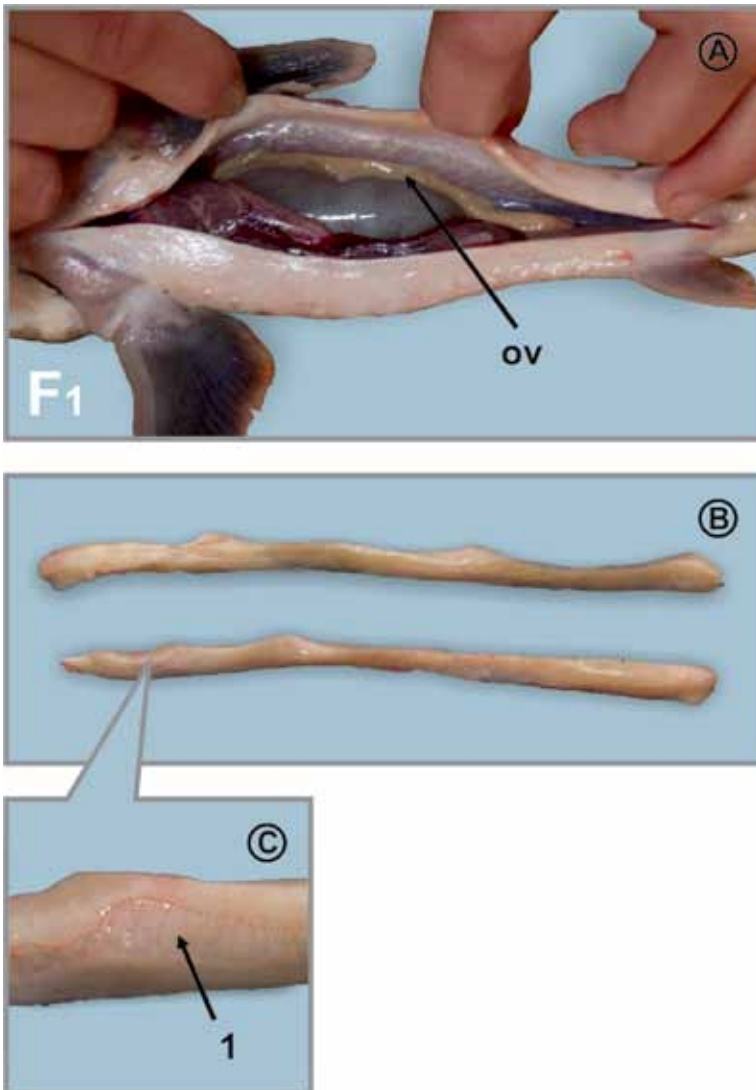


## 14.6.2 Analysis of ultrasound images of ovaries at different maturity stages

### 14.6.2.1 Female maturity stage I (F1)

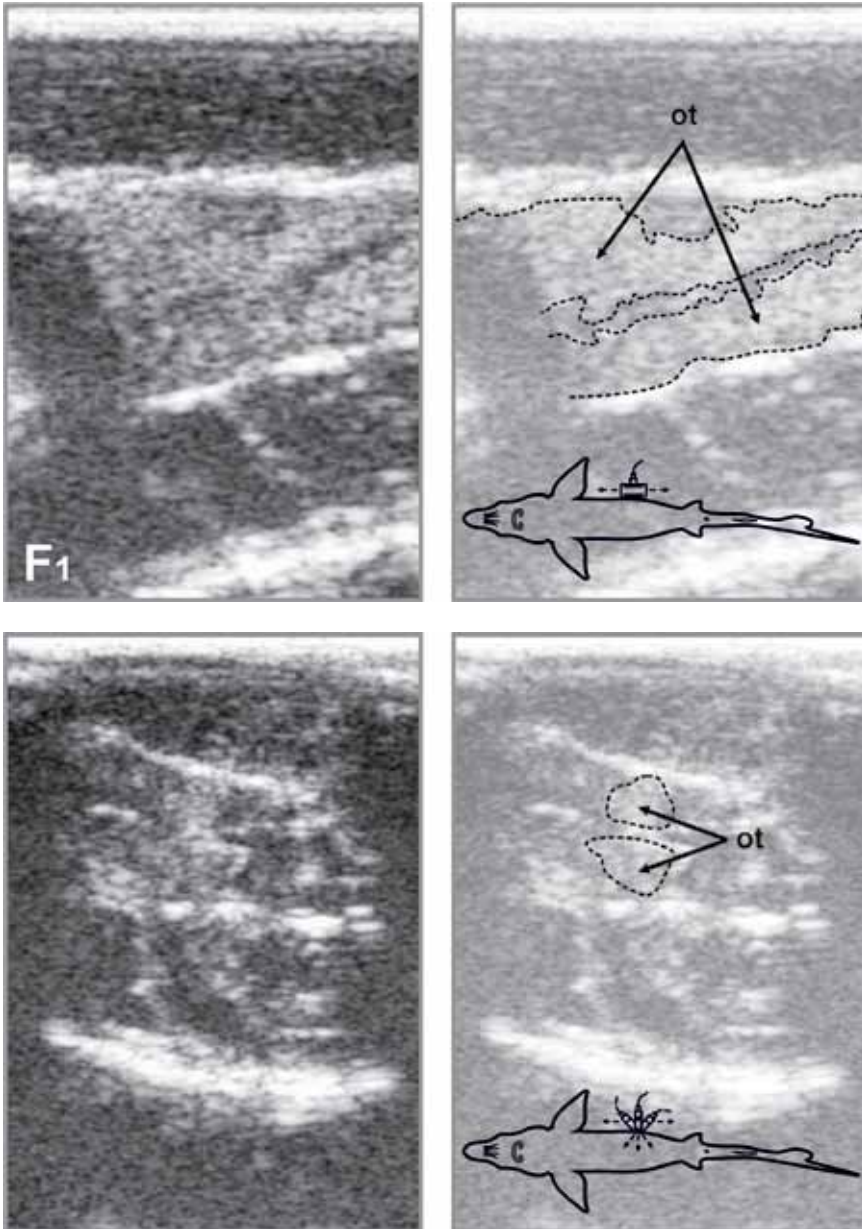
Ovarian developmental at stage I in sturgeon females is characterized by the appearance of a longitudinal fissure on the lateral side of the gonad, which is more clearly seen on the caudal part (Figure 158). Generative cells are clustered in the area of the fissure; later the formation of transverse ovigerous lamellae (Zubova, 1971; Persov, 1975) begins along all the gonad length.

**Figure 158:** Ovaries of sterlet at maturity stage I (F1). Fish: age – 8 months; total length/fork length – 41.0/35.0 cm; weight – 0.22 kg. Ovaries: length – 9.6/10.0 cm; width – 0.4 cm. **A** – location of gonad in the body cavity (ov - avary); **B** – view of ovaries; **C** – longitudinal fissure (1).



On the image of the ovaries at maturity stage I (Figure 159), as distinct from the testes, the germinal portion of the gonad is well-defined. In the frontal ultrasound image, the ovary appears as a fine-grained, moderately echogenous structure of irregular form, deprived of tunic. In the transverse image, both ovaries are well evident, but are not of significant size.

**Figure 159:** Ultrasound images of frontal and transverse sections of ovaries in female sterlet at maturity stage I (F1) (**ot** – ovarian tissue) (image of this specimen gonads is presented in Figure 158).





---

The prevalence of ovarian tissue of increased echogenicity in the gonad causes failure in identification of females at maturity stage I. To avoid cases of improper sex identification, special attention should be paid to the character of the gonad margin and the lack of tunic that can be discernable in ovary echograms by the indistinct medial margin of the gonads.

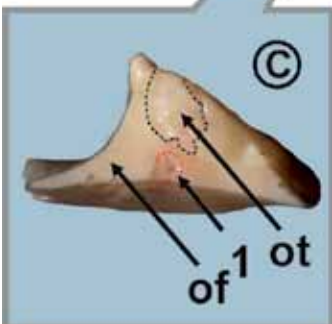
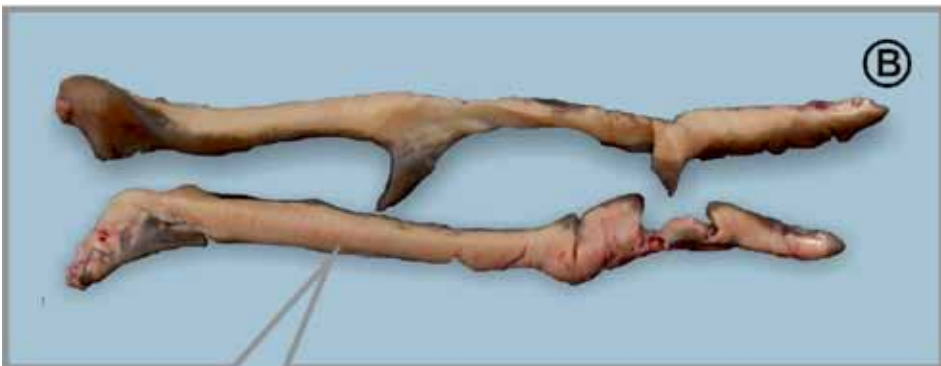
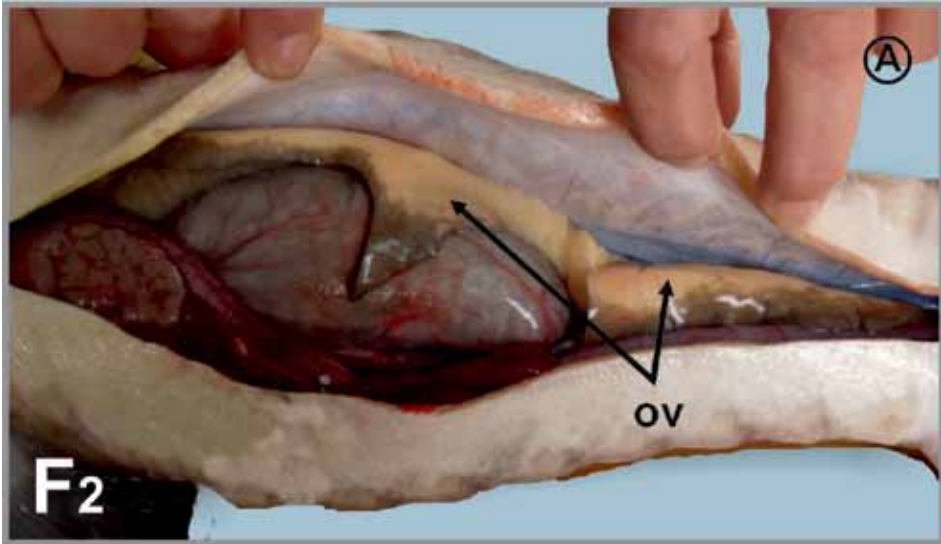
Late maturity stage I (F1) may be easily determined in the dynamic “cine mode” by prior moving of the transducer from a pelvic to a pectoral fin (at frontal scanning), the ovarian tissue appearing as a “flowing” structure of high echogenicity with uneven margins without tunics in anechoic fat. Note that stage I (F1) can be observed only in immature individuals (once during the whole life cycle). The ovaries in mature fish after spawning transit to maturity stage II.

#### ***14.6.2.2 Female maturity stage II (F2)***

At the beginning of maturity stage II, the ovaries possess little fat. At this stage (F2), fat accumulates in the germinal portion of the gonad (Figure 160), while in males, it accumulates beyond the testicular part.

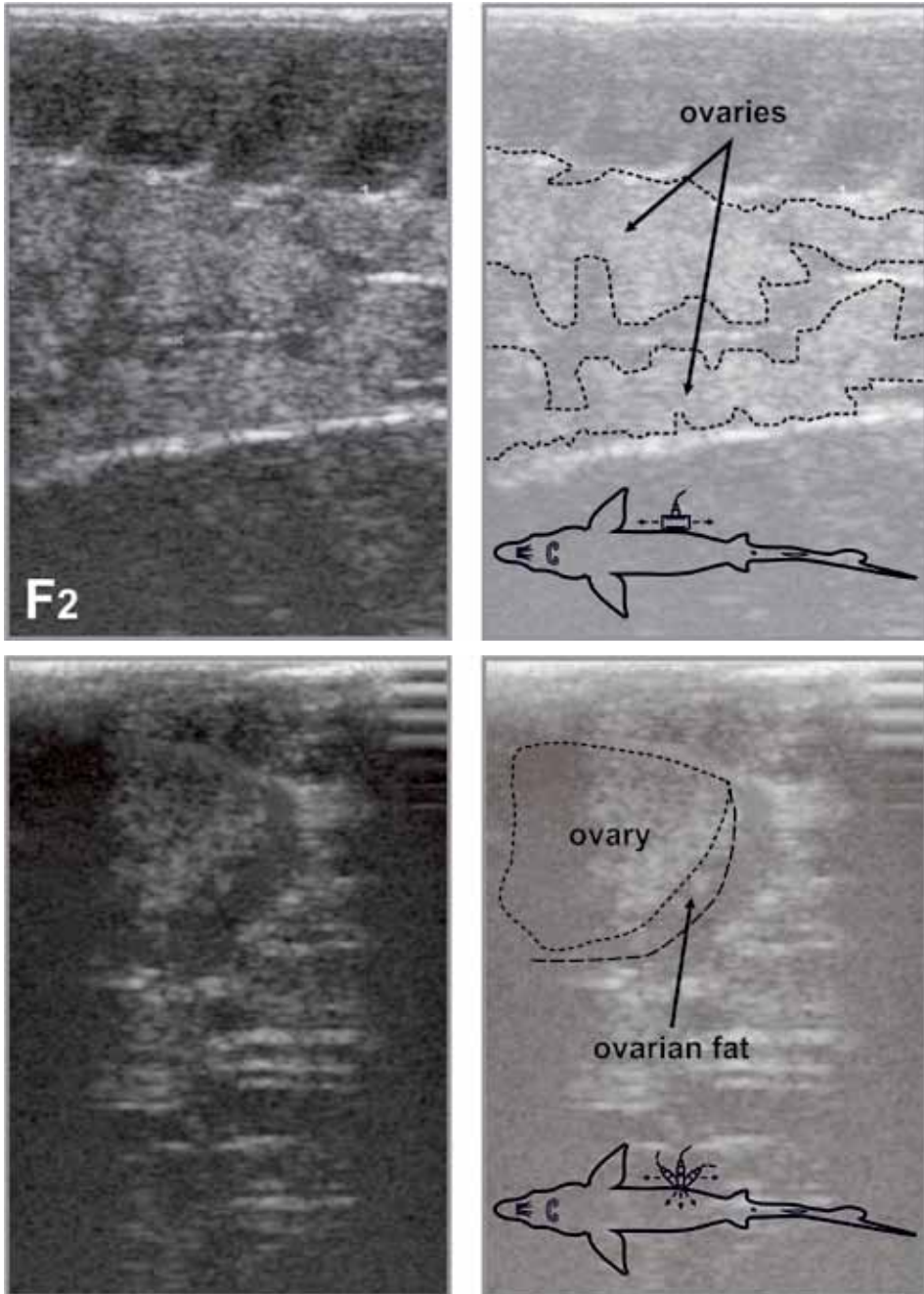
“Brain like” (Bruch, Dick and Choudhury, 2001) folds (ovigerous lamellae) are well notable from the lateral part of the ovary. The colour of the ovaries varies from pink and white to yellow and pink (Bahmani, Kazemi and Hallajian, 2005).

**Figure 160:** Ovaries of Siberian sturgeon at maturity stage II (F2). Fish: age – 2 years; total length/fork length – 78.0/63.0 cm; weight – 1.75 kg. Ovaries: weight – 33 (18.5/14.5) g; length – 26.0/23.0 cm; width – (overall/ovarian tissue) 3.0/1.1 cm. **A** – location of gonad in the body cavity (ov – avary); **B** – view of ovaries; **C** – transverse section of ovaries (ov - ovarian tissue; of - ovarian fat; **1** - blood vessel).



On the ultrasound image (Figure 161), the ovarian tissue (F2) appears as a grainy “cloud-like” structure of mixed echogenicity with uneven boundaries without tunic. The fatty portion of the ovary is slight and is visualized in the shape of the darker areas as distinct from the lighter ovarian tissue.

**Figure 161:** Ultrasound images of frontal and transverse sections of ovaries at maturity stage II (F2).

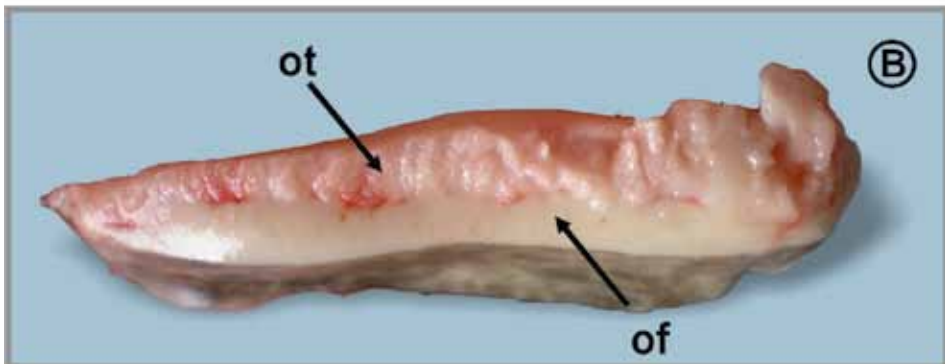
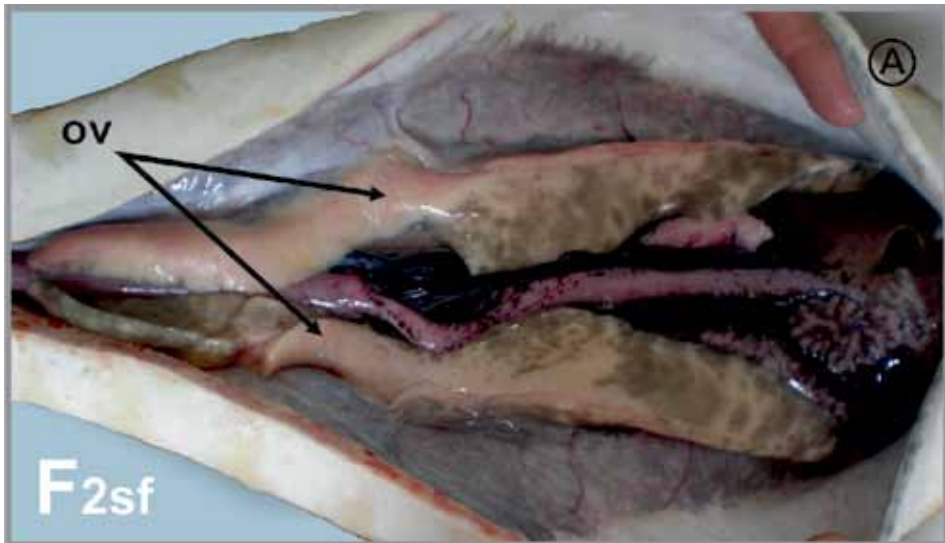


Females at stage II with ovaries of sufficient size (width of 5–6 mm) (Figure 161) can be easily identified on the frontal section.

#### 14.6.2.3 Female maturity stage II semi-fatty (F2sf)

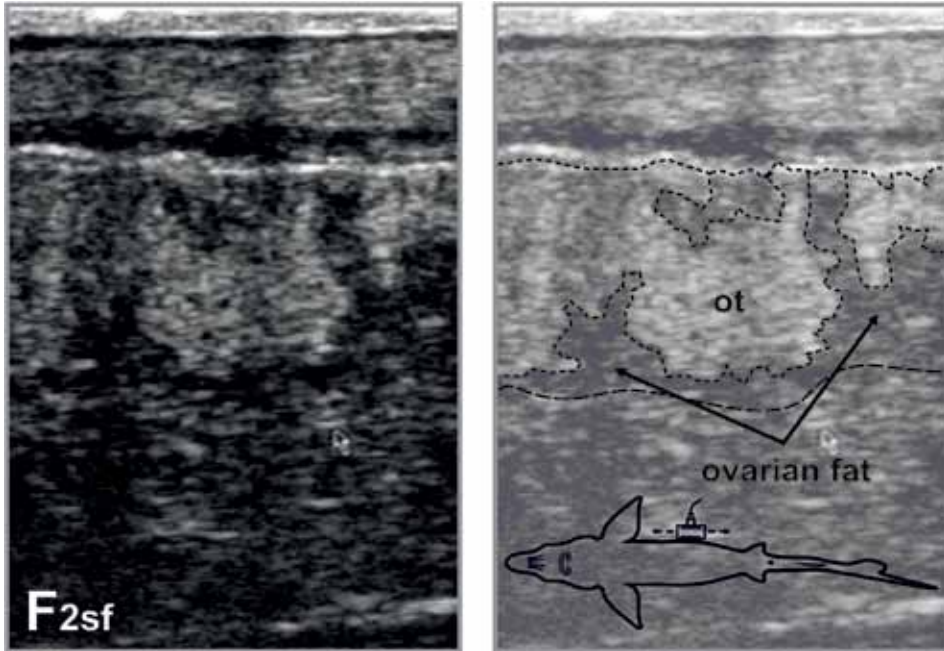
Further development of the ovaries at maturity stage II semi-fatty (Figure 162) is associated with fat deposition, which starts from the ovigerous lamellae (visually, the ovaries appear embedded in fat) and then continues on the medial and lateral sides. Once the ovarian tissue is encompassed by fat more than half of its width (being visible along the entire lateral side), the ovaries transit to stage II semi-fatty (F2sf).

**Figure 162:** Ovaries at maturity stage II semi-fatty (F2sf) in Russian sturgeon. Fish: age – 2 years; total length/fork length – 84.0/68.0 cm; weight – 2.1 kg. Ovaries: weight – 86 (44.5/41.5) g; length – 30.0/29.5 cm; width – (overall/ovarian tissue) 3.2/1.6 cm. **A** – location of ovaries in the body cavity (**ov** – ovary); **B** – transverse section of ovaries (**ot** - ovarian tissue; **of** - ovarian fat).



On the ultrasound image (Figure 163), single ovigerous lamellae appear as areas of higher echogenicity (of grey or light-grey colour) alternating with hypochoic (dark) fat regions. Thus ovigerous lamellae “grow” from the lateral to the medial part of the gonad.

**Figure 163:** Ultrasound images of frontal section of ovary at stage II semi-fatty (F2sf); ovarian tissue (**ot** - ovarian tissue).

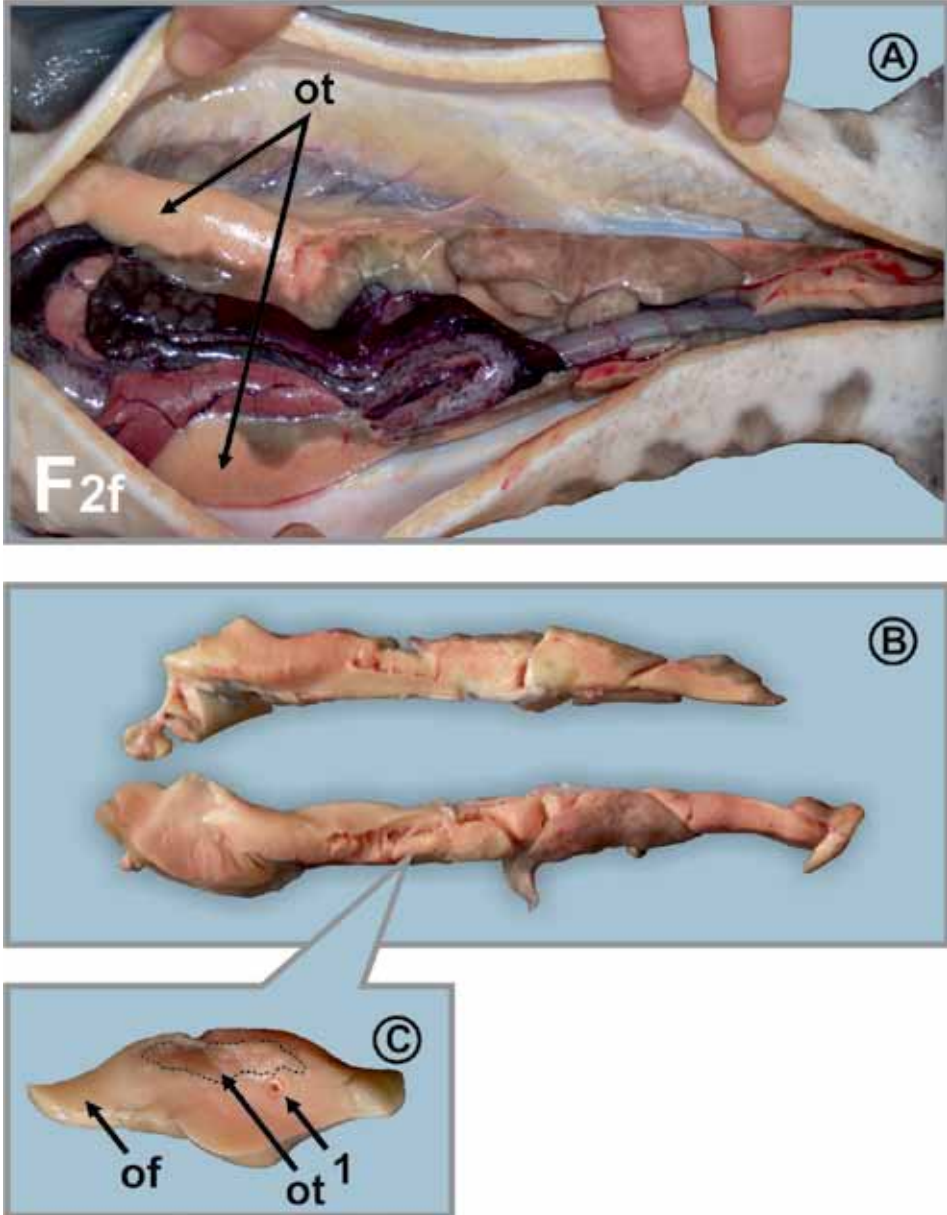


#### 14.6.2.4 Female maturity stage II fatty (F2f)

At female maturity stage II fatty, the ovaries accumulate fat on the lateral and medial sides to form a fat cover (Figure 164). Fat folds, which cover almost all ovarian tissue, are evident at the lateral side.



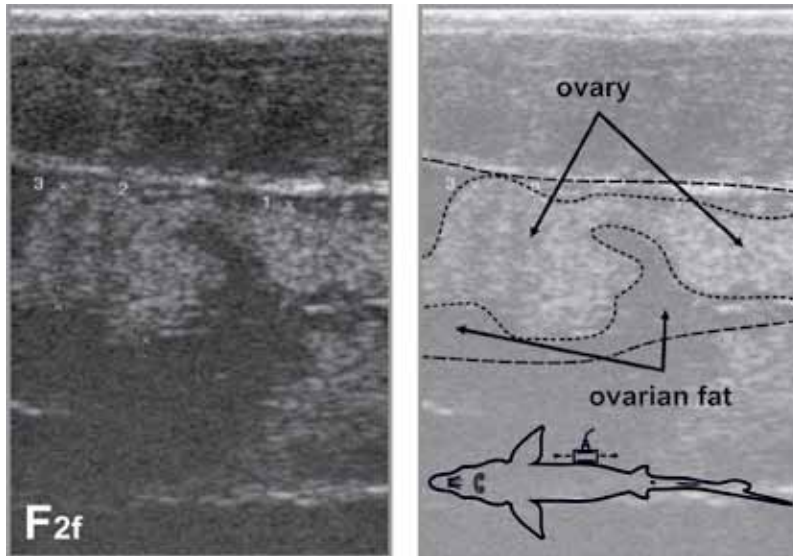
**Figure 164:** Ovaries of Russian sturgeon at maturity stage II fatty (F2f). Fish: age – 30 months; total length/fork length – 85.0/71.0 cm; weight – 3.2 kg. Ovaries: weight – 126.0 (68.5/57.5) g; length – 30.2/26.0 cm; width – (overall/ovarian tissue) 5.5/1.5 cm. **A** – location of ovary in the body cavity (**ot** – ovarian tissue); **B** – view of ovaries; **C** – transverse section of ovaries (**of** - ovarian fat; **1** - blood vessel).



In contrast to previous maturity stages, the proportion of the ovarian and fat tissue visible on echograms is different (F2f). The ovarian tissue (light, of

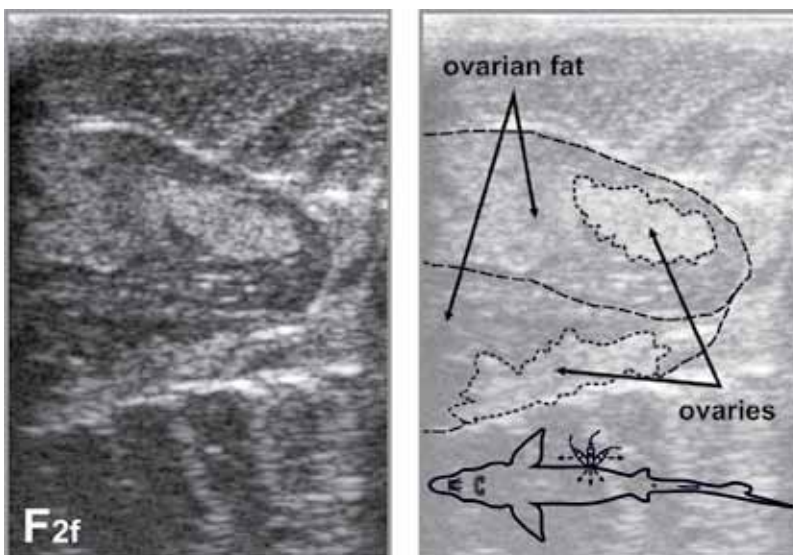
moderate echogenicity) is surrounded by fat both from the medial and lateral sides (dark, anechoic regions). The dark anechoic fat layer is well discernable between the muscles and the gonads (Figure 165).

**Figure 165:** Ultrasound images of frontal section of ovaries at maturity stage II fatty (F2f).



At transverse scanning (Figure 166), the ovarian (lighter) tissue is encompassed by the fat (darker) tissue; this is one of the most typical signs of echograms of females at maturity stage II fatty (F2f).

**Figure 166:** Ultrasound images of transverse sections of ovaries at maturity stage II fatty (F2f).

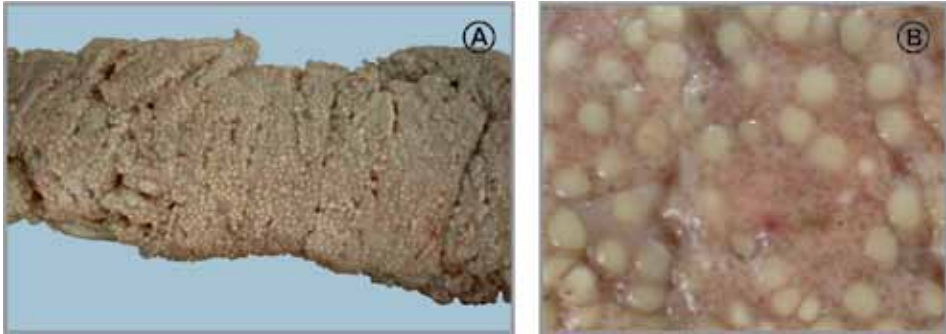




#### 14.6.2.5 Female maturity stage II–III (F2–3)

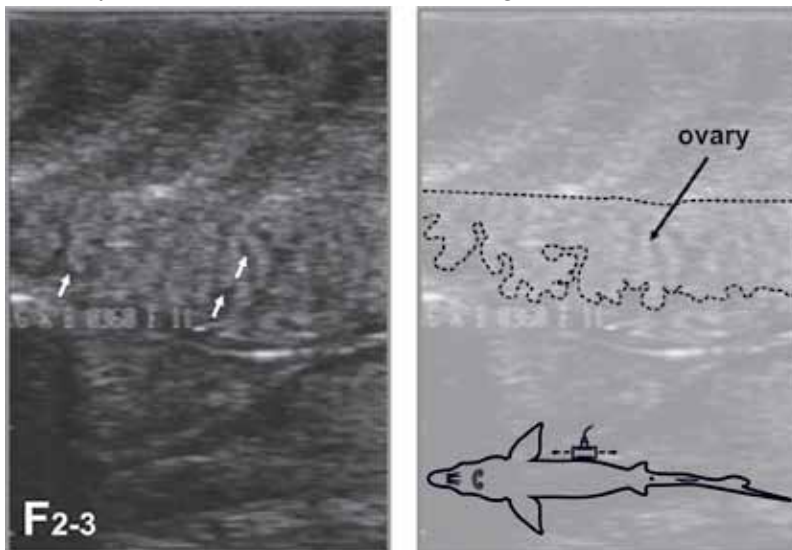
At the onset of vitellogenesis, the further maturation of the ovaries is associated with the trophoplasmatic growth of oocytes due to ongoing yolk synthesis. The gonads tend to possess less fat, the ovarian tissue becoming more evident (Figure 167). The oocytes of the senior generation (diameter of about 0.5 mm) protrude above the lateral part of the ovary and attain a bright yellowish colouration associated with the formation of fat droplets in the cytoplasm.

**Figure 167:** View of ovary: **A** – at maturity stage II–III (F2–3); **B** – enlarged view of oocytes of senior generation.



An ovary seen in the ultrasound image (Figure 168) shows moderate echogenicity (grey or light grey). Ovigerous lamellae “penetrate” the body of the gonad and appear as a brachiate vertical structure (“coral-like” or “fringed” in shape) of higher echogenicity, spreading to the dark hypoechoic region (the fat tissue).

**Figure 168:** Ultrasound images of frontal section of ovaries at maturity stage II–III (F2–3) (My Sono-201). Arrows indicates ovigerous lamellae.

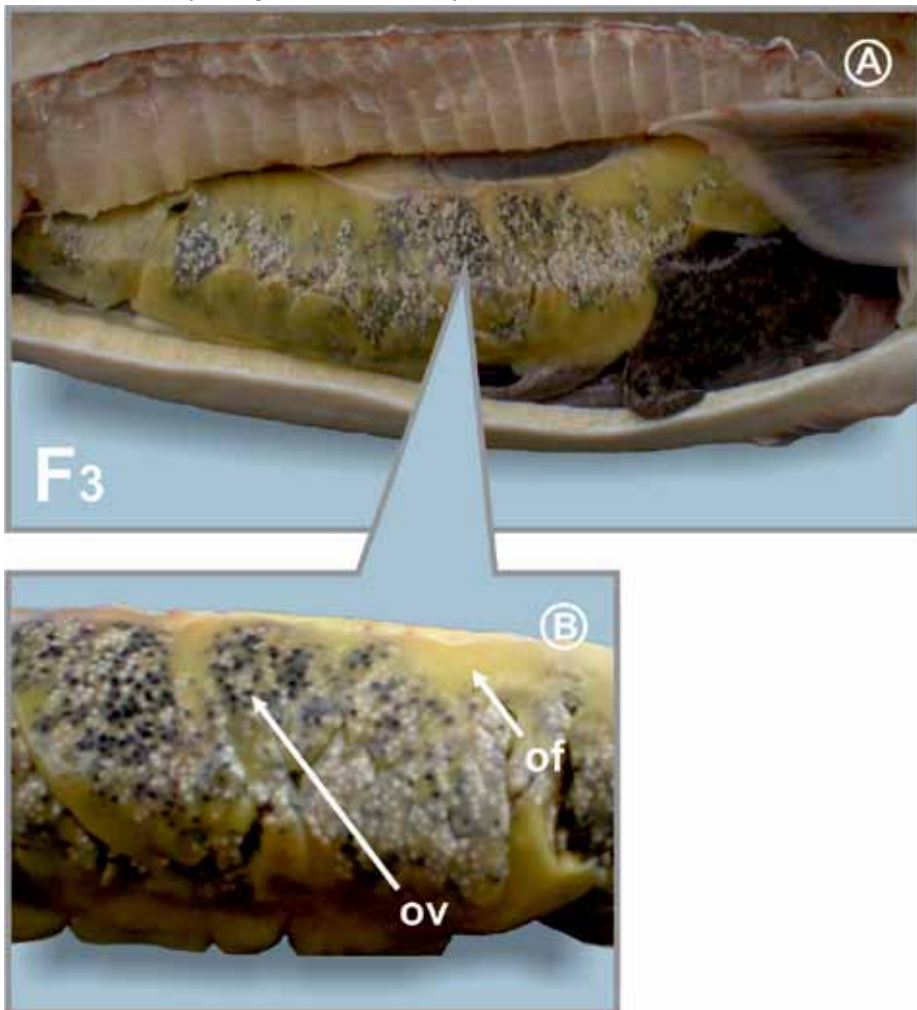


#### 14.6.2.6 Female maturity stage III (F3)

Transition of the ovaries to maturity stage III (Figure 169) is characterized by growth of follicles, thickening of the ovigerous lamellae and increase in linear size and volume of gonads. The fat content in the ovary during the onset of vitellogenesis shows considerable decrease.

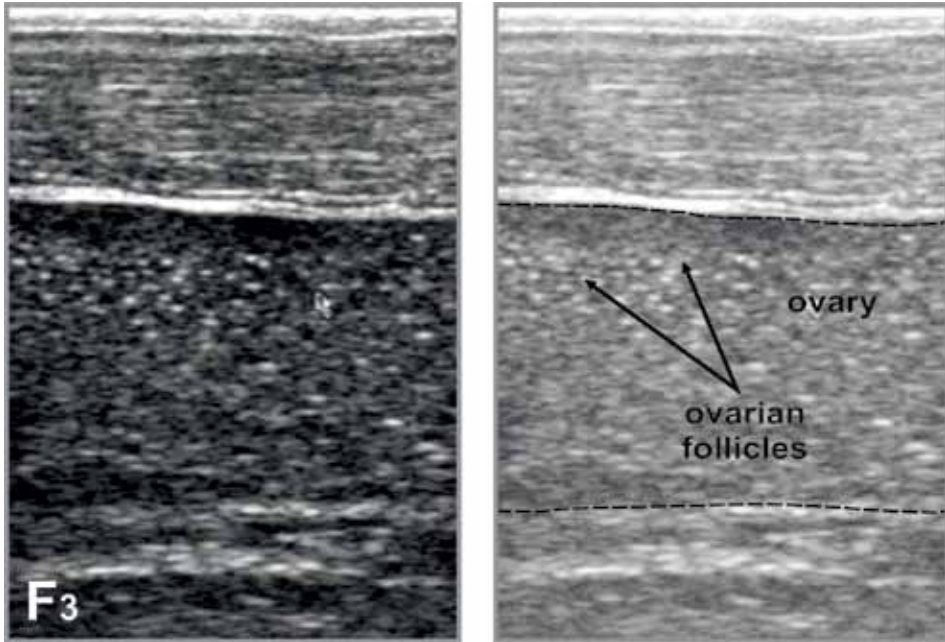
The size of white oocytes increases, and oocytes of greyish colouration can be encountered. The nuclear polarization of pigmented oocytes is not well evinced. At the end of the stage, completely pigmented (grey) oocytes prevail among oocytes of the senior generation and reach a diameter of 1.6–2.6 mm in Russian sturgeon. This is an important visual sign of maturity stage III.

**Figure 169:** View of ovaries at maturity stage III (F3) in sterlet. Fish: age – 4 years; total length/fork length – 69.0/54.0 cm; weight – 1.9 kg. Ovaries: weight – 205 (101/104) g; length – 25.0/25.5 cm. **A** – location of ovaries in the body cavity; **B** – view of ovary (stage F3) (**ov** - ovary, **of** - ovarian fat).



On the ultrasound image, ovaries at stage III appear as a clear granular texture (Figure 170). In the sequel, small regions of ovigerous lamellae can be evident only in the lateral part of the ovary. Gonad enlargement and yolk deposition in oocytes leads to absorption of echosignal in the ovary; thus the organs located below can hardly be identified on echograms.

**Figure 170:** Ultrasound images of frontal section of ovary at the end of maturity stage III and onset of stage IV (F3–4).

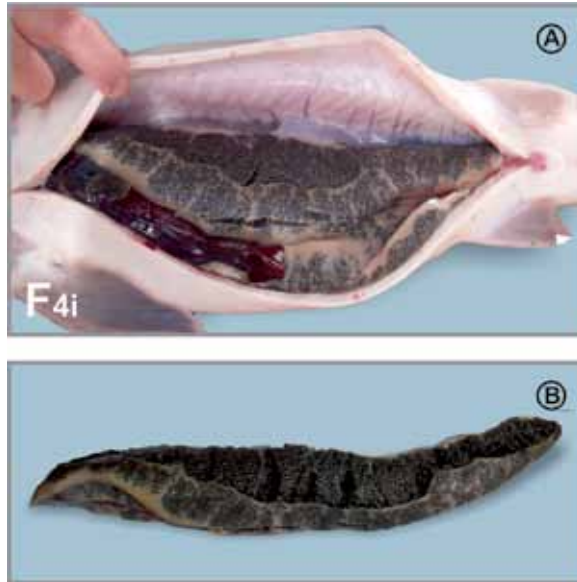


On the frontal ultrasound image of the ovary at late maturity stage III – onset of stage IV, small individual oocytes of varying sizes are discernable immediately below the muscle tissue. The gonad can be visualized almost completely in small fish. Note that maturity stage III has short duration, traditionally passing during summer fish holding, and thus can be rarely observed during ultrasound diagnostics.

#### ***14.6.2.7 Female maturity stage IV incomplete (F4i)***

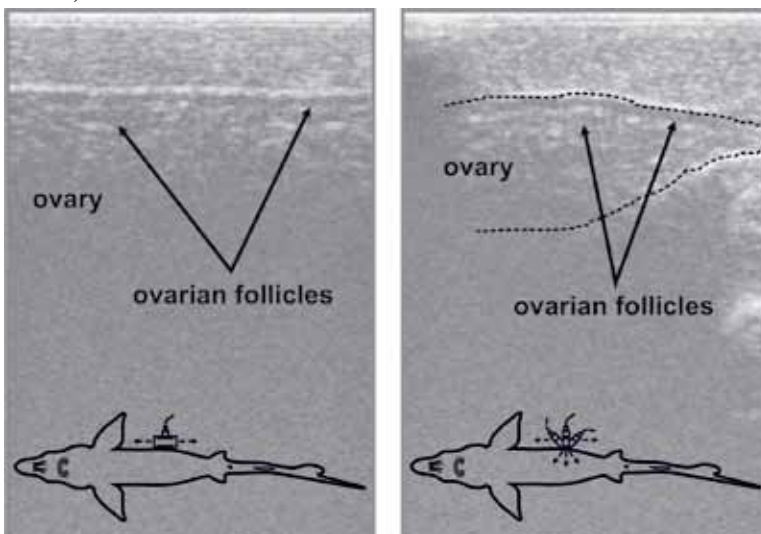
At female maturity stage IV incomplete, all the oocytes of the dark-grey colour are close to definitive size (Figure 171).

**Figure 171:** Ovaries of sterlet at maturity stage IV incomplete (F4i). Fish: age – 30 months; total length/fork length – 73.0/57.0 cm; weight – 2 kg. Ovaries: weight – 267 g; length – 29.3/29.0 cm. A – location of ovaries in the body cavity; B – view of ovary (stage F4i).



Single large oocytes of equal size are well discernable on the images (Figure 172). The ability of the ovaries to let through ultrasound waves is considerably reduced and the medial side of the gonad and the organs located below cannot be visualized.

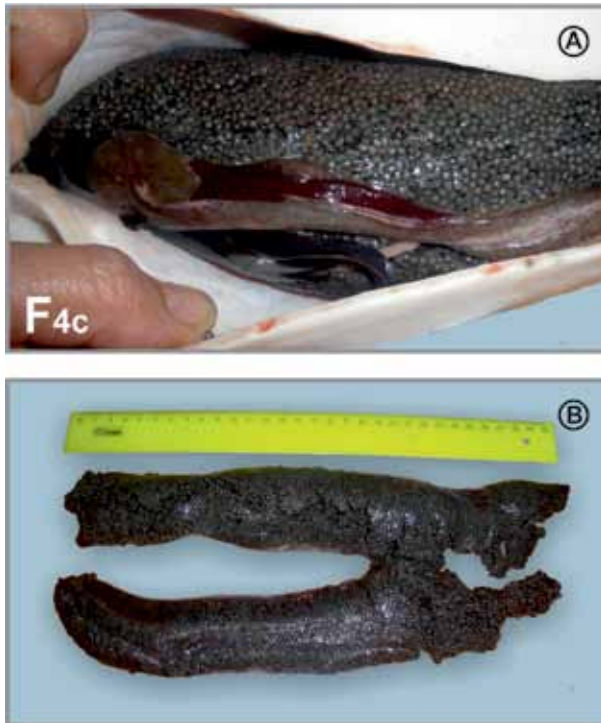
**Figure 172:** Ultrasound images of frontal and transverse sections of ovary at the incomplete maturity stage IV (F4i) (image of this specimen's gonads is presented in Figure 171).



#### 14.6.2.8 Female maturity stage IV complete (F4c)

Maturity stage IV complete (F4c) is responsive-state gonadal development. The lack of fat is evident (Figure 173), while the ovaries fill almost the entire body cavity, and completely pigmented oocytes (black in colour) reach the definitive size.

**Figure 173:** Location of gonad in the body cavity of sterlet at maturity stage IV complete (F4c). Fish: age – 30 months; total length/fork length – 74.0/61.0 cm; weight – 2.1 kg. Ovaries: weight – 383 g; length – 31.5/30.0 cm. **A** – location of ovaries in the body cavity; **B** – view of ovaries.

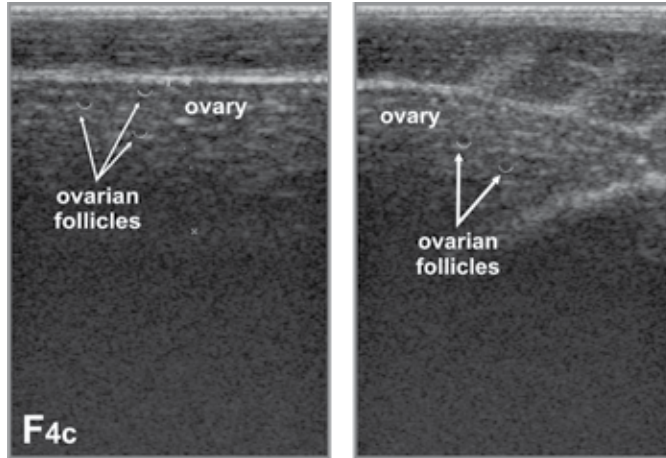


On the image shown in Figure 174, single oocytes are evident as granular inclusions of almost equal size, and the ovary shows a granular heterogeneous appearance (Chebanov, Galich and Chmyr, 2004; Chebanov and Galich, 2009). Lines of oocytes become more apparent. At this stage, ultrasound is almost completely absorbed in the upper (1 cm) layer of the ovary, and hence the medial part of the gonad and organs below are not discernable. The key differences between echograms of ovarian maturity stages IV complete and IV incomplete are as follows:

- amore evident lines of oocytes of equal size;
- the higher absorption of echosignal by the upper layer of mature oocytes; and
- absence of visualization of the medial part of the ovary.



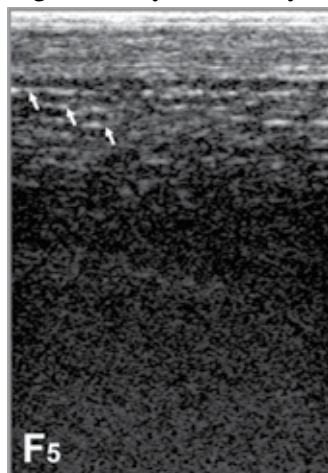
**Figure 174:** Ultrasound images of frontal and transverse sections of ovary at maturity stage IV complete (F4c) (image of this specimen's gonads is presented in Figure 173).



#### ***14.6.2.9 Female maturity stage V (F5) - spawn***

On the image shown in Figure 175, the ovulated eggs of equal size arranged in rows are well defined. This is a primary visual distinction of echograms at the frontal scanning of the ovaries at stage of maturity V from stage IV complete. The effect of distal acoustic enhancement is registered due to considerable accumulation of fluid under the rows of oocytes that is manifested as white (hyperechoic) dashes on the screen, providing more contrast than seen in images of stage IV. Note that the above-mentioned differences between ovary development stage IV complete (F4c) and stage V (F5) allow accurate timing of complete egg ovulation, which is very important for hatchery practice. To avoid affects of stressors, in order to evaluate the rate (degree) of ovulation in large sturgeons (e.g. beluga), it is recommended to use ultrasound techniques while the fish is held in water.

**Figure 175:** Ultrasound image of ovary at maturity stage V (F5).



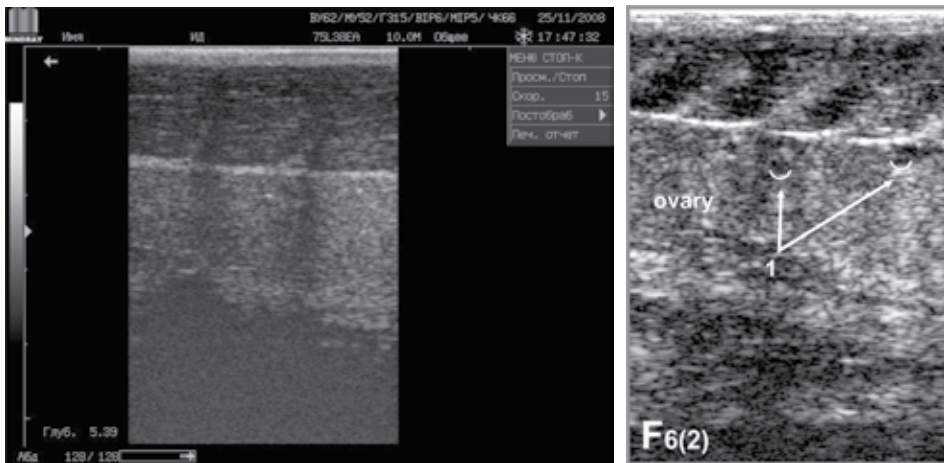
#### 14.6.2.10 Female maturity stage VI (F6)

After natural spawning or artificial nonlethal egg extraction from ripe females, resorbing mature oocytes and oocytes of the junior generation remain in the ovary. Ovaries of post-spawn fish transit to maturity stage II.

Typical images of the ovaries at maturity stage IV are presented in Bruch, Dick and Choudhury (2001), who reported that “ovaries immediately after spawning are folded, the ovarian tissue appears less organized, and in most samples has a mushy, punkish and flaccid appearance with little to no associated fat.”

The ultrasound images of the ovaries at maturity stage VI (Figure 176) are similar to those of the ovaries at stage II, while the presence of residual resorbing mature oocytes is the primary difference between these echograms. The ovarian tissue of the gonad is of moderate echogenicity. Immediately after spawning/extraction by microsurgery of the oviduct (Podushka, 1999), oocytes of the junior generation are not well evident due to their small size (0.2–0.4 mm).

**Figure 176:** Ultrasound image of frontal section of ovaries, 10 months post-extraction of ovulated eggs.



Note that ultrasound images of post-spawn sturgeons are slightly different from those of first-spawning fish. This is related to fat deposition in the ovary and sclerotization of haematomas and breaks in the ovarian tissue, which is represented by a region of mixed echogenicity. In addition, the ovaries in post-spawn sturgeons have considerably larger size than that of those at first maturity. This is well evident on the vertical measuring scale at the left side of the echogram.

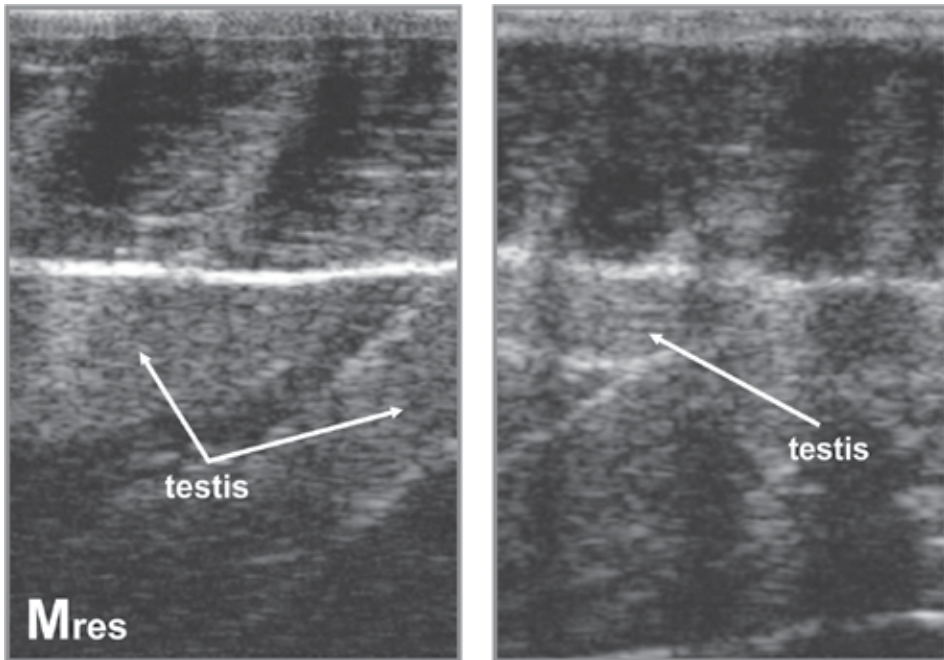


### 14.6.3 Ultrasound images of testes and egg resorption

#### 14.6.3.1 Males

During the summer season at hatcheries/farms of the industrial type, as well as at long-term holding, overripe males and resorption of the testes can be observed, being expressed by strong hyperemia and “loosening” of the testes. On the ultrasound image, this process is expressed by reduction in testis echogenicity (Chebanov, Galich and Chmyr, 2004; Chebanov and Galich, 2009). At the onset of this stage, tunics and margins of the testis are well-defined (Figure 177), while during further overripening, they become less clear.

**Figure 177:** Ultrasound images of resorbed testes in post-spawn male (early resorption).

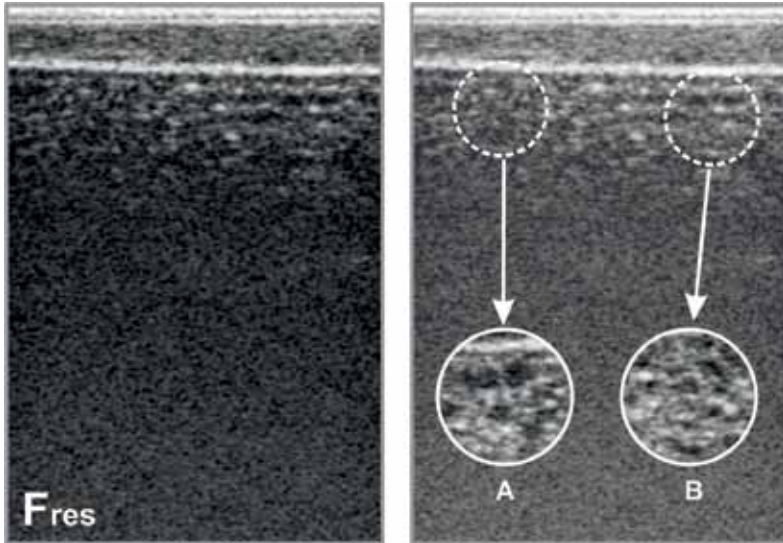


#### 14.6.3.2 Females

In the case of exposure of mature females (F4c) to spawning temperature for more than 20 days, resorption (atresia) of mature (ripe) oocytes and follicular epithelia occurs in the ovaries or in the body cavity (Goncharov *et al.*, 2009). On the ultrasound image (Figure 178), this process is expressed in the following way: echogenicity of the ovary is decreasing and residual mature oocytes become irregular in shape and lose distinct margins (A), and oocytes of the junior generation (B) are evident between resorbing eggs (oocytes).

In some cases, after extraction of ovulated eggs for reproduction (or caviar production) or after natural spawning, the gonads (F6) exhibit a considerable decrease in size and lose their previous echogenic structure. The sex of such fish is difficult to identify on the echogram.

**Figure 178:** Ultrasound image of female at stage VI (Fres) with eggs in the process of early resorption. **A, B** – enlarged areas of the ultrasound image.



Note that timely ultrasound diagnostics of the onset of partial oocyte resorption allows avoidance of full resorption of ripe ovarian follicles by control of the thermal regime or the immediate use of mature females for artificial reproduction. In some cases, when the process of resorption has been transferred to a considerable part of the ovary, ultrasound diagnostics can help avoid the inefficient use of females of rare and endangered species (*ex situ* and *in situ*) in the spawning campaign. This is especially important in the case of *A. sinensis* (Figure 179) and *A. sturio*, for which the use of traumatic techniques (e.g. biopsy, laparoscopy, endoscopy) during examination and holding is undesirable (FAO, 2008).

**Figure 179:** Anaesthesia of a large Chinese sturgeon specimen (using MS-222 sedative).



#### 14.6.4 Noninvasive ultrasound monitoring of gonadogenesis of large sturgeon specimens

Due to the large size of specimens of some sturgeon species (e.g. kaluga, Beluga, Chinese and white sturgeon), the use of a conventional linear transducer (frequency range of 5–10 MHz) in ultrasound scanning is less effective because of its high frequency-associated small depth of scanning (penetration), despite the high resolution of the resulting images (Chebanov, 2005). Hence, the main type of transducer to be used while scanning large specimens is a convex one (Figure 180) with frequencies of 2–3.5 MHz and depth of ultrasound penetration above 20 cm. Unfortunately, this transducer has comparatively low resolution (Chebanov and Galich, 2009).

**Figure 180:** Noninvasive ultrasound stress-free examination of sex and stage of a large specimen of Chinese sturgeon (scanning is conducted while fish is kept in water).

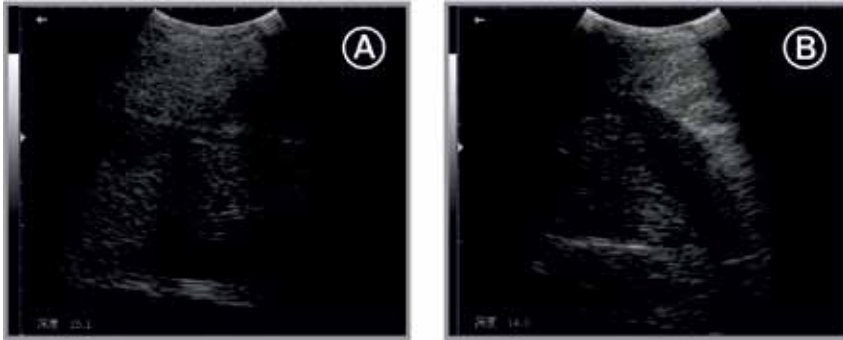


However, in some cases (especially at high air or water temperature), administration of an anaesthetic should be conducted for larger specimens (above 80 kg) in the tank (with depth of 40–50 cm) (Section 5.1.3).

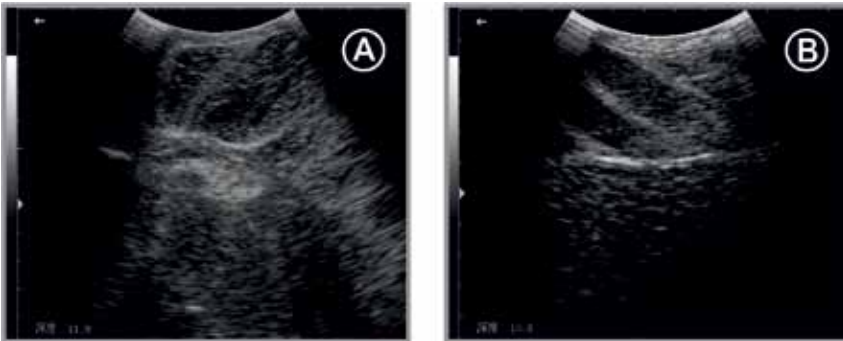
Ultrasound images of Chinese sturgeon with indication of fish sizes and depth of scanning from the body surface (cm) are presented in Figures 181 to 183. Differences between the various stages of maturity of males and females meet the previously described diagnostic markers (Sections 14.6.1 and 14.6.2).

Ultrasound examinations were conducted in frontal and transverse modes of B-scanning (Figures 181 to 183).

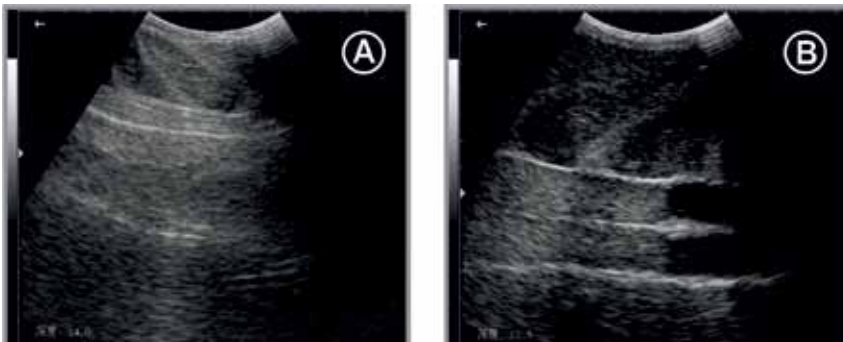
**Figure 181:** Ultrasound images of ovary of Chinese sturgeon female at maturity stage II fatty (F2f) (total length/fork length – 233/200 cm). **A** – frontal section; **B** – transverse section.



**Figure 182:** Ultrasound images of the ovary of Chinese sturgeon (total length/fork length – 212/195 cm, weight – 85 kg). **A** – transverse ultrasound image of Chinese sturgeon female at maturity stage II fatty (F2f); **B** – frontal ultrasound image of Chinese sturgeon female at maturity stage IV incomplete (F4i).



**Figure 183:** Ultrasound images of frontal section of Chinese sturgeon males. **A** – testis maturity stage II (M2) (total length/fork length – 180/155 cm); **B** – testis maturity stage III (M3) (total length/fork length – 180/162 cm).



Note that the constant monitoring of gonadogenesis of sturgeons in domestic broodstock allows, as has been mentioned above, the prevention of resorption of mature oocytes through timely regulation of thermal regime, water current velocity and feed deprivation. In addition, it is possible to avoid stress by keeping large fish in water while performing a number of ultrasound examinations.

#### **14.7 ULTRASOUND DIAGNOSTICS OF DEVELOPMENTAL ANOMALIES IN THE REPRODUCTIVE SYSTEM OF STURGEON (PATHOLOGIC ECHOANATOMY)**

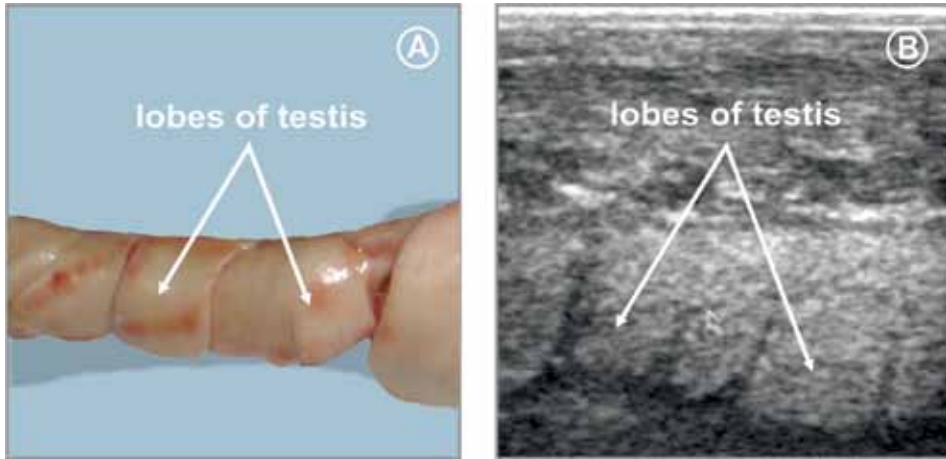
Application of the noninvasive express method allows the culling of sturgeon individuals with abnormalities of the reproduction system: these fish not being promising for hatchery propagation. Moreover, the identification of various malformations on the ultrasound images enables the monitoring of sturgeon reproductive system development. In a similar way, it can be conducted in natural waterbodies as a bioecological indication of habitat degradation, as well as in the assessment of broodstock holding conditions (e.g. thermal regime, water quality, diet formulation) in aquaculture or for the evaluation of selection effect in breeding programmes for domesticated forms and strains of sturgeons (Chebanov, Galich and Ananyev, 2008). Hence, the development of functional diagnostic methods allows the efficiency of sturgeon health evaluation to be enhanced, especially for domestic broodstocks of rare and endangered species, where the prolonged feeding of pelleted feeds (e.g. with high fat level) can lead to serious damage (degeneration) of the liver and other organs. Application of the express technique will be especially useful for wild breeders (Moghim *et al.*, 2002) and the preselection of immature sturgeon intended for predomestication (adaptation to artificial holding conditions) (Bilio, 2007). In fact, due to the labour intensiveness and high cost of long-term domestication of “wild” fish, the efficiency of preculling of individuals with “hidden” pathology of the inner organs using ultrasound diagnostics can hardly be overestimated.

##### **14.7.1 Lobularity of testes**

Lobularity of testes (Figure 184) is the division of the testicular tissue into lobes that are smaller than normal. In this situation, hypoechoic (dark) strips are evident on the ultrasound image at frontal scanning.



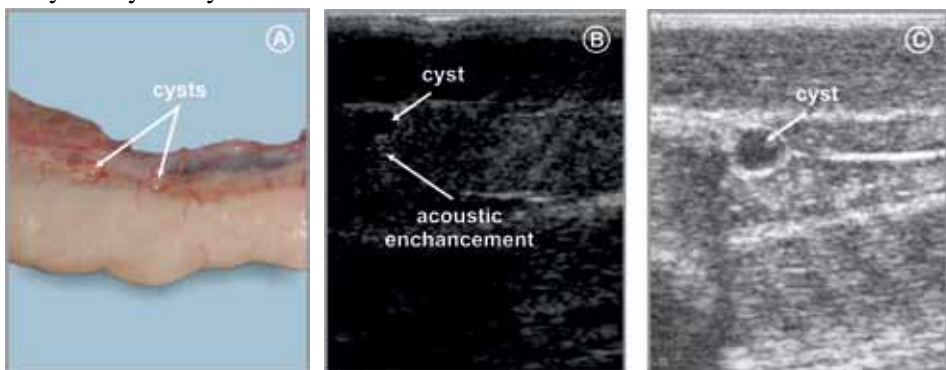
**Figure 184:** View of lobes of testis in Russian sturgeon. **A** – view of lobes of testis; **B** – frontal ultrasound image of lobes of testis.



#### 14.7.2 Cysts

A cyst is a pathological structure with tight walls and entirely filled with liquid. The cysts (2–4 mm in diameter) occur in the testicular tissue of sturgeons at different maturity stages (Figure 185). On the echogram, they appear as thick (walled) rounded anechoic structures with acoustic enhancement (see Figure 185A and B, below).

**Figure 185:** View of cyst in the sturgeon body cavity. **A** – dissected view of cysts in the Russian sturgeon testis; **B** – ultrasound image of the same testis (A) with distal acoustic enhancement; **C** – ultrasound image of cystic formation in the body cavity of 2-year-old sterlet female.



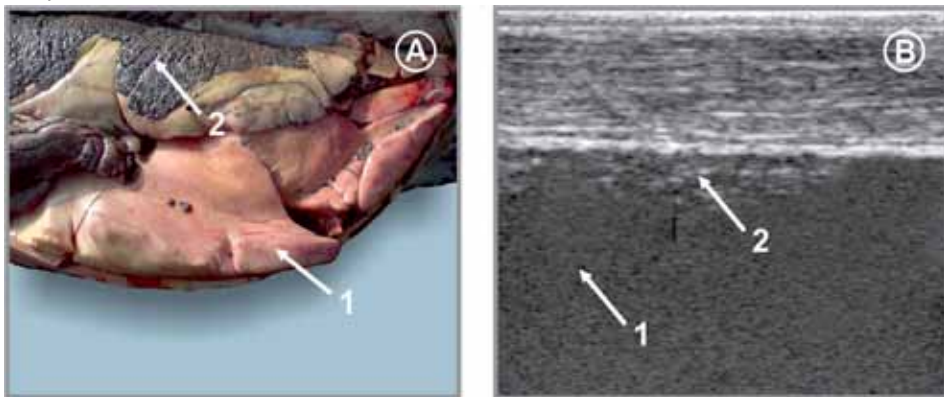
The cystic formations can be identified as organotypic tumors of the human lipoma and fibroma type, developing due to degeneration of ovigerous lamellae (Moiseeva, Fedorov and Parfenova, 1997). Such malformations in gonad development affect the reproductive performance of fish but do not hamper the normal development of gametes in the other portion of the gonad. Similar neoplasms can also be formed at development of tumors and granulomas.

### 14.7.3 Fatty degeneration of ovaries

Fatty degeneration of the ovaries is due to obesity of fish held in warmwater farms with year-round intensive feeding. In this case, single islets of ovarian tissue with a small quantity of mature oocytes are visible (Figure 186).

Obligatory temporal (two-month) holding of females at low water temperatures (4–6 °C), associated with feed deprivation is recommended to avoid obesity, especially when aiming at synchronization of gametogenesis in a majority of females (Chebanov and Savelyeva, 1999, Chebanov and Billard, 2001; Chebanov, Galich and Chmyr, 2004). This is of great importance for optimization of broodstock management and the control of reproduction in large sturgeon farms and hatcheries.

**Figure 186:** View of fatty gonads in a mature Siberian sturgeon female reared under conditions of constant high temperature (15–23 °C) and feeding (photo by E. Khachatryan) (A), and ultrasound image of frontal section of Siberian sturgeon ovary with fatty degeneration (B) (1 – fatty degeneration of an ovary; 2 – ripe oocytes).



### 14.7.4 Hermaphroditism

Hermaphroditism in sturgeons is encountered when ovaries and testes are located in one gonad (ovotestis). Specimens with one gonad represented by a testis and a second one by an ovary are rarely encountered.

As reported in Williot (2002) and Williot *et al.* (2005), hermaphroditism can reach up to 5 percent in one generation for sterlet (older than 14 years). Incidences of hermaphroditism of the same frequency are reported for other sturgeon species, both in aquaculture and for hatchery-produced brood fish in natural waterbodies (Romanov, Romanov and Belyaeva, 2001). It should be noted that due to this reason, in some cases sex determination by application of the ultrasound technique to one part of the gonad can lead to errors in separation of males from females in sturgeon farms.

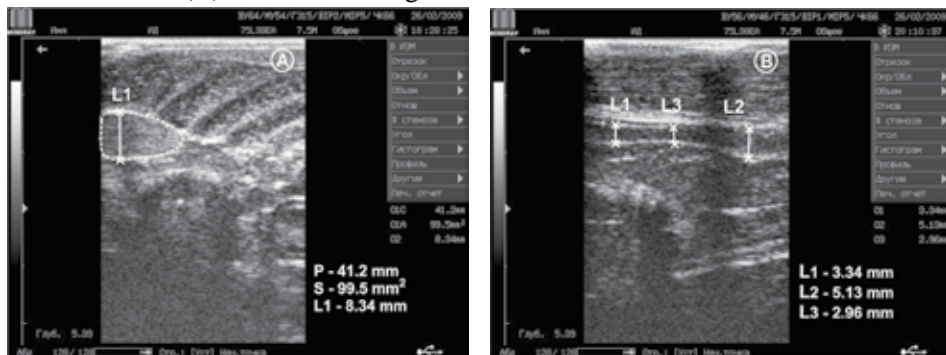


## 14.8 NONINVASIVE MEASUREMENTS OF LINEAR CHARACTERISTIC AND CALCULATION OF VOLUMETRIC PARAMETERS OF INNER ORGANS

Despite the effectiveness of gonadosomatic index (ratio gonad weight to fish weight), application in practice of domesticated broodstock establishment (Trusov, 1964; Doroshov, Moberg and Van Eenennaam, 1997), the necessity to sacrifice sturgeon for extraction and weighing of gonads is the prime disadvantage of the application of this index. It is obvious that such approach cannot be used for the development and implementation of better management practices (BMPs) for domesticated sturgeon broodstock, especially for rare and endangered species.

For this reason, during the formation and use of a live gene bank for sturgeon species (Chebanov *et al.*, 2002, 2006; Chebanov and Chmyr, 2002; Chebanov, Galich and Chmyr, 2004), it has been suggested to apply a new character – the ratio of gonad volume to total body volume. The latter can be easily calculated by immersion of live fish into a graduated vessel. Volumes of some gonads may be calculated on the basis of linear characters measurements using the noninvasive ultrasound express method (Figure 187). The standard procedure for automatic measurement of segments, angles, perimeters and surface areas (Figure 187) formed by closed circuits is typically presented in the manuals of different digital ultrasound diagnostic systems.

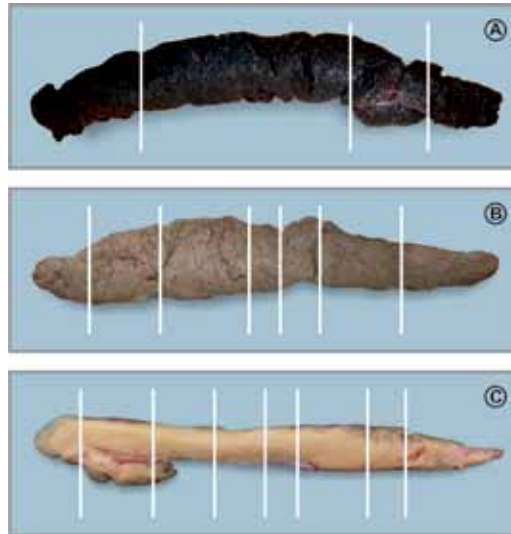
**Figure 187:** Examples of automatic measurement of segments (L1–L3), perimeters (P) and surface areas (S) formed by closed circuit on the frontal (A) and transverse (B) ultrasound images of testis.



Necessary measurements of linear sizes of gonads can be easily conducted (in the rectangular coordinate system) using “B” mode at frontal and transverse scanning.

The segmental division of the gonad into lobes (Figure 188) (dependent on shape changes) can be used to define its volume. This enables facilitation of the calculation of the total gonad volume by calculation of the volume of individual lobes (segments) using approximation by common geometric figures (e.g. ellipsoid of revolution, cylinder, truncated cone, etc.).

**Figure 188:** Segmental division of ovaries into lobes at different maturity stages. **A** – maturity stage IV; **B** – maturity stage III; **C** – maturity stage II.

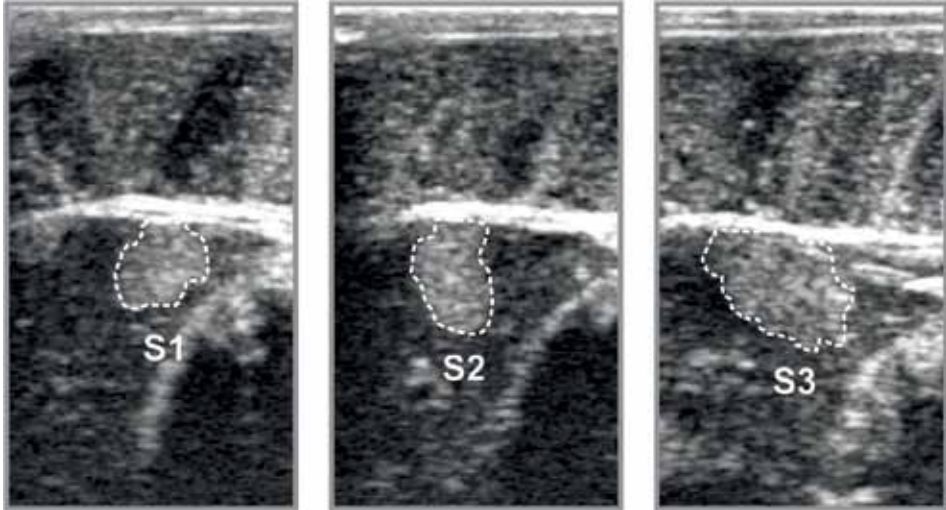


Automatic calculation of square areas of closed curves  $S_i$ , outlined on the ultrasound images by “control” transverse sections of single segments of gonads (Figure 189) and manual measurement of each segment length ( $L_i$ ) (between transverse sections) along the external fish surface allows source data for calculation of single segment volumes to be obtained (Figure 190).

**Figure 189:** Automatic measurement of surface areas ( $S_i$ ) of transverse sections on separate segments of testis on the ultrasound image.



**Figure 190:** Examples of transverse ultrasound images of separate segments of Russian sturgeon ovary for measurement of surface areas ( $S_1$ – $S_3$ ).



In this case, for calculation of the volumes of separate gonad segments ( $Vg$ ), it is wise to use the following formulae:

1. for segment shape close to a cylinder:  $Vg_i = S_i l_i$
2. for segment shape close to a truncated cone or pyramid:

$$Vg_i = \frac{1}{3} L_i (S_i + S_{i+1} + \sqrt{S_i S_{i+1}})$$

where,  $S_i$  = surface area of transverse section number “i” of the gonad;  $L_i$  = length of the gonad segment (lobe) number “i”; and  $S_{i+1}$  = surface area of transverse section number “i+1” of the gonad.

The accuracy of gonad volume calculation using these formulae will be defined by the number of segments (and vice versa), as well as by rate of longitudinal change in gonad shape.

To reduce uncertainty of measurements, a correcting coefficient may be used, which is calculated using a regression analysis of the calculated and true volumes of gonads in the course of control measurements for each sturgeon species.

The volumes of ovaries at maturity stage IV, calculated with the help of ultrasound and volumes of single mature (ripe) oocytes (on the basis of the diameters measured on the ultrasound images) (Figure 191) or using selected eggs allows forecasting of the absolute fecundity of females before collection of ovulated eggs.

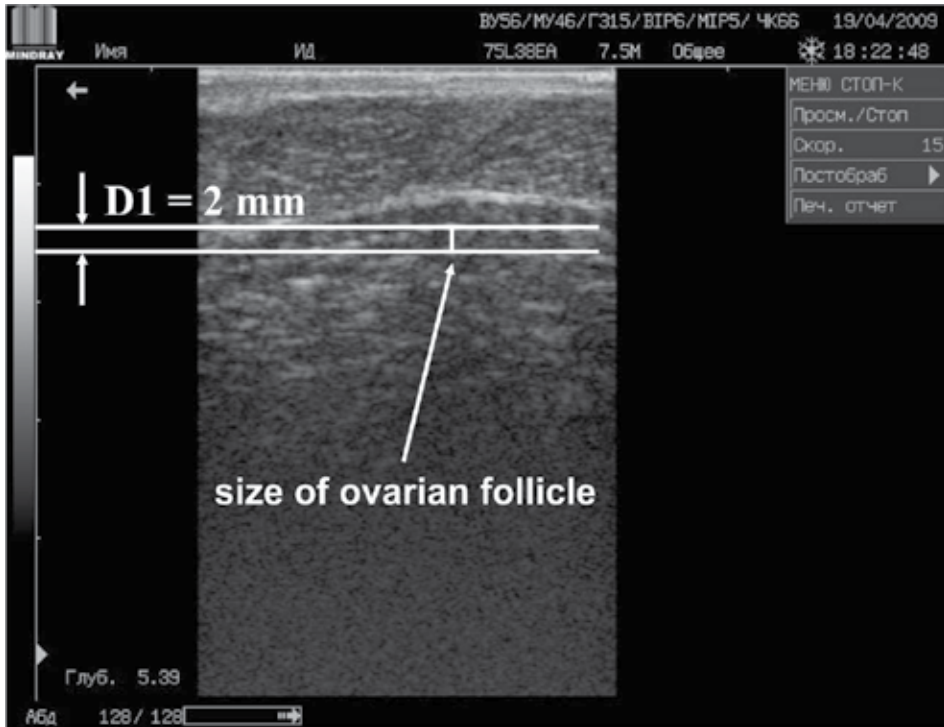
The volume of oocytes ( $V$ ) selected on the basis of biopsy can be calculated, for example, using the formula reported in Lenhardt *et al.* (2004), for Russian Danube sturgeon eggs:

$$V = \frac{4}{3} \times \pi \times \frac{D_1^2 D_2}{2}$$

where,  $D_1$  and  $D_2$  represent major and minor diameters of an egg, respectively.

Errors for similar measurements and in the calculation of gonad volumes in sturgeons would be decreased in the course of experience and by adaptation of the methods and standard calculation procedures used in medicine.

**Figure 191:** Measurement of an oocyte diameter ( $D_1$ ) on ultrasound image of frontal section of sterlet ovary.



In the near future, this method will allow the performance of noninvasive monitoring of the sex structure and the dynamics of gametogenesis in the course of fundamental studies aimed at evaluation of gynogenetic offspring of different sturgeon species (Badrtidinov *et al.*, 2008), dispermic androgenesis of endangered sturgeon species (Grunina *et al.*, 2009), evaluation of the impact of different factors on the development of gonad regulation (Wuertz *et al.*, 2005) and assist in the direction of other activities conducted with different sturgeon species at the living gene bank of the South Branch Federal Center of Selection and Genetics for Aquaculture.



## Annexes

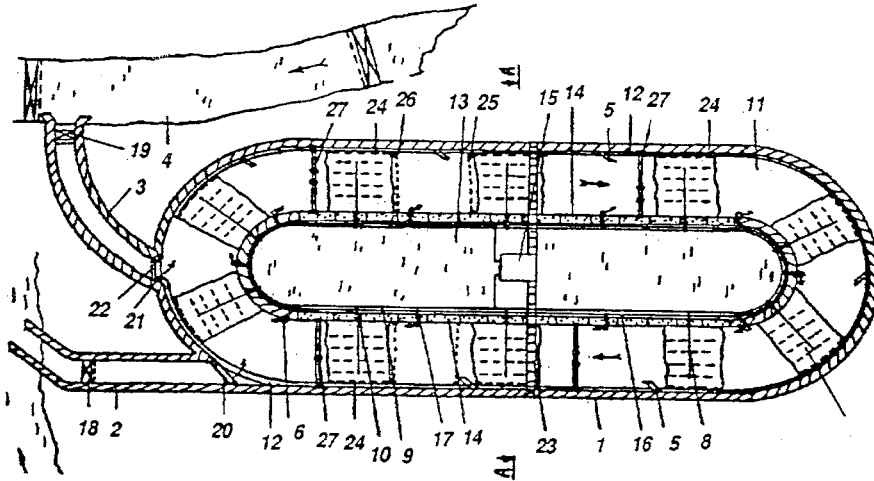
## Annex I

<i>English name<sup>1</sup></i>	<b>Species</b>
Siberian sturgeon	<i>Acipenser baerii</i>
Shortnose sturgeon	<i>Acipenser brevirostrum</i>
Yangtze sturgeon	<i>Acipenser dabryanus</i>
Lake sturgeon	<i>Acipenser fulvescens</i>
Russian (Danube) sturgeon	<i>Acipenser gueldenstaedtii</i>
Green sturgeon	<i>Acipenser medirostris</i>
Sakhalin sturgeon	<i>Acipenser mikadoi</i>
Adriatic sturgeon	<i>Acipenser naccarii</i>
Ship (Fringebarbel) sturgeon	<i>Acipenser nudiventris</i>
Atlantic sturgeon	<i>Acipenser oxyrinchus</i>
Persian sturgeon	<i>Acipenser persicus</i>
Sterlet sturgeon	<i>Acipenser ruthenus</i>
Amur sturgeon	<i>Acipenser schrenckii</i>
Chinese sturgeon	<i>Acipenser sinensis</i>
Stellate (Starry) sturgeon	<i>Acipenser stellatus</i>
Atlantic (Common) sturgeon	<i>Acipenser sturio</i>
White sturgeon	<i>Acipenser transmontanus</i>
Kaluga	<i>Huso dauricus</i>
Beluga (Beluga) sturgeon	<i>Huso huso</i>
Syr-Dar shovelnose (Syr Darya) sturgeon	<i>Pseudoscaphirhynchus fedtschenkoi</i>
Small Amu-Dar shovelnose (Dwarf) sturgeon	<i>Pseudoscaphirhynchus hermanni</i>
Large Amu-Dar shovelnose (Amu Darya) sturgeon	<i>Pseudoscaphirhynchus kaufmanni</i>
Pallid sturgeon	<i>Scaphirhynchus albus</i>
Shovelnose sturgeon	<i>Scaphirhynchus platyrhynchus</i>
Alabama sturgeon	<i>Scaphirhynchus suttkusi</i>
Paddlefish (Mississippi paddlefish)	<i>Polyodon spathula</i>
Chinese paddlefish (Chinese swordfish)	<i>Psephurus gladius</i>

<sup>1</sup> Rarely used names of sturgeon species that are recognized Fishbase common names (www.fishbase.org) are given in parentheses.

## DESIGN OF THE ARTIFICIAL SPAWNING CHANNEL FOR SEMINATURAL REPRODUCTION OF STURGEON

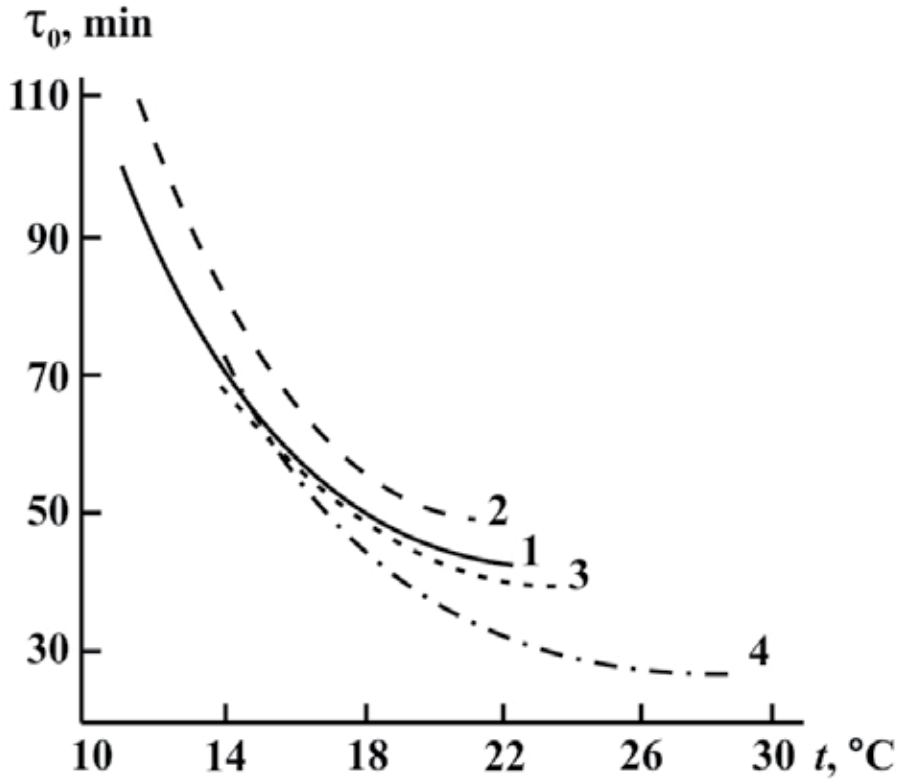
The channel has a controlled hydrological regime to create a swimming cycle route that imitates the spawning migration of brood fish (Chebanov, 1998).



- 1 – Circle spawning channel
- 2 – Channel for letting broodstock to pass and runoff
- 3 – Channel for juvenile runoff
- 4 – Waterbody for rearing of prelarvae
- 5 – Canopies for regulating current velocity
- 6 – Ejectors
- 7 – Spawning grounds
- 8 – Rinsing flute
- 9; 16 – Circle water pipelines
- 10; 17 – Turn off valves
- 11 – Pool
- 12 – Larval collection tray
- 13 – Internal waterbody
- 14 – Drainage filters
- 15 – Pump station
- 18, 19 – Sluice gates regulators
- 20, 21 – Protective meshes and turn-off dampers



- 22** – Removable large-sized fish protective net
- 23** – Crossing gangways
- 24** – Gauze screens
- 25** – Grooves for removable gauze blocking gratings
- 26** – Blocking gratings
- 27** – Mobile surface rinsing flutes

Relationship between  $\tau_0$  and temperature for four sturgeon species

1 – sterlet (*Acipenser ruthenus*), 2 – beluga (*Huso huso*), 3 – Russian sturgeon (*A. gueldenstaedtii*), 4 – stellate sturgeon (*A. stellatus*) (Dettlaff, 1961; Igumnova, 1975, 1985).

### Effective breeding number ( $N_E$ )

Effective breeding number ( $N_e$ ) of sturgeons (of one endangered subpopulation/ population) to be used in all propagation activities for supportive stocking (rehabilitation) or reintroduction when producing the progeny generation for one year-class (to achieve a generational effective population size  $N_{e(GEN)} = 100$  and an inbreeding rate/generation  $\Delta F \text{ max} = 0.50 \%$ ) (after ASMFC, 1996).

Species	Average age of first spawning females, years	Effective breeding number, $N_e$	$N_e$ / generation	No. females/No. males <sup>1</sup> captured in the same zone of rivers, recommended to be used per year for artificial spawning
Beluga sturgeon	14	100	7	4/3 3/4 5/2 2/5
Russian sturgeon	9	100	12	6/6 7/5 5/7
Stellate sturgeon	7	100	14	7/7 8/6 6/8
Ship sturgeon	12	100	8	4/4 3/5 5/3
Sterlet	5	100	20	10/10 11/9 9/11

<sup>1</sup> Sperm from multiple male donors should not be mixed for artificial fertilization.

Where:  $1/N_e = 1/(N_m) + 1/(N_f)$  and  $\Delta F = 1/(2 N_e) = 1/(8N_m) + 1/(8N_f)$

with  $N_m$  = number of males and  $N_f$  = number of females

$N_e/\text{generation} = \Delta (N_{e,1} + N_{e,2} + N_{e,3} + \dots + N_{e,GI})$ ,

where GI = generation interval



**LITERATURE CITED**

- Agh, N., Rosenthal, H., Sorgeloos, P & Motallebi, A.A.** (eds.) 2007. *Abstracts of the International Workshop on Advanced Techniques in Sturgeon Fish Larviculture*. March 12– 14, 2007, Urmia, Iran. Artemia and Aquatic Animal Research Institute, Urmia University, Urmia, Iran. 135 pp.
- Akhundov, M.M.** 1997. *The plasticity of gonadal sex differentiation of sturgeon*. Elm, Baku. 200 pp. (In Russian)
- Akhundov, M.M.** 1999. *The plasticity of gonadal sex differentiation of sturgeon (hormonal and ecological aspects)*. Avtoreferat Dissertatsii na Soiskaniye Uchenoi Stepeni Doktora Biologicheskikh Nauk. Baku, Institut Fisiologii AN Azerbaidjana. 45 pp. (In Russian)
- Akimova, N.V., Goryunova, V.B., Mikodina, E.V., Nikolskaya, M.P., Ruban, G.I., Sokolova, S.A., Shagayeva, V.G. & Shatunovsky, M.I.** 2004. *Atlas of abnormalities in gametogenesis and postembryonal morphology of sturgeons*. Moscow, Izdat'elsvo Vserossiiskii Nauchno-Issledovatel'skii Institut Rybnogo Khoyaistva i Okeanografii. 120 pp. (In Russian)
- Amiri, B.M., Maebayashi, M., Adachi, S. & Yamauchi, K.** 1996. Testicular development and serum sex steroid profiles during the annual sexual cycle of the male sturgeon hybrid, the bester. *Journal of Fish Biology*, 48: 1039–1050.
- Anonymous.** 1971. Preliminary guidelines for hatchery rearing of sturgeons in the Sea of Azov and the Don River basin. Moscow, MRH. 12 pp. (in Russian)
- Anonymous.** 1979. Guidelines on mineral fertilizers application in earthen fishponds at different soil and climate zones of the USSR. Moscow, VNIIPRKH. 35 pp. (In Russian)
- Anonymous.** 1986. Guidelines on artificial reproduction of sturgeons in the Caspian and Azov seas. Moscow, Izdat'elsvo VNIRO. 272 pp. (In Russian)
- Arlati, G., Bronzi, P., Colombo, L. & Giovannini, G.** 1988. Induced breeding of the Italian sturgeon (*Acipenser naccarii*) raised in captivity. *Rivista Italiana Acquacoltura*, 23: 94–96.
- Arthur, J.R., Bondad-Reantaso, M.G. & Subasinghe, R.P.** 2008. *Procedures for the quarantine of live aquatic animals: a manual*. FAO Fisheries Technical Paper No. 502. Rome, FAO. 74 pp.
- Artyukhin, E.N.** 1995. On biogeography and relationships within the genus *Acipenser*. *The Sturgeon Quarterly*, 3(2): 6–8.
- Artyukhin, E.N.** 2008. *Sturgeons (ecology, geographic distribution and phylogeny)*. St. Petersburg, Izdat'elsvo Sankt-Peterburgskii Gosudarstvennyi Universitet. 137 pp. (In Russian)

- Askerov, M.K. & Sidorov, P.A.** 1964. Biology and control of Phyllopora in sturgeon ponds. *Trudy AzCherNIRO*, 4: 83–97. (In Russian)
- ASMFC.** 1996. *Breeding and stocking protocol for cultured Atlantic sturgeon*. Final Report from the Atlantic Sturgeon Aquaculture and Stocking Committee to the Atlantic States Marine Fisheries Commission's Atlantic Sturgeon Management Board. Atlantic States Marine Fisheries Commission, Washington, DC. Special Report No. 68. 16 pp.
- Badenko, L.V., Dorosheva, N.G., Kornienko, G.G. & Chikhacheva, M.Zh.** 1984. *Ecological- physiological background of increasing the effectiveness of the Azov Sea sturgeon culture*. In: I.B. Bukhanevich, ed. *Reproduction of fish stocks in the Azov and Caspian seas*. Moscow, Izdat'el'svo Vserossiiskii Nauchno-Issledovatel'skii Institut Rybnogo Khoziaistva i Okeanografii. pp. 88–101. (In Russian)
- Badrtdinov, O.A., Kovalev, K.V., Lebedeva, E.B., Vasilyeva, E.D., Recoubratsky, A.V., Grunina, A.S., Chebanov, M.S. & Vasilyev, V.P.** 2008. Entirely male gynogenetic offspring of *Acipenser stellatus*. *Doklady Rossiiskoi Akademii Nauk*, 423(1): 120–123. (In Russian)
- Bahmani, M., Kazemi, R. & Hallajian, A.** 2005. *Workshop on sturgeon sexing and gonad staging*. 5th International Symposium on Sturgeon, May 9–13, Ramsar, Iran. 20 pp.
- Bams, R.A.** 1976. Survival and propensity for homing as affected by presence or absence of locally adapted paternal genes in two transplanted populations of pink salmon (*Oncorhynchus gorbusha*). *Journal of the Fisheries Research Board of Canada*, 33: 2716–2725.
- Barannikova, I.A.** 1970. New data about the response of sturgeon population on disturbance of the migration and reproduction conditions. *Trudy Tsentral'nyi Nauchno-Issledovatel'skii Institut Osetrovogo Rybnogo Khoziaistva*, 2: 12–19. (In Russian)
- Barannikova, I.A.** 1975. *Functional basis of fish migration*. Moscow, Izdatel'stvo "Nauka". 210 pp. (In Russian)
- Barannikova, I.A.** 1979. Present status and future problems of sturgeon culture. In I.A. Barannikova & L.S. Berdichevsky, eds. *Biological foundations of sturgeon culture development in the waterbodies of the USSR*. Moscow, Izdatel'stvo "Nauka". pp. 49–58. (In Russian)
- Barannikova, I.A., Bayunova, L.V. & Semenkova, T.B.** 2005. Serum sex steroids and their specific cytosol binding in the pituitary and gonads of Russian sturgeon (*Acipenser gueldenstaedtii* Brandt) during final maturation. *Journal of Applied Ichthyology*, 22: 331–333.
- Barannikova, I.A. & Boyev, A.A.** 1977. Methodical guidelines on application of a method of hypophysial injections in sturgeon culture. Moscow, Glavrybvod. 24 pp. (in Russian)

- Bartley, D.M., Gall, G.A.E. & Bentley, B.** 1985. Preliminary description of the genetic structure of white sturgeon, *Acipenser transmontanus*, in the Pacific Northwest. In F.P. Binkowsky & S.I. Doroshov, eds. *North American sturgeons: biology & aquaculture potential*, Dordrecht, Dr. Junk Publishers. pp. 105–109.
- Belyaeva, E.S.** 1983. On anomalies in development of sturgeon larvae. In: V.N. Belyaeva, ed. *Integral utilization of biological resources of the Caspian and Azov Seas*. Abstract of Conference of Young Scientists. Moscow, Izdatel'stvo VNIRO. pp. 12–13. (In Russian)
- Bemis, W., E. Findeis & L. Grande.** 1997. An overview of Acipenseriformes. *Environmental Biology of Fishes*, 48: 25-71.
- Bemis, W.E. & Kynard, B.** 1997 Sturgeon rivers: an introduction to Acipenseriformes biogeography and life history. In: *Sturgeon Biodiversity and Conservation* (eds V.J. Birstein, J.R. Waldman and W.E. Bemis). Kluwer Academic Publishers, Dordrecht, pp. 167–183.
- Berg, L.S.** 1948. *Fish of fresh waters of the USSR and adjacent countries*. Moscow, Izdatel'stvo Akademii Nauk SSSR. 468 pp. (In Russian)
- Bilio, M.** 2007. Controlled reproduction and domestication in aquaculture. *Aquaculture Europe*. 32(1): 5–14.
- Billard, R.** 2000. Biology and control of reproduction of sturgeons in fish farms. *Iranian Journal of Fisheries Science*, 2(2): 1–20.
- Billard, R.** (ed.) 2002. *Esturgeons et caviar*. Paris, Éditions Tec & Doc, Lavoisier. 298 pp.
- Billard, R., Cosson, J., Fierville, F., Brun, R., Rouault, T. & Williot, P.** 1999. Motility analysis and energetics of the Siberian sturgeon (*Acipenser baerii*) spermatozoa. *Journal of Applied Ichthyology*, 15: 199–203.
- Billard, R. & Lecointre, G.** 2002. Biology and conservation of sturgeon and paddlefish. *Reviews in Fish Biology and Fisheries*, 10: 355–392.
- Birstein, V.J., Doukakis, P. & DeSalle R.** 1999. Molecular phylogeny of Acipenserinae and black caviar species identification. *Journal of Applied Ichthyology*, 15 :12-16.
- Bogdanova, L.S.** 1972. Comparison of transition to exogenous feeding in Russian and Siberian sturgeon at different temperatures. *Trudy Tsentral'nyi Nauchno-Issledovatel'skii Institut Osetrovogo Rybnogo Khozyaistva*, 4: 217–223. (In Russian)
- Bogatova, I.B., Tagirova, N.A. & Ovchinnikova, V.V.** 1975. *Guidelines on commercial plankton culture in tanks for larvae and fry feeding*. Moscow, Izdatel'stvo VNIIPRKH. 50 pp. (In Russian)



- Bonpunt, E.** 2006. Sexage des sturgeons par echographie. *AquaFilia*, 12: 5–8
- Borodin, N.A.** 1897. A report about a summer 1895 zoological expedition on board of the cruiser Uralets in the northern part of the Caspian Sea. *Vestnik Rybopromyshlennosti*, 1: 1–31. (In Russian)
- Borzenko, M.P.** 1942. Caspian stellate sturgeon (systematics, biology and fisheries). *Izvestia Azerbajjankaya Nauchno-Issledovatel'skaya Stantsyya*, 7: 3–114. (In Russian)
- Boyko, N.E.** 2008. *Physiological mechanisms of adaptive functions at early ontogenesis of Russian sturgeon Acipenser gueldenstaedtii Brandt*. St. Peterburg, Avtoreferat Dissertatsii na Soiskaniye Uchenoi Stepeni Kandidata Biologicheskikh Nauk. 31 pp. (In Russian)
- Boyko, N.E. & Grigoryan, R.A.** 2002. Effect of thyroid hormones on the olfactory imprinting towards chemical stimuli in early ontogeny of Russian sturgeon *Acipenser gueldenstaedtii* Brandt. *Zhurnal Evolyutsionnoi Biokhimii i Fiziologii*, 38(2): 169–172. (In Russian)
- Boyko, N.E., Grigoryan, R.A. & Chikhachev, A.S.** 1993. Olfactory imprinting of *Acipenser gueldenstaedtii* fingerlings. *Zhurnal Evolyutsionnoi Biokhimii i Fiziologii*, 29(5–6): 509–514. (In Russian)
- Bruch, R.M., Dick, T.A. & Choudhury, A.** 2001. *A practical field guide for the identification of stages of lake sturgeon gonad development with notes on lake sturgeon reproductive biology and management implications*. Malone, WI, Published by Sturgeon for Tomorrow. 38 pp.
- Burlachenko, I.V. & Bychkova, L.I.** 2005. A method of clinical evaluation of sturgeon state in culture with recirculated system of water supply. *Rybnoye Khozyaistvo*, 6: 70–72. (In Russian)
- Burtsev, I.A.** 1969. *Methods for obtaining eggs from fish females*. Author's license 244793. Committee on Inventions and Discoveries, Council of Ministers of the USSR. (in Russian)
- Castelnaud, G., Rochard, E., Jatteau P. & Lepage, M.** 1991. Données actuelles sur la biologie d'*Acipenser sturio* dans l'estuaire de la Gironde. In P. Williot, ed., *Acipenser*. Bordeaux, Cemagref. pp. 251–275.
- Ceapa, C., Williot, P. & Bacalbasa-Dobrovici, N.** 2002. Present state and perspectives of stellate sturgeon brood fish in the Romanian part of the Danube. *International Review of Hydrobiology*. 87(5–6): 507–515.
- Chapman F.A. & Park, C.** 2005. Comparison of sutures used for wound closure in sturgeon following a gonad biopsy. *North American Journal of Aquaculture*, 67: 98–101.
- Chebanov, M.S.** 1996a. *Ecological basis of anadromous and semi-anadromous fish reproduction under conditions of regulated river flow (Kuban River example)*. Moscow, Avtoreferat Dissertatsii na Soiskaniye Uchenoi Stepeni Doktora Biologicheskikh Nauk. 47 pp. (In Russian)

- Chebanov, M.S.** 1996b. Ecological basis of optimization in sturgeon reproduction. *Rybovodstvo i Rybolovstvo*, 2: 9–12. (In Russian)
- Chebanov, M.S.** 1996c. Sturgeons in aquaculture: prospects of resource saving technologies. *Abstract of resource saving technologies in aquaculture*, Krasnodar. pp. 102–103. (In Russian)
- Chebanov, M.S.** 1997. Sturgeon culture in the Sea of Azov basin: problems and prospects of a new biotechnology. In H. Dunont, S. Wilson & B. Wazniewicz, eds. Caspian Environment Programme. *Proceedings from the First Bio-network Workshop*. Bordeaux, World Bank. pp. 29–42.
- Chebanov, M.S.** 1998. Conservation of sturgeon genetic diversity: enhancement and living gene bank. Action before extinction. *Proceedings of the International Conference on Conservation of Fish Genetic Diversity*. Vancouver, Benwell-Atkins Ltd. pp. 163–173.
- Chebanov, M.S.** 2005. Conservation culture of sturgeons in the Azov Sea basin. *1st International Workshop on the Biology, Conservation and Sustainable Development of Sturgeons in Southern Europe*. Fausto Munoz, Granada. pp. 69–73.
- Chebanov, M.S. & Billard, R.** 2001. The culture of sturgeons in Russia: production of juveniles for stocking and meat for human consumption. *Aquatic Living Resources*, 14: 375–381.
- Chebanov, M.S. & Chmyr, Yu.N.** 2002. New method of sturgeon culture optimization. *Rybovodstvo i Rybolovstvo*, 1: 20–21. (In Russian)
- Chebanov, M.S. & Galich, E.V.** 2008. Chinese sturgeon (*Acipenser sinensis* Gray): artificial reproduction and brood stock optimization by using ultrasound technique of sexing and gonad maturity staging. *Osetrovoe Khozyaistvo*, 2: 43–58. (In Russian)
- Chebanov, M.S. & Galich, E.V.** 2009. *Ultrasound diagnostics for sturgeon broodstock management*. FSGTSR, Krasnodar. Izdatel'stvo Prosvesheniye-Yug. 116 pp.
- Chebanov, M.S. & Galich, E.V.** 2010. *Ultrasound diagnostics of sturgeons*. FSGTSR, Krasnodar. Izdatel'stvo Prosvesheniye-Yug. 135 pp. (In Russian)
- Chebanov, M.S., Galich, E.V. & Ananyev, D.V.** 2008. Strategy for conservation of sturgeon under the conditions of the Kuban River flow regulation. *Special Publication of the World Sturgeon Conservation Society*, 2: 70–82
- Chebanov, M.S., Galich, E.V. & Chmyr, Yu.N.** 2004. *Sturgeon breeding and rearing handbook*. Moscow, "Rosinformagrotech". 136 pp. (In Russian)
- Chebanov, M.S., Galich E.V., & Merkulov Y.G.** 2008. Establishment and exploitation of sturgeon broodstocks at the South Branch Federal Center of Selection and Genetics for Aquaculture. In A.K. Bogeruk, ed. *Domesticated forms and breeds of sturgeons (Acipenseridae)*. Moscow, Ministry of Agriculture of the Russian Federation. pp. 52–85. (In Russian)

- Chebanov, M.S., Galich, E.V., Ostapenko, V.A. & Chmyr, Yu.N.** 2006. Production of sturgeon caviar: from experiments to acceleration of commercial production. *Rybovodstvo*, 3–4: 20–23. (In Russian)
- Chebanov, M.S., Karnaukhov, G.I., Galich, E.V. & Chmyr, Yu.N.** 2002. Hatchery stock enhancement and conservation of sturgeon, with an emphasis on the Azov Sea populations. *Journal of Applied Ichthyology*, 18: 463–469.
- Chebanov, M.S. & Savelyeva, E.A.** 1995. Sturgeon fisheries of the Azov-Kuban region; current state and prospects of development. In N.A. Dushkina, ed. *Abstracts of the International Symposium on Mariculture*. Moscow, Izdatel'stvo VNIRO. pp. 75–77. (In Russian)
- Chebanov, M.S. & Savelyeva, E.A.** 1996. *Biotechnology of sturgeon reproduction on the basis of polycyclic use of hatchery capacities under current ecological conditions*. Krasnodar, Izdatel'stvo KrasNIIRKH, 21 pp. (In Russian)
- Chebanov, M.S. & Savelyeva, E.A.** 1999. New strategies for broodstock management of sturgeon in the Sea of Azov basin in response to changes in patterns of spawning migration. *Journal of Applied Ichthyology*, 15(4–5): 183–190.
- Chebanov, M.S., Savelyeva, E.A., Galich, E.V. & Chmyr, Yu.N.** 1998. Ecological-biotechnological problems in sturgeon culture in the Sea of Azov basin. In M. Celikkate, I. Okumus, E. Duzgunes. & C. Mutlu, eds. *Proceedings of the First International Symposium on Fisheries & Ecology*. Trabzon, Fisheco. pp. 199–207.
- Chebanov, M.S., Savelyeva, E.A., Staroverov, N.A., Kolos, A.A. & Ponkrat'yeva (Galich), E.V.** 1991. *Methodology of long-term holding of Kuban River stellate sturgeon under controlled temperature regime*. Leningrad, GosNIIRKh. pp. 52–53. (In Russian)
- Chepurkina, M.A., Chepurkin, Yu.G., Golova, V.G., Semenova, I.N. & Solominova, N.P.** 2008. On the question of the effect of long-term transportation by live fish vessel on the survival and physiological state of Siberian sturgeon yearlings. *Osetrovoe Khozyaistvo*, 2: 27–40. (In Russian)
- Chikhachev, A.S.** 1996. Multiyear's monitoring of genetic structure of Azov sturgeon populations. *Abstracts of the First Russian Ichthyological Congress*. Moscow, Izdatel'stvo VNIRO. pp. 368–369. (In Russian)
- Chugunov, N.L. & Chugunova, N.I.** 1964. A biological and fishery comparison of the Sea of Azov sturgeons. *Trudy VNIRO*, 52: 87–182. (In Russian)
- Çiftci, Y., Üstündağ, C., Erteken, A., Özongun, M., Ceylan, B., Haşimoğlu, A., Güneş, E., Yoseda, K., Sakamoto, F., Nazaki, G. & Hara, S.** 2002. *Manual for the seed production of turbot, Psetta maxima in the Black Sea*. Special Publication No. 2, Central Fisheries Research Institute, Ministry of Agriculture and Rural Affairs, Trabzon, Turkey and Japan International Cooperation Agency. 80 pp.

- CITES Identification Guide – Sturgeon and Paddlefish.** 2001. Canadian Government Publishing. 165 pp.
- Clarke G.M.** 1995. Relationships between developmental stability and fitness – application for conservation biology. *Conservation Biology*, 9: 18–24.
- Conte, F.S., Doroshov, S.I., Lutes, P.B. & Strange, E.M.** 1988. *Hatchery manual for the white sturgeon Acipenser transmontanus Richardson with application to other North American Acipenseridae.* Oakland, University of California, Division of Agriculture and Natural Resources. 104 pp.
- Cosson, J., Lenhart, O., Mims, S.D., Shelton, W.L. & Rodina, M.** 2000. Analysis of motility parameter from paddlefish and shovelnose sturgeon spermatozoa. *Journal of Fish Biology*, 56: 1–20.
- Debus, L., Winkler, M. & Billard, R.** 2002. Structure of micropyle surface on oocytes and caviar grains in sturgeons. *International Review of Hydrobiology*, 87(5–6): 585–603.
- Dekhta V.A.** 1996. The use of the fluctuating asymmetry parameter as an index of the development stability. The main problems of fisheries and protection of waterbodies with fisheries in the Azov sea basin. Ed. Makarov E.V. Rostov-on-Don. “Poligraf”: 256–270. (in Russian)
- Dekhta V.A. & Tsvetnenko Yu.B.** 1996. Fluctuating asymmetry in natural populations of sturgeon and stellate surgeon in the Azov Sea. The main problems of fisheries and protection of waterbodies with fisheries in the Azov sea basin. Ed. Makarov E.V. Rostov-on-Don. “Poligraf”: 270–272. (in Russian)
- Deng, X., Van Eenennaam, J. & Doroshov, S.** 2002. Comparison of early life stages and growth of green and white sturgeon. In W. Van Winkle, P. Anders, D.H. Secor & D. Dixon, eds. *Biology, management, and protection of North American sturgeon.* American Fisheries Society Symposium 28, pp. 237–247.
- Derzhavin, A.N.** 1922. Stellate sturgeon. A biological essay. *Izvestiya Bakinskoi Ikhtiologicheskoi Laboratorii*, 1: 1–393. (In Russian)
- Dettlaff, T.A., Ginsburg, A.S. & Schmalhausen, O.I.** 1993. *Sturgeon fishes. Developmental biology and aquaculture.* Berlin, Springer-Verlag. 300 pp.
- Devedjian, K.** 1926. *Pêche et pêcheries en Turquie.* Constantinople. 127 pp.
- Devitsina, G.V. & Gadzhieva, A.R.** 1996. Dynamics of morphological development of the gustatory system in early ontogenesis of two sturgeon species – *Acipenser nudiiventris* and *A. persicus*. *Voprosy Ikhtiologii*, 36(5): 674–686. (In Russian)
- Di Lauro, M.N., Krise, W.F., Hendrix, V.F. & Baker, S.E.** 1994. Short-term cold storage of Atlantic sturgeon sperm. *Progressive Fish-Culturist*, 56: 143–144.

- Doroshov, S.I., Clark, W.H., Jr. Lutes, P.B., Swallow, R.L., Beer, K.E., McGuire, A.B. & Cochran, M.D.** 1983. Artificial propagation of the white sturgeon, *Acipenser transmontanus*. *Aquaculture*, 32: 93–104.
- Doroshov, S.I., Moberg, G.P. & Van Eenennaam, J.** 1997. Observations on the reproductive cycle of cultured white sturgeon, *Acipenser transmontanus*. *Environmental Biology of Fishes*, 48: 265–278.
- Dyubin, V.P. & Kiseleva, S.G.** 1983. Adaptation of sturgeon juveniles to sea water at various temperatures and different satiation. In: Barannikova I.A. & Verdichevskii L.S. eds. Biological basis of sturgeon culture, pp. 167–178. Moscow, Nauka. (In Russian)
- Edwards, D. & Doroshov, S.** 1989. *Appraisal of the sturgeon and sea trout fisheries and proposals for a rehabilitation programme*. Technical Cooperation Programme, TCP/TUR/8853. FAO. 38 pp.
- Eriksen, M.S., Espmark, A.M., Poppe, T., Braastad, B.O., Salte, R. & Bakken, M.** 2008. Fluctuating asymmetry in farmed Atlantic salmon (*Salmo salar*) juveniles: also a maternal matter. *Environmental Biology of Fishes*, 81: 87–99.
- FAO.** 2007. *Aquaculture development. 2. Health management for responsible movement of live aquatic animals*. FAO Technical Guidelines for Responsible Fisheries No. 5, Suppl. 2. Rome, FAO. 31 pp.
- FAO.** 2008a. *Aquaculture development. 5. Genetic resource management*. FAO Technical Guidelines for Responsible Fisheries No. 5, Suppl. 3. Rome, FAO. 125 pp.
- FAO.** 2008b. *Report of the EIFAC ad hoc working party on handling of fishes in fisheries and aquaculture*. Utrecht, Netherlands, 24–26 March 2004. EIFAC Occasional Paper No. 40. Rome, FAO. 88 pp.
- Fontana, F., Rossi, R., Lanfredi, M, Arlati, G. & Bronzi, P.** 1999. Chromosome banding in sturgeons. *Journal of Applied Ichthyology*. 15: 9-11.
- Galich, E.V.** 2000a. *Ecological and morphological peculiarities of the Kuban River sturgeons' early ontogenesis at seasonal control of their propagation*. Krasnodar, Avtoreferat Dissertatsii na Soiskaniye Uchenoi Stepeni Kandidata Biologicheskikh Nauk. 19 pp. (In Russian)
- Galich, E.V.** 2000b. Ecological and morphological peculiarities and neuropharmacological express testing of sturgeon juveniles reared in tanks. *Abstracts of the international conference "Sturgeons at the turn of the 21st Century"*. Astrakhan. pp. 227–229. (In Russian)
- Galich, E.V. & Chebanov, M.S.** 2004. Comparative evaluation of sturgeon larvae and juveniles reared under control of seasonal propagation of the wild and domestic breeders. *Journal of Fish Biology*, 65(Supplement): 329.

- Galich, E.V. & Chebanov, M.S.** 2009. Monitoring programme of fitness of sturgeon progeny, obtained from the farmed broodstock. *Abstract of the 6th International Symposium on Sturgeon. Harmonizing the relationships between human activities and nature: the case of sturgeon.* Wuhan, China. pp. 173–174.
- Gesner, J. Chebanov, M. & Freyhof, J.** 2009. *Huso huso*. In: IUCN 2010. *IUCN Red List of Threatened Species*. Version 2010.4. (available at: <http://www.iucnredlist.org/apps/redlist/details/10269/0>)
- Gerbilsky, N.L.** 1957. Ways of development of the intraspecific biological differentiation, type of anadromous migrants and the problem of migration impulse in sturgeons. *Uchenye Zapiski LGU*, 228(44): 11–32. (In Russian)
- Ginsburg, A.S.** 1968. *Fertilization in fishes and the problem of polyspermy*. Moscow, Izdatel'stvo "Nauka". 358 pp. (in Russian)
- Gisbert, E. & Williot, P.** 2002a. Influence of storage duration of ovulated eggs prior to fertilization on the early ontogenesis of sterlet (*Acipenser ruthenus*) and Siberian sturgeon (*Acipenser baerii*). *International Review of Hydrobiology*, 87: 605–612.
- Gisbert, E. & Williot, P.** 2002b. Advances in the larval rearing of Siberian sturgeon. *Journal of Fish Biology*, 60: 1071–1092.
- Gjerdrem, T.** (ed). 2005. Selection and breeding programs in aquaculture. Springer, Dordrecht. 364 pp
- Goddard, P.G.** 1995. *Veterinary ultrasonography*. Wallingford, CAB International. 297 pp.
- Golovanova, T.S., Klimonov, V.O., Dubov, V.E. & Nikonorov, S.I.** 2004. Effect of anesthetics of kainic group on fry and breeders of Russian sturgeon (*A. gueldenstaedtii*). *Sturgeon aquaculture: achievements and prospects for the development*, III International Science and Practical Conference. Astrakhan, BIOS. pp. 162–168. (In Russian)
- Golovin, P.P.** 2001. A gas regime related problem in aquaculture. *Rybnoe Khozyaistvo. Seria Bolezni Gidrobiontov v Akvakulture. VNIIPRKh*, 3: 15–23. (In Russian)
- Goncharov, B.F.** 1981. Appendix B: Duration of oocyte maturation time *in vitro* as a criterion for selecting sturgeon spawners for breeding In: T.A. Dettlaff, A.S. Ginsburg & O.I. Schmalhausen. *Razvitie osetrovyykh ryb*. Moscow, Izdatel'stvo "Nauka". 224 pp. (In Russian)
- Goncharov, B.F.** 1993. Appendix B: Duration of oocyte maturation time *in vitro* as a criterion for selecting sturgeon spawners for breeding In T.A. Dettlaff, A.S. Ginsburg, & O.I. Schmalhausen. *Sturgeon fishes. Developmental biology and aquaculture*. Berlin, Springer-Verlag. 300 pp.



- Goncharov, B.F.** 1998. *Hormonal regulation of late stages of oogenesis in Vertebrata (theoretical and practical aspects)*. Moscow, Institut Biologii Razvitiya RAN, Avtoreferat Dissertatsii na Soiskaniye Uchenoi Stepeni Doktora Biologicheskikh Nauk. 64 pp. (In Russian)
- Goncharov, B.F., Igumnova, L.V., Polupan, I.S. & Savelyeva, E.A.** 1991. A comparison of action of synthetic analogue of gonadotropin-releasing hormone, sturgeon pituitaries on maturation in sturgeon fishes. *Ontogenez*, 22(5): 514–524. (In Russian)
- Goncharov, B.F., Skoblina, M.N., Trubnikova, O.B. & Chebanov, M.S.** 2009. Influence of temperature on the sterlet (*Acipenser ruthenus* L.) ovarian follicles state. *Biology, conservation and sustainable development of sturgeons. Fish & Fisheries Series*, Berlin, Springer-Verlag. 29: 205–214.
- Gorbacheva, L.T.** 1977. On increasing the efficiency of sturgeon hatchery operation of the Don River. *Trudy VNIRO. V. CXXVII A. Vospriizvodstvo ryb Azovskogo i Kaspiiskogo moryei*. pp. 124–131. (In Russian)
- Goryunova, V.B., Shagaeva, V.G. & Nikol'skaya, M.P.** 2000. Analysis of anomalies in the structure of larval and young Acipenseridae in the Volga-Caspian basin under artificial reproduction. *Voprosy Ikhtiologii*, 40(6): 804–809. (In Russian)
- Grunina, A.S., Recoubratsky, A.V., Barmintsev, V.A., Tsvetkova, L.I. & Chebanov, M.S.** 2009. Dispermic androgenesis as a method of recovering endangered sturgeon species. *Biology, conservation and sustainable development of sturgeons. Fish & Fisheries Series*, 29(2): 187–204.
- Gruslova, A.B. & Trenkler, I.V.** 2001. Prospects of repeated use of Russian sturgeon males (*A. gueldenstaedtii* Br.) for hatchery. *Abstracts of "Sturgeon aquaculture: achievements and prospects for the development"*. II International Science and Practice Conference, Astrakhan. pp. 22–23. (In Russian)
- Gurtovoy, N.N., Matveev, B.S. & Dzerjinskiy, F.Y.** 1976. *Practical zootomy of vertebrates*. Moscow, Vysshya Shkola. 351 pp. (In Russian)
- Hafezieh, M., Kamarudin, M.S., Saad, C.R.B., Sattar, M.K.A., Agh, N. & Hosseinpour, H.** 2009. Effect of enriched *Artemia urmiana* on growth, survival and composition of larval Persian sturgeon. *Turkish Journal of Fisheries and Aquatic Sciences*, 9: 201–207.
- Hedrick, R.P. & LaPatra, S.E.** 2001. Characteristics of viral diseases of sturgeon and their impact on aquaculture, conservation, and international trade. Abstract. 4<sup>th</sup> International Symposium on Sturgeon, Oshkosh, Wisconsin, July 8–13, 2001.
- Hochleithner, M. & Gessner, I.** 1999. *The sturgeons and paddlefishes of the world: biology and aquaculture*. Kitzbuehel, Aquatech. 165 pp.



- Hurvitz, A., Degani, G., Goldberg, D., Din, S.Y., Jackson, K. & Levavi-Sivan, B.** 2005. Cloning of FSH $\beta$ , LH $\beta$ , and glycoprotein  $\alpha$  subunits from the Russian sturgeon (*Acipenser gueldenstaedtii*),  $\beta$ -subunit mRNA expression, gonad development, and steroid levels in immature fish. *General and Comparative Endocrinology*, 140: 61–73.
- Igumnova, L.V.** 1975. *Recommendations on biotechnique of hatchery breeding of beluga*. Moscow, Glavrybvod. 27 pp. (In Russian)
- Jafaryan, H., Alimohamady, A. & Makhodomi, N.** 2009. The use of enriched *Daphnia magna* by probiotic yeast on promotion of feeding efficiency of Persian sturgeon larvae. *Abstracts of the 6th International Symposium on Sturgeon. Harmonizing the relationships between human activities and nature: the case of sturgeon*. Wuhan, China. pp. 251–253.
- Jafaryan, H., Makhodomi, N. & Pordelan, A.** 2009. The effect of bioencapsulated *Artemia urmiana* using probiotic bacillus to enhance growth performance in *Acipenser nudiventris* larvae. *Abstracts of the 6th International Symposium on Sturgeon. Harmonizing the relationships between human activities and nature: the case of sturgeon*. Wuhan, China. pp. 150–151.
- Kaczmarczyk, D., Luczynski, M. & Kolman, R.** 2008. Assemblage of spawning pairs of farmed American paddlefish based on their individual genetic profiles – a new tool in managing of the broodstock’s gene pool. Summary Document of Aquaculture Europe 2008. pp. 36–37.
- Karlsen, O. & Hol, J.C.** 1994. Ultrasonography, a non-invasive method for sex determination in cod (*Gadus morhua*). *Journal of Fish Biology*, 44: 965–971.
- Kasimov, R.Yu.** 1980. *Comparative characteristic of wild and hatchery bred sturgeon fingerlings at early ontogenesis*. Elm, Baku. 136 pp. (In Russian)
- Kasimov, R.Yu.** 1987. *Ecological and physiological peculiarities of development of valuable and commercial fish in Azerbaijan*. Elm, Baku. 171 pp. (In Russian)
- Kasumyan, A. & Døving, K.B.** 2003. Taste preferences in fish. *Fish and Fisheries*, 4(4): 289 – 347.
- Kazakov, R.V. & Titov, S.V.** 1998. Populational and genetic organization of *Salmo salar* L. in Atlantic sturgeon. In R.V. Kazakov, ed. St. Petersburg, “Nauka”. pp. 43–72. (In Russian)
- Kazansky, B.N.** 1975. Peculiarities of gametogenesis and ecological plasticity of fish cycles and reproductions. In I.A. Barannikova, ed. *Ecological plasticity of fish cycles and reproduction*. Leningrad. Izdatel’stvo Leningradskii Gosudarstvennyi Universitet. pp. 3–32. (In Russian)
- Kazansky, B.N., Feklov, Yu.A., Podushka, S.B. & Molodtsov, A.N.** 1978. Express method of gonad maturity stage determination in sturgeon breeders. *Rybnoe Khozyaistvo*, 2: 24–27. (In Russian)

- Kazansky, B.N. & Molodtsov, A.N.** 1974. *Recommendations for handling sturgeon spawners, migrants of different types, according to continuous regime in production lines with regulated water temperature.* Moscow, GlavRybVod. 59 pp. (In Russian)
- Kazarnikova, A.V. & Shestakovskaya, E.V.** 2005. *Main sturgeon diseases in aquaculture.* Moscow, Izdat'elstvo Vserossiiskii Nauchno-Issledovatel'skii Institut Rybnogo Khozaistva i Okeanografii. 104 pp. (In Russian)
- Khodorevskaya, R.P., Ruban, G.I. & Pavlov, D.S.** 2009. *Behaviour, migration, distribution and stock abundance of sturgeons in the Volga-Caspian basin.* Moscow, Izdatel'stvo KMK. 242 pp. (In Russian)
- Kokoza, A.A.** 2004. *Artificial reproduction of sturgeon fishes.* Astrakhan, Izdatel'stvo AGTU. 208 pp. (In Russian)
- Kolman, R.** 2006. *Jesiotry chów i hodowla – Poradnik hodowcy.* Olsztyn, Wydawnictwo IRS. 117 pp.
- Konstantinov, A.S., Zdanovich, V.V., Pushkar, V.I., Rechinskiy, V.V. & Kostoeva, T.N.** 2005. Growth and energetics of sterlet fry under optimal stationary thermal regime and at swimming in thermal gradient space depending on fish satiation. *Voprosy Ikhtiologii*, 45(6): 831–836. (In Russian)
- Korzhuev, P.A., Nikolskaya, I.S. & Rodzieskaya L.I.** 1960. Respiration of sturgeon eggs during the period of incubation. *Voprosy Ikhtiologii*, 14: 113–118. (In Russian)
- Kouřil, J., Chamačková, J., Stupka, Z., Mikodina, E.V., Sedova, M.A. & Vachta, R.** 2004. Influence of temperature on stellate sturgeon (*Acipenser stellatus*) sensitivity to anesthetic effect of clove oil. *Sturgeon aquaculture: achievements and prospects for the development*, III International Science and Practical Conference. Astrakhan, BIOS. pp. 184–186. (In Russian)
- Kozlov, A.B., Nikonorov, S.I. & Vitvitskaya, L.V.** 1989. Formation of adaptive responses in stellate sturgeon fry at rearing under different environmental conditions. *Sturgeon fisheries in the USSR waterbodies.* Abstracts of the All-Union Conference, November 1989. Astrakhan, Izdatel'stvo KaspNIIRKH. pp. 147–148. (In Russian)
- Krasnodembskaya, K.D.** 1994. *Methodological guidelines on evaluation of physiological fitness of sturgeon and bony fish larvae reared in hatcheries, on the basis of reaction of pigment cells (melanophores).* St. Peterburg, GlavRybVod. 39 pp. (In Russian)
- Krayushkina, L.S.** 1983. Functional fitness of the osmoregulation system of sturgeon fry depending on size and age. In I.A. Barnnikova & L.S. Berdichevsky, eds. *Biological basis of sturgeon culture.* Moscow, Izdatel'stvo "Nauka". pp. 158–166. (In Russian)

- Krayushkina, L.S.** 2006. Considerations on evolutionary mechanisms of osmotic and ionic regulation in Acipenseridae: an overview. *Journal of Applied Ichthyology*, 22(1): 70–76.
- Krupiy, V.A., Grigoryeva, T.N. & Otpushchenikova, V.L.** 2005. Results of catchability coefficient of assessment trawl for sturgeon fry of higher than standard weight. *In* M.I.
- Karpyuk, ed. *Fishery studies in the Caspian Sea. Results of R&D year 2004*. Astrakhan, Izdatel'stvo KaspNIIRKh. pp. 575–579. (In Russian)
- Krupiy, V.A. & Kolodkova, L.G.** 1996. Dynamics of food base development in grow-out ponds and its effect on the diet and survival of Russian sturgeon fry. *In* L.A. Dushkina, ed. *Status and prospects of scientific and practical implementations in Russian mariculture*. Rostov-on-Don, Izdat'el'svo VNIRO. pp. 142–153. (In Russian)
- Kuftina, N.D., Zaitseva, I.I. & Novikov, G.G.** 1984. Effect of temperature on some morpho-physiological parameters of lumpfish (*Cyclopterus lumpus* L.) eggs during embryonic development. *In* M.I. Shatunovsky, ed. *Biological fundamentals of fishery. Actual problems of environmental physiology and biological chemistry of fish*. Moscow, Izdatel'stvo "Nauka". pp. 66–84. (In Russian)
- Kukuradze, A.M., Kirilyuk, M.M. & Salnikov, N.E.** 1975. Characteristic of gonad states in sturgeon females in the northwestern part of the Black Sea under conditions of regulated river flow. *Trudy VNIRO*, 112–130. (In Russian)
- Kupinskiy, S.B. & Yanchenko, Yu. K.** 2001. Calculation of sturgeon larval stocking density in trays at rearing. *Rybolovstvo & Rybovodstvo*, 1: 67–68. (In Russian)
- Kushnarenko, A.I.** 1971. On the question of qualitative assessment of artificially reared sturgeon fry. *Trudy Tsentral'nyi Nauchno-Issledovatel'skii Institut Osetrovogo Rybnogo Khozyaistva*, 3: 168–174. (In Russian)
- Kuzina, V.F.** 2005. *Methods of chromosome aberration count. Physiological and biochemical and genetic investigations of ichthyofauna in the Azov and Black sea basins*. *In* V.V. Voinova, ed. *Guidelines*. Rostov-on-Don, Everest. pp. 56–59. (In Russian)
- Kynard, B. & Kieffer, M.** 2002. Use of a borescope to determine the sex and egg maturity stage of sturgeons and the effect of borescope use on reproductive structures. *Journal of Applied Ichthyology*, 18: 505–508.
- Labenets, A.V. & Nikiforov, A.I.** 1999. Positive experience of Californian worms in young Russian sturgeon breeding. *In: Materials of the reports. 2nd International Symposium "Resource-sparing technologies in aquaculture"*. Krasnodar, Zdravstvuite. pp. 204–205. (In Russian)

- Lajus D.L., Graham J.H. & Kozhara A.V.** 2003. Developmental instability and the stochastic component of total phenotypic variance. M. Polak, ed. *Developmental instability: causes and consequences*. Oxford, Oxford University Press. pp. 343–363.
- Lajus D. L., Graham J. H., Katolikova M. V. Yurtseva A. O.** 2009 Fluctuating asymmetry and random phenotypic variation: history, achievements, problems, perspectives. *Vestnik Sankt-Peterburgskogo Universiteta. Seriya Biologiya*, **3**: 98–110. (In Russian).
- Lavens, P. & Sorgeloos, P.** (eds.) 1996. *Manual on the production and use of live food for aquaculture*. FAO Fisheries Technical Paper No. 361. Rome, FAO. 295 pp.
- Lemberget, T. & McCormick, M.** 2009. Replenishment success linked to fluctuating asymmetry in larval fish. *Oecologia*, **159**: 83–93.
- Lenhardt, M., Finn, R.N., Cakic, P., Kolarevic, J., Krpo-Cetkovic, J., Radovic, I. & Fyhn, H.J.** 2004. Analysis of the post-vitellogenic oocytes of the three species of Danubian Acipenseridae. *Belgian Journal of Zoology*, **134**(Suppl. 1): 77–79.
- Lens, L., Van Dongen, S., Kark, S. & Matthysen, E.** 2002. Fluctuating asymmetry as an indicator of fitness: can we bridge the gap between studies. *Biological Reviews*, **77**: 27–38.
- Leung, B., Forbes, M.R. & Houle, D.** 2000. Fluctuating asymmetry as a bioindicator of stress: Comparing efficacy of analyses involving multiple traits. *American Naturalist*, **155**: 101–115.
- Levin, A.V.** 1989. Some peculiarities of Volgo-Caspian sturgeon fry behaviour. In D.S. Pavlov & Yu.N. Sbikin, eds. *Morphology, ecology and sturgeon behavior*. Moscow, Izdatel'stvo "Nauka". pp. 141–151. (In Russian)
- Litvinenko, L.I. Mamontov, Yu.P., Ivanova, O.V., Litvinenko, A.I. & Chebanov, M.S.** 2000. *Guidelines on Artemia application in aquaculture*. Tyumen, SibRybNIIproekt. 58 pp. (In Russian)
- Lu, X., Webb, M., Talbott, M., Van Eenennaam, J., Palumbo, A., Lunares-Casensve, J., Doroshov, S., Struffenegger, P. & Rasco, B.** 2010. Distinguishing ovarian maturity of farmed white sturgeon (*Acipenser transmontanus*) by Fourier transform infrared spectroscopy: a potential tool for caviar production management. *Journal of Agricultural and Food Chemistry*, **58**(7): 4056–4064.
- Lukyanenko, V.I., Kasimov, R.Yu. & Kokoza, A.A.** 1984. *Age-weight standard of hatchery Caspian sturgeon fingerlings*. Volgograd, Institut Biologii Vnutrennikh Vod AN SSR. 226 pp. (In Russian)
- Lyon, E.P.** 1905. Rheotropism in fishes. *Biological Bulletin*, **8**: 39–63.

- Mailyan, R.A.** 1971. Manual on commercial rearing of fish fingerlings of Azerbaijan. (sturgeon, salmon, ordinary fish). Baku. Azerbaijan Branch of TSNIORH. 62 pp. (in Russian).
- Makarov, E.V.** 1970. Assessment of dynamics and structure of Azov Sea sturgeon stocks. *Trudy VNIRO*, 71: 96–115. (In Russian)
- Maltsev, A.V. & Merkulov, Y.G.** 2006. Biometric method for sex identification in sturgeons, in particular the Russian sturgeon *Acipenser gueldenstaedtii* (Acipenseridae) of the Azov population. *Voprosy Ikhtiologii*, 46(4): 536–540. (In Russian)
- Mamedov, Ch.A.** 2000. New technology for the extermination of saprolegniosis during the embryonic stage in sturgeon. In V.P. Ivanov, ed. *Sturgeons at the turn of XXI century*. Astrakhan, Izdatel'stvo KaspNIIRKH. pp. 262–263. (In Russian)
- Marti, V.Yu.** 1940. Systematics and biology of the Russian sturgeon from the Caucasian shore of the Black Sea. *Zoologicheskii Zhurnal*, 19: 865–872. (In Russian)
- Matishov, G.G., Ponomarev, S.V. & Ponomareva, E.N.** 2007. Innovation technologies of industrial aquaculture in sturgeon breeding. In S.V. Ponomarev, ed. Rostov-on-Don, Izdatel'stvo Yuzhnyi Naychnyi Tsent Rossiiskaya Akademiya Nauk. 368 pp. (In Russian)
- Mattson, N.S.** 1991. A new method to determine sex and gonad size in live fishes by using ultrasonography. *Journal of Fish Biology*, 39: 673–677.
- Memiş, D.** 2007. Sturgeon aquaculture. In A. Candan, S. Karataş, Küçüktaş & L. Okumuş, eds. *Marine aquaculture in Turkey*. Istanbul, Turkish Marine Research Foundation. pp. 49–59.
- Memiş, D., Çelikkalel, M.S. & Ercan, E.** 2004. The effect of different diets on the white worm (*Enchytraeus albidus* Henle, 1837) reproduction. *Turkish Journal of Fisheries and Aquatic Sciences*. 4: 5–7.
- Memiş D., Ercan, E., Yamaner, G.** 2011. Acclimation to farm conditions of wild caught sturgeon species as by-catch from the North-West Turkish Black Sea costs. *Journal of Applied Ichthyology*. 27:433-435.
- Milshtein, V.V.** 1982. *Sturgeon culture*. Moscow, PishcheProm. 151 pp. (In Russian)
- Mims, S.D., Lazur, A., Shelton, W.L., Gomelsky, B. & Chapman, F.** 2002. *Species profile. Production of sturgeon*. SRAC Publication No. 7200. Southern Regional Aquaculture Center, Stoneville, MS. 8 pp.
- Mironov, S.G.** 1994. *Adaptation of some carp and sturgeon species to chemical background of starter feeds (behavioural and farming aspects)*. Avtoreferat Dissertatsii na Soiskaniye Uchenoi Stepeni Kandidata Biologicheskikh Nauk. Kaliningrad, Kaliningradskii Gosudarstvennyi Tehnicheskii Universitet. 24 pp. (In Russian)

- Moghim, M., Vajhi, A.R., Veshkin, I.A. & Masoudifard, M.** 2002. Determination of sex and maturity in *Acipenser stellatus* by using ultrasonography. *Journal of Applied Ichthyology*, 18: 325–328.
- Mohler, J.W.** 2003. *Culture manual for the Atlantic sturgeon*. *Acipenser oxyrinchus oxyrinchus*. Hadley, MA, Region 5 United States Fish & Wildlife Service Publication. 68 pp.
- Moiseeva, E.B., Fedorov, S.I. & Parfenova, N.A.** 1997. Abnormalities of Azov Sea sturgeon (*Acipenseridae*) females gonad formation. *Voprosy Ikhtiologii*, 37(5): 660–666. (In Russian)
- Mugue, N.S. & Barmintseva, A.E.** 2009. Development of mitochondrial and nuclear markers for sturgeon species identification, genetic management in aquaculture, and in the restocking programs. *Abstract of the 6th International Symposium on Sturgeon. Harmonizing the relationships between human activities and nature: the case of sturgeon*. Wuhan, China. pp. 85–86.
- Mugue, N.S., Barmintseva, A.E., Rastorguev, S.M., Mugue, V.N. & Barmintsev, V.A.** 2008. Polymorphism of the mitochondrial DNA control region in eight sturgeon species and development of a system for DNA-based species identification. *Russian Journal of Genetics*, 44(7): 793–798.
- Nekrasova, S.O.** 2006. *Enhancement of efficiency of stellate sturgeon (Acipenser stellatus Pallas) and paddlefish (Polyodon spathula Walbaum) rearing on the basis of peculiarities of their behaviour in early ontogenesis*. Avtoreferat Dissertatsii na Soiskaniye Uchenoi Stepeni Kandidata Biologicheskikh. Astrakhan. 24 pp. (In Russian)
- Nikonorov, S.I. & Vitvitskaya, L.V.** 1993. *Ecological and genetic problems of artificial reproduction of sturgeon and salmon*. Moscow, Izdatel'stvo "Nauka". 254 pp. (In Russian)
- Ninua, N. Sh.** 1976. *Atlantic sturgeon of the Rioni River*. Metsniereba. 122 pp. (In Russian)
- Nocillado, J.N., Van Eenennaam, J.P. & Doroshov, S.I.** 1999. Final ovarian maturation and egg quality in hormonally-induced white sturgeon (*Acipenser transmontanus*). *Journal of Applied Ichthyology*, 15: 319.
- Noori, F., Azari Takami, G. & Sorgeloos, P.** 2002. Enrichment of *Artemia* with essential fatty acids, lipid emulsions and vitamin C and its effect on the performance of *Acipenser persicus* larvae under the effect of salinity stress. Abstracts Aquaculture, 5th International Symposium on Sturgeon, May 9–13, Ramsar, Iran. pp. 54–55.
- Orlov, G.I. & Garanov, V.I.** 1977. Mechanization of production process at incubation of sturgeon eggs. *Rybnoe Khozyaistvo*, 3: 32–33. (In Russian)
- Orlov, Yu.I., Krujalina, E.I., Averina, I.A. & Ilyicheva, T.I.** 1974. *Live fish transportation in waterproof hauling containers*. Moscow, PishcheProm. 20 pp. (In Russian)



- Ortenburger, A.I., Jansen, M.E. & Whyte, S.K.** 1996. Nonsurgical videolaparoscopy for determination of reproductive status of the arctic charr. *Canadian Veterinary Journal*, 37: 96–100.
- Palmer, A.R. & Strobeck, C.** 2003. Fluctuating asymmetry analyses revisited. In M. Polak, ed. *Developmental instability: causes and consequences*. New York, Oxford University Press. pp. 279–319.
- Palmer, P.E.S., Breyer, B., Bruguera, C.A., Gharbi, H.A., Goldberg, B.B., Tan, F.E.H., Wachira, M.W. & Weill, F.S.** 1995. *Manual on diagnostic ultrasound*. Geneva, World Health Organization. 334 pp.
- Parauka, F.M.** 1993. *Guidelines for artificially spawning gulf sturgeon (Acipenser oxyrinchus desotoi)*. Panama City, FL, United States Fish & Wildlife Service. 33 pp.
- Pavlov, D.S.** 1966. Patterns of semianadromous fish migration. *Voprosy Ikhtiologii*, 6(3): 528–539. (In Russian)
- Pavlov, D.A.** 2006. A method for the assessment of sperm quality in fish. *Voprosy Ikhtiologii*, 46(3): 384–392. (In Russian)
- Pavlov, D.S. & Saburenkov, E.N.** 1974. Velocities and patterns of fish movement. In *Basic characteristics of fish behavior and orientation*. Moscow, Izdatel'stvo "Nauka". pp. 155–187. (In Russian)
- Persov, G.M.** 1941. An account of sturgeon culture work with reference to the use of the method of pituitary injections. In N.L. Gerbil'sky, ed. *The method of pituitary injections and its role in reproduction of fish resources*. Leningrad, Izdatel'stvo LGU. pp. 42–50. (In Russian)
- Persov, G.M.** 1975. *Sex differentiation of fish*. Leningrad, Leningradskii Gosudarstvenyi Universitet. 148 pp. (In Russian)
- Petrova, T.G.** 1978. *Preliminary recommendations on biotechnology of bester culture in cages and tanks with the use of warm water*. Moscow, Vserossiiskii Nauchno-Issledovatel'skii Institut Rybnogo Khoziaistva i Okeanografii. 9 pp. (In Russian)
- Petrova, T.G., Krivtsov, V.F., Kozovkova, N.A., Kushnirova, S.A., Melchenkov, E.A. & Vinogradov, V.K.** 2001. Methods of sterlet broodstock establishment. In: Bagrov A.M. ed. *Collection of scientific-technological and methodical documentation of Aquaculture*. Moscow, VNIRO. pp.212–221. (In Russian)
- Plokhinsky, N.A.** 1970. *Biometry*. Moscow, Izdatel'stvo Moskovskogo Gosudarstvennogo Universiteta. 362 pp. (In Russian)
- Podushka, S.B.** 1986. Methods of egg obtaining in sturgeon with life preservation. Author's license 141035. Methods for obtaining eggs from fish females. Committee on Inventions and Discoveries, Council of Ministers of the USSR. (In Russian)



- Podushka, S.B.** 1999. New method to obtain sturgeon eggs. *Journal of Applied Ichthyology*, 15(4–5): 319.
- Podushka, S.B.** 2003. On the systematics of Russian sturgeon from the Azov Sea. *Nauchno- Tehnicheskii Byulleten Laboratorii Ikhtiologii INENKO*, 7: 19–44. (In Russian)
- Podushka, S.B.** 2008a. On the question of micropyle count in ship eggs. *Osetrovoe Khozyaistvo*, 2: 82–87. (In Russian)
- Podushka, S.B.** 2008b. Sexual differences in the shape of twin fins in Amur sturgeon. *Osetrovoe Khozyaistvo*, 2: 69–71. (In Russian)
- Podushka, S.B. & Chebanov, M.S.** 2007. Caviar oriented sturgeon culture in China. *Nauchno- Tehnicheskii Byulleten` Laboratorii Ikhtiologii INENKO*, 13: 5–15. (In Russian)
- Podushka, S.B. & Levin, A.B.** 1988. Use of olfactory organ malformation as a marker of sturgeon juveniles released by fish hatcheries. *Problems and prospects of fishery in the Perm region. Trudy GosNIORKh*, 281: 132–137. (In Russian)
- Podushka, S.B. & Shebanin, V.M.** 1996. The “excess” pair of fins in the Siberian sturgeon. *Rybovodstvo i Rybolovstvo*, 3–4: 16. (In Russian)
- Ponomarev, S.V., Gamygin, E.A., Nikonorov, S.I., Ponomarev, E.N., Grozesku, Yu.N. & Bakhareva, A.A.** 2002. *Technology of rearing and feeding of aquaculture objects in the south of Russia*. Astrakhan, Nova plus. 263 pp. (In Russian)
- Popova, A.A., Piskunova, L.V. & Shevchenko, V.D.** 2004. Biological and technological rules for building and management of Russian and beluga broodstocks under hatchery conditions in the Volga Delta. *Fisheries studies in the Caspian Sea. Results of R&D year 2003*. Astrakhan, Izdatel'stvo KaspNIIRKh. pp. 496–502. (In Russian)
- Powell, J.** 2008. Saving BC sturgeon. Part 1: landing the big one. *Hatchery International*, 9(5): 1, 13.
- Privezentsev, Yu.A. & Lipko, G.V.** 1987. A biological method of destroying fairy shrimps (Branchiopoda) in nursery ponds. In: Yu.A. Privezentsev, ed. *Izvestiya Timiryazevskoi sel'sko-khozyaistvennoi Akademii*. Moscow, Izdatel'stvo Timiryazevskoi sel'sko- khozyaistvennoi Akademii pp. 178–188. (In Russian)
- Ramsar Declaration on Global Sturgeon Conservation.** 2006. *Journal of Applied Ichthyology*, 22 (Suppl.1): 5–11.
- Reshetnikov, Yu.S.** (ed.) 2002. *Atlas of freshwater fishes in Russia*. Vol. 1. Moscow, Izdatel'stvo “Nauka”. 379 pp. (In Russian)
- Rivkin, V.B. & Kazansky, B.N.** 1979. Effect of temperature on the neuro-endocrine system and pituitary of sturgeons. In L.S. Berdichevsky, ed. *Biological basis of sturgeon culture development in waterbodies of the USSR*. Moscow, Izdatel'stvo “Nauka”. pp. 180–188. (In Russian)

- Rodina, M.** 2006. Application of image analysis for the determination of nucleus position in sturgeon oocytes. *Journal of Applied Ichthyology*, 22: 373–374.
- Romanov A.A., Romanov A.I.A. & Belyaeva E.S.** 2001. Monitoring of histomorphologic alterations in gonadal gametogenesis in sturgeon fish of the Volgo-Caspian region. In: E.S. Belyaeva, ed. *Ecology of juveniles and problems of Caspian fish reproduction*. Moscow, VNIRO. pp. 246–268. (In Russian)
- Romanov N.S.** 2001. Fluctuating asymmetry in hatchery bred and wild trout. *Vladimir Ya. Levanidov's Biennial Memorial Meetings*. Vol. 1. Vladivostok, Dal'nauka. pp. 328–335. (In Russian)
- Rosenthal, H., Bronzi, P., Gessner, J., Moreau, D. & Rochard, E.** (eds.) 2008. *Action plan for the conservation of the restoration of the European sturgeon*. Nature and Environment No. 152, 125 pp.
- Rottmann, R.W., Shireman, J.V. & Chapman, F.A.** 1991. *Techniques for taking and fertilizing the spawn of fish*. Southern Regional Aquaculture Center, SRAC Fact Sheet. Publication No. 426. 8 pp.
- Ruban, G.I.** 2005. *The Siberian sturgeon Acipenser baerii Brandt*. Germania, WSCS, Books on Demand GmbH. 203 pp.
- Ruchin, A.B.** 2007. Effect of photoperiod on growth, physiological and hematologic indices of Siberian sturgeon *Acipenser baerii* fry. *Izvestiya Akademii Nauk, Seriya Biologicheskaya*, 2007. No. 6, pp. 698–704. (In Russian)
- Safronov, A.S., Solokhin, I.V., Nikolaev, A.I., Burlatchenko, I.V., Filippova, O.P. & Dudin, K.V.** 2006. Use of a borescope for early intravital sex identification in sturgeons. In N.V. Sudakova, ed. *Sturgeon aquaculture: achievements and prospects for development*. Proceedings of the 4<sup>th</sup> International Scientific and Practical Conference, Astrakhan March 13–15. Moscow, Izdatel'stvo VNIRO. pp. 121–124. (In Russian)
- Sbikin, Yu.N.** 1973. *Age-related changes in the eyesight of fish under different environmental conditions, associated with peculiarities of their behaviour*. Avtoreferat Dissertatsii na Soiskaniye Uchenoi Stepeni Kandidata Biologicheskikh Nauk. Moscow. Institut Problem Evolyutsii i Ekologii im. A.N. Severtsova Akademii Nauk SSSR, 24 pp. (in Russian)
- Semenkova, T.B., Bayunova, L.V., Kolmakov, N.N. & Barannikova, I.A.** 2006. Using of sex steroids levels assay in early sex identification in sturgeon. In N.V. Sudakova, ed. *Sturgeon aquaculture: achievements and prospects for development*. Proceedings of the 4<sup>th</sup> International Scientific and Practical Conference, Astrakhan March 13–15. Moscow, Izdatel'stvo VNIRO. pp. 124–126. (In Russian)

- Semenkova, T.B., Canario, A.V., Bayunova, L.V., Kolmakov, N.N. & Barannikova, I.A.** 2005. Sex steroids and oocyte maturation in the sterlet (*Acipenser ruthenus* L.). *Journal of Applied Ichthyology*, 22: 340–345.
- Semenkova, T.B. & Trenkler, I.V.** 1993. Effects of photoperiod, epiphysectomy and pharmacological preparations on growth rate and metabolism in young sturgeons. International Symposium on Sturgeons: Abstracts Bulletin. Moscow. pp. 13–14.
- Semenov K.I., 1965.** Effect of prior-to-spawn holding of breeders conditions on their maturation after pituitary administration and on quality of progeny at early developmental stages in Russian sturgeon. In V.I. Vladimirov ed. Effect of breeders quality on progeny in fishes. Kiev. Naukova Dumka. pp. 123–142.
- Serebryakova, E.V.** 1985. Cytological criteria of fish progeny evaluation in aquaculture. In: *Biological basis of aquaculture in the seas of the European part of the USSR*. Moscow. Izdatel'stvo "Nauka". pp. 91–96. (In Russian)
- Shcheglov, M.V., Mineyev, S.V. & Vitvitskaya, L.V.** 2000. Experience in grow out of sturgeon larvae in the current. *Sturgeons at the turn of the 21st century: international conference*. Astrakhan, Izdatel'stvo KaspNIIRKh. pp. 286–288. (In Russian)
- Shevchenko, V.N., Popova, A.A. & Piskunova, L.V.** 2004. Effect of holding conditions of domestic sturgeon females on the length of interspawning cycle. *Aquaculture of sturgeon species. Sturgeon aquaculture: achievements and prospects for the development*, III International Science and Practical Conference. Astrakhan, BIOS. pp. 139–141. (In Russian)
- Shilov, V.I.** 1971. On races, growth, maturity and frequency of sterlet spawning in Volgograd Reservoir. *Trudy GOSNIORKH. Osetrovye v Volgogradskom i Saratovskom Vodohranilishchah*, Vol. 11, pp. 112–153. (In Russian)
- Sorokina, M.N.** 2004. *Efficiency of  $\alpha$ -tocopherol and ascorbic acid application to prepare sturgeon fish to spawn*. Avtoreferat Dissertatsii na Soiskaniye Uchenoi Stepeni Kandidata Biologicheskikh Nauk, Astrakhan, AGTU. 24 pp. (In Russian)
- Sudakova, N.V.** 1998. *Comparative efficiency of synthesis in the starter complex feeds for sturgeon fry*. Avtoreferat Dissertatsii na Soiskaniye Uchenoi Stepeni Kandidata Biologicheskikh Nauk. Moscow, VNIIPRKH. 26 pp. (In Russian)
- Summerfelt, R.C. & Smith, L.S.** 1990. Anesthesia, surgery, and related techniques. In C.B. Shreck & P.B. Moyle, eds. *Methods for fish biology*. Bethesda, MD, American Fisheries Society. pp. 231–272.

- Svardson, G.** 1945. *Chromosome studies on Salmonidae*. Report of the Institute for Freshwater Research, Drottningholm, No. 23, 1–151.
- Sytina, L.A. & Timofeyev, O.B.** 1973. Periodicity of sturgeon development (Acipenseridae) and the problem of organism variability. *Voprosy Ikhtiologii*, Vol. 13 № 2(79): 275–291. (In Russian)
- Tan'kin V.V.** 1979. Characteristics of hatchery quality of sterlet and bester males used for industrial obtaining of hybrids. *Sturgeon culture of the USSR inner waterbodies*. Abstracts of the II All-Union Conference. pp. 255–256. (In Russian)
- Tikhomirov, A.M. & Khabumugisha, Zh.D.** 1997. Pilot testing of new device “Ikhtiotest” on Russian sturgeon juveniles. *Vestnik Astrakhanskii Gosudarstvennyi Technologicheskii Universitet*, 5: 97–98. (In Russian)
- Tikhomirov, A.M. & Nikonorov, S.I.** 2000. Ways of environmental adequacy of artificial reproduction of sturgeon enhancement. *Sturgeons at the turn of the 21st century: international conference*. Astrakhan, KaspNIIRKh. pp. 275–277. (In Russian)
- Timoshkina, N.N.** 2009. *Intraspecific genetics polymorphism of Russian sturgeon (Acipenser gueldenstaedtii)*. Avtoreferat Dissertatsii na Soiskaniye Uchenoi Stepeni Kandidata Biologicheskikh Nauk. Moscow, Institut Biologii Razvitiya RAN. 23 pp. (In Russian)
- Timoshkina, N.N., Barmintseva, A.E., Usatov, A.V. & Mogue, N.S.** 2009. Intraspecific genetic polymorphism of Russian sturgeon *Acipenser gueldenstaedtii*. *Russian Journal of Genetics*, 45(9): 1098–1106.
- Trenkler I.V. & Gruslova A.B.** 2006. The possibilities of receiving of viable sperm from Russian sturgeon and beluga males of “spring” and “winter” forms. *Sturgeon aquaculture: achievements and prospects for development*. 4th International Science and Practical Conference, Moscow, Izdat'el'svo Vserossiiskii Nauchno-Issledovatel'skii Institut Rybnogo Khozyaistva i Okeanografii. pp. 127–129. (In Russian)
- Trusov, V.Z.** 1964. Method of estimation of the degree of gonadal maturity in sturgeon females. *Rybnoe Khozyaistvo*, 1: 26–28. (In Russian)
- Trusov, V.Z.** 1972. Maturation of the gonads of Volga-Caspian sturgeon (*Acipenser gueldenstaedtii*) in the maritime period of life. *Trudy Tsentral'nyi Nauchno-Issledovatel'skii Institut Osetrovogo Rybnogo Khozyaistva*, 4: 95–122. (In Russian)
- Trusov, V.Z. & Pashkin, L.M.** 1964. On optimal dosage for rational utilization of sperm at insemination of sturgeon eggs. *Rybnoe Khozyaistvo*, 3: 16–17. (In Russian)

- Trzebiatowski, R., Stepanovska, K., Siwicki, A.K. & Kazun, K.** 1996. Badania nad przydatnoszcia preparatu propiscin znieczulenia ogolnogo suma Europejskiego. *Komunikaty Rybackie*, 1: 14–18.
- Tsepkin, E.A. & Sokolov, L.I.** 1970. Beluga *Huso huso* (L.) in the later Holocene. *Biologicheskie Nauki*, 5: 11–16. (In Russian)
- Ustaoglu, S. & Okumus, I.** 2004. The sturgeons: fragile species need conservation. *Turkish Journal of Fisheries and Aquatic Sciences*, 4: 49–57.
- Vaini, F., Pazzaglia, M. & Ruzza, C.** 2001. Female identification and checking of ovary development in caviar producing white sturgeon (*Acipenser transmontanus*) – preliminary results. Extended Abstracts of the 4th International Symposium on Sturgeon, Oshkosh, WI. p. 96.
- Valentine, D.W., Soule, M.E. & Samollow, P.** 1973. Asymmetry analysis in fishes: a possible statistical indicator of environmental stress. *Fishery Bulletin*, 71: 357–370.
- Van Eenennaam, J.P., Bruch, R. & Kroll, K.** 2001. Sturgeon sexing, staging maturity and spawning induction workshop. Abstracts of the 4th International Symposium on Sturgeon, Oshkosh, WI, 50 pp.
- Van Eenennaam, J.P. & Doroshov, S.I.** 1998. Effects of age and body size on gonadal development of Atlantic sturgeon. *Journal of Fish Biology*, 53: 624–637.
- Van Eenennaam, J.P., Doroshov, S.I., Moberg, G.P., Watson, J.T. & Linares, J.** 1996. Reproductive conditions of the Atlantic sturgeon (*Acipenser oxyrinchus*) in the Hudson River. *Estuaries*, 19(4): 769–777.
- Vasil'eva, E.D., Kuga, T.I. & Chebanov, M.S.** 2010. Inheritance of some quantitative morphological characters in reciprocal hybrids of starred sturgeon *Acipenser stellatus* and beluga *A. huso* (Acipenseridae). *Voprosy Itkiologii*, 50 (1): 20–27.
- Vecsei, P., Litvak, M.K., Noakes, D.L.G., Rien, T. & Hochleithner, M.** 2003. A noninvasive technique for determining sex of live adult North American sturgeons. *Environmental Biology of Fishes*, 68: 333–338.
- Vladikov, V.D.** 1931. Poissons de la Russie Sous-Carpathique (Tchecoslovaquie). *Mémoires de la Société Zoologique de France*, 29: 217–374. (not seen)
- Vlasenko, A.D., Pavlov, A.V., Sokolov, L.I. & Vasilev, V.P.** 1989. *Acipenser gueldenstaedtii* Brandt, 1883. In J. Holčík, ed. *The freshwater fishes of Europe*. Vol. 1. Pt. II. General introduction of fishes, Acipenseriformes. Wesbaden, AULA-Verlag. pp. 294–344.
- Vøllestad L.A. & Hindar K.** 1997. Developmental stability and environmental stress in Atlantic salmon *Salmo salar*. *Heredity*, 78: 215–222.

- Vorobyeva A.A. & Nikonova R.S.** 1987. Gammarids – *Dikerogammarus haemobaphes* (Eichwald) and *Niphargoides maeoticus* (Sowinsky) as object of culture. *Gidrobiologicheskii Zhurnal*, 12 (6): 52–56.
- Vorobyeva, E.I. & Markov, K.P.** 1999. Specific ultrastructural features of eggs of Acipenseridae in relation to reproductive biology and phylogeny. *Voprosy Ikhtiologii*, 39(8): 157–169.
- Vorobyeva, O.A. & Podushka, S.B.** 1999. Variability in number of micropyle in eggs of Don Russian sturgeon, *A. gueldenstaedtii*. *Nauchno-Tekhnicheskii Byulleten Laboratorii Ikhtiologii INENKO*, 1: 24–28. (In Russian)
- Wakeford, A.** 2001. *State of Florida conservation plan for gulf sturgeon* (*Acipenser oxyrinchus desotoi*). Florida Marine Research Institute Technical Report TR-8. 100 pp.
- Webb, M.A.H., Doroshov, S., Rasco, R., Cavinato, A., Sealey, W., Fornshell, G., Lemon, L. & Ray, L.** 2009. *Determining ripeness in white sturgeon females to maximize yield and quality of caviar*. Annual Progress Report. Part II. Western Region Aquaculture Center, United States Department of Agriculture. pp. 1–36.
- Webb, M.A.H., Feist, G.W., Foster, E.P., Schreck, C.B. & Fitzpatrick, M.S.** 2001. Classification of sex and stage of maturity of white sturgeon (*Acipenser transmontanus*). Abstracts of the 4th International Symposium on Sturgeon, Oshkosh, WI, LH73.
- Webb, M.A.H., Feist, G.W., Foster, E.P., Schreck, C.B. & Fitzpatrick, M.S.** 2002. Potential classification of sex and stage of gonadal maturity of wild white sturgeon using blood plasma indicators. *Transactions of the American Fisheries Society*, 131: 132–142.
- Whitlock, M.** 1998. The repeatability of fluctuating asymmetry: a revision and extension. *Proceedings of the Royal Society of London, B*, 265: 1429–1431.
- Williot, P.** 1997. Effect of incubation media on maturation of isolated ovarian follicles of Siberian sturgeon (*Acipenser baerii* Brandt) induced by sturgeon gonadotropic preparation or 17 alpha, 20 beta-dihydroxyprogesterone. *Comparative Biochemistry and Physiology*, 118C(3): 285–293.
- Williot P.** 2002. Reproduction. In R. Billard ed. *Esturgeons et caviar*. Éditions Tec & Doc, Lavoisier. pp. 63–90.
- Williot, P., Arlati, G., Chebanov, M.S., Gulyas, T., Kasimov, R., Kirschbaum, F., Patriche, N., Pavlovskaya, L.P., Poliakova, L., Pourkazemi, M., Kim, Yu., Zhuang, P. & Zholdasova, I.M.** 2002. Status and management of Eurasian sturgeon: an overview. *International Review of Hydrobiology*, 87(5–6): 483–506.



- Williot, P., Bronzi, P., Benoit, P., Bonpant, E., Chebanov, M., Domezain, A., Gessner, J., Gulyas, T., Kolman, R., Michaels, J., Sabeau, L. & Vizziano, D.** 2006. *Cultured aquatic species information programme*. *Acipenser baerii*. FAO, Rome. (available at: [http://www.fao.org/figis/servlet/static?dom=culturespecies&xml=Acipenser\\_baerii.xml](http://www.fao.org/figis/servlet/static?dom=culturespecies&xml=Acipenser_baerii.xml))
- Williot, P. & Brun, R.** 1998. Ovarian development and cycles in cultured Siberian sturgeon, *Acipenser baerii*. *Aquatic Living Resources*, 11(2): 111–118.
- Williot, P., Brun, R. & Rooryck O.** 1991. Management of female breeders of the Siberian sturgeon, *Acipenser baerii* Brandt. First results. In P. Williot, ed. *Acipenser*, Bordeaux, Cemagref Publ. pp. 365–379.
- Williot, P., Brun, R., Rouault, T., Pelard, M. & Mercel, D.** 2005. Attempts at larval rearing of the endangered western European sturgeon, *Acipenser sturio* (Acipenseridae), in France. *Cybium*, 29(4): 381–387.
- Williot, P., Rochard, E., Castelnaud, G., Rouault, T., Brun, R., Lepage, M. & Elie, P.** 1997. Biological characteristics of European Atlantic sturgeon, *Acipenser sturio*, as the basis for a restoration program in France. *Environmental Biology of Fishes*, 48: 359–370.
- Williot, P., Rouault, T., Pelard, M., Mercel, D. & Jacobs, L.** 2009. Artificial reproduction and larval rearing of captive endangered Atlantic sturgeon *Acipenser sturio*. *Endangered Species Research*, 6: 251–257.
- Williot, P., Rouault, T., Pelard, M., Mercel, D., Mercier, D., Lepage, M., Davail-Cuisset, B., Kirschbaum, F. & Ludwig, A.** 2007. Building a broodstock of the critically endangered sturgeon *Acipenser sturio* L.: problems and observations associated with the adaptation of wild-caught fish to hatchery conditions. *Cybium*, 31: 3–11.
- Wooster, G.A., Hsu, H.M. & Bowser, P.R.** 1993. Nonlethal surgical procedures for obtaining tissue samples for fish health inspections. *Journal of Aquatic Animal Health*, 5: 157–164.
- Wuertz, S., Nitsche, A., Gessner, J., Kirschbaum, F. & Kloas, W.** 2005. IGF-I and its role in maturing gonads of female sterlet, *Acipenser ruthenus* Linnaeus, 1758. *Journal of Applied Ichthyology*, 22: 346–352.
- Zaikina, A.I.** 1975. *Enhancement of pond production in sturgeon hatcheries*. Moscow, PishcheProm. 111 pp. (In Russian)
- Zakharov, V.M. & Clarke, G.M.** (eds.) 1993. *Biotest: a new integrated biological approach for assessing the condition of natural environments*. Moscow, Moscow Affiliate of the International Biotest Foundation. 59 pp. (In Russian)



- 
- Zheltenkova, M.V.** 1964. Sturgeon feeding in southern seas. *Trudy VNIRO*, 54: 9–48. (In Russian)
- Zhukinsky, V.N.** 1986. *Affect of abiotic factors on quality variation and viability during early ontogenesis*. Moscow, Agropromizdat. 245 pp. (In Russian)
- Zubova, S.E.** 1971. Time of gonad differentiation and correlation of males and females of Volga sterlet sturgeon juveniles. *Voprosy Ikhtiologii*, 11(3): 524–526. (In Russian)



This *Sturgeon Hatchery Manual* includes the latest available scientific research findings and experiences and compiles advice given in earlier manuals and handbooks on sturgeon culture and reproduction practices. This document was prepared in response to numerous requests for practical guidance on this subject from the Central Asian and Caucasus region to the Food and Agriculture Organization of the United Nations (FAO).

This manual is targeted particularly at sturgeon farmers, sturgeon hatchery operators, hatchery technicians, and fisheries and aquaculture managers involved in sturgeon aquaculture development and the restocking and rehabilitation of sturgeon populations in the countries around the basins of the Black and Caspian seas. It aims to provide a practical handbook of modern sturgeon hatchery practices and management. The manual is available in the English, Russian and Turkish languages.

