

# A step-by-step guide to building a traditional double-ended timber fishing craft of Khmer (Cambodian) design



A step-by-step guide to  
**building a traditional double-ended timber  
fishing craft of Khmer (Cambodian) design**

by

Mike Savins

THE FOOD AND AGRICULTURE ORGANIZATION OF THE UNITED NATIONS  
REGIONAL OFFICE FOR ASIA AND THE PACIFIC  
BANGKOK, 2013

The designations employed and the presentation of material in this information product do not imply the expression of any opinion whatsoever on the part of the Food and Agriculture Organization of the United Nations (FAO) or AECID concerning the legal or development status of any country, territory, city or area or of its authorities, or concerning the delimitation of its frontiers or boundaries. The mention of specific companies or products of manufacturers, whether or not these have been patented, does not imply that these have been endorsed or recommended by FAO or AECID in preference to others of a similar nature that are not mentioned.

ISBN 978-92-5-107376-6

FAO encourages the use, reproduction and dissemination of material in this information product. Except where otherwise indicated, material may be copied, downloaded and printed for private study, research and teaching purposes, or for use in non-commercial products or services, provided that appropriate acknowledgement of FAO as the source and copyright holder is given and that FAO's endorsement of users' views, products or services is not implied in any way.

All requests for translation and adaptation rights, and for resale and other commercial use rights should be made via [www.fao.org/contact-us/licence-request](http://www.fao.org/contact-us/licence-request) or addressed to [copyright@fao.org](mailto:copyright@fao.org).

FAO information products are available on the FAO website ([www.fao.org/publications](http://www.fao.org/publications)) and can be purchased through [publications-sales@fao.org](mailto:publications-sales@fao.org).

© FAO 2013

**Citation:**

Savins, M (2013). A step-by-step guide to building a traditional double-ended timber fishing craft of Khmer (Cambodian) design. FAO Regional Office for Asia and the Pacific, Bangkok, Thailand, RAP Publication 2013/07, 56p.

# Foreword

In the developing world, accidents and deaths are frequent in small-scale fishing operations. Most direct casualties are male fishers, but the tragic consequences of accidents at sea are borne by women and children who are at risk of poverty caused by loss of a fisher and are typically without insurance cover and social welfare.

Small-scale fishing fleets are usually made up of small traditional craft, often non-motorized and ill-equipped for navigation, communication and safety. There are few harbour facilities, while crews have little or no training in maritime safety. In addition, the design and construction of vessels themselves can contribute to accidents and loss of life at sea. This is especially the case where effective institutional arrangements and regulatory frameworks are lacking and/or poorly enforced.

As part of its efforts to enhance safety at sea and reduce the vulnerability of fishers the FAO Regional Fisheries Livelihoods Programme for South and Southeast Asia (RFLP) funded by Spain helped build the capacity of Cambodian boat builders to construct a safer design of fishing boat.

This publication provides an illustrated guide to the step-by-step processes involved. Although this work took place in Cambodia the skills and steps involved are widely relevant to those involved in traditional boat building. This publication should therefore act as a valuable addition to the body of knowledge in this area and as a resource for those working or seeking to build capacity in this field.



Hiroyuki Konuma  
FAO Assistant Director-General and Regional Representative for  
Asia and the Pacific

## Acknowledgements

The activities detailed in this publication have been planned, executed and documented through the valuable input of a wide range of collaborators. Special note must go to Øyvind Guldbrandsen, Thay Somony, Khim Wirya, Yos Chanthana, Chan Sokha, Robert Lee, Jose Parajua, Don Griffiths and Steve Needham.

## The Regional Fisheries Livelihoods Programme for South and Southeast Asia (RFLP)

The Regional Fisheries Livelihoods Programme for South and Southeast Asia (RFLP) set out to strengthen capacity and reduce vulnerability among participating small-scale fishing communities and their supporting institutions in Cambodia, Indonesia, the Philippines, Sri Lanka, Timor-Leste and Viet Nam. By doing so RFLP helped improve the livelihoods of fishers and their families while fostering more sustainable fisheries resources management practices.

The four-year (2009–2013) RFLP was funded by the Kingdom of Spain and implemented by the Food and Agriculture Organization of the United Nations (FAO) working in close collaboration with national authorities in participating countries.

A major area of RFLP activity focussed on enhancing safety at sea and reducing vulnerability of small-scale fishers and their families. The development of a safer fishing vessel for Cambodian fishers was one activity that took place in this regard. Other actions included the establishment of accident reporting systems, training on basic safety at sea techniques, provision of equipment such as lifejackets, installation of infrastructure including landing lights and support to disaster preparedness planning as well as early warning systems.

For more information see [www.rflp.org/safety\\_at\\_sea](http://www.rflp.org/safety_at_sea)

# Table of contents

Foreword	iii
Acknowledgements	iv
The Regional Fisheries Livelihoods Programme for South and Southeast Asia (RFLP)	iv
Introduction	1
A step-by-step guide to building a traditional double-ended timber fishing craft of Khmer (Cambodian) design	5
Annexes	
1. General arrangement	39
2. Lines – round bottom	41
3. Simplified – round bottom	43
4. Construction	45
5. Midship section	47
6. Stern	49
7. Details	51
8. Alternative planking	53
9. Stern – inboard engine	55

# Introduction

All over the world, the designs and construction methods for traditional wooden boats have developed over centuries. These inevitably take into account local fishing methods, distance to fishing grounds and availability of building materials (timber and hardware) while some have also been influenced by foreign designs.

Traditional designs seldom change although the availability of new building materials and hardware do influence changes in construction methods. These can make vessels longer lasting and more resistant to the effects of monsoonal rains, sea salt water, marine fouling and marine borers.

Throughout Southeast Asia there are strong traditions in boat building. These are often linked not only to the natural elements but also to cultural beliefs which are deeply engrained in local fisher communities.

Fishing boats are commonly built to locally acceptable standards which have evolved within the context of activities carried out by coastal communities. These standards and designs also tend to be very much in line with local affordability.

However, the quality of a vessel, which is reflected in its sea kindliness and longevity, not only depends on the materials used but to a great part on the experience and skills of the boat builder.

Very often, quality is compromised by the limited financial resources of the fisher. For example, the fisher's budget may not allow for the use of high quality woods and hardware. The boat builder will deliver a lower quality boat to the fisher who is absolutely aware that the life span will be reduced.

Good quality and suitable boat building materials and wood in particular are becoming increasingly difficult to find. As a result, construction costs rise and quality may subsequently be sacrificed for affordability. Furthermore, the adoption of new and evolving fishing operations and gears can lead to greater stresses and demands which may be beyond the safe capacity of traditionally designed fishing craft. Boats therefore need to be built more robustly to accommodate these new operations.

In addition, as fish stocks are placed under considerable fishing pressure, fishers engaged in marine capture fishing tend to move further offshore and travel longer distances in search of more lucrative fishing grounds. These un-traditional operations inevitably compromise safety.

So, while traditional designs and construction methods are deeply engrained in local culture and available materials, scarcity of fish, fishing further out and changing fishing operations present new challenges. These can realistically only be addressed by improving traditional designs and construction methods. The key challenge is how to improve such designs in a cost effective manner.

There are very high levels of skills in boatbuilding in Cambodia. However, as in any unregulated industry, opportunists operate, often under-pricing experienced boat builders to gain employment. These lesser experienced builders generally have limited experience and knowledge related to the quality of timber as well as the use of better fastenings and hardware and employ poor construction methods and practices. This is more prevalent in urban areas where strong demand for boats exists. In rural locations skill levels remain high due to the reputation of recognized skilled artisans. However, even experienced boat builders in Cambodia at times use poorly cured and low quality wood in order to reduce costs.

### Introducing a safer design, and building capacity of boat builders in Cambodia

In 2010, the Regional Fisheries Livelihoods Programme (RFLP) held consultations with Community Fisheries after concerns were raised regarding the stability of the most common traditional 12 meter timber fishing vessel. The project confirmed that these concerns were correct by carrying out stability tests using the rolling period method.

The traditional design was found to be unstable, particularly with increased loading typical with the continual evolution of modern and heavier fishing equipment and their operations.

In order to address this problem and as part of its efforts to reduce vulnerability and improve the safety of coastal fishers, RFLP engaged an FAO naval architect and a master boat builder to develop an improved design for a traditional 12 meter wooden 'long stern' fishing boat. In addition, to being more stable, another objective of this new design was to increase the longevity and reduce cost by using less timber. These were accomplished by using improved construction techniques that do not rely on timber being cut to the full length of the vessel. Improved selection of appropriate and quality timber also helped to ensure longevity.

RFLP designed the intervention in two parts. In the first phase, a master boat builder was hired to make an on the ground assessment and to review:

- Existing policies, laws and regulations related to safety at sea and vulnerability of coastal fishing communities including navigation, and to provide recommendations for improvement; and,
- Review current standards for fishing vessel design, construction, equipment, servicing, maintenance, inspection and licensing and make recommendations for improvement.

The consultant identified poor construction methods, and the instability of traditional wooden boats as being the major safety risks for small-scale fishers. Thereafter, it was decided to introduce an improved and more stable boat.

Once these deficits were identified the project's naval architect and boat builder made measurements and together prepared a modified and improved design and scantlings<sup>1</sup> of the "long stern" boat.

In order to make the boat more secure and safer, a keel and hog construction system was used. This is a doubling of the present traditional backbone system. A sacrificial keel protection was also included to protect the keel from marine worm attack, therefore saving on expensive replacement, maintenance and repair costs of this part of the boat which is almost permanently under water.

In the Cambodian traditional design, local boat builders use naturally curved timbers directly from the trees to make the frames. However, it is time consuming and becoming ever more difficult to find such naturally curved pieces of wood, mainly due to the depletion of forest resources. To deal with this problem, the modified design introduces a new frame construction method which uses two shorter, straight timbers joined together with a wooden gusset, instead of a longer single piece of naturally curved timber.

<sup>1</sup> The dimensions of building materials, especially the width and thickness of the timber. These are calculated to withstand the expected forces and stresses that the boat will be put under during its normal operations and are mathematically calculated based on laboratory tests and material properties.



Design drawings for the new improved boat design are annexed to this manual. These drawings are for both inboard and outboard engine configurations. The design constructed during this initiative was powered by a 13 horse power long-tail petrol engine.

The diagram below shows the cross-section configuration of a 12 meter wooden traditional Cambodian long stern fishing boat (solid line) and the improved more stable boat design (dot and dash line). It can be seen that the freeboard<sup>2</sup> of the modified design is increased.

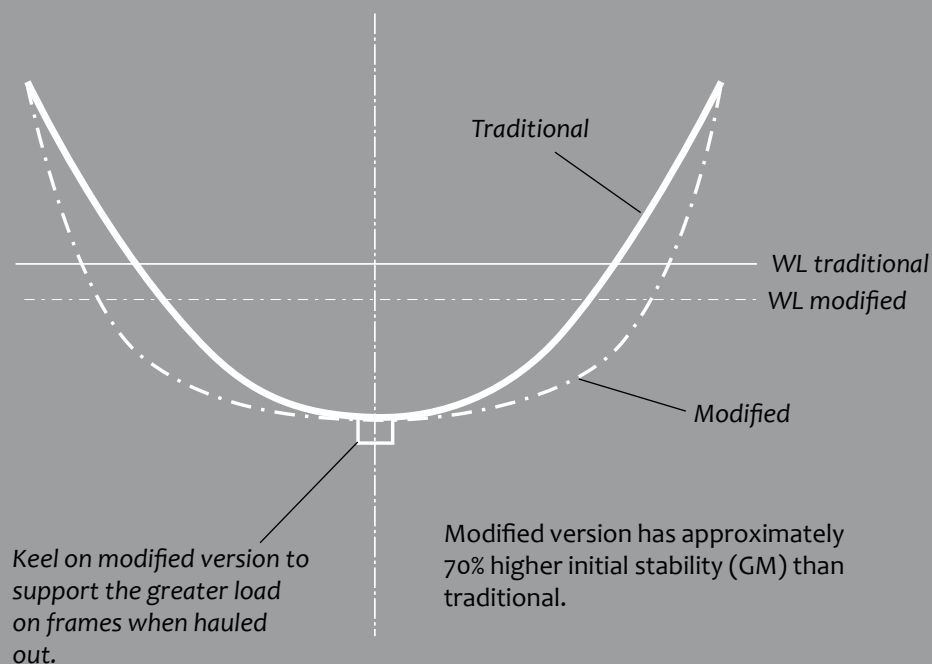

**12 m Cambodia  
MIDSHIP SECTION  
Scale = 1:10**

The cost of building a boat to the new design is approximately USD 2 600. This is some 50–60 percent higher than the traditional design which costs in the region of USD 1 500–1 700 per boat. It is envisaged however that this additional cost would be offset by the longer operational life of the new design boats which are estimated to last 12–15 years in comparison to the 8–10 years of the traditional design.

<sup>2</sup> The vertical distance from the waterline to the gunwale.

## Introduction

Once the new boat design had been finalized, RFLP trained 18 Cambodian boat builders including members of the Community Fisheries which were working partners with RFLP in its construction. The hands-on boat building course lasted twelve days (8 to 20 August 2011) and took place in Preah Sihanouk Province. During the course two boats were constructed under the supervision of the master boat builder.

In addition to constructing the boats the participants also learned a variety of construction techniques that can be used to improve the safety and longevity of any vessel they build such as how to select and dry quality timber. They furthermore were trained in the new skill of lofting, which is the process of drawing the shape of the new improved boat design in cross section to be able to guarantee replication of the new hull outline.

Following the course and over the following 4–5 months, the trained boat builders constructed seven more boats of the same design. In June 2012, all of these nine vessels were donated by RFLP to Community Fisheries to carry out patrolling activities.

# Steps

Step by step  
guide  
to building  
a traditional  
timber fishing  
craft



The completed boats ready for handover to  
Community Fisheries in June 2012.

## Step 1 A. Fastenings are very important in boat building and improved safety of boats.

These are square section hot dipped galvanized nails. They have good diameter thickness and are suitable where strength or holding capabilities are required.



This is a cup head hot dipped galvanized bolt with hot dipped galvanized nut and washer. The hot dipped galvanized coating, makes them ideal for boat building.



These nails are electroplated, which is an extremely thin film type coating. They are normally more shiny than galvanized nails. They are unsuitable for boat building.



These are round shank hot dipped galvanized nails. They are very thin in diameter and are unsuitable where strength or holding capabilities are required.



The frame thickness must be sufficient to allow for the large hole diameter when using treenails.

Boat builders in Cambodia still utilize timber nails called "treenails" which are very effective. Many countries have moved to using steel nails, believing them to be stronger. However steel will rust in a marine environment. This is why hot dipped galvanizing is so important for metal fastenings. Timber tree nails also remain an effective fastening.

**Step 1.** Timber for planking of boats, must be dried for approximately three months. This stops the planking from shrinking when fastened on the boat and significantly reduces water leakage.

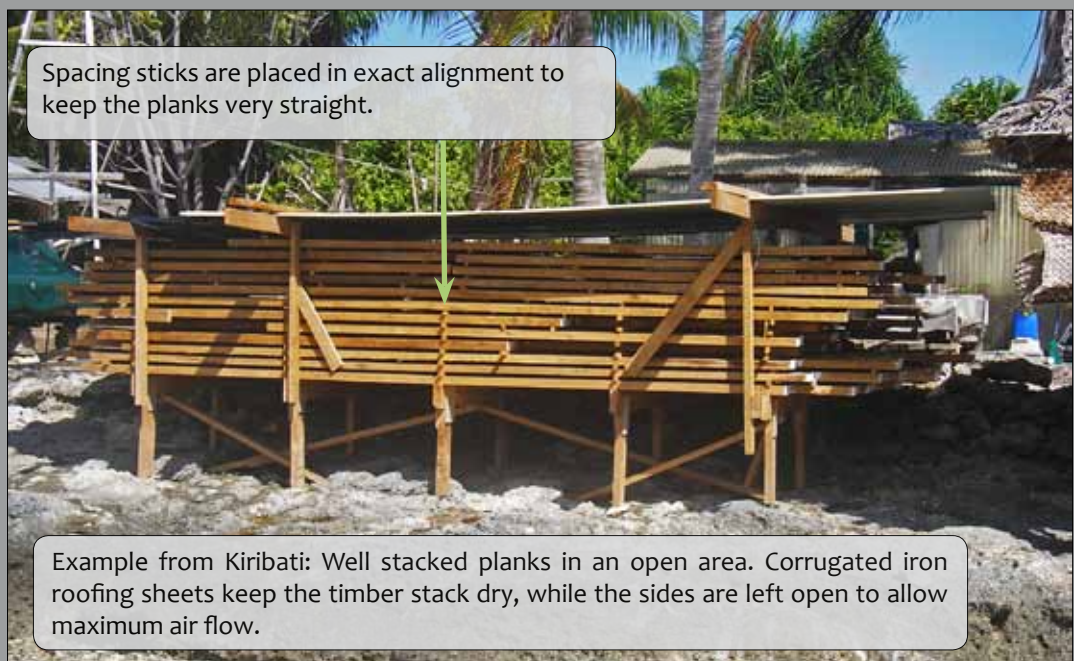
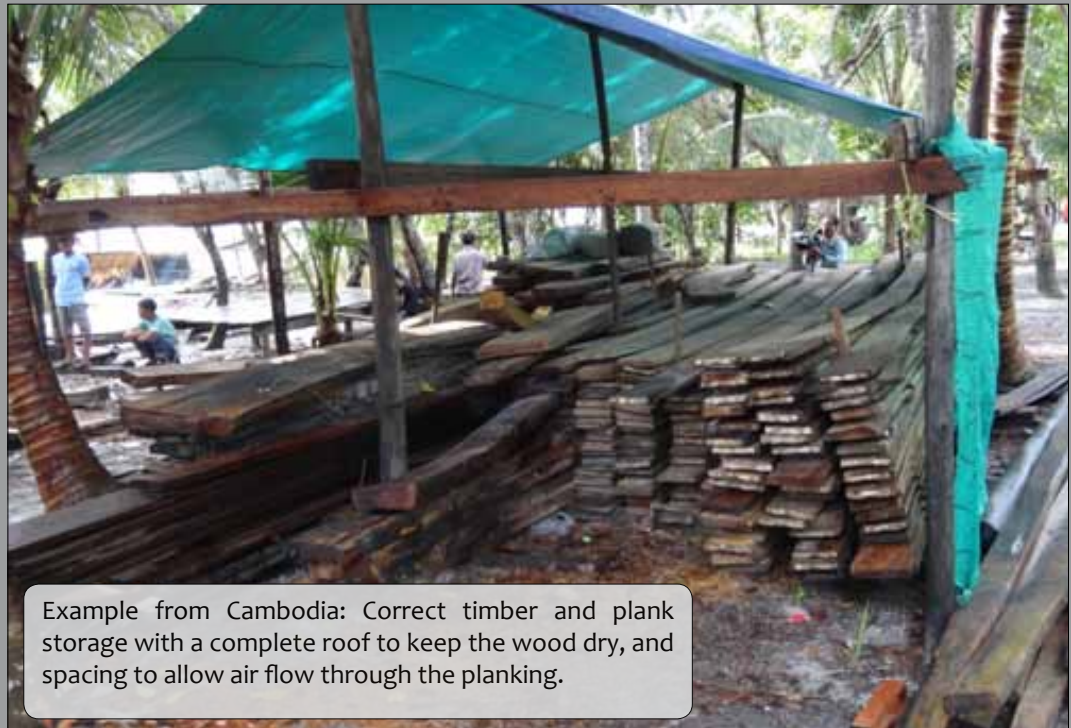

**Step 2.** The keel timber is cut and planed to size. The building base is built. A string line helps fix the keel straight ready for building the boat. In this photo two boats are being built simultaneously.



**Step 3.** A natural bend in suitable timber is selected and shaped for the stem. Note that the shape of the stem and also the stern of the boat is determined by the experience of local boat builders.



**Step 4.** The stem is rebated to allow for the planking. Note that the first cutting is only temporary; the final shape is made using the planks as the guide to determine the exact shape.



**Step 5.** Fitting the stem to the keel.



The angle of the stem is determined by the experience of local boat builders.

Note that the alignment must allow for the planking to fit correctly.

## Step 6.

The forward top edge of the keel is shaped to suit the edge of the garboard plank (first plank).



The experience of local boat builders is essential to achieve correct edges, so that the first plank can be correctly caulked water tight.

The bevel changes to suit the plank, as it fits to the stem, then bends to form the bottom of the boat.

## Step 7.

The hog timber is placed on the keel and the frame spacing is marked out. The correct hog timber shape is cut and planed to suit the planking. Note this is done before the hog is bolted to the keel.

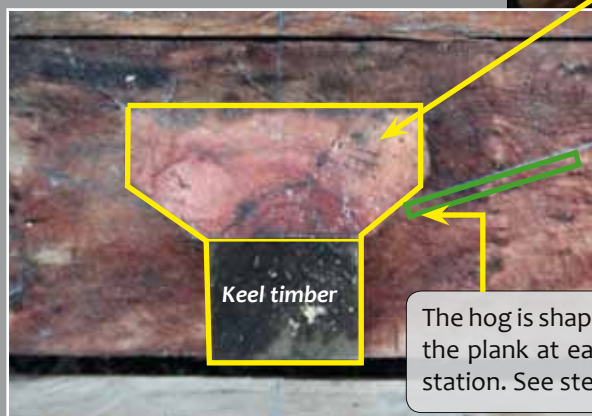
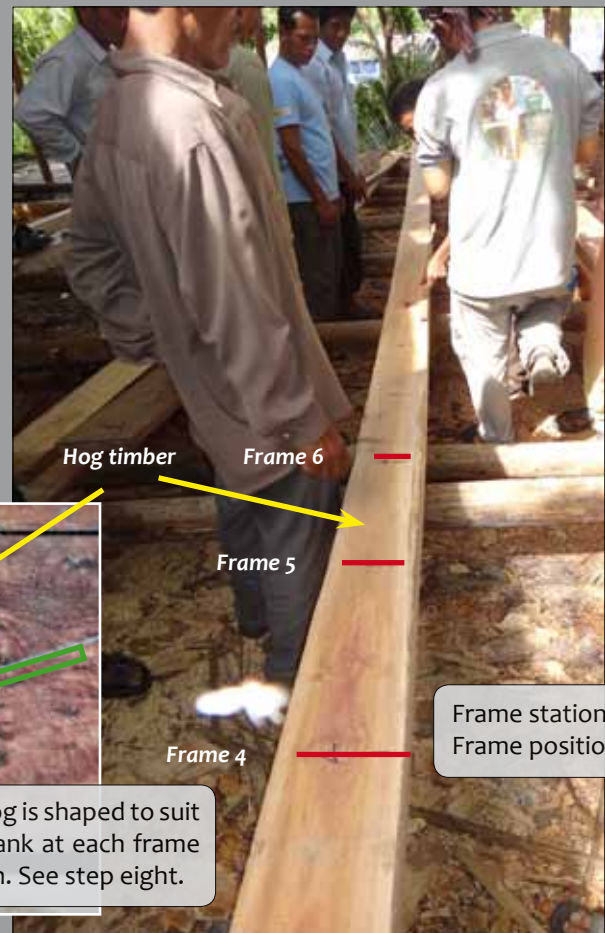

The hog is shaped to suit the plank at each frame station. See step eight.

Frame stations. Frame positions.



## Step 8. Drawing out the frames.



Frame	10	14	18
Height from Baseline (mm)			
A Rabbet	208	258	311
B Chine	621	583	608
C Sheer	1190	1180	1189
D Round	43	52	49
Half width from centre line (mm)			
E Rabbet	48	48	48
F Chine	946	1009	919
G Sheer	1092	1113	1089

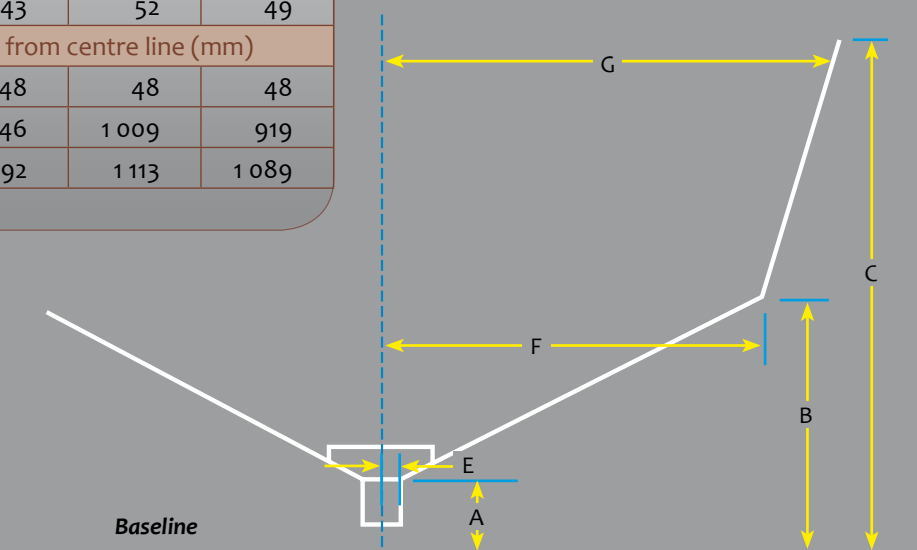

## Step 9. Developing the correct round bilge hull shape.

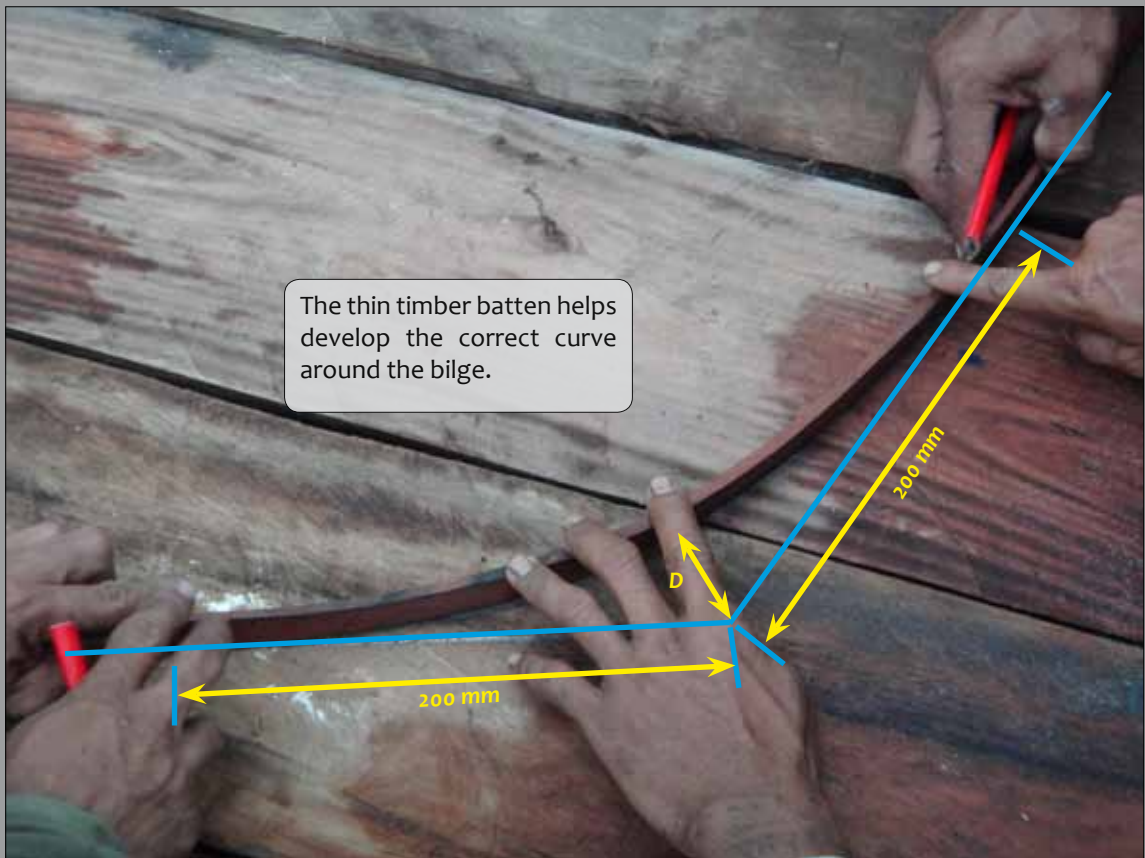

# Step 10. The hog is shaped to suit the measurements obtained when drawing the frames.

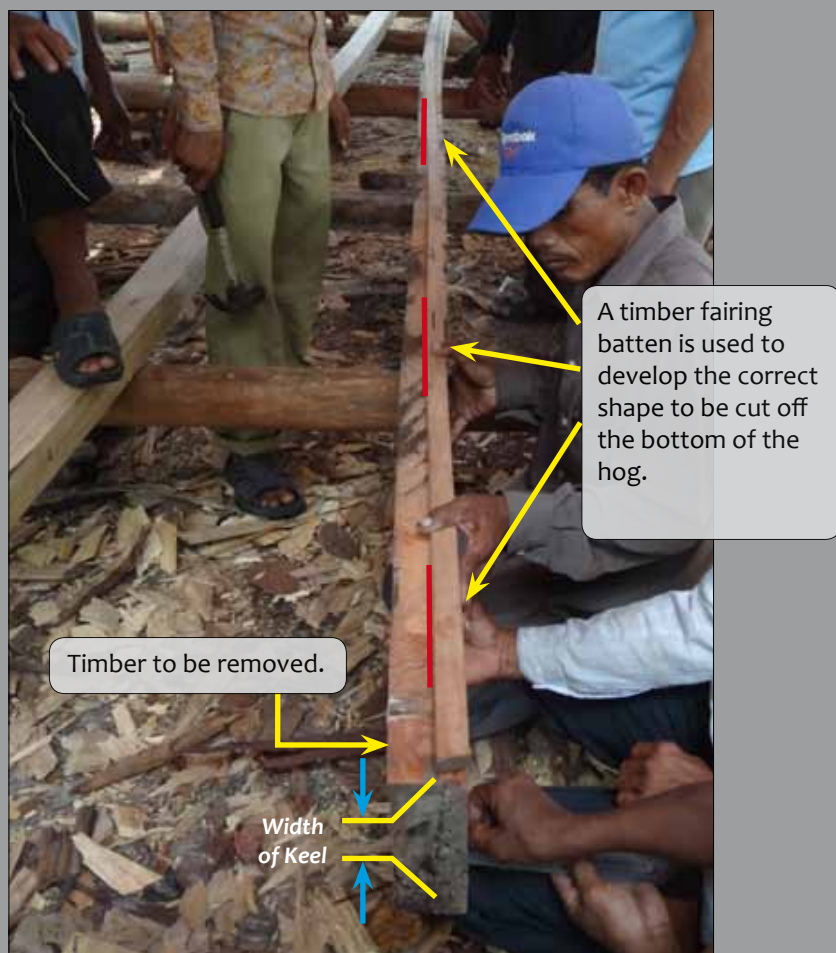
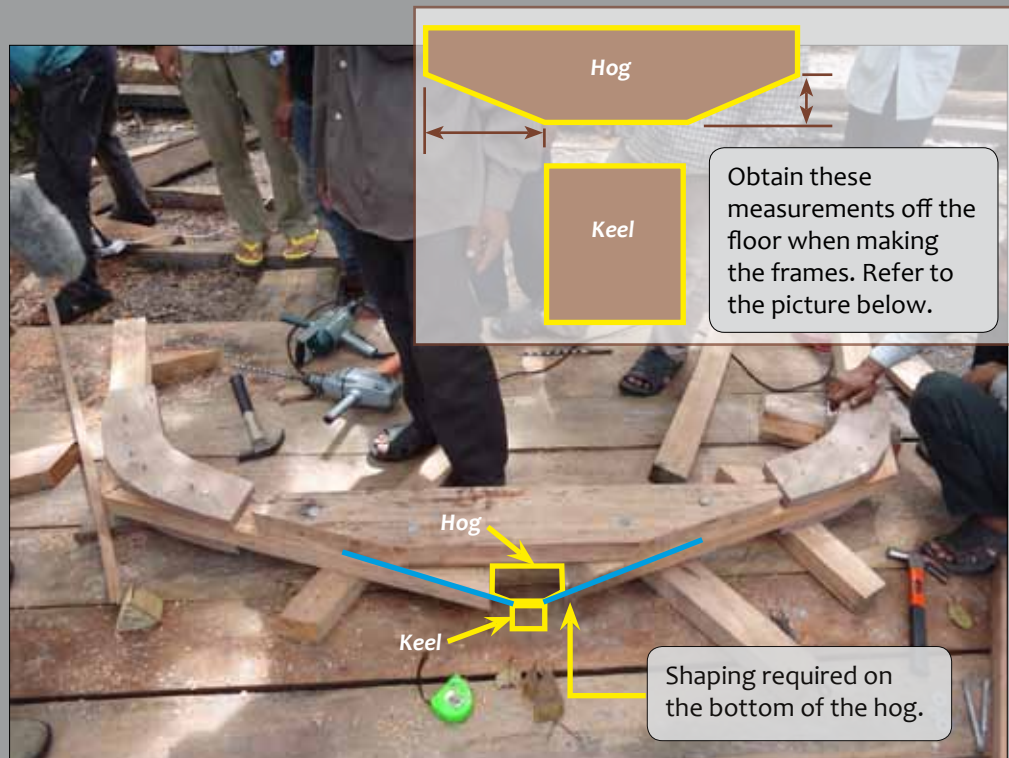

## Step 11. The hog is bolted on top of the keel.



**Step 12.** The hog must now be shaped at both ends to ensure the planking will fit correctly to the hog and the stem, plus the hog and stern at the back of the boat.



### Step 13. A connection knee is fitted at the front and the back of the boat.



### Step 14. The frames are placed on the boat in the correct position and bolted through the hog and keel. Frame 10, frame 14 and frame 18 are enough to ensure the boat is built to the correct round bilge hull shape with its greater width that ensures improved stability.



**Step 15.** A timber stop water approximately 10 mm in diameter is positioned exactly on the caulking line where the keel and stem join. This prevents water from entering the boat through the join.

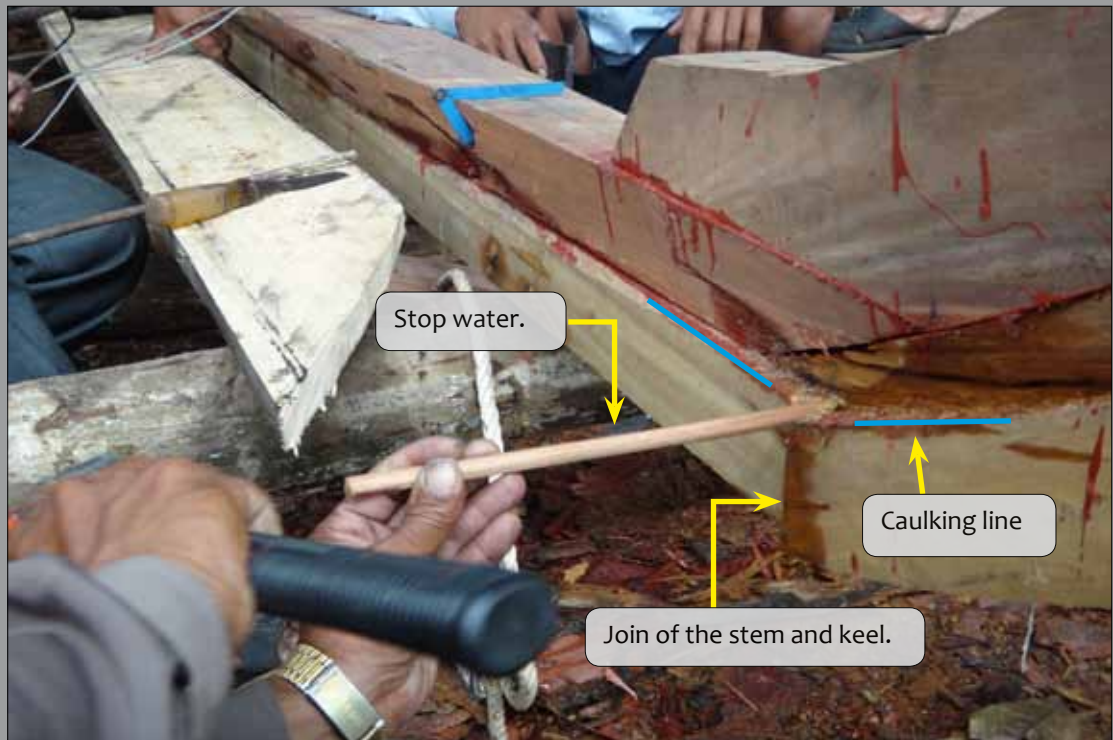

## Step 16. Taking bevels of the hog and keel for the bottom edge of the garboard plank (first bottom plank).



These bevels are transferred onto the bottom edge of the bottom plank, and the plank is shaped ready for placing on the boat.





## Step 17. The first planks are placed on the boat.

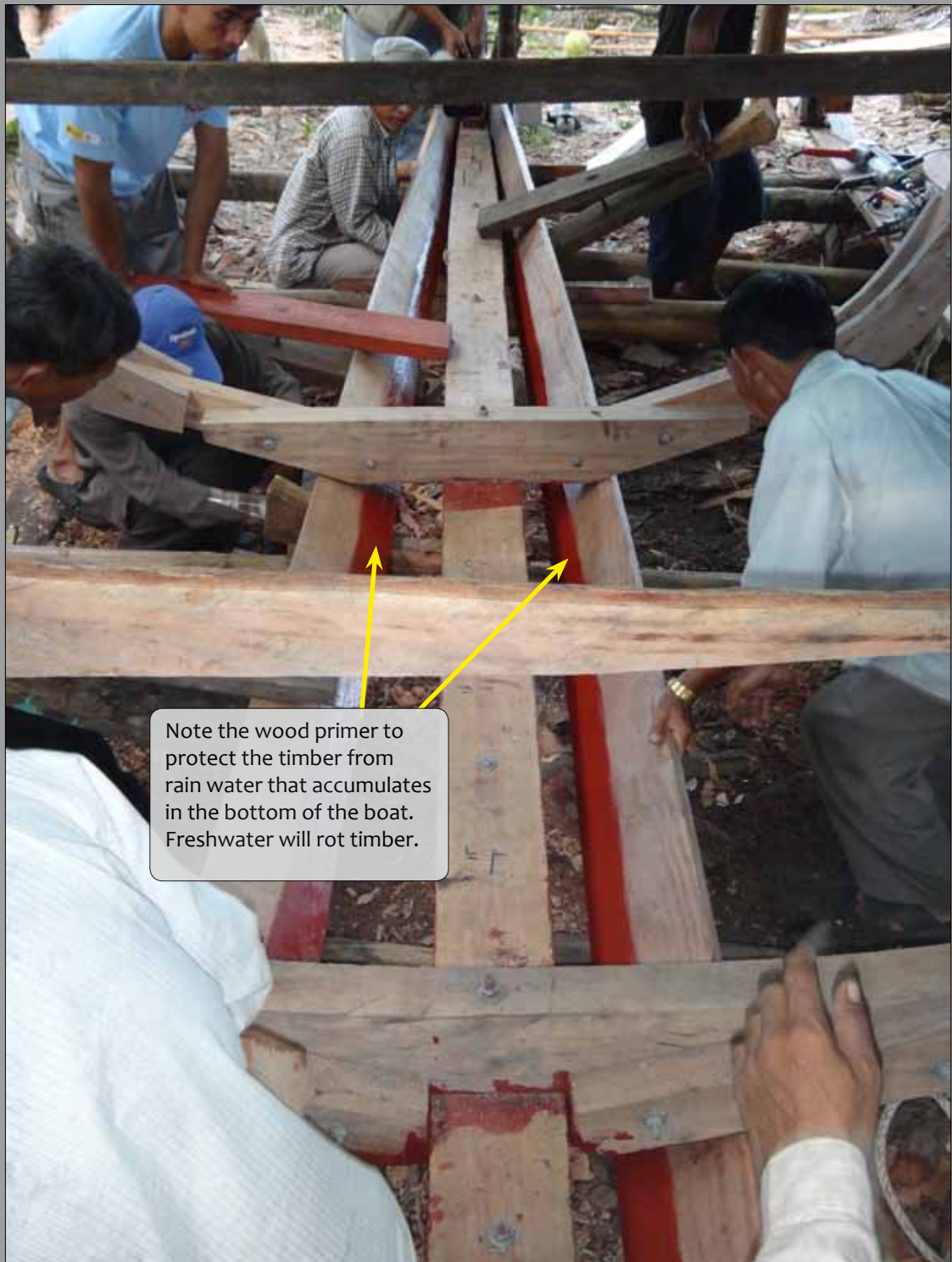

**Step 18.** All nail holes must be pre-drilled to avoid the timber planks cracking.



**Step 19.** All timber planks below the water line must have the edges painted with anti-fouling paint. This helps prevent marine worm attack.

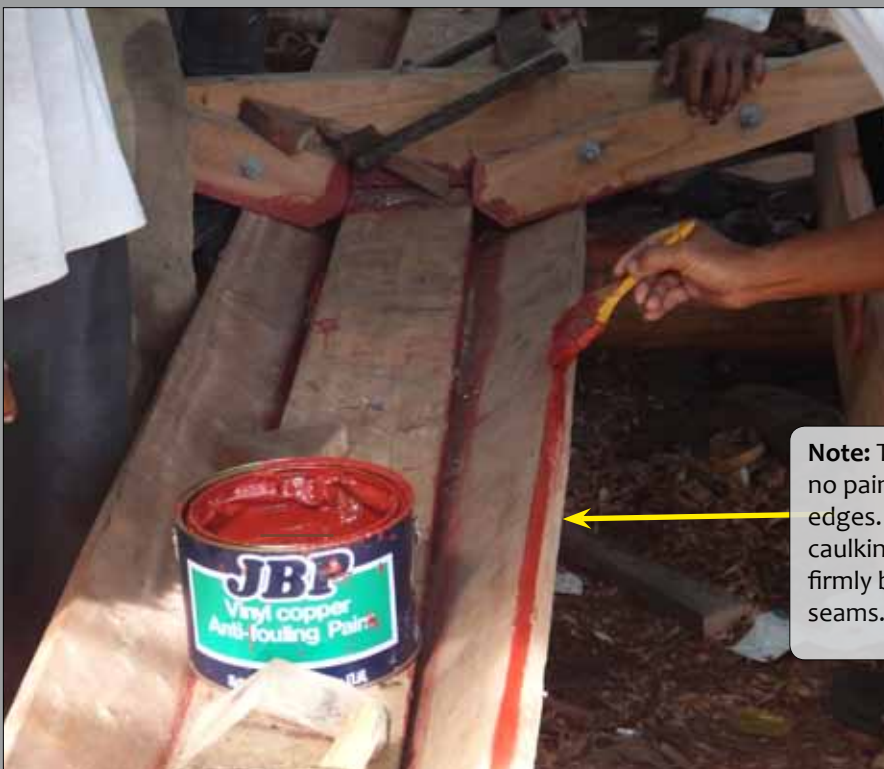

**Note:** The planks have no paint on the outer edges. This allows the caulking to grip more firmly between the plank seams.

**Step 20.** The first bottom planks are continued back to the stern of the boat.

