

# Materials for subsurface land drainage systems



---

**Copies of FAO publications can be requested from:**

SALES AND MARKETING GROUP  
Information Division  
Food and Agriculture Organization of the United Nations  
Viale delle Terme di Caracalla  
00100 Rome, Italy

**E-mail:** [publications-sales@fao.org](mailto:publications-sales@fao.org)

**Fax:** (+39) 06 57053360

**Web site:** <http://www.fao.org>

# Materials for subsurface land drainage systems

FAO  
IRRIGATION  
AND  
DRAINAGE  
PAPER

**60**

Rev. 1

by

**L.C.P.M. Stuyt**

ALTERRA, Green World Research  
Wageningen, The Netherlands

**W. Dierickx**

Department for Agricultural Engineering  
Merelbeke, Belgium

**J. Martínez Beltrán**

Water Resources, Development and Management Service  
FAO Land and Water Development Division

The designations employed and the presentation of material in this information product do not imply the expression of any opinion whatsoever on the part of the Food and Agriculture Organization of the United Nations concerning the legal or development status of any country, territory, city or area or of its authorities, or concerning the delimitation of its frontiers or boundaries.

ISBN 92-5-105427-4

All rights reserved. Reproduction and dissemination of material in this information product for educational or other non-commercial purposes are authorized without any prior written permission from the copyright holders provided the source is fully acknowledged. Reproduction of material in this information product for resale or other commercial purposes is prohibited without written permission of the copyright holders. Applications for such permission should be addressed to:

Chief

Publishing Management Service

Information Division

FAO

Viale delle Terme di Caracalla, 00100 Rome, Italy

or by e-mail to:

[copyright@fao.org](mailto:copyright@fao.org)

© FAO 2005

# Contents

	page
1 INTRODUCTION	1
History	1
Contemporary drainage materials	2
Problems with drainage materials	3
Scope of this publication	3
2 DRAINAGE PIPES, ACCESSORIES AND AUXILIARY STRUCTURES	5
Drainpipes	5
Clay tiles	5
Concrete tiles	6
Plastic drainpipes	7
Pipe accessories	8
End caps	8
Couplers	9
Reducers	9
Pipe fittings	10
Protection structures	10
Drain bridges	10
Rigid pipes	10
Inlets	10
Blind inlets	10
Surface inlets	13
Connection structures	13
Junction boxes	13
Manholes	13
Outlets	13
Gravity outlets	13
Pumped outlets	17
Special structures	17
Gradient reducers	17
Cleaning facilities	17
Structures for controlled drainage and subirrigation	19
3 ENVELOPE MATERIALS	21
Materials	21
Granular mineral envelopes	21
Organic envelopes	22
Synthetic envelopes	24
Specifications for drain envelopes	27
Specifications for gravel envelopes	27
Specifications for prewrapped envelopes	30
Availability and cost	36

---

	page
Review of local experience on drainage materials	37
Arid and semi-arid zones	39
Humid Tropics	39
Temperate zones	40
4 WATER FLOW INTO AND INSIDE THE DRAIN	43
Flow towards the drain	43
Entrance and approach flow resistance	45
Water flow into the drainpipe	48
The exit gradient	48
The critical hydraulic gradient	49
Hydraulic failure gradient	51
Entrance resistance of drainpipes	52
Plain drain	52
Drain with envelope	56
Drain with a less permeable surround	58
Discharge capacity of drainpipes	59
5 THE PROBLEM OF CLOGGING OF PIPES AND ENVELOPES	63
Mineral clogging	63
Processes in soils around drains	63
Pipe clogging	67
Chemical and biochemical clogging	68
Iron ochre	68
Lime and gypsum depositions	72
Manganese deposits	73
Sulphur precipitate	73
Iron sulphide	73
Penetration of roots into drainpipes	73
6 GUIDELINES TO PREDICT WHETHER AN ENVELOPE IS REQUIRED	75
Physical properties of the soil	76
Soil texture	76
Structural stability	78
Moisture content	80
Chemical properties of the soil	80
Cation Exchange Capacity	80
Soil salinity	81
Soil sodicity	81
Water quality	83
Irrigation water	83
Groundwater	83
Prediction Criteria	84
7 GUIDELINES FOR INSTALLATION AND MAINTENANCE OF DRAINAGE MATERIALS	85
Installation of subsurface drainage materials	85
Installation procedures	85

---

	page
Guidelines with respect to drainpipes	87
Guidelines with respect to envelopes	89
Maintenance of drain pipes	90
Jet flushing	90
Empirical experience with jetting in northwestern Europe	93
Guidelines for jetting	94
<b>8 RESEARCH ON DRAINAGE MATERIALS</b>	<b>97</b>
Relevant soil characteristics and envelope parameters	97
Laboratory assessment of envelope applicability	98
Sand tank models	98
Parallel flow permeameters	100
Guidelines for permeameter research	102
Field assessment of envelope applicability	104
Field research	104
Guidelines for field research	105
Recommendations for future research	108
Drain pipes	109
Drain envelopes	109
Soil properties	111
<b>9 STANDARDS FOR PIPES AND ENVELOPES</b>	<b>113</b>
Testing parameters for drainpipes	114
Clay and concrete pipes	114
Concrete pipes	114
Plastic pipes	114
Testing parameters for envelopes	115
Granular materials	115
PLMs and geotextiles	115
Geotextiles	115
North American Standards	115
European standards	116
<b>REFERENCES</b>	<b>119</b>
<b>ANNEX DRAFT EUROPEAN STANDARD ON CORRUGATED POLYVINYL CHLORIDE DRAINPIPES</b>	<b>131</b>

## List of tables

	page
1. Gradation relationships between soil and diameters of graded granular envelope material	29
2. Largest permissible gravel/aquifer size ratios	29
3. Fitted values for pipe sedimentation depth (mm) from a regression model, depending on effective opening size of the envelope pores, $O_{90}$ , and envelope category (thin or voluminous) for observations made at three experimental fields in The Netherlands	34
4. The relative cost of PLM envelopes, expressed as a percentage of the cost of the envelope plus a corrugated PVC pipe together as a prewrapped product, in The Netherlands in 1998. The cost of installation is not included. The $O_{90}$ size is specified within brackets	37
5. Drainage materials used in a number of countries	38
6. Applicability of the most popular prewrapped drain envelopes in The Netherlands	41
7. Entrance resistances and $r_{ef}/r_o$ -ratios of plain drainpipes	56
8. Ochre potential according to the Ford-method and the method of indicator strips	71
9. Problems with the infiltration rate of water into a soil as related to $SAR_{iw}$ and $EC_{iw}$ of irrigation water	83
10. Relation between pump pressure, nozzle pressure and discharge for a flexible hose with an inside diameter of 20 mm and a length of 300 m	92
11. Classification according to the 'approach flow head loss fraction'	107
12. Classification according to 'approach flow resistance' or 'approach flow head loss'	107
13. ASTM-standards for clay and concrete drainpipes	115
14. United States and Canadian standards for corrugated plastic pipes	116
15. European (EN) standard for geotextiles and geotextile-related products which can be useful when used as envelopes in agricultural drainage	117



---

## List of figures

	page
1. End caps	9
2. Couplers	9
3. Drainpipe reducer	10
4. Pipe fittings	11
5. Drain bridge	11
6. Use of rigid pipes to cross a road, a waterway or a row of trees	12
7. Blind inlet	12
8. Surface inlets	12
9. Junction boxes	14
10. Inspection chambers (manholes)	14
11. Gravity outlets	15
12. Drainage pump sump	16
13. Gradient reducers	16
14. Access pipe for cleaning laterals of a composite drainage system	18
15. Controlled drainage systems: (a) elbow and plug with riser; (b) plug with bypass; (c) sophisticated structure with crest board	18
16. Coconut fibre PLM envelope	23
17. PLM envelope made from polypropylene waste fibres (PP-300)	24
18. PP-450 envelope	24
19. PP-700 envelope	25
20. PS-1000 envelope	25
21. Typar envelope	26
22. Flow resistances towards a drain flowing at full capacity (a) and their corresponding head losses (b)	43
23. Approach flow and total head loss to evaluate drainage performance in experimental fields	45
24. Drain with or without envelope, disturbed trench backfill and undisturbed soil constitute the approach flow region	46

---

	page
25. Horizontal flow	49
26. Radial flow	49
27. Exit gradient $i_{ex}$ , expressed as the ratio $i_{ex}K/qL$ for radial flow as a function of the drain radius, $r_o$	50
28. Radial flow to (a) an ideal and (b) a real drain	53
29. Influence of a partly radial flow pattern on the entrance resistance of real drains	54
30. Possible boundaries between soil and drain openings	54
31. Theoretical flow towards an ideal drain surrounded by an envelope	56
32. Effective radii, $r_{ef}$ , for drains of different pipe radii, $r_o$ , and provided with four continuous longitudinal slits as a function of the envelope thickness $d_e$ for $\kappa_e = 10$	59
33. Natural filter	64
34. Contact erosion	64
35. Filter cake	65
36. Soil collapse	65
37. Example of a layered subsoil (left) and of a subsoil with vertically oriented macropores, that had developed at former root channels (right)	66
38. Image areas displaying drain envelopes and active macropores	66
39. Illustration of the heterogeneity of mineral clogging patterns as detected inside voluminous envelopes	67
40. Textural classes	76
41. Particle size distribution curves	77
42. Range of particle size distribution of soils that may cause clogging of drains	79
43. Jet flushing with a medium pressure unit	91
44. Cross section of a permeameter apparatus for evaluating soil-envelope interactions	101

## Foreword

Reliable subsurface drainage systems for groundwater table and salinity control are needed to maintain or enhance the productivity of irrigated lands and to contribute to the rural development of lowlands in the humid tropics. In addition, they continue to be important as a means of groundwater table control in some areas of the temperate zones. The selection of appropriate materials (i.e. pipes and envelopes) and their adequate installation and maintenance are essential for the proper and lasting performance of subsurface drainage systems. This was acknowledged in FAO Irrigation and Drainage Paper 9, *Drainage Materials*, published in 1972. At that time, the expertise concerning drainage materials came mainly from projects located in the temperate zones of northwestern Europe and the United States. Since then, valuable experience has also been gained in tropical countries that may be useful and, as such, should be made available to the professional communities. In the past two decades, substantial developments have been made in drainage engineering, specifically concerning installation techniques and materials. This progress has been achieved as a result of a great number of research projects and practical experience, also from irrigated lands. Hence, there was a need to update FAO Irrigation and Drainage Paper 9.

Field engineers and contractors who are in charge of new drainage projects need practical guidance for the selection and installation of drainpipes and envelopes. The selection of drainage materials, however, depends upon various factors, of which availability, durability and cost are of paramount importance. A procedure is required which allows engineers to predict whether the installation of envelopes is needed. Guidelines for selection must also consider the required specifications of the materials. In addition, guidelines must be available to help contractors in their assessment of whether or not available materials comply with the required specifications.

The purpose of this Paper is to provide this practical information to drainage engineers and contractors. The Paper is based on the current knowledge of water flow into drainpipes and envelopes, their properties and applicability. It also contains guidelines to assess the need for envelopes and for selection of the most appropriate envelope material, as related to local conditions. Guidelines for installation and maintenance of drainage materials as well as specifications and standards for such materials, which may be used in tender documents for implementation of subsurface drainage works, have also been included. In addition, it contains practical guidelines for the implementation of laboratory and field investigations to evaluate the performance of drainage materials.

## Acknowledgements

The authors are obliged to W.H. van der Molen (retired from Wageningen University, The Netherlands), L.S. Willardson (retired from the Utah State University, Logan, USA) and J. Cavelaars (retired from Arcadis Euroconsult, Arnhem, The Netherlands) for their willingness to review the manuscript. Their suggestions, annotations and contributions to improve both the layout, the technical content and the readability are highly appreciated.

The authors also wish to acknowledge H. Wolter, Director of the Land and Water Development Division of FAO for his support during the preparation of this *Irrigation and Drainage Paper*.

Special tribute is paid to P. Thévenet, Director Wavin, Varennes sur Allier, France, and convenor of Working Group 18 of CEN/TC 155, for his authorization to include the draft European standard on corrugated polyvinyl chloride drainpipes as an annex to this Paper.

Acknowledgement is given to Horman Wrapping BV, The Netherlands, for their permission to use Figures 16 to 21.

Thanks are also expressed to Ms C.D. Smith-Redfern for formatting text, figures and tables to the final camera-ready form.

## List of symbols

Symbol	Description	Dimension
$A$	Area of cross-section ( $m^2$ )	$L^2$
$C_u$	Coefficient of uniformity	-
$CEC$	Cation Exchange Capacity (meq/100 g)	-
$c_o$	Cohesion (Pa)	$ML^{-1}T^{-2}$
$D_x$	Particle diameter of the $x\%$ size of the granular envelope material ( $\mu m$ )	$L$
$D_5$	Particle diameter of the 5% size of the granular envelope material ( $\mu m$ )	$L$
$D_{15}$	Particle diameter of the 15% size of the granular envelope material ( $\mu m$ )	$L$
$D_{30}$	Particle diameter of the 30% size of the granular envelope material ( $\mu m$ )	$L$
$D_{50}$	Particle diameter of the 50% size of the granular envelope material ( $\mu m$ )	$L$
$D_{100}$	Particle diameter of the 100% size of the granular envelope material ( $\mu m$ )	$L$
$d$	Internal pipe diameter (cm)	$L$
$d_e$	Envelope thickness (cm)	$L$
$d_x$	Particle diameter of the $x\%$ size of the soil material ( $\mu m$ )	$L$
$d_{10}$	Particle diameter of the 10% size of the soil material ( $\mu m$ )	$L$
$d_{15}$	Particle diameter of the 15% size of the soil material ( $\mu m$ )	$L$
$d_{50}$	Particle diameter of the 50% size of the soil material ( $\mu m$ )	$L$
$d_{60}$	Particle diameter of the 60% size of the soil material ( $\mu m$ )	$L$
$d_{85}$	Particle diameter of the 85% size of the soil material ( $\mu m$ )	$L$
$d_{90}$	Particle diameter of the 90% size of the soil material ( $\mu m$ )	$L$
$dh$	Small increment in hydraulic head (m)	$L$
$dl$	Small increment in length (m)	$L$
$dr$	Small increment in radial distance (m)	$L$
$EC$	Electrical Conductivity ( $dS m^{-1}$ )	$T^3I^2M^{-1}L^{-3}$
$EC_e$	Electrical Conductivity of a soil paste saturated with water up to the liquid limit ( $dS m^{-1}$ )	$T^3I^2M^{-1}L^{-3}$
$EC_s$	Electrical Conductivity of the soil solution at field capacity ( $dS m^{-1}$ )	$T^3I^2M^{-1}L^{-3}$
$EC_{gw}$	Electrical Conductivity of the groundwater ( $dS m^{-1}$ )	$T^3I^2M^{-1}L^{-3}$
$EC_{iw}$	Electrical Conductivity of the irrigation water ( $dS m^{-1}$ )	$T^3I^2M^{-1}L^{-3}$
$ESP$	Exchangeable Sodium Percentage	-
$H$	Height of sand model tank (m)	$L$
$h$	Head loss (m)	$L$

Symbol	Description	Dimension
$h_e$	Entrance head loss (m)	L
$h_h$	Horizontal head loss (m)	L
$h_r$	Radial head loss (m)	L
$h_t$	Total head loss (m)	L
$h_v$	Vertical head loss (m)	L
$h_{ap}$	Approach flow head loss (m)	L
$I_p$	Plasticity index of the soil	-
$i$	Hydraulic gradient for flow in soil	-
$i_c$	Critical hydraulic gradient	-
$i_f$	Hydraulic failure gradient	-
$i_{ex}$	Exit gradient	-
$K$	Hydraulic conductivity (m d <sup>-1</sup> )	LT <sup>-1</sup>
$K_e$	Hydraulic conductivity of the envelope (m d <sup>-1</sup> )	LT <sup>-1</sup>
	Hydraulic conductivity of the loosened soil in the drain trench (m d <sup>-1</sup> )	LT <sup>-1</sup>
$K_h$	Horizontal hydraulic conductivity of the soil (m d <sup>-1</sup> )	LT <sup>-1</sup>
$K_r$	Radial hydraulic conductivity of the soil (m d <sup>-1</sup> )	LT <sup>-1</sup>
$K_s$	Hydraulic conductivity of the soil (m d <sup>-1</sup> )	LT <sup>-1</sup>
$K_v$	Vertical hydraulic conductivity of the soil (m d <sup>-1</sup> )	LT <sup>-1</sup>
$K_{ap}$	Hydraulic conductivity of the approach flow zone (m d <sup>-1</sup> )	LT <sup>-1</sup>
$k_M$	Reciprocal parameter of Manning's roughness coefficient (m <sup>1/3</sup> s <sup>-1</sup> )	L <sup>1/3</sup> T <sup>-1</sup>
$L$	Drain spacing (m)	L
	Length of a sand model tank (m)	L
$LF$	Leaching Fraction	-
$n$	Manning's roughness coefficient (s m <sup>-1/3</sup> )	T L <sup>-1/3</sup>
	Factor of concentration of the irrigation water in the soil	-
$O_{90}$	Pore diameter of the 90% opening size of the envelope material (μm)	L
$p$	Ratio of full to sectorial radial flow	-
$Q$	Discharge (m <sup>3</sup> s <sup>-1</sup> )	L <sup>3</sup> T <sup>-1</sup>
$q$	Specific discharge (m d <sup>-1</sup> )	LT <sup>-1</sup>
$r$	Radius of a circular equipotential (m)	L
	Distance from drain center (m)	L
$r_e$	Radius of the soil-envelope interface (m)	L
$r_o$	Radius of the ideal drain (m)	L
	Outer drain radius (m)	L
$r_{ef}$	Equivalent or effective radius (m)	L

Symbol	Description	Dimension
$S$	Pitch length of corrugated pipe (m)	L
$SAR$	Sodium Adsorption Ratio ( $\text{meq}^{1/2} \text{l}^{-1/2}$ )	$\text{M}^{1/2} \text{L}^{-3/2}$
$SAR_e$	Sodium Adsorption Ratio of a soil paste saturated with water up to the liquid limit ( $\text{meq}^{1/2} \text{l}^{-1/2}$ )	$\text{M}^{1/2} \text{L}^{-3/2}$
$SAR_s$	Sodium Adsorption Ratio of the soil solution at field capacity ( $\text{meq}^{1/2} \text{l}^{-1/2}$ )	$\text{M}^{1/2} \text{L}^{-3/2}$
$SAR_{gw}$	Sodium Adsorption Ratio of the groundwater ( $\text{meq}^{1/2} \text{l}^{-1/2}$ )	$\text{M}^{1/2} \text{L}^{-3/2}$
$SAR_{iw}$	Sodium Adsorption Ratio of the irrigation water ( $\text{meq}^{1/2} \text{l}^{-1/2}$ )	$\text{M}^{1/2} \text{L}^{-3/2}$
$s$	Hydraulic gradient for pipe flow	-
$TDS$	Total Dissolved Solids ( $\text{mg l}^{-1}$ )	$\text{ML}^{-3}$
$W$	Flow resistance ( $\text{d m}^{-1}$ )	$\text{TL}^{-1}$
	Width of a sand model tank (m)	L
$W_e$	Entrance flow resistance ( $\text{d m}^{-1}$ )	$\text{TL}^{-1}$
$W_h$	Horizontal flow resistance ( $\text{d m}^{-1}$ )	$\text{TL}^{-1}$
$W_r$	Radial flow resistance ( $\text{d m}^{-1}$ )	$\text{TL}^{-1}$
$W_t$	Total flow resistance ( $\text{d m}^{-1}$ )	$\text{TL}^{-1}$
$W_v$	Vertical flow resistance ( $\text{d m}^{-1}$ )	$\text{TL}^{-1}$
$W_{ap}$	Approach flow resistance ( $\text{d m}^{-1}$ )	$\text{TL}^{-1}$
$W_{DS}$	Mass of oven-dried soil sample (g)	M
$W_{LL}$	Mass of soil sample at liquid limit (g)	M
$W_{PL}$	Mass of soil sample at plastic limit (g)	M
*	Subscript $v$ (vertical), $h$ (horizontal), $r$ (radial), $e$ (entry) or $t$ (total)	-
$\alpha$	Flow resistance factor	-
$\alpha_e$	Entrance flow resistance factor	-
$\alpha_h$	Horizontal flow resistance factor	-
$\alpha_r$	Radial flow resistance factor	-
$\alpha_t$	Total flow resistance factor	-
$\alpha_v$	Vertical flow resistance factor	-
$\alpha_e^*$	Flow resistance depending on the sector area with radial flow	-
$\alpha_e'$	Entrance resistance factor of the drainpipe itself when surrounded by an envelope	-
$\alpha_{ap}$	Approach flow resistance factor	-
$\alpha_{e,e}$	Entrance resistance factor of both drain and surrounding envelope	-
$\alpha_{(e,e)W}$	Entrance resistance factor of both drain and surrounding envelope according to Widmoser (1968)	-
$\beta$	Angle of sectorial radial flow (rad)	-
$\phi$	Angle of internal friction or shearing resistance (rad)	-

<b>Symbol</b>	<b>Description</b>	<b>Dimension</b>
$\kappa_e$	Hydraulic conductivity ratio of envelope and surrounding soil	-
$\sigma_e$	Effective stress of the soil particles or intergranular stress (Pa)	$ML^{-1}T^{-2}$
$\tau_f$	Shearing resistance per unit area (Pa)	$ML^{-1}T^{-2}$
$\Delta h$	Increment in hydraulic head (m)	L
$\Delta l$	Increment in length (m)	L



# Chapter 1

## Introduction

### HISTORY

When drainage for agriculture began approximately 9000 years ago in Mesopotamia, pipes were non-existent (Van Schilfgaarde, 1971). Subsurface drainage was most likely implemented by gravel and stones, or permeable, voluminous substances like e.g. bundles of small trees and shrubs tied together in the bottom of a trench. The first drainpipes are approximately 4000 years old; they were discovered in the Lower Indus River valley (Ami, 1987). In Europe, the first subsurface drainage systems were installed at the beginning of the Christian era. Subsurface drainage, however, was more or less forgotten in the centuries that followed.

Drainage systems reappeared in England around the year 1544 when the Dutch began to export to England the skill of their engineers, who were respected 'drainers' and 'dykers'. The first Dutchman to undertake drainage work in England was Cornelius Vanderdelf, later followed by other famous engineers like Cornelius Vermuyden and Joos Croppenburgh, in the beginning of the 17th century (Chapman, 1956). Soon afterward, ridge tiles were introduced as drains in Scotland and on the European mainland. Ridge tiles must be regarded as the predecessors of tiles, hence the name. The general stages of development were simple horseshoe drains, horseshoe drains on sole plates, flat-bottomed D-shaped drains, and finally round pipes. The invention of the tile extruder in England in 1840 strongly enhanced the rate of land drainage in Europe. Nearly two centuries ago, pipe drainage was introduced in the United States. During the subsequent period, clay tiles were machine manufactured and laid by hand. Around 1960 mechanical installation became widespread. The introduction of perforated plastic pipes for drainage in the 1960s increased the effectiveness, efficiency and economics of installation.

Drainpipes have been made from wood boards or box drains, bricks, and horseshoe shaped ceramic tile, circular clay tile, concrete tile, bituminized fibre perforated pipe, perforated smooth plastic pipe to corrugated plastic pipe. Currently, corrugated pipes are frequently used, although clay and concrete pipes are still used as well. Their application is determined by economic factors in the region concerned.

Some significant developments in agricultural drainage are summarized by Schwab and Fouss (1999). The following first applications are, in chronological order:

- Installation of the first drain tile in the United States (1835).
- Invention of a tile extruder in England (1840).
- Manufacturing of the first drainpipe from sand and cement in the United States (1862).
- Use of trenching machines (1880).
- Introduction of smooth PE pipe in the United States (1948).
- First application of smooth, rigid PVC pipe in The Netherlands (1959).
- Introduction of the first flexible PVC pipe in Germany (1963).

- Installation of the first corrugated, flexible PE pipe in the United States (1965).
- Development of drain ploughs (1969).
- First standard for PE corrugated pipe, i.e. ASTM F405 (1974).
- Drafting of a standard for prewrapped envelope in The Netherlands (1981).
- The first draft ISO standard for corrugated PVC pipes (ISO/DIS 8771, 1985).
- Introduction of draft EN standard for PVC corrugated pipes (CEN/TC155/WG18, 1994).

More historical data concerning drainage materials may be found in Weaver (1964) and Van Someren (FAO, 1972).

### CONTEMPORARY DRAINAGE MATERIALS

Contemporary drainage materials may be classified into drainpipes and their accessories, envelopes and auxiliary drain structures. Design criteria for drainpipes are now well established and unambiguous, both with respect to pipe size, geometry and perforation pattern, as well as to pipe material.

When a subsurface drain is installed, some soils may require measures to protect the drainpipe from soil particle entry. Due to the drag force of the water, soil particles or aggregates may be carried into the pipe through the perforations in the pipe wall. This process can never be prevented completely, but it may substantially be slowed down, or stopped by use of external porous material around the pipe. The porous device, designed to do this is called 'drain envelope', but has often erroneously been referred to as a 'drain filter'. The functioning of a filter is such that it retains soil material as a result of which it may become blocked or clogged, or causing the surrounding soil to become clogged. A good 'drain envelope', on the contrary, restricts sediment inflow, provides material of high hydraulic conductivity and structural stability close to the drain, and does not clog with time.

The design of *conventional* envelopes is not a major problem. These envelopes, which belong to the *first generation of envelopes*, consist of gravel, broken shells or loose organic materials like peat litter. Design criteria for mineral granular envelopes have gradually been developed in the United States (Willardson, 1974). Sound design criteria for traditional granular drain envelopes (gravel and coarse sand) are available and have been applied successfully in practice (Terzaghi and Peck, 1961).

In many areas, properly graded gravel envelope material is scarce or non-existent, and then it constitutes the principal cost of drain installation. Moreover, handling and placement of gravel envelopes around the drainpipe is a difficult operation, leading to high installation costs. This has led to a search for lightweight substitutes for gravel envelopes.

Alternative envelope materials were usually composed of organic fibres such as those found in crop residues. Peat envelopes, already mentioned, were applied successfully for many years and were traditional in areas where gravel was expensive. In further attempts to bring down the cost of drainage systems and to simplify mechanical installation, the *second generation of envelopes*, namely cover materials in strip form, gradually replaced loose organic materials. A roll of such a strip could be carried on a trencher and rolled out over the pipe as it was being installed. The first materials produced in strip-form were fibrous peat, flax straw and coconut fibres. Meanwhile, high quality peat litter, a traditional envelope, became scarce, prompting a search for alternatives. In the 1960s, strips of glass fibre sheet were also used, being affordable and easy to handle.

Soon after the introduction of corrugated pipes in 1962, the use of cover materials in strip-form was abandoned. In Europe, fibrous organic envelopes were developed which could be wrapped around corrugated pipes prior to installation. Pipe and envelope could then be installed as a composite product, namely a wrapped drain. This reduced the installation costs by roughly 50 percent.

While the use of organic envelopes has become widespread, their proneness to microbiological decomposition was a disadvantage. Therefore, the youngest *and third generation of envelopes*, synthetic envelopes, has gained popularity quite rapidly. Their application is commonplace in North America and Europe, and is growing fast in countries like Egypt, Pakistan, and India. Synthetic envelopes are either strips of geotextiles wrapped around the drainpipe, or loose synthetic fibre wrappings. Most loose synthetic fibre wrappings are manufactured from recycled material, like polypropylene waste fibres from the carpet industry.

#### **PROBLEMS WITH DRAINAGE MATERIALS**

Installing drains in the traditional way, which is by manual labour, cannot be easily done under adverse conditions such as shallow groundwater tables or general wetness. This restriction usually prevented poor drainage performance and ensured a long service life for manually installed systems. Since the introduction of mechanization the installation speed has risen drastically and control of the quality of the work (e.g. grade line accuracy) became more difficult, particularly after the introduction of the flexible corrugated pipe. Installation under adverse conditions also became possible and proved hard to monitor, because contractors and constructing agencies try to keep their machines working as long as possible, due to the high fixed costs of installation machinery. The introduction of laser grade control in 1965 greatly improved the precision of installation.

The mechanization of drain installation as well as the introduction of new types of drain envelopes has led to cost reduction on the one hand, but also to hitherto virtually unknown problems. Some of these problems were introduced by drain installation in very wet soils, and by the introduction of new types of envelopes not suitable for use in all types of soils.

Application of a drain envelope largely depends on physical soil properties. In practice however, availability and cost strongly affect the selection process. Notably in arid areas, where drainage systems are installed for the control of waterlogging and salinization, the need to find affordable alternatives for potentially excellent yet expensive gravel envelopes has become increasingly urgent. The considerable research and practical experience gained from the 1960s to the late 1980s have provided guidelines for envelope design and for selection of materials for different soils.

#### **SCOPE OF THIS PUBLICATION**

The objective of this new FAO Irrigation and Drainage Paper on *Materials for subsurface land drainage systems* is to assess and discuss the existing knowledge on drainage materials. The emphasis in this publication is on drainpipes and envelopes. It contains guidelines for design, selection and installation, and standard specifications to be used in tender documents for

implementation of subsurface drainage works. Maintenance of drain lines is discussed as well. An effort has been made to seriously investigate the existing criteria, and to detect their similarities and contradictions. This investigation has led to a set of practical application criteria for envelope materials.

The current knowledge on drainage materials and their suitability should be appealing to, and applicable by engineers and contractors. This is not a 'drainage materials handbook' for drainage specialists. It is an *application* guide, primarily developed for the benefit of design engineers and contractors.

In this publication the following issues are covered:

- a review of existing subsurface drainpipes and some auxiliary structures (Chapter 2);
- an evaluation of the properties and suitability of drain envelopes for specific applications as derived from observations in pilot areas and from analogue simulation in laboratories (Chapter 3);
- an analysis of the existing knowledge on water flow into envelopes and drains (Chapter 4);
- guidelines to assess the need for envelopes, and to select the most appropriate envelope material, depending on local conditions (Chapters 5 and 6);
- guidelines for installation and maintenance of drainage materials (Chapter 7);
- the need for research on drainage materials (Chapter 8); and
- a review and assessment of existing standards and specifications for drainpipes and envelopes which are currently used (Chapter 9 and Annex).

## Chapter 2

# Drainage pipes, accessories and auxiliary structures

### DRAINPIPES

For many years, clay and concrete pipes were predominantly used until the introduction of smooth plastic drainpipes around 1960. Soon afterwards corrugated plastic pipes came into common use.

Clay, concrete and plastic pipes give satisfactory results if they meet quality standards and are properly installed. Collector pipes are made of concrete or plastic. Pipes that are manufactured from the latter type of material are not yet competitive for diameters exceeding 200 mm. However, perforated corrugated plastic collectors, wrapped with a sheet envelope, may be installed comparatively easily if the surrounding soil consists of quicksand or has other “quick” properties. Once installed, the collector can act as a drain, cancelling the quick condition of the soil and facilitating the connection of laterals and/or the installation of manholes.

In theory, there are valid considerations to select specific types of drainpipe. In practice, selection is mostly based on cost comparison and on local availability. In addition, the following observations may be relevant (Schultz, 1990):

- If all types of pipe are available, the use of corrugated plastic pipes has distinct advantages (Section *Plastic drainpipes*).
- If pipes are not locally available, local manufacture of concrete pipes is the most straightforward and the easiest to implement. It requires less skill than manufacturing other types of pipe, and is already economical on a small scale. Plastic pipes occupy an intermediate position: local manufacturing from imported raw material is indeed possible for reasonably large quantities.
- Plastic pipes are particularly suited for machine installation. They have the advantage that their performance is the least affected by poor installation practice.
- The manufacturing cost of small diameter pipe (i.e. < 100 mm) is usually of the same order for clay tiles, concrete tiles and plastic. For large diameter pipes, however, concrete is usually the cheapest and plastic the most expensive.

### Clay tiles

Clay tile may be either porous or glazed. Pipe sections are abutted against each other and water enters through the joints. The porous type usually has butt joints, but it may also have flanges (also referred to as ‘collars’ or ‘bell joints’). The latter type of tile is more expensive, and the extra cost is only justified in very soft soils. Good quality pipes are adequately baked and are free from cracks and blisters. Clay tile with cracks or other visible shortcomings and badly formed pipes should not be used.

Standard drainpipe sizes are 50, 65, 75, 80, 100, 130, 160, and 200 mm inside diameter. In the United Kingdom, the nominal minimum size is 75 mm inside diameter, which has a generous capacity to carry water, and thus diameter is rarely a significant design consideration when using clayware pipes for laterals. The wall thickness varies from 12 to 24 mm, and may be expressed as  $0.08d + 8$  mm, where  $d$  is the inside pipe diameter in mm. Current clay tiles have lengths of 300 or 333 mm, yet in some countries greater lengths are available. In Germany, clay tiles were provided with longitudinal grooves at the outside wall, facilitating water flow alongside the drain in combination with envelope materials.

Clay tile is very durable and highly resistant to weathering and deterioration in aggressive soil conditions e.g. in soils containing sulphates and corrosive chemicals. It can be used in almost all circumstances. Clay tile is lighter than concrete and has excellent bearing strength. It is however fragile (especially the German grooved type), and must be handled with care. Clay tiles require a good deal of manual handling, although manufacturers have improved this by various methods of bulk handling.

Manufacturing of clay tiles requires a great deal of skill and a well-equipped plant. The major quality features are straight joints, absence of cracks and homogeneity of the raw material (well-mixed clay). The maximum water absorption rate after being immersed in water for 24 hours should be less than 15 percent of the weight of the tile. The weight of 1 000 tiles should exceed certain minimum values, e.g. 1 400 kg for 60 mm diameter pipe and 2 000 kg for 80 mm diameter pipe.

In some areas, clay and concrete tiles are still laid manually in a hand dug or mechanically excavated trench. These pipes may be covered with bulky materials or with 'envelopes' in strip form.

Clay tiles should be installed in such a way that a perfect alignment between individual pipes is obtained. The maximum gap between individual pipes may not exceed 3 mm, except for sand where it should be not more than  $2d_{85}$ , i.e. the particle size for which 85 percent of the soil particles on dry weight basis have a smaller diameter.

### **Concrete tiles**

Concrete tile has been used on a large scale, e.g. in Egypt, Iraq and other countries. It is used if clay tile is not available, or if greater diameters must be applied. Concrete pipes are used mostly in medium to large sizes, with inside diameters of 100, 150 and 200 mm and up, and section lengths of 0.60, 0.91, 1.22 and 2.40 m. Tile over 300 mm inside diameter is usually reinforced. Butt joints are common.

The manufacture of concrete tiles is much simpler than that of clay tiles. Pipes should be well formed, finished, free from cracks and chips, and properly cured.

Concrete pipes should be used only when soil and groundwater analyses have established that conditions are suitable for their use. Pipes made with ordinary cement are liable to deteriorate in acidic and high sulphate soils, and by water carrying certain alkali salts or other chemicals. Concrete pipes should not be used at locations where industrial waste or house refuse has been collected. Special high sulphate-resistant cements and high density concrete should be used to resist chemical attack (e.g. by acids or sulphates).

Concrete pipes may disintegrate slowly from weathering, and are subject to erosion from fast flowing water carrying abrasive material. However, under a wide range of conditions, a permanent installation is lasting and justified.

## Plastic drainpipes

The main advantage of plastic pipes over clay and concrete pipes is their low weight per unit length, greatly reducing transportation cost. An additional cost-saving factor is the reduced need for the labour, required for installation.

Smooth plastic pipes were made of rigid polyvinyl chloride (PVC) and were provided with longitudinal slits to permit water entry. Smooth plastic pipes have never found a widespread use because they were rapidly superseded by corrugated pipes, that became available in 1963. They were so successful that they gradually started to replace clay and concrete pipes. This process is still continuing in various countries. The corrugated shape of the wall makes the pipe not only flexible, but also more resistant to compression than the smooth pipe, for the same quantity of raw material.

The introduction of corrugated pipe was a milestone in the history of agricultural drainage. This flexible pipe is very well suited for mechanized installation. Hence, the installation costs are significantly reduced. In addition, corrugated pipe has facilitated the development of trenchless installation techniques.

The switch from clay and concrete pipes to corrugated plastic pipes was expected because corrugated plastic pipes were advantageous, viz.:

- Light weight makes handling easier, even for great lengths.
- Long, continuous length eases handling, gives less alignment problems, and reduces stagnation of pipe supply resulting in a high installation rate for drainage machines.
- Flexibility and coilability facilitate handling, transportation and installation.
- Greater and more uniformly distributed perforation area, facilitating access of water.
- Easy wrapping with envelope materials.
- Safer implementation without too wide joints or misalignment.
- Less labour intensive and consequently lower labour cost for manufacture, handling, transportation and installation.
- Inert to all common soil chemicals.

Corrugated pipes also have disadvantages, compared to clay and concrete pipes:

- Vulnerability to deterioration from UV-radiation when exposed to sunlight for long periods, especially if made of PVC.
- Increased brittleness at low temperatures.
- Increased deflection risk at high temperatures and excessive stretch during installation.
- Lower deflection resistance under permanent load.
- Risk of collapse under sudden load, e.g. by trench wall caving or stones.
- Smaller transport capacity for the same inner diameter because of corrugation roughness.
- Not fire resistant.
- Not easy to relocate in the field with a tile probe without damaging the pipe.

Corrugated plastic drains are made of PVC, high-density polyethylene (PE) and polypropylene (PP). Preference of one of these materials is based on economic factors. In Europe, corrugated drains are mainly made of PVC except for the United Kingdom, where they are made of PE and a minority of PP. In the United States and Canada, most drainpipes are made of PE, largely because of the low price of the raw material. Good quality pipes can be made of both PVC and PE although these raw materials have different physical properties:

- The lower stiffness of PE means that pipes may be easily deformed under load, especially at temperatures approaching 40°C, and if they are subjected to longitudinal stress.

- PVC pipes are more susceptible to UV-radiation and become brittle at exposure; storage of unprotected pipes in the open should therefore be avoided.
- PVC pipes are more brittle at low temperatures than PE pipes; PVC pipes should not be installed at outside temperatures below 3°C because the risk that cracks will be formed is too high.
- PVC softens at 80°C and drainpipes will deform when exposed to such temperature. Especially in arid and semiarid areas, special care shall be taken to prevent such storage conditions.
- PVC has some environmental disadvantages: it forms hydrochloric acid when burnt.

In northwest Europe, PP pipes have been introduced for agricultural purposes. They are not widely used, but they are quite suitable for application in greenhouses, because they are heat resistant and tolerate disinfection of soils by steam vapour.

*European* pipe sizes usually refer to outside diameter. Standard outside diameters are 40, 50, 65, 80, 100, 125, 160 and 200 mm. Larger diameters are available as well. *North American* pipe sizes refer to inside diameters, which are 102, 127, 152, 203, 254, 305, 381, 457 and 610 mm. The inside diameter is normally 0.9 times the outside diameter. Corrugated plastic pipes of not too large a diameter (up to 250 mm) are delivered in coils. Larger diameter pipes are supplied in lengths of 6 m.

Water enters corrugated pipes through perforations, which are located in the valleys of the corrugations. Elongated openings or 'slots' are common, yet circular openings may be found as well. The perforations may have a diameter or slot width usually ranging between 0.6 to 2 mm. The length of the slots is approximately 5 mm, but sawn slits of larger diameter pipes may be longer. The perforations should be evenly distributed over the pipe wall, usually in at least four rows with a minimum of two perforations per 100 mm of each single row. In Europe, the perforation area should be at least 1200 mm<sup>2</sup> per metre of pipe.

Machine installation of corrugated plastic drainpipes is very straightforward. Smaller diameter pipes are usually carried on a reel on the machine and wound off while the installation proceeds. Larger diameter pipes are mostly laid out in the field and guided through the machine. A thorough control of the pipes and a careful installation is nevertheless always necessary to prevent pipe damage and longitudinal stretching. Regular quality control of corrugated plastic pipes is very important. The impact of sudden loads, simulating trench wall caving on the pipe at temperatures corresponding to the ambient installation temperature should be part of a testing programme.

## **PIPE ACCESSORIES**

Subsurface drainage systems require accessories and special structures such as pipe fittings (couplers, reducers, junctions, end caps), gravity or pumped outlets, junction boxes, inspection chambers (manholes), drain bridges, non-perforated rigid pipes, blind inlets, surface inlets, controlled drainage or subirrigation facilities, and cleaning provisions. Some fittings are made by pipe manufacturers, others are manufactured by specialized companies, and others are fabricated on the spot.

### **End caps**

End caps prevent the entrance of soil at the upstream drain-end opening. They can be made of the corresponding pipe material but any other durable flat material can be used for this purpose as well (Figure 1).



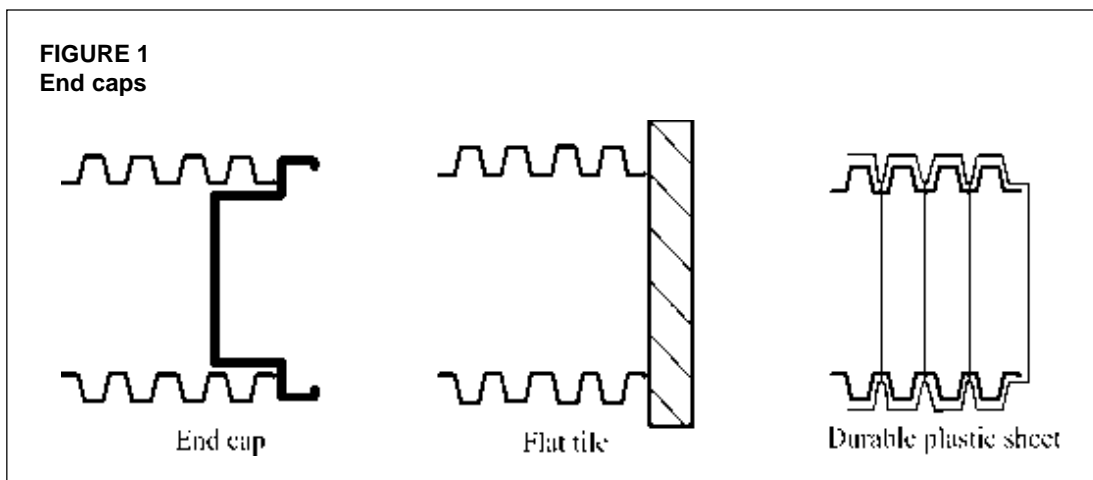

### Couplers

Corrugated pipes generally have external 'snap-on' couplers to connect pipes of the same diameter. Alternatively, a piece of pipe of the same diameter that is split for easy placing around both pipe ends, and firmly wrapped with tape or wire to keep it in place during installation, can be used instead (Figure 2a). Internal couplers (Figure 2b) can be used with the trenchless technique to prevent separation of connected pipes when passing through the pipe feeder device (Schwab and Fouss, 1999). Pipes can also be connected internally by making a slit in the end of the upstream pipe and forming a cone that is pushed into the end of the downstream pipe. Such connections are not very reliable and do impede the discharge of water and suspended solids.

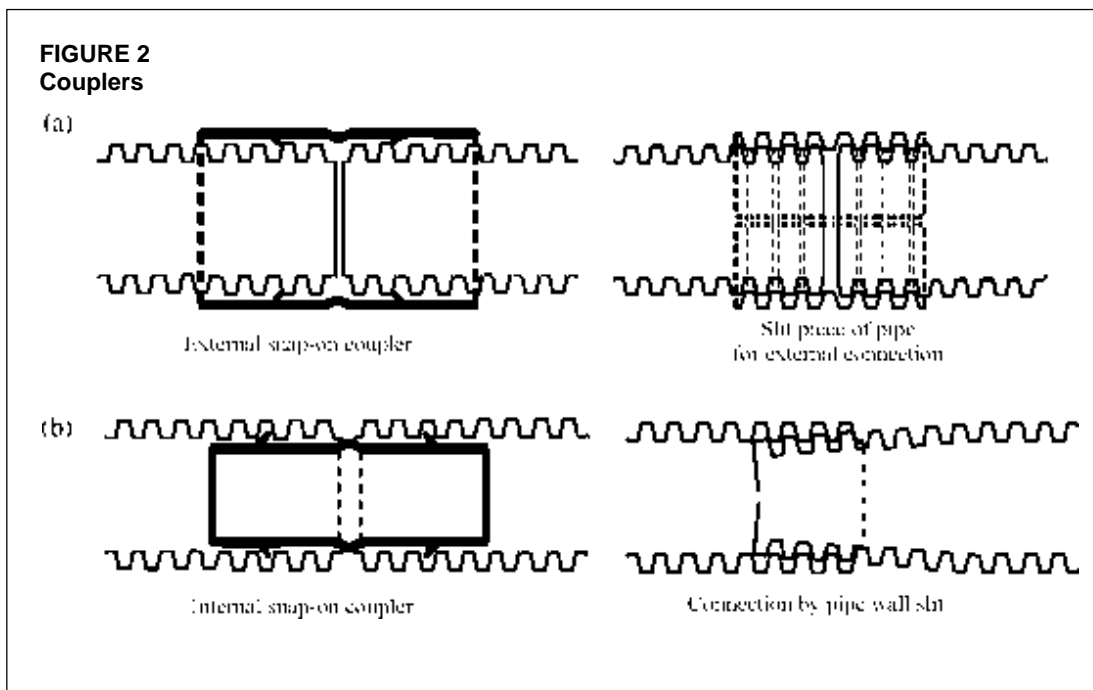

### Reducers

Reducers connect two pipe ends of different diameters (Figure 3).

### Pipe fittings

A wide range of pipe fittings, made of various raw materials, is commercially available for all kinds of pipes. Fittings for clay, concrete and corrugated plastic pipes are generally made by the various pipe manufacturers and therefore they are mostly not interchangeable.

Cross, T and Y-pieces connect laterals or collectors with collectors (Figure 4a). Many fittings are fabricated with multiple sizes at the ends (Figure 4b) facilitating the connection of various sizes of collectors and laterals (Schwab and Fouss, 1999). The end sides of the fittings are cut off, or adapted by removing some parts in the field to attach to the appropriate diameter. Simple connections with elbows and T-pieces on top of the collector are nowadays used to connect laterals with collectors (Figure 4c).

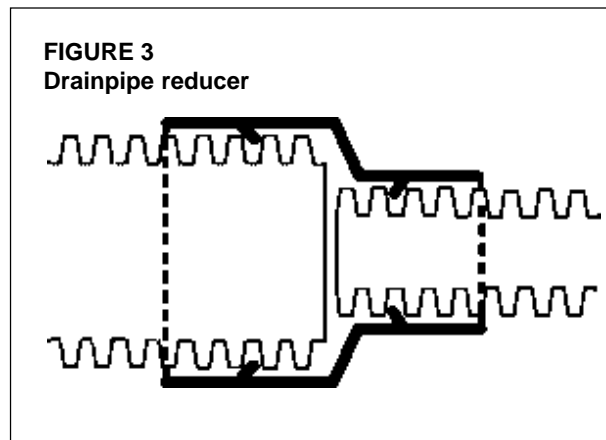

### PROTECTION STRUCTURES

#### Drain bridges

The undisturbed natural soil in which the pipes are laid normally has enough strength to support the pipe. However, when the drain crosses a soft spot where the soil has not yet settled, e.g. a filled-in former ditch, drain bridges should be used to maintain the level of the drain during settlement of the soil. Drain bridges can be made of timber blocks on which the drain is laid or of a continuous length of solid, rigid pipe (see Section *Rigid pipes*) surrounding the drain (Figure 5).

#### Rigid pipes

Drainpipes can be connected to or slid into a rigid, reinforced concrete, plastic or coated steel pipe where they have to cross a road, a waterway, a gutter, unstable soil (see Section *Drain bridges*), a row of trees to prevent roots from growing into the pipes, or other obstacles (Figure 6).

### INLETS

#### Blind inlets

Blind inlets are intended to drain stagnant pools, while sediments are intercepted. They consist of a trench above a drain that is filled with porous material (Figure 7). Durable material, such as stones, gravel and coarse sand is preferred as trench backfill. The gradation may vary from finer material at the surface to coarser with depth, although the trench can also be filled with one suitable porous material. The advantage of blind inlets is the initial low costs and the lack of interference with tillage operations. However, in general the use of blind inlets has been unsatisfactory because they tend to clog at the surface with fine soil particles and other sediments.

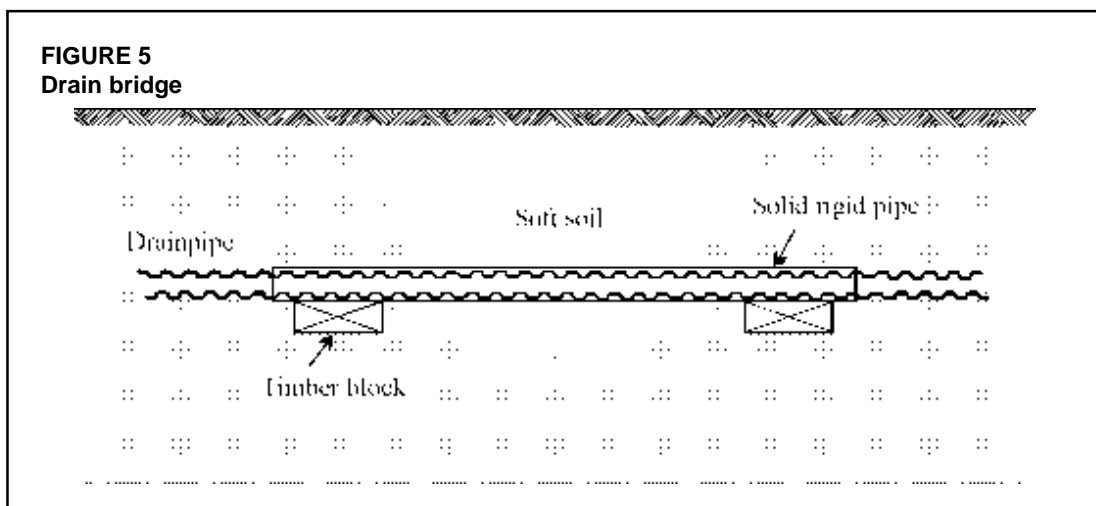
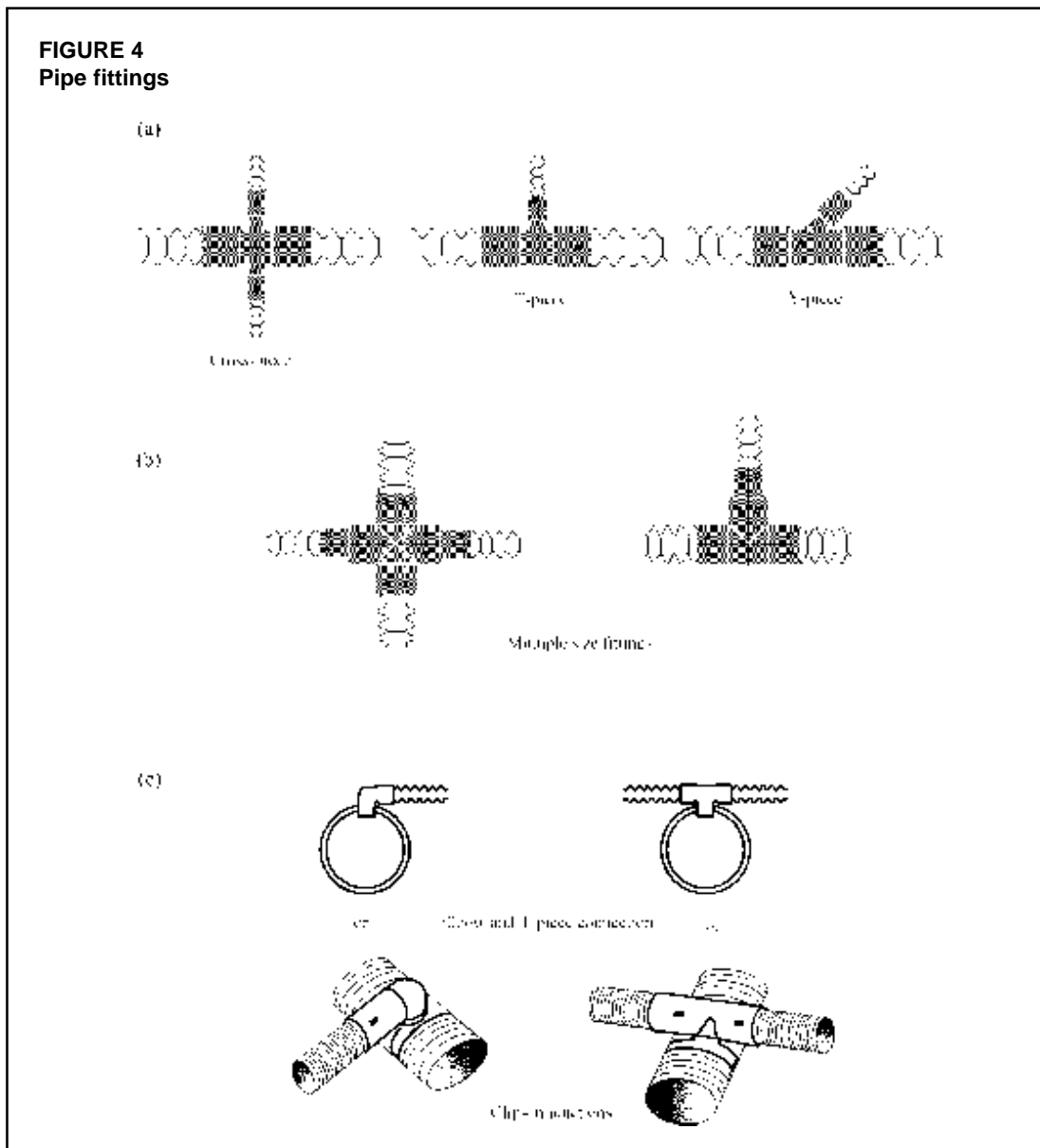

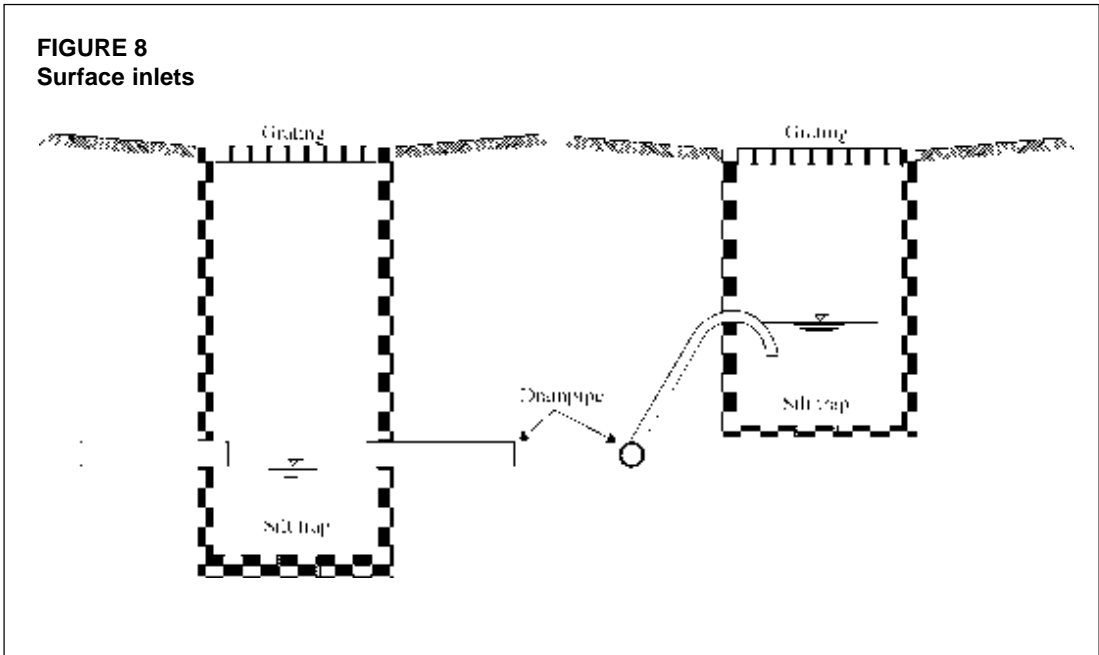
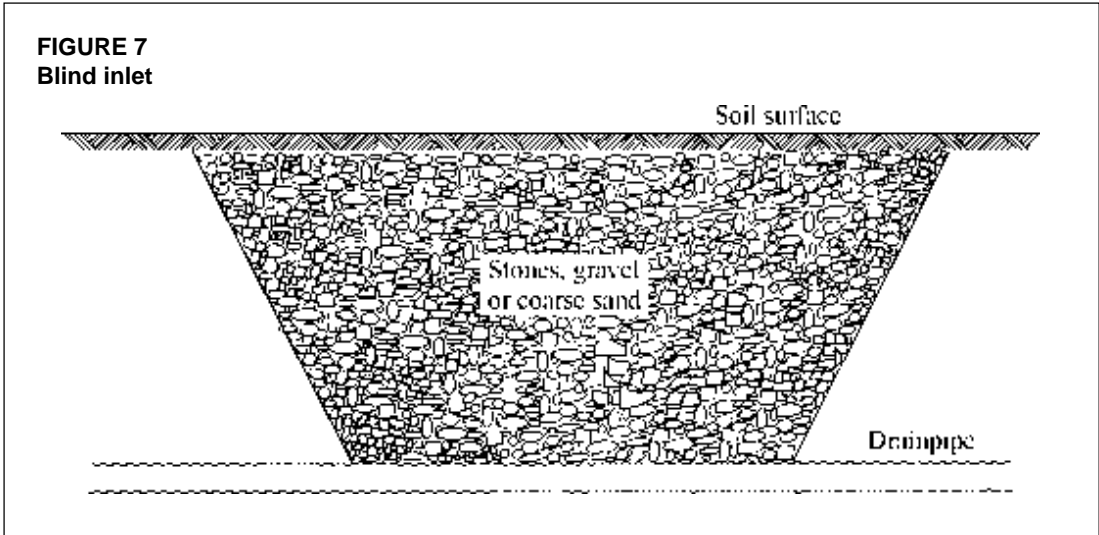
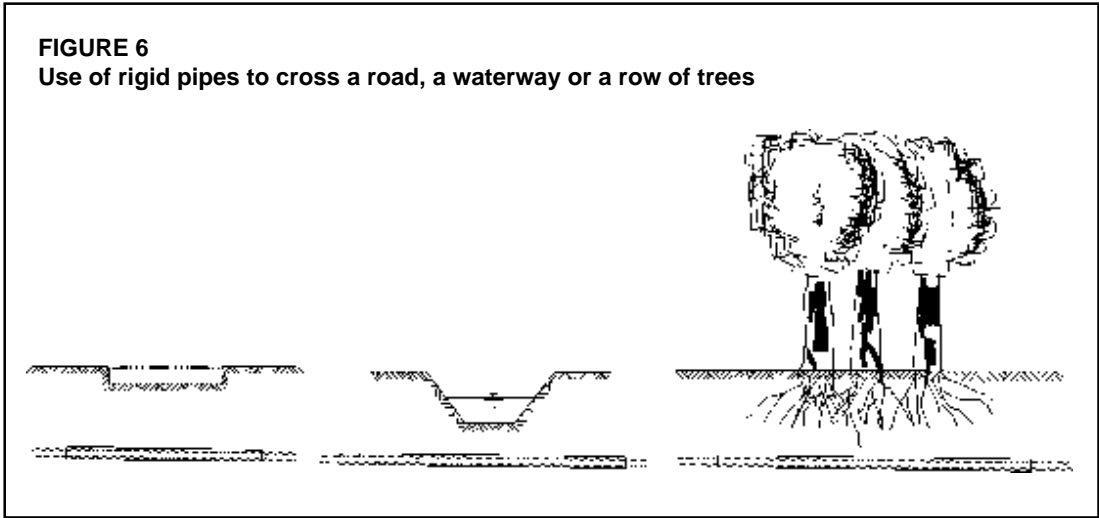

## Surface inlets

Surface water inlets are incidentally used to evacuate surface water from localized areas through the drainage system when the construction of ditches is not feasible or impractical. A proper silt trap is essential to prevent or reduce drain siltation. The open inlet can be in the collector line although it is better located next to the collector and connected to it with a siphon (Figure 8) as a safeguard against poor maintenance. Surface inlets are usually made of masonry or cast-in-place concrete, but concrete and rigid plastic pipes can also be used. A metal grating is usually installed to restrict the entry of trash and waste.

## CONNECTION STRUCTURES

### Junction boxes

Junction boxes are used where two or more drains (laterals and/or collectors) come together or where the diameter or the slope of the collector changes. They can be pre-casted (Figure 9a) or made of masonry or cast-in-place concrete, but also rigid plastic or concrete pipes can be used for this purpose. Junction boxes can be combined with a silt trap and extended to the soil surface (Figure 9b). The bottom of the silt trap should be at least 0.30 m below the bottom of the inlet of the downstream pipe. The invert of the entering laterals should be positioned at least 0.10 m above the top of the leaving collector to further sedimentation in the silt trap. Blind junction boxes will not hinder field works. The lid should therefore be situated at a minimum depth of 0.40 m below soil surface. They can be exposed if inspection and occasional cleaning is required. With the lid at the soil surface, the junction box is not so very much different from an inspection chamber, yet it hampers field works.

The position of blind boxes and covered manholes (see Section *Manholes*) should be well documented. Nevertheless, finding them is often difficult. If they do not contain steel components, a lid with steel bars should be installed on top of the structure in order to facilitate easy location with a metal detector.

### Manholes

Inspection chambers or manholes differ from junction boxes with a silt trap in that they provide for ready access if drains require inspection and cleaning. The material can be concrete or masonry, but also redwood has been used successfully (Luthin, 1978). Deep inspection chambers are constructed with a number of reinforced concrete rings. They should be sufficiently large and must be provided with metal rungs fixed in the wall to allow a man to descend to the drain lines (Figure 10a). Since the lid of manholes is usually above the soil surface, they are objectionable because of their interference with farming operations. To meet this objection a capped manhole, with the top at least 0.40 m under the soil surface, can be installed with the inconvenience that the top of the manhole has to be dug out for each inspection (Figure 10b).

## OUTLETS

### Gravity outlets

The outlet of laterals and collectors must be protected in case of gravity discharge of the water into an open drain system. The outlet should be reliable since malfunctioning affects the performance of the entire drain or drainage system. The outlet of laterals and smaller collector

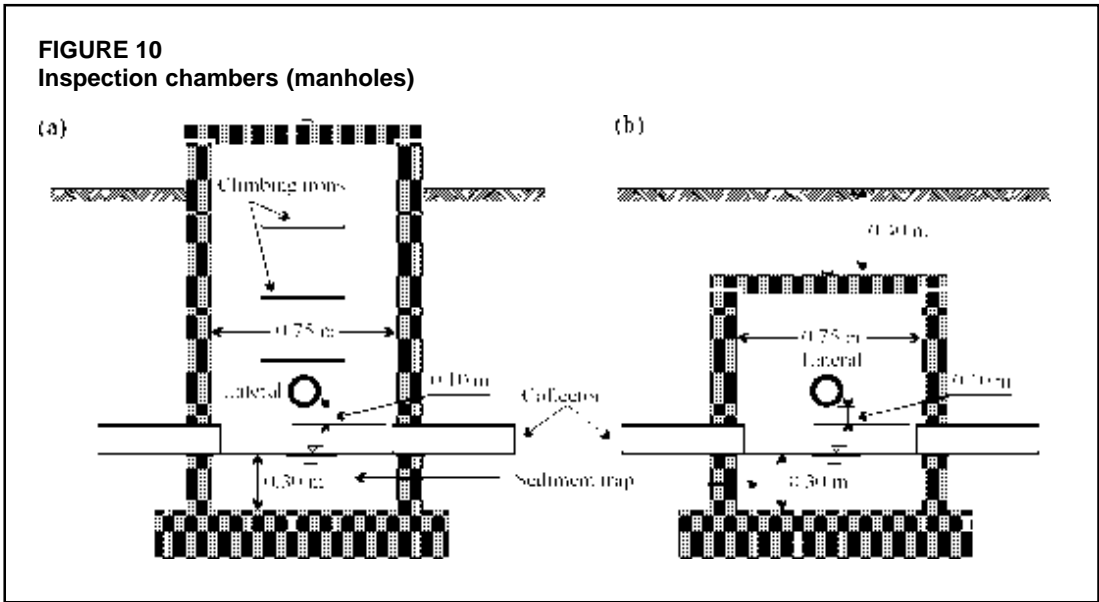
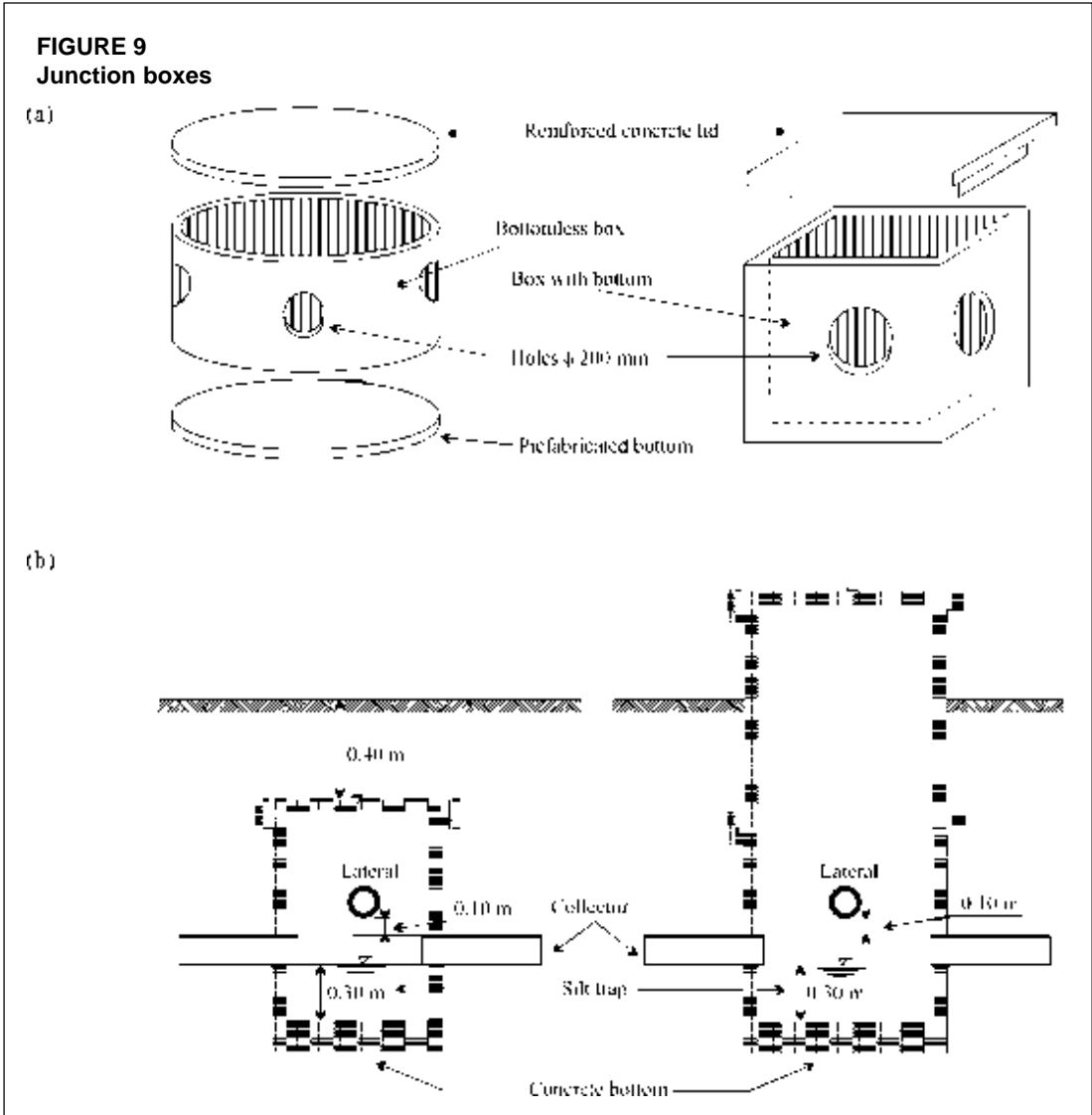

drains can be protected with a non-perforated rigid pipe made of plastic, coated galvanized steel, reinforced concrete or other materials. The length of this pipe ranges from 1.5 to 5.0 m, depending on the diameter of the drain pipe, the risk of root penetration from bank vegetation and the danger of erosion under the pipe or at the discharge point. No envelope material (particularly gravel) shall be applied near the outlet and the last few metres of the trench backfill should be well compacted over the entire depth of the trench. The outlet pipe can be connected to, or slid over the drain pipe and at least half of its length should be buried (Figure 11a).

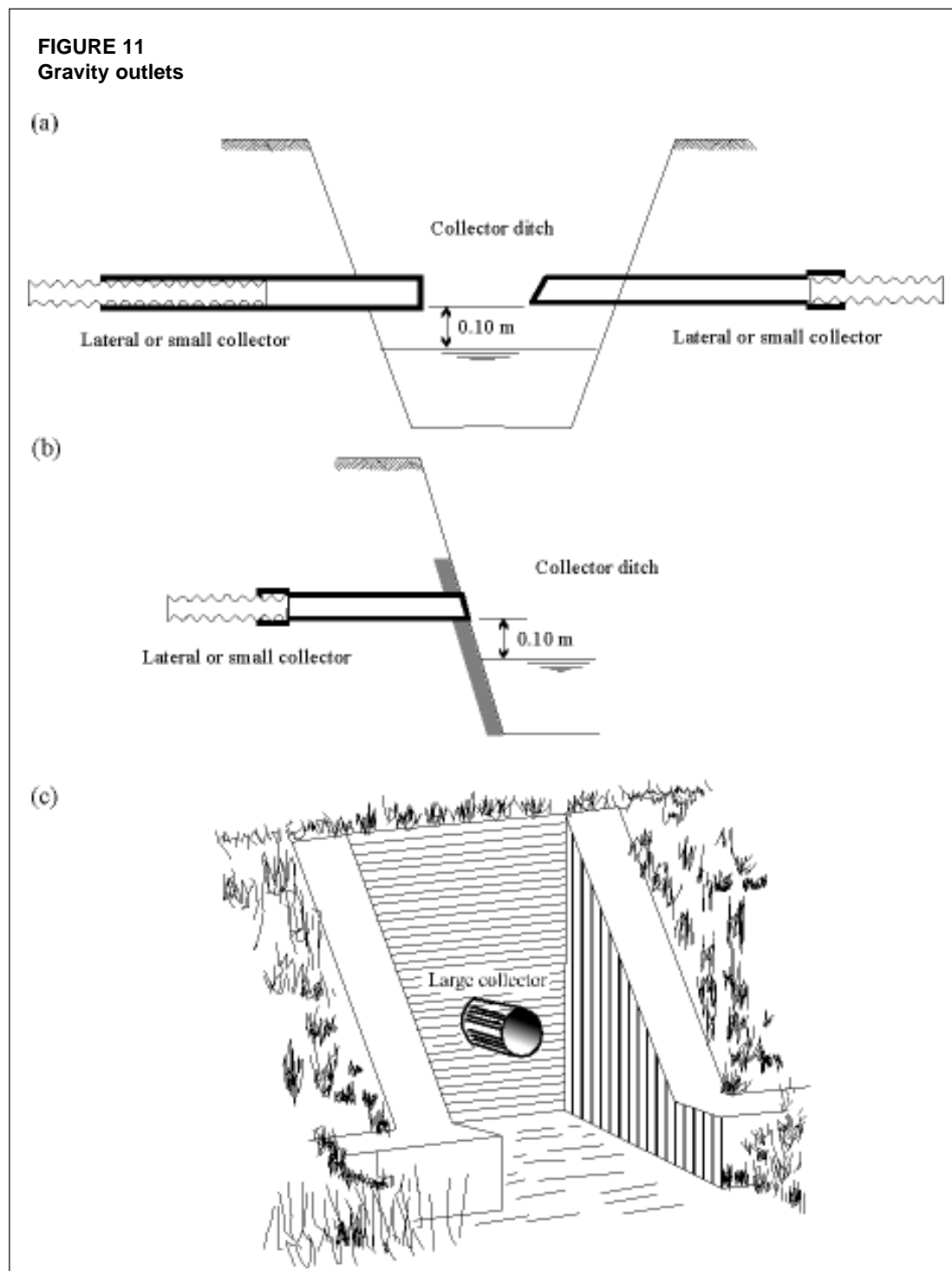

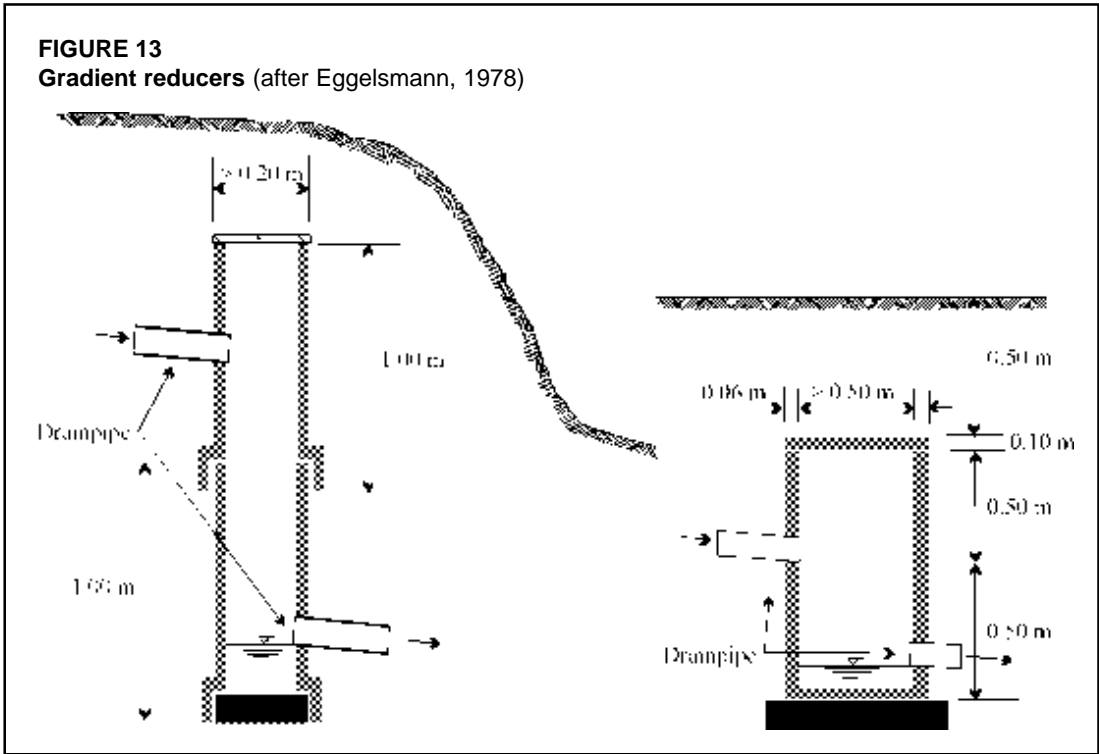
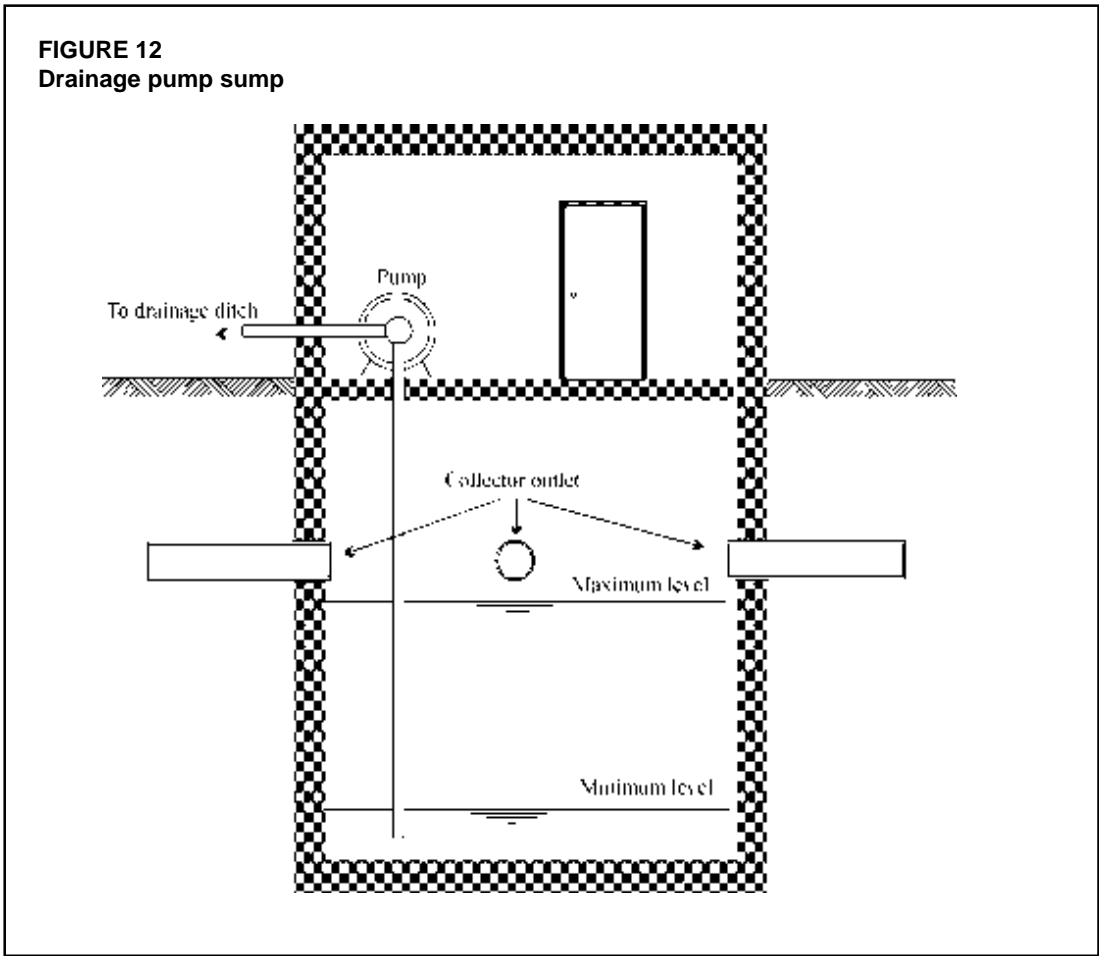



The main function of drain outlets is to prevent erosion of the ditch bank. For this purpose the unperforated end-pipe must reach far enough out to discharge above the water-level in the ditch. Support by a pole or rod may be needed to avoid sagging.

Sometimes short non-protruding outlets are used in combination with chutes protecting the side-slope of the ditch. These chutes can be halved plastic pipes or cement gutters guiding the stream (Figure 11b). A non-protruding pipe can also be used where there is danger of ice jams.

In spite of many efforts, no adequate solution is yet found to solve the problem of outlet interference with ditch maintenance. Plastic end pipes resist corrosion from chemicals in soil and water but burning off side slopes of ditches as a maintenance measure will be fatal.

Larger collector drains justify the use of a small concrete structure, made of masonry, cast-in-place concrete, or pre-cast segments (Figure 11c). Outlets should be provided with a removable screen to prevent the entry of small animals. Although the outlet into open ditches may be submerged for short periods during storms, they are usually not and should be at least 0.10 to 0.15 m above the water level in the ditch at normal flow (Figure 11).

### **Pumped outlets**

Pumps are used for the discharge of water from a drainage system into an outlet ditch, when gravity outflow is not possible because of insufficient outlet depth. This situation is common with deep drainage systems that are designed for salinity control in arid and semi-arid regions. In other areas they may be needed because of insufficient outlet levels. Collector lines discharge into a storage sump with concrete base, where a float-controlled pump periodically empties the sump (Figure 12). Pumped outlets are more expensive than gravity outlets, not only because of the initial cost of equipment, but also due to costs associated with maintenance and power consumption.

Pumped outlets are equipped with a power unit (either electric motor or diesel engine), and pumps and pipes for lifting collected drainage water to a shallow gravity outlet. Small sumps can be constructed with large diameter plastic, asphalt-coated corrugated steel or concrete pipes while larger sumps shall be made of reinforced concrete rings, masonry or reinforced concrete.

## **SPECIAL STRUCTURES**

### **Gradient reducers**

A gradient reducer may be required in sloping lands to reduce excessive flow velocities in drain pipes and prevent erosion and subsequent water movement through channels formed outside the pipe. They can be made of concrete or plastic pipes, or of masonry or concrete (Figure 13). They are in fact blind junction boxes of great height with the entering pipe near the top and the leaving pipe near the bottom of the box.

### **Cleaning facilities**

Although cleaning of properly designed and carefully installed drainpipes should be exception rather than general rule, there may be circumstances where drains require regular cleaning (e.g. if iron ochre is formed). Cleaning of laterals of a composite drainage system, equipped with blind junctions is possible only after dismantling of some of these connections. The provision

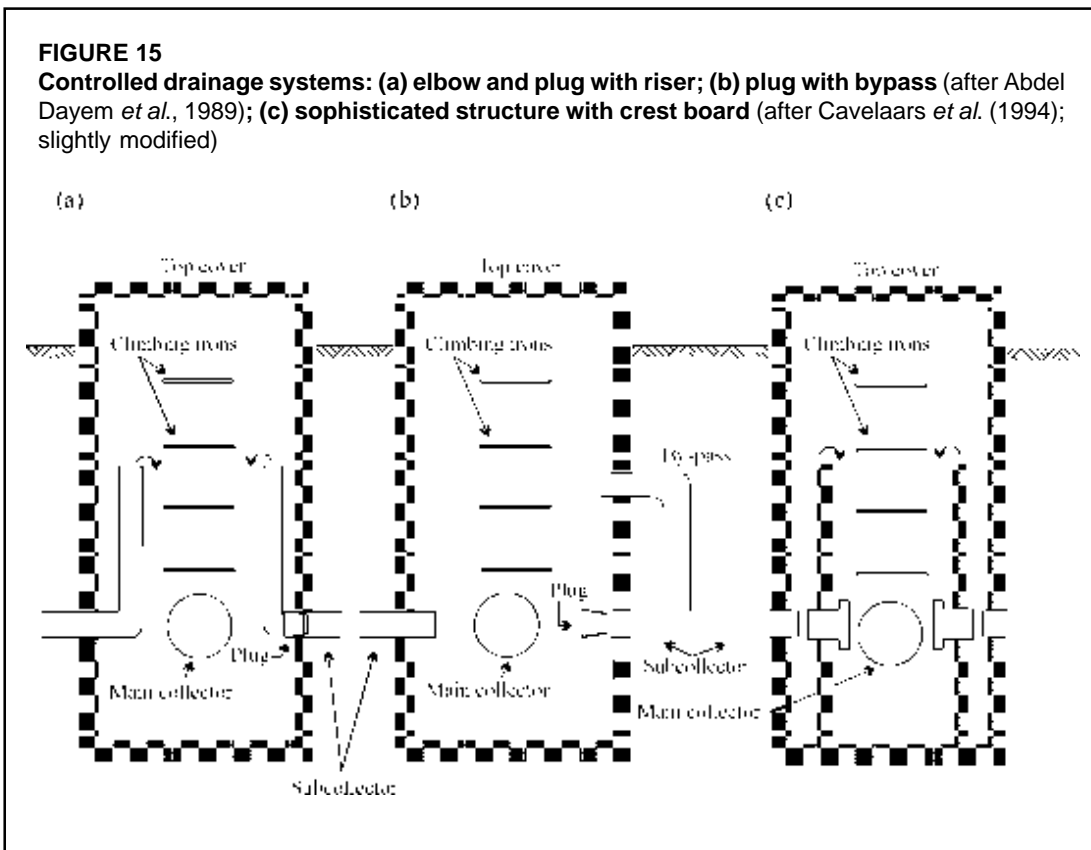
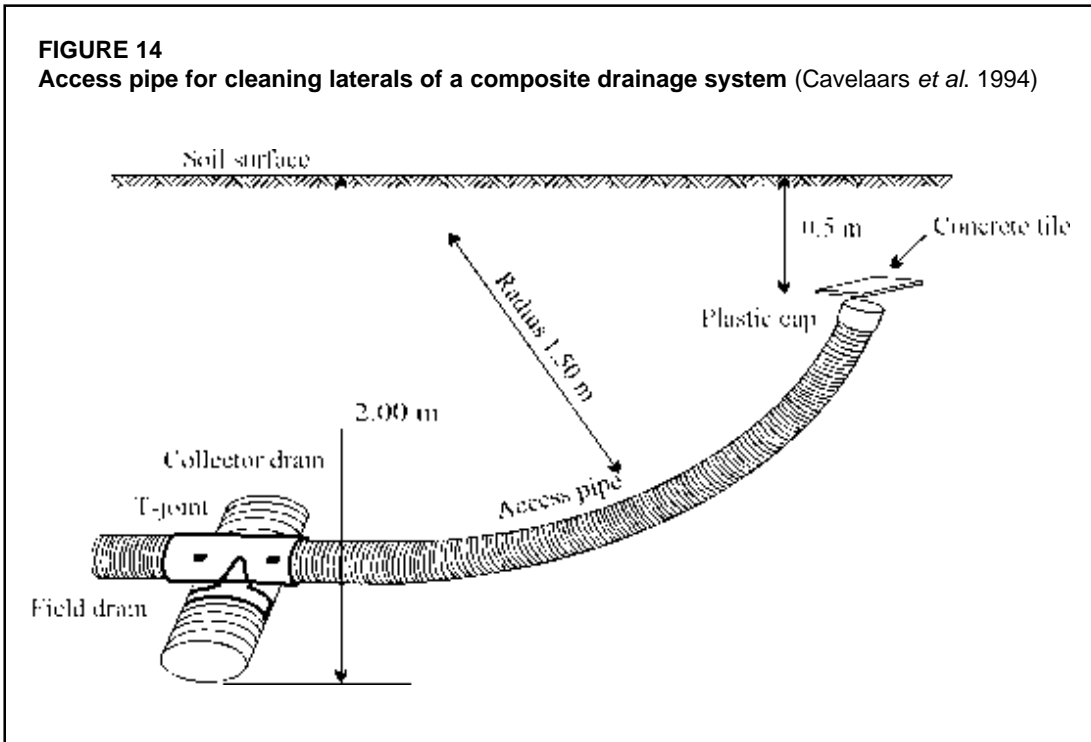

of special fittings (Figure 14) however facilitates cleaning by flushing without having to excavate and dismantle junctions. A concrete tile with steel bars above the access pipe allows easy retrieval with a metal detector from the soil surface (Cavelaars *et al.*, 1994).

### **Structures for controlled drainage and subirrigation**

There can be some reasons to reduce drainage temporarily (e.g. environmental considerations, unwarranted and harmful leaching of fertilizers in winter, supplementary irrigation and special water regimes for rice and other crops). Devices for controlled drainage can be installed in open ditches or on subsurface drains. Unperforated pipes with a length of 5 m, leading drains into or from the control structure, should be used to prevent seepage around the structure. Very simple control tools can be used such as an elbow or plug with a riser (Figure 15a) or a plug with a bypass (Figure 15b). Structures with crest boards are common in open ditches. Very sophisticated structures with crest boards (Figure 15c), floats or electric water level sensors in a sump, either located on the drain line or midway between drains, can be used as well (Madramootoo *et al.*, FAO, 1997; Schwab and Fouss, 1999). Simple yet reliable control devices can be made locally, however, with available means. Control structures are made of masonry, cast-in-place concrete or pre-cast segments.

Drainpipes serving both drainage and irrigation purposes are sometimes laid without slope. However, this is not necessary as long as the gradient remains sufficiently small. Automatic controls are required to maintain the water level at the drainage outlets, which serve as inlets for subirrigation systems. Subirrigation should not be practised in arid regions where soil salinity is a potential problem.



## Chapter 3

# Envelope materials

Porous material placed around a subsurface drain, to protect the drain from sedimentation and improve its hydraulic performance, should be referred to as a drain envelope. It is worthwhile to distinguish between the definition and function of an envelope and that of a filter.

During the early development of design criteria for drain envelopes, existing filter criteria were often used as a basis for research. Hence, the word 'filter' is often mistakenly used in reference to drain envelopes. A filter is by definition 'a porous substance through which a gas or liquid is passed to separate out matter in suspension' (Merriam-Webster, 1993). Filtration also is defined as 'the restraining of soil or other particles subjected to hydraulic forces while allowing the passage of fluids' (ISO 10318, 1990). Hence, a *filter*, used as a drain envelope, would eventually become clogged because particulate matter would be deposited on or in it, reducing its permeability.

*Envelopes* have the task to improve the permeability around the pipe, and act as permeable constraints to impede entry of damaging quantities of soil particles and soil aggregates into drainpipes. Yet the majority of small particles of soil material and organic matter, suspended in water moving toward a drain, will actually pass through a properly selected and installed drain envelope without causing clogging. The relatively coarse envelope material placed around the drain should stabilize the soil mechanically and hydraulically, but should not act as a filter.

In addition to the functions described above, drain envelopes can improve the bedding conditions. This bedding function is primarily associated with gravel envelopes in unstable soils. Gravel provides a mechanical improvement in the drain-envelope-soil system, serving as bedding and side support for large diameter plastic pipes (Framji *et al.*, 1987).

Envelope materials used to protect subsurface drains have included almost all permeable porous materials that are economically available in large quantities. Based on the composition of the substances used, they can be divided into three general categories: mineral, organic, and synthetic envelopes.

### **MATERIALS**

#### **Granular mineral envelopes**

Mineral envelopes mainly consist of coarse sand, fine gravel and crushed stone, which are placed under and around the drainpipe during installation. If well designed and installed, mineral granular envelopes are quite reliable because they are voluminous and can store comparatively large quantities of soil material without noticeable malfunctioning. As such, they have provided satisfactory long-term service under most circumstances. Traditionally, pit run naturally graded coarse sand or fine gravel containing a minimum of fines is the most common and widely used

drain envelope material. Such material can be as permanent as the soil itself. Properly designed graded gravel envelopes fulfil all the mechanical and hydraulic functions of a drain envelope and are the ideal envelope from a physical standpoint.

Graded gravel should be a homogeneous, well-graded mixture of clean sand and gravel free from silt, clay, and organic matter, which could adversely affect its permeability. The use of limestone particles must be avoided, because a high percentage of lime in gravel envelopes is a source of incrustation. In addition, the gradation of a gravel envelope should be made in accordance to prescribed parameters (Section *Specifications for gravel envelopes*).

The use of gravel as drain envelope has become a bit controversial. One of the conclusions of a symposium held in Wageningen, The Netherlands in 1986 was the following: 'Gravel remains for the time being the most reliable filter material. In view of the cost of gravel the development of design criteria for synthetic materials merits the highest priority' (Vos, 1987). However, at a conference, held in Lahore, Pakistan in 1990 which was devoted specifically to the design and application of envelopes, it was concluded that engineers who were not familiar with synthetic envelopes, were reluctant to recommend their use (Vlotman, 1990). Considering the current tendency, it may be assumed that synthetic envelopes will gradually replace the application of gravel as envelope material in future drainage projects.

### **Organic envelopes**

Organic materials, many of which are by-products of agricultural production, have successfully been applied as drain envelopes. They are voluminous, so they can be used in cases where both particle retention and hydraulic function are important. Organic materials may be applied directly on the drainpipe in the trench as loose blinding material, or may be prewrapped around the drainpipe as Prewrapped Loose Materials (PLMs). An intermediate type of application has been in strip-form, applied on top of the drainpipe. This type of application is now obsolete.

Organic envelope materials include chaff, cereal straw, flax straw, rice straw, cedar leaf, bamboo, corncobs, wood chips, reeds, heather bushes, chopped flax, flax stems, grass sod, peat litter and coconut fibre (Juusela, 1958; Framji *et al.*, 1987).

In northwestern Europe (Belgium, Germany, and The Netherlands), the most common organic envelopes were made from peat litter, flax straw and coconut fibres. The use of fibrous peat litter as a cover layer of drain tiles has been common practice for decades until the end of the 1950s. It was found that the hydraulic conductivity of the peat litter would often decrease drastically due to swelling of the envelope under permanently wet conditions due to e.g. subirrigation (Rozendaal and Scholten, 1980).

During the subsequent period, flax straw has been used. It was applied originally as a cover strip and later as prewrapped envelope. The coarseness of the flax envelope did however not always guarantee the particle retention function. On a much smaller scale, other organic envelopes have been applied. These materials were not always available in the required quantities and their handling was often laborious. The use of straw was not successful because it usually decomposed into a low-permeability layer around the pipe.

At the end of the 1960s, coconut fibre (Figure 16) was introduced (Jarman and Jayasundera, 1975). Being relatively cheap, it soon dominated the market because high quality peat litter became scarce and expensive (Meijer, 1973) and because the flax industry declined. Moreover, the finer coconut fibre was considered a more appropriate envelope material than the coarser-

structured flax straw. Very soon it was discovered that coconut fibres were often subject to microbiological decay (Meijer and Knops, 1977; Antheunisse, 1979, 1980, 1981). The envelopes were usually fully decomposed after two to five years, particularly if the pH of the soil exceeded the value 6. More than a decade later, many farmers complained about mineral clogging of their drains. A research project was set up to investigate the problem of mineral clogging. More than 1000 excavations were made and they confirmed that the mineral clogging problems, although

partly due to the large effective pore size of the coconut fibre envelope, mainly resulted from the decomposition of the organic substances (Blom, 1987).

In the mid-1980s, various attempts were made to retard or stop the decomposition of organic envelope materials. In Germany and in France a so-called 'Super-Cocos' envelope was introduced. Its fibres were impregnated with copper sulphate ( $\text{CuSO}_4$ ), to kill the bacteria that cause the decomposition (Antheunisse, 1983, 1984). In addition, some envelopes contained tiny copper wires. 'Super-Cocos' envelopes had limited success because decomposition was postponed for a few years only. In addition, environmental legislation made installation of 'Super-Cocos' illegal in most countries, because the chemical agent leached out rapidly. Coconut fibre envelopes are still being applied in northwest Europe due to their comparatively low price, but their use is declining in favour of synthetic materials.

Organic envelopes have never been popular in countries located in arid climates because the comparatively high soil temperature activates microbiological activity and consequently accelerates their decay. In the irrigated lands of the arid tropics, organic envelope materials usually fail (Van der Molen and Van Someren, 1987). The successful application of organic envelopes in the Scandinavian countries, where mainly fibrous peat and wood chips were used, was due to the reduced microbiological activity at lower soil temperatures.

The service life and suitability of organic materials as envelopes for subsurface drains cannot be predicted with certainty. Eventually, the majority of organic envelopes will decompose, without any serious impact on the structural stability of the surrounding soil. Hence, these materials should be applied only in soils that become mechanically stable within a few years after installation of the drainage system (Van Zeijts, 1992). In addition, organic envelopes may affect chemical reactions in the abutting soil. This process may result in biochemical clogging of the drain. If iron ochre clogging of drains is likely, reluctance with the application of organic envelopes is justified. Even organic matter that is accidentally mixed with trench backfill material may severely enhance the risk of ochre clogging of the drain (Chapter 5).

The rapid decay of coconut fibre envelopes has stimulated the search for affordable, synthetic alternatives. The fact that synthetic envelopes can be more easily manufactured according to specific design criteria than organic ones has played a significant role in this development.

**FIGURE 16**  
**Coconut fibre PLM envelope**



## Synthetic envelopes

### *Prewrapped loose materials*

A synthetic PLM is a permeable structure consisting of loose, randomly oriented yarns, fibres, filaments, grains, granules or beads, surrounding a corrugated drainpipe, and retained in place by appropriate netting and/or twines. Synthetic PLM envelopes are usually wrapped around the corrugated plastic drainpipes by specialized companies and occasionally in pipe manufacturing plants. The finished product must be sufficiently strong to resist handling and installation without damage.

Synthetic PLMs include various polymeric materials. Fibres may be made of polyamide (PA), polyester (PETP<sup>1</sup>), polyethylene (PE), and polypropylene (PP). Loose polystyrene (PS) beads can be wrapped around drains as PLMs in perforated foil or in string netting ('geogrids' or 'geonets'). The beads are subject to compression from soil loads that may reduce envelope permeability (Willardson *et al.*, 1980). In various European countries where the drain depth ranges from 0.9 to 1.2 m, the effect of the soil load is however relatively small. PLM envelopes made from PP (waste) fibres are increasingly used in northwest Europe and in arid areas where they replace expensive gravel.

Information on some envelope materials, which are shown in Figures 17-20, is given below. Figures concerning the market shares of various envelope materials ('turnover') are given for The Netherlands, in 1997, for illustrative purpose only. The data are based upon the *installed lengths* of wrapped drainpipes.

PLM envelopes made from polypropylene waste fibres (PP-300) (Figure 17) are installed almost exclusively in Belgium for private drainage projects (turnover: 6 percent).

*PP-450 envelope* (Figure 18) is a PLM envelope, manufactured from bulk continuous filaments. These filaments are waste when producing woven PP fibre carpets. In The Netherlands, it is by far the most popular envelope material (turnover: 65 percent).

**FIGURE 17**  
**PLM envelope made from polypropylene waste fibres (PP-300)**



**FIGURE 18**  
**PP-450 envelope**



<sup>1</sup> 'PETP' is an acronym for polyethylene terephthalate.



*PP-700* envelope is a PLM material, made from new PP fibres (Figure 19). Wrapping of pipes with this envelope is comparatively laborious, hence the high price (turnover: 4 percent). It is mainly used for larger pipe diameters (exceeding 160 mm).

Due to the declining availability of PP waste fibres at competitive prices, waste PA fibres are used occasionally. Contrary to PP fibres, PA fibres absorb water as a result of which the coils may substantially increase in weight. In addition, it is more difficult to process PA fibres to homogeneous prewrapped envelopes because of problems with static electricity.

*PS-1000* is a PLM envelope material that is manufactured from compressible PS beads in netting (Figure 20) and almost exclusively installed in agricultural areas where flower bulbs are grown (turnover: 7 percent). In these areas, the groundwater contains a relatively high amount of suspended particles, and PS-1000 has proven a very reliable envelope. In this application, the higher price of PS-1000 is a good investment; no farmer can afford to have drainage systems fail.

Synthetic materials deteriorate when exposed to solar (UV) radiation. Experiments with PLM envelopes, made of PP fibres in a temperate climate have indicated that deterioration can be hazardous within three years (Dierickx, 1998b). The speed of the deterioration will be double in semi-arid and arid regions where the average annual radiation is twice that in temperate regions. However, once installed, synthetic PLM envelopes, manufactured from suitable raw material (e.g. recycled PP fibres) are not subject to decomposition. These materials are therefore reliable and affordable substitutes for conventional gravel and organic envelopes.

Prewrapping with loose materials is limited to diameters of 200 mm or smaller. Once prewrapped around drains, PLM envelopes have functional properties that are similar to those of geotextiles.

**FIGURE 19**  
**PP-700 envelope**



**FIGURE 20**  
**PS-1000 envelope**

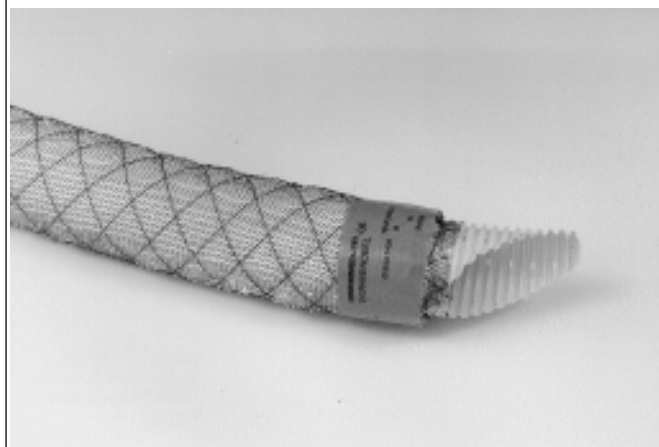

### *Geotextile envelopes*

According to prEN<sup>2</sup> 30318 (1998), a geotextile is defined as ‘a planar, permeable, polymeric (synthetic or natural) textile material, which may be woven, non-woven or knitted, used in contact with soils and/or other materials in civil engineering for geotechnical applications’. This definition includes application in agriculture since civil engineering incorporates drainage engineering in many countries.

Woven geotextiles are manufactured by interlacing, usually at right angles, two or more sets of yarns, fibres, filaments, tapes, or other elements. Non-woven geotextiles are sheets, webs, or batts, consisting of directionally or randomly oriented fibres, filaments, or other elements. These elements are bonded by mechanical, thermal and/or chemical means. Knitted geotextiles are manufactured by interlooping one or more yarns, fibres, filaments, or other elements.

The fibres, used for production of geotextiles are made from the same raw materials as those used for PLMs, namely: polyamide (PA), polyester (PETP), polyethylene (PE), and polypropylene (PP). The fibres of geotextiles may be monofilaments, multifilaments or tapes; the latter either flat, fibrillated or twisted. The combination of raw materials, fibre configuration and weaving, bonding or knitting techniques results in many types of geotextiles which differ widely in appearance, physical, mechanical and hydraulic properties.

In principle, geotextiles may be used as envelope material for drainpipes because they possess two important properties that are required for a drain envelope, namely water permeability and soil particle retention. Moreover, they facilitate the water acceptance of drainpipes, and they convey water in their plane, alongside the pipe wall. Woven geotextiles, however, are seldom used for the manufacturing of drain envelopes. The only justification for this fact must be their comparatively high price, because their specifications are indeed favourable.

In some European countries where organic and synthetic PLMs are used, there is persistent reluctance to use geotextiles as drain envelope because it is argued that their fine texture may enhance mineral and ochre clogging. Yet in countries with a geotextile industry like France, Canada and the United States, geotextile envelopes are applied successfully at a large scale. Laboratory experiments, field trials and practical experiences do not give clear evidence of the clogging risk of properly selected and properly installed fine textured geotextiles. There are, however, circumstances where fine textured geotextiles should preferably not be used (see Chapter 5).

An example of a geotextile envelope is *Typar* which is the brand name of a non-woven fabric, made of continuous filaments of 100 percent polypropylene without any extraneous binders (Figure 21).

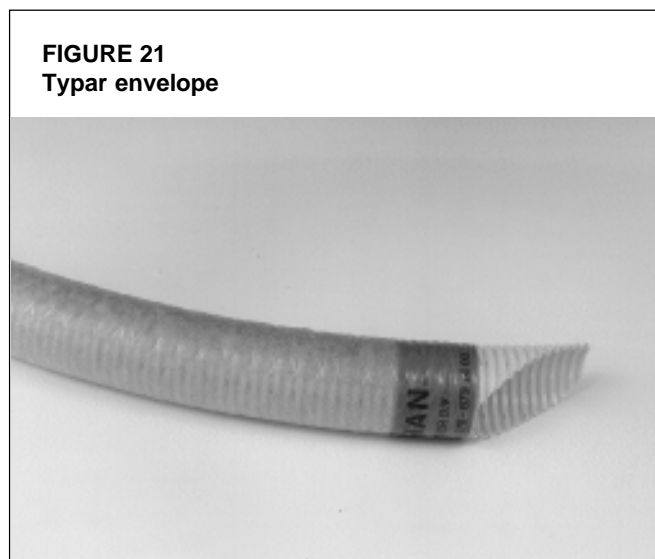

<sup>2</sup> prEN is a draft European standard (EN) that is not yet finalized.

Wrapping of drains with geotextiles can be done for any diameter. Geotextile strips can be tied around the corrugated drain, or pulled over it after the edges have been sewn together.

Geotextiles that are exposed to solar natural weathering are also vulnerable to degradation. Rankilor (1992) recommends that exposure of geotextiles to natural weathering may not last longer than two months in temperate regions and only one week in arid and semi-arid regions. Geotextiles, manufactured from organic raw material such as jute will decay in a similar fashion as organic PLMs do, while synthetic geotextiles, like synthetic PLMs, do not.

#### **SPECIFICATIONS FOR DRAIN ENVELOPES**

In 1922, Terzaghi developed 'filter' criteria to control seepage under a dam. These criteria have since been tested for applicability for envelopes around subsurface drains. Terzaghi recommended that the 'filter' material be many times more pervious than the soil base material but that it not be so coarse that the base material would move into the 'filter'. Terzaghi's development has served as a basis for much work done since that time on gravel envelope design. For drain envelopes, his design criteria have been tested and modified, but his original concepts have been generally accepted.

Van Someren (FAO, 1972) reported on the research into and the guidelines for selection and application of drainage materials (pipes and envelopes) in various countries. In Belgium and The Netherlands, efforts were made to develop special design criteria for prewrapped loose materials (PLMs). Conventional design criteria were largely determined by analogue models in laboratories, supported by theoretical considerations, and verified by field trials. Monitoring the flow of water and soil particles near prewrapped drainpipes in the field was not an easy task without disturbing the system. In addition, the data, emerging from field experimentation are inevitably blurred because it is site specific. Results achieved at some places are not necessarily replicable at other locations.

Knops *et al.* (1979) published the first set of comprehensive guidelines for the selection of the then used prewrapped envelopes for use in Dutch soils. Subsequently, a series of research projects and concurrent practical evaluations, carried out by various companies and institutions, have produced design and application criteria for drain envelopes made of PLMs in The Netherlands (Huinink, 1992; Stuyt, 1992a; Van Zeijts, 1992). Many field surveys have been made into the possible factors that affect pipe sedimentation.

Drain envelopes should meet specifications but visual evaluation of materials is also important. Even if the best materials have been used and all specifications are met, a drainage system will not operate properly if envelopes exhibit some shortcomings due to careless wrapping, handling or installation.

#### **Specifications for gravel envelopes**

Specifications for gravel envelopes are discussed extensively in numerous publications. This section contains all the major issues. Sound design criteria for traditional granular envelopes (gravel and coarse sand) are available and have been applied successfully in practice (Terzaghi and Peck, 1961; Vlotman *et al.*, in press; Stuyt and Willardson, 1999).

The US Army Corps of Engineers and the US Bureau of Reclamation have made extensive studies of gravel envelopes. The result is a set of specifications for graded gravel envelopes, which have been successfully used by the Soil Conservation Service (SCS, 1973), the US Bureau of Reclamation (USBR, 1993) as well as outside the United States.

The gradation curve of a proposed gravel envelope should be matched to the soil to be drained, as well as to the pipe perforations (Willardson, 1979). In addition, gravel should be internally stable to avoid internal envelope erosion. The general procedure for designing a gravel envelope for a given soil is as follows:

1. make a mechanical particle size analysis of both the soil and the proposed gravel envelope;
2. compare the two particle size distribution curves; and
3. decide, by some design criterion, whether the proposed gravel envelope material is suitable.

The involved design criteria consist of rules that prescribe how to derive the particle size distribution, required for a suitable gravel envelope, from particle size distribution data of the soil, in order to guarantee satisfactory service of the envelope.

### *Terzaghi's criteria*

The first criteria, proposed by Terzaghi (US Army Corps of Engineers, 1941) for what he termed a 'filter', are:

- The particle diameter of the 15 percent size of the filter material ( $D_{15}$ )<sup>3</sup> should be at least four times as large as the diameter of the 15 percent size of the soil material ( $d_{15}$ ):

$$D_{15} \geq 4 d_{15}$$

This requirement would make the filter material roughly more than ten times as permeable as the soil.

- The 15 percent size of the filter material ( $D_{15}$ ) should not be more than four times as large as the 85 percent size of the soil material ( $d_{85}$ ):

$$D_{15} \leq 4 d_{85}$$

This requirement would prevent the fine soil particles from washing through the filter material.

Bertram (1940), Karpoff (1955), and Juusela (1958) suggested similar or modified 'filter' design criteria for use with subsurface drains.

### *Criteria of the US Soil Conservation Service*

The SCS (1971) has combined the results of the research on gravel envelopes into a specification for evaluating pit run and artificially graded granular materials for use as drain envelope materials. These specifications are superseded by more recently published specifications (SCS, 1988), which distinguished between 'filter' and 'envelope'. The recommendation for naturally graded materials or a mixture of medium and coarse sand with fine and medium gravel for use as envelope is:

- $D_{100} \leq 38$  mm.
- $D_{30} \geq 250$   $\mu$ m.
- $D_5 \geq 75$   $\mu$ m.

Additional criteria are suggested to prevent excessive fineness of an envelope material, designed to be used for finer textured soils (SCS, 1988):

---

<sup>3</sup> The particle diameter  $D_x$  of the  $x$  percent size by weight of the filter material is defined as the diameter sieve where  $x$  percent passes. This also holds for the soil parameter  $d_x$ .

- $D_{15} < 7 d_{85}$  but  $D_{15} \geq 0.6$  mm.
- $D_{15} > 4 d_{15}$ .

### Criteria of the US Bureau of Reclamation

For rigid, unperforated pipes, the US Bureau of Reclamation treats the joint opening, the length of the pipe section, and the hydraulic conductivity of the envelope material as a unified system. Their Drainage Manual (USBR, 1978, 1993) contains graphs which consider all these factors. Table 1, taken from this manual, gives recommended envelope gradations for soils with different 60 percent passing sizes.

**TABLE 1**

**Gradation relationships between soil and diameters of graded granular envelope material** (after USBR, 1978, 1993)

Soil, 60% passing (diameter of particles, mm)	Gradation limitations for envelope (diameter of particles, mm)											
	Lower limits, percentage passing						Upper limits, percentage passing					
	100	60	30	10	5	0	100	60	30	10	5	0
0.02-0.05	9.52	2.0	0.81	0.33	0.3	0.074	38.1	10.0	8.7	2.5	-	0.59
0.05-0.10	9.52	3.0	1.07	0.38	0.3	0.074	38.1	12.0	10.4	3.0	-	0.59
0.10-0.25	9.52	4.0	1.30	0.40	0.3	0.074	38.1	15.0	13.1	3.8	-	0.59
0.25-1.00	9.52	5.0	1.45	0.42	0.3	0.074	38.1	20.0	17.3	5.0	-	0.59

For some fine-textured and salty problem soils in Pakistan, the USBR criteria produced gravel envelopes that were obviously too coarse, allowing excessive amounts of fine soil materials to enter the drains (Vlotman *et al.*, 1990).

### Other criteria

Since the design of gravel packs for wells is similar to the design of envelopes for subsurface drains, the criteria developed by Kruse (1962) for gravel packs may also be used for gravel envelopes. These criteria are based on the ratio of the 50 percent size of the pack (envelope) material to the 50 percent size of the aquifer (soil) and on the uniformity of the textural composition (see Chapter 6, Section *Physical properties of the soil*) of both the aquifer and the gravel. Kruse (1962) observed that sand movement was reduced by decreasing the uniformity of the gravel (i.e. increasing its uniformity coefficient) at all gravel-aquifer ratios and therefore distinguished between uniform soil and gravel pack up to a uniformity coefficient of 1.78 and non-uniform soil and gravel pack for larger values. The proposed maximum permissible gravel/aquifer particle size ratios for the various combinations of textural composition of both the aquifer and the gravel pack, to prevent excessive movement of aquifer material, are given in Table 2.

Besides the 50 percent ratio of filter to aquifer material, Pillsbury (1967) also used the standard deviation resulting from the difference between the 95 percent and 50 percent sizes of the grading curve of the gravel envelope divided by 1.645, as a

**TABLE 2**

**Largest permissible gravel/aquifer size ratios** (after Kruse, 1962)

Textural composition of aquifer	Textural composition of gravel pack	Gravel/aquifer particle size ratio ( $D_{50}/d_{50}$ )
Uniform (unstable)	Uniform (unstable)	9.5
Uniform (unstable)	Non-uniform (stable)	13.5
Non-uniform (stable)	Uniform (unstable)	13.5
Non-uniform (stable)	Non-uniform (stable)	17.5

criterion for its effectiveness. Pillsbury (1967) presented a graph of the 50 percent size ratio envelope-aquifer vs. this standard deviation which was divided in two zones. Envelopes that fall below the limit line were judged unsatisfactory. Based on observations of some drain envelopes that had failed in the Imperial Valley of California, Pillsbury recommended an envelope-aquifer ratio of less than 24. He concluded that concrete sand, satisfying the appropriate American Society for Testing and Materials (ASTM) standard with a 50 percent size less than 1 mm and a standard deviation greater than 1.0 would be a satisfactory envelope material under most conditions.

Sherard *et al.* (1984a, b) developed filter criteria for protection of hydraulic structures. While not intended for application in subsurface drainage, the principles may equally well be applied for the design of gravel envelopes. The authors established that if a filter did not fail with the initial flow of water, it was probably permanently safe. Well-graded materials were more successful than uniform materials.

Sherard *et al.* (1984b) reported on tests with fine textured soils and concluded the following with respect to filter and base soil sizes:

- Sandy silts and clays ( $d_{85}$  of 0.1 - 0.5 mm)  $D_{15}/d_{85} \leq 5$  is safe.
- Fine-grained clays ( $d_{85}$  of 0.03 - 0.1 mm)  $D_{15} < 0.5$  mm is safe.
- Fine-grained silts of low cohesion ( $d_{85}$  of 0.03 - 0.1 mm)  $D_{15} < 0.3$  mm is safe.
- Exceptionally fine soils ( $d_{85} < 0.02$  mm)  $D_{15} < 0.2$  mm or smaller is safe.

Sands and gravely sands containing fine sand fractions and having a  $D_{15}$  of 0.5 mm or less would be a suitable filter for even the finest clays. For clays with some sand content ( $d_{85} > 1.0$  mm), a filter with a  $D_{15} = 0.5$  mm would satisfy the  $D_{15}/d_{85} \leq 5$  criterion. For finer clays, the  $D_{15}/d_{85} \leq 5$  is not satisfied, but the finer soils tend to be structurally stable and are not likely to fail. Finally, Sherard *et al.* (1984b) found that well-graded gravely sand was an excellent filter for very uniform silt or fine uniform sand, and that it was not necessary that the grading curve of the envelope be roughly the same shape as the grading curve of the soil. Gravel envelopes that have a  $D_{15}$  of 0.3 mm and a  $D_{15}/d_{85} \leq 5$  with less than 5 percent of the material finer than 0.074 mm will be satisfactory as envelope materials for most problem soils.

Dieleman and Trafford (FAO, 1976) reviewed criteria for selection of gravel envelope materials and included some comments regarding envelope selection for problematic soils. Dierickx (1992b) presented a summary of gravel envelope criteria from the United States and the United Kingdom. This summary clearly indicates that the criteria from various sources do not match, even if one takes into account the difference between 'filter' (mechanical) function and 'envelope' (hydraulic) function. This fact has prompted new research projects that have yielded new findings, i.e. improvements of existing criteria, which may be used to improve the design gravel envelopes (Vlotman *et al.*, 1997). Another finding of interest was that rounded and angular particles gave equivalent results (Vlotman *et al.*, 1992b).

### Specifications for prewrapped envelopes

Prewrapped envelopes may be organic PLM, synthetic PLM and geotextile. Their physical properties such as thickness and mass per unit of surface area are important to check the uniformity of the envelopes, and their conformity with the required design standards. Characteristic opening size, hydraulic conductivity and water repellence determine the hydraulic

properties of prewrapped envelopes. When using loose granular materials, particle size distribution parameters may be used as well. Depending on what kind of drain pipes is used and how envelope materials are wrapped around drainpipes, some mechanical properties of envelopes such as compressibility, abrasion damage, tensile strength and static puncture resistance may be part of the specifications.

In The Netherlands, recommendations for the design and application of PLMs have been developed on the basis of concurrent research projects, theoretical studies, mathematical modelling, empirical studies in experimental fields, analogue modelling in laboratories and practical experience covering a 30-year period (1960-1990) (Stuyt, 1992a).

### **Thickness**

The *thickness* of prewrapped envelopes serves as a reference for uniformity and conformity. In addition, envelope thickness is found a factor of importance in theoretical analyses as it influences the soil retention capacity, the entrance resistance of drainpipes and the exit gradient at the soil-envelope interface.

The main task of an envelope is soil particle retention. In this respect, design criteria for envelope thickness are irrelevant. Thicker envelopes, however, may have higher porosities, which explain their popularity when chemical clogging is anticipated. Therefore, in the envelope selection procedure, envelope thickness is an important parameter, and often significant in terms of safety.

The thickness of an envelope should be a relevant specification if reduction of entrance resistance is envisaged or if reduction of entrance resistance is the only objective to use an envelope (see Chapter 4, Section *Entrance and approach flow resistance*). Although a thin envelope may substantially reduce the entrance resistance, the optimal reduction is obtained at a thickness of 5 mm, provided that the hydraulic conductivity of the geotextile is not the limiting factor, which will generally not be the case (Nieuwenhuis and Wesseling, 1979; Dierickx, 1980). A further increase of thickness has no marked influence on the entrance resistance, although the effective radius continues to increase since a comparatively permeable envelope replaces soil material that is usually less permeable.

When envelopes are used to reduce the exit gradient (see Chapter 4, Section *The exit gradient*), the thickness of the envelope is also a relevant design parameter. The design procedure for envelope thickness, as proposed by Vlotman *et al.* (in press) shows that even thin geotextiles ( $\leq 1$  mm) may considerably reduce the exit gradient at the soil-envelope interface. The larger the diameter of a drain, however, the smaller hydraulic gradients near the drain will be. Hence, 'thick' or 'voluminous' envelopes (i.e. thickness  $> 5$  mm) are generally considered to be safer than thin ones, particularly if the drains are occasionally used for controlled drainage or subirrigation (subsurface infiltration).

For PLM, the specification of a minimum thickness was introduced to guarantee a complete cover with a more or less homogeneous envelope. According to the provisional EN-standard (CEN/TC155/WG18, 1994), the following minimum thicknesses are required:

- Synthetic, fibrous PLMs: 3 mm (e.g. PP fibres).
- Synthetic, granular PLMs: 8 mm (e.g. polystyrene beads).
- Organic, fibrous PLMs: 4 mm (e.g. coconut fibres).
- Organic, granular PLMs: 8 mm (e.g. wood chips, sawdust).

The provisional EN-standard further specifies that the mean average thickness of each test piece should not deviate by more than 25 percent from that declared by the manufacturer.

Geotextiles are available from very thin, sheet-like fabrics to rather thick, mat-like materials.

### ***Mass per unit area***

The mass per unit area is not a selection criterion and therefore not specified. Mass determination can be carried out as a control measure for uniformity and conformity. According to the provisional EN-standard, the mass also may not deviate by more than 25 percent of the mass specified by the manufacturer in order to safeguard a homogeneous product.

### ***Characteristic opening size and retention criterion***

The characteristic opening size, derived from the pore size distribution or porometric curve of the envelope, is the most important selection criterion because it determines the effectiveness of the envelope to retain the surrounding soil material.

The retention of soil particles is normally not a problem since very fine fabrics are available. Laboratory research as well as practical experience, however, have revealed that fine envelopes are vulnerable to mineral blocking and clogging. Blocking of an envelope is a decrease of the number of active openings in an envelope that occurs when it is brought in contact with a soil. Clogging, on the other hand, is a decrease with time of the number of active openings in an envelope due to gradual accumulation of particles inside and on its surface, e.g. by particles suspended in turbid water. Therefore, specifications for envelopes should cover both soil retention criteria and criteria to prevent clogging and blocking of the envelope. Intensive research has resulted in criteria for soil particle retention and in recommendations with respect to the problems of blocking and clogging.

The capability of an envelope to retain the soil material is expressed as a ratio of some characteristic pore size of an envelope to some characteristic particle size of the soil in contact with this envelope. In many countries, the  $O_{90}$  is used as the characteristic pore size for organic and synthetic PLMs and geotextiles alike, with a great deal of success.

The  $O_{90}$  of a drain envelope is the pore size for which 90 percent of the envelope pores are smaller. The  $O_{90}$  value is usually obtained by dry sieving of well-known sand fractions, whereby the envelope itself is installed as a sieve and the retained amount of each fraction is recorded. Wet and hydrodynamic sieving, also applied for this purpose, use graded soil and mostly result in smaller  $O_{90}$  values than those obtained with dry sieving.

In 1994, a working group of scientists and engineers in Europe developed a new classification system for PLMs. They introduced three classes of envelopes, depending on the effective opening size of the envelope pores,  $O_{90}$ , as follows:

PLM-XF extra fine	$100 \mu\text{m} \leq O_{90} \leq 300 \mu\text{m}.$
PLM-F fine	$300 \mu\text{m} \leq O_{90} \leq 600 \mu\text{m}.$
PLM-S standard	$600 \mu\text{m} \leq O_{90} \leq 1100 \mu\text{m}.$

In the provisional EN-standard (CEN/TC155/WG18, 1994) only two classes, namely PLM-F and PLM-S have been accepted.

In The Netherlands, practical guidelines for envelope application consider three 'standard'  $O_{90}$  values, namely 450, 700 and 1000  $\mu\text{m}$ , 450  $\mu\text{m}$  being by far the most widely applied, and



servicing a great variety of soils. These figures were accepted after Stuyt (1992a), using field data, confirmed evidence of the soundness of the  $O_{90}$  parameter. In Belgium, the  $O_{90}$  of a PLM envelope should range between 600 and 1000  $\mu\text{m}$  for official drainage works.

A frequently used **retention criterion**, also called filter criterion or bridging factor of an envelope, is the ratio  $O_{90}/d_{90}$ . In this ratio,  $d_{90}$  is the particle diameter of the soil in contact with the envelope where 90 percent of the particles, by weight, is smaller. Numerous other retention criteria have been proposed in the scientific literature, which have been published in comprehensive tables, by e.g. Dierickx (1993) and Vlotman *et al.* (in press). For the design engineer, however, the number of criteria is confusing, the more so because many criteria are contradictory. This fact is self-explanatory, because the criteria were developed under widely different boundary conditions, using many different techniques, equipment and so forth.

Laboratory experiments have unambiguously indicated that the likelihood of soil particle retention is greater when a fabric is thicker. Hence, the characteristic pore size of an envelope may be larger for thicker envelopes, for equal retention. Indeed, retention criteria are linked to envelope thickness.

From laboratory studies with analogue soil models, Dierickx (1987), and Dierickx and Van der Sluys (1990) derived the following simple retention criteria for subsurface drainage applications:

- $O_{90}/d_{90} \leq 5$  for 'thick' envelopes  $\geq 5$  mm (PLMs).
- $O_{90}/d_{90} \leq 2.5$  for 'thin' envelopes  $\leq 1$  mm (geotextiles).

For envelopes with a thickness ranging between 1 and 5 mm, the  $O_{90}/d_{90}$  ratio may be interpolated step-wise (Dierickx, 1992a) or linearly (Vlotman *et al.*, in press). The step-wise approach gives one value of  $O_{90}/d_{90}$  for a range of thicknesses and is somewhat more practical than a linear approach which yields a specific value of  $O_{90}/d_{90}$  for each thickness.

Retention criteria for thicknesses of PLMs and geotextiles between 1 and 5 mm, according to the step-wise approach are:

- $O_{90}/d_{90} \leq 3$  for thicknesses between 1 and 3 mm.
- $O_{90}/d_{90} \leq 4$  for thicknesses between 3 and 5 mm.

Taking into account the retention criterion of a thin envelope, most problems in subsurface drainage will be prevented by envelopes for which  $O_{90} \geq 200$   $\mu\text{m}$ .

Field observations of Stuyt (1992a,b) confirmed, in a large extent, the laboratory findings. Stuyt investigated the relation between the  $O_{90}$  size of envelope materials and the thickness of the sediment layer inside the pipes using a miniature video camera five years after their installation. In total, 9634 m of drains were investigated (184 laterals). The pipes had outer diameters of 60 and 65 mm. In The Netherlands, sediment layers exceeding 15 mm are generally not tolerated. The  $d_{90}$  size of the soils was approximately 150  $\mu\text{m}$  in most cases. The correlation between the thickness of the sediment layer inside the pipes and the  $O_{90}$  size of envelope was significant (Table 3). Regardless of the  $O_{90}$  size, voluminous envelopes retained more soil than thin envelopes. Envelopes with larger  $O_{90}$  values, i.e. having larger openings, had poorer soil retention properties. The raw material from which the envelopes were manufactured was not significant. Stuyt (1992a) also found that the above-proposed  $O_{90}/d_{90}$  ratios were valid for the investigated problem soils. Most of the applied envelopes in the experimental fields had rather high  $O_{90}/d_{90}$  ratios (4 to 5).

TABLE 3

Fitted values for pipe sedimentation depth (mm) from a regression model, depending on effective opening size of the envelope pores,  $O_{90}$ , and envelope category (thin or voluminous) for observations made at three experimental fields in The Netherlands (after Stuyt, 1992a)

$O_{90}$ ( $\mu\text{m}$ )	Experimental field					
	Uithuizermeeden		Valtermond		Willemstad	
	Thin	Voluminous	Thin	Voluminous	Thin	Voluminous
250	2.1	0.9	4.5	0.8	9.7	8.5
500	3.9	2.6	6.3	2.5	11.	10.2
1000	5.6	4.3	8.0	4.3	13.2	11.9

Experiments with turbid water or water charged with soil suspensions indicate that geotextiles are vulnerable to clogging when  $O_{90}/d_{90} \leq 1$  (Dierickx, 1990; Faure, 1991). Hence, the ratio  $O_{90}/d_{90} = 1$  is the lower limit for soil particle retention, regardless of envelope thickness. The phenomena of blocking and clogging of an envelope are however not so evident, neither in laboratory experiments with soils, nor in field experiments. Therefore, the lower limit  $O_{90}/d_{90} \geq 1$  should be considered a recommendation rather than a rigid design criterion.

In the investigation made by Stuyt (1992a), envelopes with  $O_{90}/d_{90}$  near 1 had such low sedimentation depths that the envelopes appeared to act as filters. Hence, for thin geotextiles, the  $O_{90}/d_{90}$  ratio should preferably be near the upper limit. On the other hand, the upper limit, set to 5 for voluminous envelopes (Dierickx, 1987) appears safe for voluminous PLMs since a maximum sedimentation depth of 15 mm is tolerated in 60 and 65 mm outer diameter pipes (Table 3). In soils with some cohesion and, hence, some structural stability, voluminous envelopes with  $O_{90}/d_{90}$  ratios as high as 7 have been applied successfully.

In The Netherlands and in Belgium, the successfully applied retention criterion  $O_{90}/d_{90}$  for envelopes was therefore adopted as the major design parameter. Recommendations for envelope applications are also based on some additional considerations (Huinink, 1992; Van Zeijts, 1992) but the  $O_{90}/d_{90}$  criterion is the most important one.

In summary, the following retention criteria for both geotextiles and PLMs can be accepted:

- $1 \leq O_{90}/d_{90} \leq 2.5$  for envelope thickness  $\leq 1$  mm.
- $1 \leq O_{90}/d_{90} \leq 3.0$  for envelope thickness between 1 and 3 mm.
- $1 \leq O_{90}/d_{90} \leq 4.0$  for envelope thickness between 3 and 5 mm.
- $1 \leq O_{90}/d_{90} \leq 5.0$  for envelope thickness  $\geq 5$  mm.
- $O_{90} \geq 200 \mu\text{m}$ .

In order to minimize the risk of mineral clogging it is recommended that  $O_{90}/d_{90} \geq 1$ ; furthermore, envelopes that have  $O_{90}/d_{90}$  ratios near the upper limit of the proposed range of values are generally preferred.

Locally made fabrics such as carpet backing, which satisfies or may satisfy the above requirements after some modifications, are equally suitable as imported geotextiles. They may therefore be trusted as envelope materials.

### Hydraulic conductivity

The hydraulic conductivity of envelopes should be greater than that of the soil in order to reduce the entrance resistance of drainpipes, so that no hydraulic pressure will develop outside

the envelope. From research work of Nieuwenhuis and Wesseling (1979) and Dierickx (1980) it may be concluded that a substantial reduction in entrance resistance is obtained when  $K_e/K_s \geq 10$ , where  $K_e$  is the hydraulic conductivity of the envelope and  $K_s$  that of the soil (see Chapter 4, Section *Drain with envelope*).

The hydraulic conductivity, perpendicularly to or in the plane of envelope, can hardly be a problem because envelopes are much more permeable than the adjacent soil that they have to retain. Even under load, the hydraulic conductivity of compressible envelopes will meet the conductivity requirements.

If, however, envelopes are brought in contact with soil, soil particles may fill pores and partly block their openings as a result of which the hydraulic conductivity at the soil-envelope interface will decrease. In addition, envelopes may clog as a result of particle deposits and/or chemical precipitates, and become less permeable with time. Evaluation of blocking and clogging of envelopes is very difficult. If the lower limit of the retention criteria is taken into account, it may nevertheless be assumed that a favourable hydraulic conductivity ratio is guaranteed.

### ***Water repellence***

PLMs do not exhibit wetting problems, yet geotextiles may do and water repellence may be a problem. Water repellence means that a minimum water head is required on top of the geotextile, before water starts to flow through it (Lennoz-Gratin, 1992). Once the water has entered the pipe through the envelope, the repellence problem is solved and will generally not return. Wettability resistance also decreases when the geotextile is brought into contact with a moist soil. Research work carried out by Dierickx (1996a) showed that the wetting problem is mainly an initial problem of dry geotextiles. The initially required head for the majority of the tested geotextiles is smaller than 2 mm. For others, it ranges from 5 to 30 mm; one geotextile required an initial head of 64 mm. Although initial water repellence of envelopes does not seem to be widespread, geotextiles that exhibit this phenomenon should not be used as drain envelope to avoid the risk of soil structure deterioration near the envelope due to the initial stagnation of water.

In accordance with the standard on the determination of resistance to water penetration of textile fabrics ISO 811 (1981), a testing procedure has been adopted in the countries of the European Union, to examine geotextiles on water repellence in a qualitative manner (prEN 13562, 1999).

### ***Mechanical properties***

Mechanical properties of envelopes are mostly of secondary importance. Geotextiles used as drain envelope do not present specific problems since they are designed for, and are normally used in more challenging circumstances. Moreover, problems that develop occasionally because of handling (e.g. tearing) can be repaired before installation.

The *compressibility* of compressible envelopes has a major effect on the characteristic opening size and the hydraulic conductivity. The opening size normally decreases in compressed state so that a safety factor is built in automatically. The hydraulic conductivity decreases also, yet the highly permeable nature of the envelope ensures that the hydraulic conductivity ratio is met in compressed state. Moreover, the compressibility of coarser envelopes, composed of coarser fibres, is small. Easily compressible thick envelopes, made of fine fibres should not be used as drain envelope.

*Abrasion* is the wearing of a part of the envelope by rubbing against another material, either during transportation or installation of wrapped drainpipes. Open spots due to abrasion or whatever other cause, noticed before installation, should be repaired in the field, if they are not out of proportion. Abrasion during installation is less likely to occur because of the short time that the wrapped pipe is routed through the machine.

Geotextiles are wrapped around drainpipes either manually or mechanically; therefore, a certain *tensile strength* is required. Dierickx (1994) proposed a tensile strength of 6 kN/m, determined according to the wide-width tensile test (EN ISO 10319, 1996). Geotextiles must bridge the corrugations of large drainpipes and may not sag between the corrugations under the soil load. Hence, elongation should be limited, but this requirement is only meaningful if the geotextile is tightly wrapped. Since this has never been a practical problem, elongation requirements have never been put forward.

*Resistance to static puncture* also is only applicable for drains with large corrugations where a tightly wrapped geotextile bridges the corrugations. The geotextile should withstand the soil load between the corrugations, and puncturing by stones and hard soil clods. These phenomena are simulated by a static puncture test. Through this test, the force required to push a flat plunger through a geotextile can be determined. Since such a problem has never occurred in subsurface drainage so far, no requirements exist.

#### AVAILABILITY AND COST

Cost and availability of drainage materials are strongly interrelated. Costs vary continuously since these are dependent on various, partly unpredictable factors like currency exchange rates and the cost of manual labour. For reference, various indications of the cost of drainage materials are given in this Chapter.

The cost of gravel envelopes is not specified here because the local availability of suitable granular material is rapidly declining. In addition, the cost of installation is strongly dependent on local circumstances. In the Integrated Soil and Water Improvement Project (ISAWIP) in Egypt, local gravel envelopes were four times as expensive as imported Canadian synthetic fabric envelopes (Metzger *et al.*, 1992). In the Fourth Drainage Project of the International Waterlogging and Salinity Research Institute (IWASRI) of Pakistan, the cost of synthetic envelopes was found to be 40 percent lower than that of gravel envelopes. Installation of synthetic envelopes was easier and faster, too (IWASRI, 1997). Thus, even if the price of gravel is competitive, it goes hand in hand with high costs of fuel and manual labour. It is therefore irrelevant to consider the price of the raw material only. Vlotman *et al.* (in press) quote costs of gravel envelopes (material and transport) in various projects in Pakistan. For all projects, the costs of material and shipping of synthetic materials was below the cost of gravel. Unfortunately, the high cost of gravel installation compared to that of installing prewrapped pipes is not included in this analysis. The cost/benefit ratio is certainly in favour of PLM envelopes and geotextiles.

PLM envelopes, manufactured from PP fibres and coconut fibres dominate the market in northwestern Europe. PLM envelopes, manufactured from peat fibres are now used only occasionally.

An indication of the cost of drainage materials, i.e. pipes and PLM envelopes, in The Netherlands is given in Table 4. Absolute prices are not given. Instead, the relative cost of pipe and envelope material is specified for various pipe diameters and envelope materials. The figures

are based upon corrugated PVC pipe, and are quoted for contractors with high rates of turnover. The price of installation of one metre of wrapped drainpipe more or less equals that of one metre of unwrapped 60 mm pipe.

From Table 4, it can be seen that the price of even the cheapest PLM envelope comprises a substantial part of the price of a pre-wrapped pipe. This is particularly true for smaller diameter pipes. In 1998, there was a slight upward tendency of the price of polypropylene waste fibres in The Netherlands. These fibres are no longer available in such huge quantities as they used to be in the past. Dutch pipe wrapping companies are experimenting with other synthetic waste materials in an effort to be able to market competitive envelopes in the years to come.

**TABLE 4**

**The relative cost of PLM envelopes, expressed as a percentage of the cost of the envelope plus a corrugated PVC pipe together as a prewrapped product, in The Netherlands in 1998. The cost of installation is not included. The  $O_{90}$  size is specified within brackets**

Pipe diameter (mm)	Coil length (m)	Relative cost of various envelope materials								
		Typar (270)	Coconut fibres (1000)	Polypropylene waste fibres (300)	Polypropylene waste fibres (450)	Polyester knitted sock (400)	Coconut fibres (700)	Poly-styrene beads in netting (1000)	Polypropylene fibres (700)	Polypropylene fibres (heavy) (700)
50	200	43	46	47	49	50	54	-	60	75
60	150	40	50	44	46	46	50	71*	57	73
65	150	35	39	39	41	41	46	62	52	69
80	100	33	37	39	41	41	43	-	49	65
100	100	31	40	40	42	37	43	-	47	64

\* The external diameter of the wrapped 60-mm pipe is 100 mm, i.e. the thickness of the envelope is 20 mm.

The selection of an envelope material is determined by various factors. The price is obviously important. The ease of handling of the material is also a factor of consideration. Coconut fibre envelopes will release substantial amounts of dust particles during handling and installation, particularly in dry weather; PP fibre wrapping does not. Previous favourable experiences of farmers are important: they tend to ask for a similar envelope when ordering again.

#### REVIEW OF LOCAL EXPERIENCE ON DRAINAGE MATERIALS

Adequate characterization of soil properties, field conditions (e.g. groundwater table depth) and physical properties of envelope materials is essential. In this context, the term 'problem soils' is rather vague and calls for further definition. This also holds for envelope materials: a generic description like 'PP envelope' is meaningless since it may cover the whole range from thin geotextiles to voluminous PLMs.

In an envelope selection process, a systematic comparison with experience gained elsewhere is generally very useful. Synthetic envelopes, either PLMs or geotextiles, have proven to be reliable and are successfully applied in Europe, the United States, and Canada for the last 20 years. These materials have also been used satisfactorily in large-scale field experiments in Egypt and Pakistan. In the latter country, they have also been used as envelope for interceptor drains. This proves the transferability of synthetic materials from one region to another.

In Framji *et al.* (1987), the use of envelope materials is summarized for a great number of countries. These data are included in the Table 5, which is supplemented with additional



information from other sources, included that provided by the participants of the International Course on Land Drainage (Wageningen, 1997-1999). Some local experiences that are considered to be informative are briefly discussed below.

### **Arid and semi-arid zones**

In the *Melka Sadi* Pilot drainage scheme in *Ethiopia*, trials were conducted for evaluating drainage envelopes. Three different envelopes were tested in a pilot scheme, comprising locally available red ash, gravel and a factory made fabric filter. The cost of gravel was six times that of fabric filter. The performance of both gravel and red ash were superior to that of the fabric filter (Woudeneh, 1987).

In *Egypt*, voluminous envelope materials that are produced locally, namely PP and PA waste fibres ( $O_{90}$  of 330 and 400  $\mu\text{m}$ , respectively) performed satisfactorily (Dierickx, 1992a). Occasionally, however, the wrapping of drainpipes proves to be poor. The yarn of prewrapped pipes was slack and the envelope material did not fully cover the pipe. After shipping and handling in the field, bare spots emerged at many places. In addition, taping of the envelope at either end of coils was sometimes inadequate as a result of which the envelope was loose (DRI, 1997).

In the north-western irrigation districts of *Mexico*, locally produced corrugated PE pipes are used, with a diameter of 100 mm for laterals and 150 mm for collectors. They must comply with ASTM standards (Chapter 9). Collector pipes are approximately twice as expensive as laterals. Polyester sock is used as drain envelope, the cost of which is 30 percent of the price of the wrapped pipe.

An encouraging result of recent envelope testing projects in *Pakistan* is that synthetic materials, produced in Pakistan, performed well in the laboratory and have shown their potential for field application. It is not unlikely that IWASRI will eventually recommend the Pakistan Water and Power Development Authority (WAPDA) to replace gravel envelopes with locally manufactured synthetic materials. Locally manufactured materials were found to outperform finer local and imported materials, and hence are subjected to additional field trials. In the Mardan Scarp salinity control and reclamation project in Pakistan, Dierickx *et al.* (1995) recommend envelopes with an  $O_{90}$  ranging from 200 to 400  $\mu\text{m}$ .

In *Peru*, gravel and coarse sand are available everywhere at very reasonable cost, and have been successfully installed by hand and trenching machines. The use of clay and concrete tiles has not been very successful. Many soils are very unstable, and accurate installation of drains was complicated. Installation by hand was quite slow, and the width of excavation at the soil surface was 6 to 15 times that of the trench box of a trenching machine. Concrete pipes were expensive, because they had to be made from sulphate resistant cement. Most Peruvian soils that are suitable for agriculture have a very high content of calcium sulphate. Furthermore, the rate of production of concrete pipes was quite low. Between 1983 and 1985, 400 km of 65 mm and 100 mm corrugated pipe was installed. These pipes were manufactured in Peru with an extruder, imported from Europe (De la Torre, 1987).

### **Humid Tropics**

In *Costa Rica*, corrugated pipes were imported from the United States to drain fruit plantations, mainly bananas, notably in medium to coarse sands. In finer soils with low structural stability, the pipes were mostly prewrapped with geotextiles, e.g. spun bonded polyamide (Murillo, 1987).

In **India**, drainage materials are produced locally. Agricultural drainage systems are solely installed on an experimental basis. In heavy clay soils, drains are installed without envelope material, and the systems perform satisfactorily. Locally made geotextiles are used with success; problems are rarely encountered (Oosterbaan, 1998). In the mid-1980s, the functioning of subsurface drainage systems was investigated in pilot areas, using clay tiles, installed in manually excavated trenches (Singh, 1987). In 1998, the majority of the drainage systems is still being installed by manual labour.

### Temperate zones

In **Belgium**, the use of clay tiles was discontinued in 1975 when their application was superseded by corrugated PVC pipes. Since a potential risk of mineral clogging exists in nearly all soils, envelopes are used everywhere. Envelope materials have evolved from flax straw and coconut fibres to loose synthetic fibres. Currently, loose synthetic PP fibre wrapping is almost exclusively used, but coconut fibre wrapping is still available.

In the **Scandinavian countries**, sawdust from conifer trees is very often used as an envelope material for agricultural subsurface drainage systems. In unstable soils in **Denmark** the pipe drain is protected against mineral clogging by a synthetic sheet beneath the pipe, and gravel or sawdust aside and on top of the pipe. In **Norway**, 50 percent of the sawdust has usually decayed after 20 years. Still, some drains have a service life of over 30 years, which will be due to the low temperatures in Scandinavia. The sawdust is applied in a 50 to 70 mm thick layer (Mortensen, 1987).

Approximately 60 percent of the installed drainpipes in the then **West-Germany** were prewrapped (Eggelsmann, 1982). Organic envelopes like peat, rye straw and coconut fibre wrappings have been extensively used. Even envelopes made from tannin-containing wood chips to prevent or reduce ochre formation have been developed (Eggelsmann, 1978). Various kinds of synthetic fibre and granule wrappings have been applied, yet geotextile and loose PP fibre wrappings are the most widely used materials.

Only 5 percent of the drainpipes installed in **France** need an envelope material. Envelopes have evolved simultaneously with drainpipes and drainage mechanization. Originally, coconut fibre wrappings have been widely used. The risk of microbiological decay of the coconut fibre wrapping has prompted the introduction of loose synthetic fibre wrappings and, at a later stage, geotextiles. Currently, geotextiles are used almost exclusively (Lennoz-Gratin, 1987).

In **The Netherlands**, the recommendations for the selection of PLMs are as follows (Huinink, 1992; Van Zeijts, 1992):

- Envelopes containing peat fibres and 'PP-450' should not be used in case of possible iron ochre hazard and/or if the drains are also used for subsurface irrigation purposes during the summer season.
- Mature or 'ripened' clay soils with a clay content greater than 25 percent do not require envelopes.
- For most other soils, such as immature clay soils with a clay content greater than 25 percent, (loamy) sand, (sandy) loam, silt loam and peat soils, any envelope may be selected following the recommendations, specified in Table 6.
- Exceptions are made for clay soils with a clay content below 25 percent, silts and very fine sands which should be drained with 'PP-450' or, in case of iron ochre, with 'PP-700' only.



**TABLE 6**  
**Applicability of the most popular prewrapped drain envelopes in The Netherlands** (adapted from Huinink, 1992)

Envelope material	Soil type <sup>1</sup>						
	Soils with clay content > 25% down to drain depth		Soils with clay content <25%, loams and very fine-textured soils, structurally unstable sands (median particle diameter < 120 µm)		Loamy sands and eolic deposits	Sandy soils (median particle diameter > 120 µm)	Peaty soils and peats with clayey topsoils
	Soil profile matured to drain depth?						
	Yes	No	Yes	No			
<b>'voluminous' envelopes</b> (i.e. thickness ≥ 1mm)							
Cocos ( $O_{90} = 700$ or $1000 \mu\text{m}$ )	None <sup>2</sup>	Yes			Yes	Yes	Yes
Peat/cocos mix, peat fibres	None <sup>2</sup>	Yes <sup>3</sup>			Yes <sup>3</sup>	Yes <sup>3</sup>	Yes <sup>3</sup>
Polypropylene fibres 450 µm	None <sup>2</sup>	Yes <sup>3</sup>	Yes <sup>3</sup>	Yes <sup>3</sup>	Yes <sup>3</sup>	Yes <sup>3</sup>	Yes <sup>3</sup>
Polypropylene fibres 700 µm	None <sup>2</sup>	Yes	-- <sup>4</sup>	-- <sup>4</sup>	Yes	Yes	Yes
Polystyrene beads	None <sup>2</sup>	Yes			Yes	Yes	Yes
<b>'thin' envelopes</b> (i.e. thickness < 1mm)							
Glass fibre sheet, Cerex, Typar, knitted sock envelope	None <sup>2</sup>		Yes <sup>3,5</sup>			Yes <sup>3,5</sup>	

<sup>1</sup> In layered soil profiles, envelope selection should be based on the layer with the lowest clay content.

<sup>2</sup> No envelope required; soil is structurally stable and the risk of mineral clogging of the drainpipe is small.

<sup>3</sup> Do not install this envelope material if there is a risk of iron ochre clogging, or if the drains are used for controlled drainage or for subirrigation purposes.

<sup>4</sup> Use this envelope material only if there is a serious threat of iron ochre clogging the drains.

<sup>5</sup> Do not use a thin envelope if the soil profile to drain depth contains peaty layers.

In The Netherlands, 'thin' envelope materials are used with great caution only, and only in highly unstable very fine sandy soils (median soil particle diameter < 120 µm). For a variety of reasons, this category of envelopes has never become very popular. The price of thin envelopes is not competitive, and most farmers simply prefer envelopes to have a 'visible and substantial thickness' because they are convinced that such envelopes provide better service than thin ones. Reliable data, retrieved from pilot area research projects that convincingly prove that this 'traditional' viewpoint is not always justified, have not had an appreciable effect. *Tradition is indeed a strong factor when it comes to selecting drainage materials, particularly envelopes.*

In the Marismas area, located in the Guadalquivir estuary in southern *Spain*, clay pipes are mainly used although corrugated plastic pipes are installed as well. The clay pipes have an inside diameter of 80 mm, yet a square outside circumference with a small longitudinal hole in each corner, which is introduced to assure thorough heating of the clay during the manufacturing process. The corrugated PVC drains have a diameter of 50 mm. The cost difference between clay and PVC drains is small, and farmers, therefore, prefer the larger diameter clay pipes (Martínez Beltrán, 1987). Drains are installed during the dry season when the groundwater table is below drain level. Drains do not require envelopes because the Marismas soils are very stable due to their clay content greater than 65 percent. Mineral clogging of drainpipes has never been observed except for drains whose outlets into open collectors were submerged during periods of heavy rainfall.

In silty loams and loamy clay soils of the Ebro basin in north-eastern *Spain*, corrugated PVC drains with coconut fibre wrapping have been installed in the seventies. There is no information on the performance of these drainage materials. Corrugated PVC drains and synthetic fibre wrapping have been used in the sandy soils of the Ebro delta as well.



## Chapter 4

# Water flow into and inside the drain

### FLOW TOWARDS THE DRAIN

According to Ernst (1954), the flow towards a subsurface drain can be described by a vertical flow (from the groundwater level downward to drain level), a horizontal flow towards the vicinity of the drain, a radial flow to the drain and an entry into it. Each of these flows is subject to a corresponding *resistance* (Figure 22a). For steady-state flow, the total resistance can thus be roughly classified into vertical, horizontal, radial, and entrance resistances. These resistances can be measured by strategically located piezometers (Figure 22b). Piezometers consist of unperforated narrow pipes with a short filter at the bottom end in which the water level represents the hydraulic head in the soil near the filter end. Differences in heads are a measure of the resistances mentioned. The total loss of head,  $h_p$ , is the sum of all differences indicated in Figure 22b:

- The *vertical head loss*,  $h_v$ , is the difference in water level between piezometers 1 and 2, located midway between two drains, with filters at respectively groundwater level and drain depth.
- The *horizontal head loss*,  $h_h$ , due to (mainly) horizontal flow towards the drain, is the difference in water level between piezometers 2 and 3, with filters at drain level respectively midway between two drains and in the vicinity of the drain.

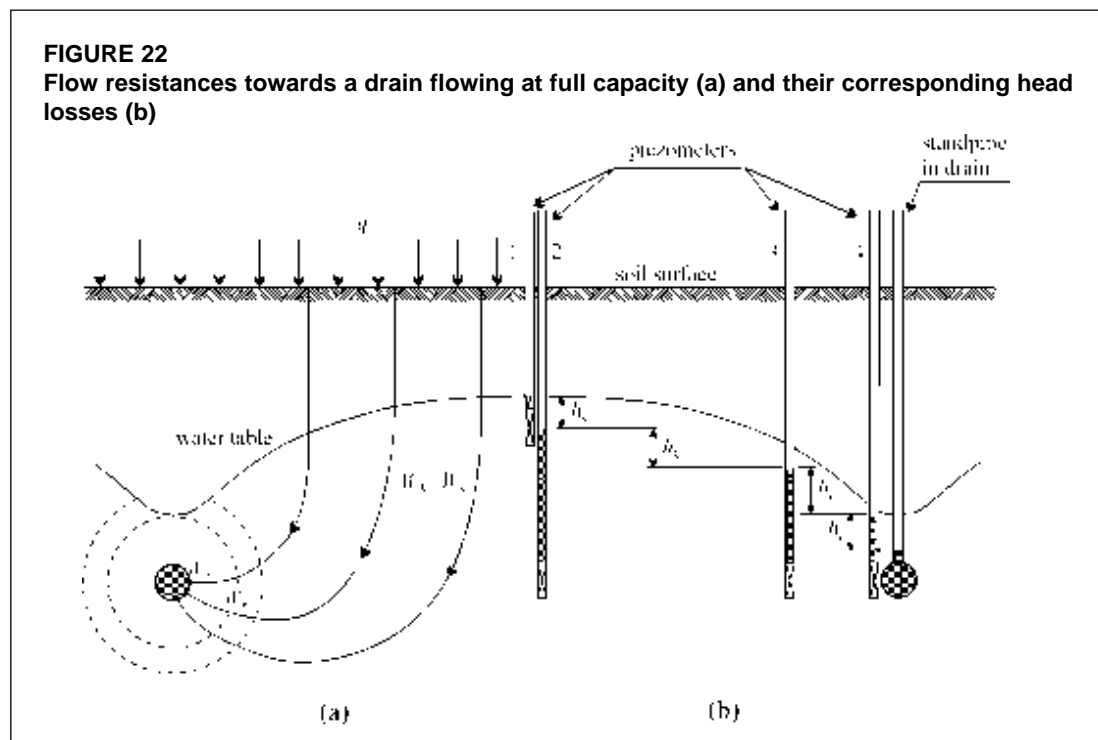

- The *radial head loss*,  $h_r$ , is the difference in water level between piezometers 3 and 4, with filters at drain level respectively some distance away from the drain and at the drain.
- The *entrance head loss*,  $h_e$ , is the difference in water level between piezometer 4 and an open standpipe in the drain.

The relationship between head loss and corresponding resistance is given by:

$$h_* = q L W_* \quad (1)$$

where  $h$  = difference in head (m);

$L$  = drain spacing (m);

$q$  = specific discharge (m/d);

$W$  = resistance (d/m); and

\* = subscript  $v$  (vertical),  $h$  (horizontal),  $r$  (radial),  $e$  (entry) or  $t$  (total).

Thus the total head loss is:

$$h_t = h_v + h_h + h_r + h_e \quad (2)$$

Sometimes the resistances  $W$  are replaced by the dimensionless quantities  $\alpha$  which are independent of the hydraulic conductivity of the soil:

$$\alpha_* = K_* W_* \quad \text{or} \quad W_* = \alpha_* / K_* \quad (3)$$

where  $K$  = hydraulic conductivity (m/d); and

$\alpha$  = geometrical factor (dimensionless).

Hence, the total head is given by:

$$h_t = q L (W_v + W_h + W_r + W_e) = q L (\alpha_v / K_v + \alpha_h / K_h + \alpha_r / K_r + \alpha_e / K_e) \quad (4)$$

This and other drainage theories are used for calculating drain spacings. They are based on a set of assumptions concerning the drain and the physical properties of the soils involved. Although these assumptions are approximate, the outcome is usually sufficient for practical applications. One of these assumption is that of an 'ideal drain', without entrance resistance, whereby the drain is considered as an equipotential. Generally, it is assumed that the drain surround (envelope material and loosened soil in the trench) has such a high hydraulic conductivity compared to the undisturbed soil, that the entrance resistance may be neglected. Practical experience has shown that this cannot always be taken for granted. There is still need for a query, both theoretically and empirically, in which cases substantial entrance resistances may be encountered.

Ponding and excess soil water during heavy rains, in spite of the presence of a drainage system, may also result from a low permeability layer near the soil surface that causes a suspended or perched water table. Another cause may be compaction due to heavy machinery, to slaking during heavy rains and, on sports fields, to playing actions. This low permeability layer simply prevents the water from reaching the groundwater table, but has nothing to do with the subsurface drainage system itself.

Procedures and programs for the design of subsurface drainage systems are in preparation by FAO. Therefore, this analysis will be limited to the influence of the entrance resistance and pipe flow on drain performance.

### ENTRANCE AND APPROACH FLOW RESISTANCE

Water enters a real drain through a finite number of perforations, which represent at most only 1 to 2 percent of the total wall area. Although a real drain does not alter the general radial flow pattern, the streamlines converge to the inlet perforations in the immediate vicinity of the drain. This causes an *entrance resistance*,  $W_e$ , leading to a head loss on entry,  $h_e$ .

As compared to flow to an imaginary, ideal drain, the convergence of streamlines to the inlet perforations of a real drain invokes an additional flow resistance and head loss. The additional flow resistance is called entrance resistance and the corresponding head loss is the entrance head loss.

According to Eq. (1) and taking into account Eq. (3) the relationship between entrance head loss and entrance resistance is given by:

$$h_e = qLW_e = \frac{qL}{K_e} \alpha_e \quad (5)$$

The entrance resistance of a real drain can be calculated theoretically for some simple perforation shapes and patterns, or can be obtained if the flow pattern towards both the ideal and real drain can be accurately modelled (Section *Entrance resistance of drainpipes*). In most cases, the entrance resistance is obtained empirically from the entrance head loss. Theoretically, the entrance head loss can be obtained directly from piezometer readings outside and inside the drain (Figure 22b). Practically, however, piezometer 4 will be placed at some short distance away from the drain to avoid the disturbance of the soil caused by installing the drain (Figure 23) and therefore, the measured head loss involves not only the entrance head loss, but also part of the radial resistance.

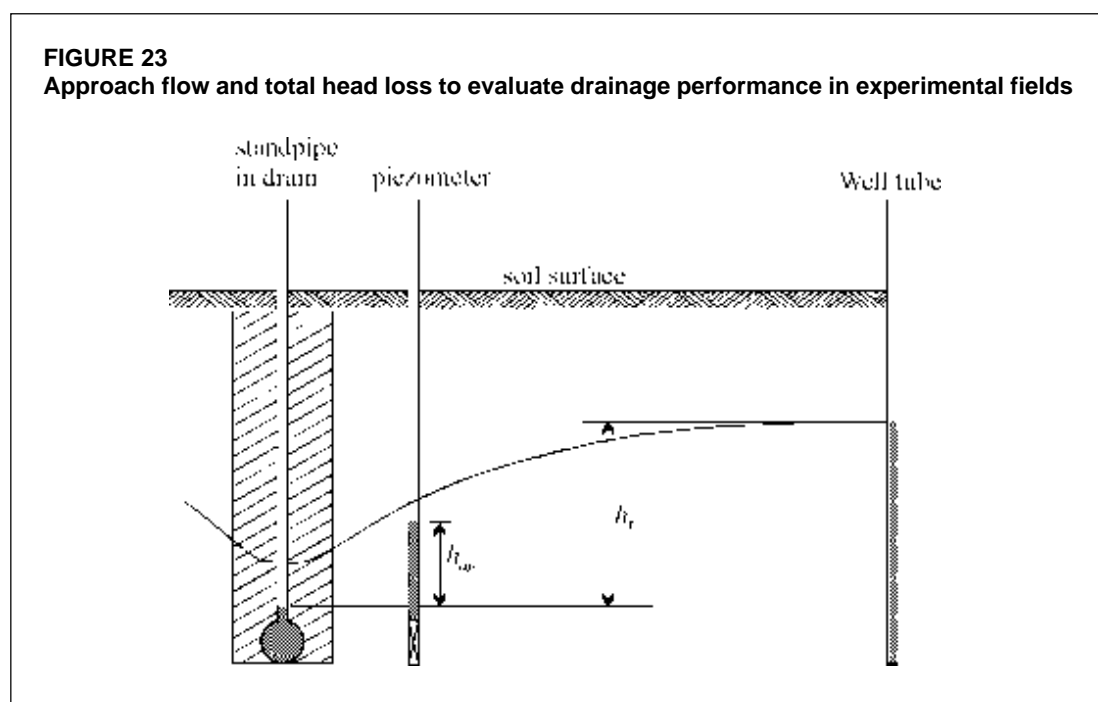

Entrance resistance, resistance of the disturbed soil and the radial resistance are theoretical concepts, which cannot be physically separated, nor separately measured in the field. The measured head loss is the ‘lump sum’ of all the head losses which may be theoretically considered in the approach flow region.

Cavelaars (1967) introduced the concept of ‘approach flow resistance’ ( $W_{ap}$ ) and ‘approach flow head loss’ ( $h_{ap}$ ) for the flow in the approach region (Figure 23). Similar to Eq. (5), the relationship between both quantities for approach flow can be written as:

$$h_{ap} = qLW_{ap} = \frac{qL}{K_{ap}}\alpha_{ap} \quad (6)$$

The measured head,  $h_{ap}$ , results from entrance resistance, resistance of the disturbed soil surrounding the drain, and the radial resistance in the undisturbed soil as shown in Figure 24 for a drain installed in a trench. This also holds for trenchless drainpipe installation, but the disturbed zone will not be so clearly bounded compared to that created by a trencher.

**FIGURE 24**  
**Drain with or without envelope, disturbed trench backfill and undisturbed soil constitute the approach flow region**

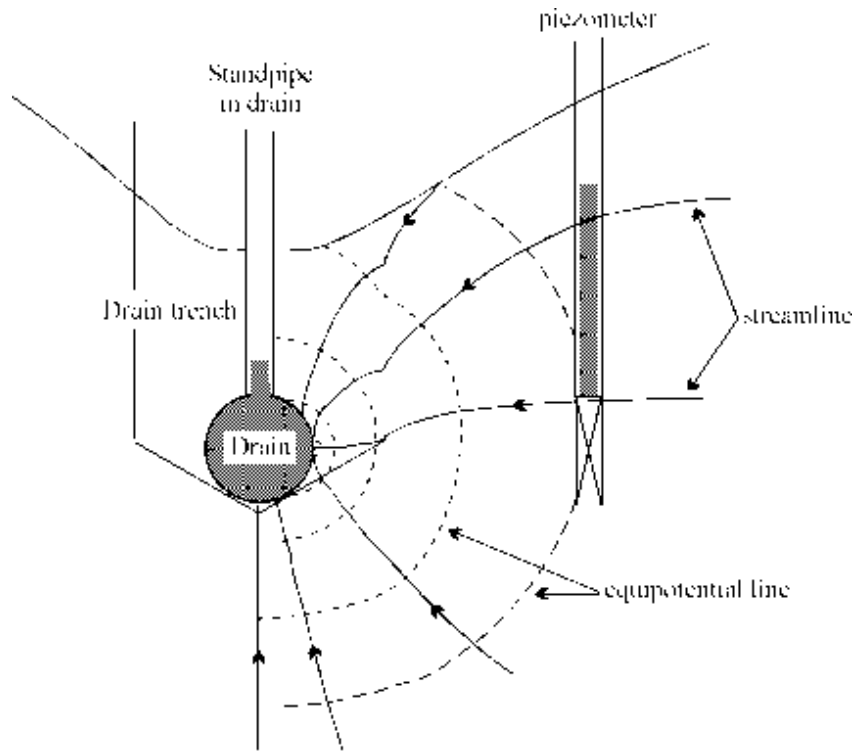

The head loss determined in experimental fields is the approach flow head loss, though it is usually called ‘entrance head loss’, and is used to calculate the ‘entrance resistance’, e.g. by Dieleman and Trafford (FAO, 1976).

The entrance resistance as defined by Dieleman and Trafford (FAO, 1976) is in fact an approach flow resistance and differs fundamentally from the theoretical concept of entrance resistance.

It can also be useful to express the approach flow head loss as a percentage of the total head loss. To determine the total head loss, either a piezometer (piezometer 1) as in Figure 22b or a well tube as in Figure 23 can be installed midway between drains. Unlike the piezometer, which is perforated at the bottom over a limited length only, the well tube is perforated over almost its entire length.

The flow pattern near the drain is very complex due to the disturbed soil where physical characteristics are heterogeneous and change with time and are therefore difficult to predict. The approach flow head loss,  $h_{ap}$ , is affected by the physical properties of this disturbed soil which surrounds the drain ( $K_{ap}$ ), the drain spacing and the drainage materials used. A good envelope material, however, can reduce  $\alpha_{ap}$  to such low values that the drain will act as almost an ideal drain.

The same holds if the soil around the drain is highly permeable, say  $K_{ap} = 10$  m/d. This is mostly the case in backfilled trenches in clayey soils or after trenchless drainage in well-structured clays and clay-loams. Thus, entrance resistance is seldom a problem in these soils, even in the absence of a drain envelope. The reason for this behaviour is that water in the immediate vicinity of the drainpipe often follows preferential pathways. It will be routed through either the trench backfill, if present, or through cracks and fissures, created by a trenchless drainage machine. The occurrence of preferential flow is determined by the conductivity ratio of the disturbed and the undisturbed soil. The disturbed soil may have a permanently higher hydraulic conductivity. Yet after settling, some disturbed soils may become less permeable than the undisturbed soil. Soil disturbed in dry conditions will in most cases favourably affect drainage performance, regardless of whether the soil is homogeneous or heterogeneous, and whether the water follows preferential flow paths or not.

Any effective subsurface drainage system requires good physical soil conditions in the immediate vicinity of the drain. Only then will drainage materials, which are by themselves appropriate, do a good job. In this context, '*good physical soil conditions*' is synonymous with a physically stable and hydraulically permeable soil. Such a soil, which consists of stable soil aggregates is often referred to as a '*well-structured soil*'.

The installation of subsurface drains causes major changes in the physical properties of soil material abutting the drain. These properties are difficult to quantify, mainly because they cannot be accurately observed. Still, the physical properties of the soil are crucial for the future success or the failure of the drainage system. After installation, a balance has to be re-established, as the soil will settle around the drain in some way or another. The major force that governs this process is the drag force of the flowing groundwater that is discharging into the drain. The forces between soil particles and aggregates that resist this drag force are also important. Furthermore, the retentive property of the pipe or the drain envelope plays an important role. Depending on the way the drains were installed (trencher or trenchless), the structure of the soil around the drain will be 'damaged', that is, weakened. Consequently, the natural ability of the soil to resist the detrimental forces of the groundwater will be undermined. An additional complicating factor is the fact that the flux density of the groundwater is the highest where the structural stability of the soil is often weakest, namely near the drain, where the flow converges.

The soil may be locally compacted, especially when drains are laid under wet conditions. If drains are installed with a trenchless machine, which employs a vertical plough, the detrimental effect on the structure of the soil depends on the depth of installation and the soil water content at the time of installation. Up to a certain depth, the plough is able to lift the soil, creating fissures, and macropores. Yet, below the so-called critical depth the overburden of the soil prevents it from being lifted. Instead, the soil is pushed aside, compacted and smeared and natural fissures and macropores are locally destroyed (Van Zeijts and Naarding, 1990).

## WATER FLOW INTO THE DRAINPIPE

### The exit gradient

Darcy's law describes the flow of water through porous media under laminar flow conditions and expresses the proportionality between the discharge over a cross-section and the hydraulic head loss, or between the discharge and the hydraulic gradient:

$$Q = KA \frac{dh}{dl} = KAi \quad (7)$$

where  $Q$  = discharge (m<sup>3</sup>/d);

$A$  = area of cross-section (m<sup>2</sup>);

$K$  = hydraulic conductivity (m/d);

$dh$  = hydraulic head loss (m);

$dl$  = distance over which  $dh$  is measured (m); and

$i$  = hydraulic gradient or head loss per unit of distance (=  $dh/dl$ ).

The exit gradient  $i_{ex}$  is the hydraulic gradient at which water leaves one medium and enters another. The flow media at the interface may be soil-water, soil-air, soil-envelope, envelope-water, or envelope-air. When the water enters the drain, the medium it leaves can be the soil or the envelope material. The medium it enters may be water or air.

If the streamlines are parallel (Figure 25), the hydraulic gradient  $i$  is given by:

$$i = \frac{\Delta h}{\Delta l} = \frac{Q}{AK} \quad (8)$$

In this case, for a given  $Q$ , the hydraulic gradient  $i$  is the same anywhere in the flow region since  $A$  and  $K$  are constants. Thus, the exit gradient  $i_{ex}$  or the gradient where the water leaves the soil is equal to the hydraulic gradient throughout the system, which is a constant.

However, in case of radial flow (Figure 26), the cross sectional area per unit drain length at a distance  $r$  from the drain centre is  $2\pi r$  and the streamlines converge. The discharge per unit drain length is given by:

$$qL = 2\pi rK \frac{dh}{dr} \quad (9)$$

and the hydraulic gradient by:

$$i = \frac{dh}{dr} = \frac{qL}{2\pi rK} \quad (10)$$



**FIGURE 25**  
Horizontal flow

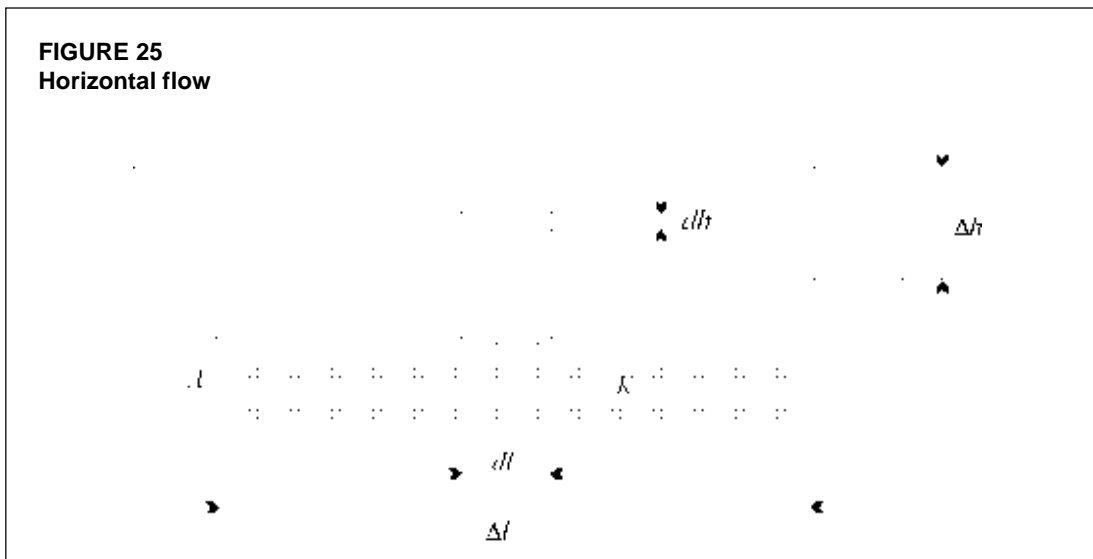

where  $q$  is the specific discharge (for steady state flow equal to rainfall or irrigation excess in m/d),  $L$  the drain spacing (m), and  $qL$  the discharge per unit drain length ( $\text{m}^2/\text{d}$ ). In this case, the hydraulic gradient  $i$  is no longer a constant for a given discharge per unit drain length, but increases with decreasing  $r$  and vice versa.

Considering radial flow towards an ideal drain, i.e. a completely permeable drain, the exit gradient  $i_{ex}$  where the water leaves the soil and enters the drain will be greater than anywhere else in the flow system. It is inversely proportional to the drain radius (Figure 27). For non-ideal drainpipes, the flow lines further converge toward the perforations in the drain wall, so that the exit gradient at the drain perforations will be even greater. However, an ideal drain with a smaller diameter  $r_o$  can 'replace' a perforated real drain in drain spacing calculations (Section *Plain drain*). In theory, the exit gradient at the boundary of such a hypothetical (and smaller) ideal drain equals the exit gradient at the perforations of a real drain.

The concept of radial flow is based upon simplifying assumptions concerning the real situation. Usually, however, the flow pattern near a drain is not fully radial; it may indeed be very different, e.g. irregular, depending on the hydraulic properties of the soil near the drain. Hence, the equipotentials in the groundwater are not necessarily concentric, relative to the drain centre. Instead, they are more likely to be eccentric and even irregular. This fact often complicates the assessment of the actual exit gradient in real situations.

### The critical hydraulic gradient

Flow of water at a high exit gradient is rapid and powerful. It may exert enough drag force to overcome the resistance of the soil against shear. In this case, movement of soil particles will

**FIGURE 26**  
Radial flow

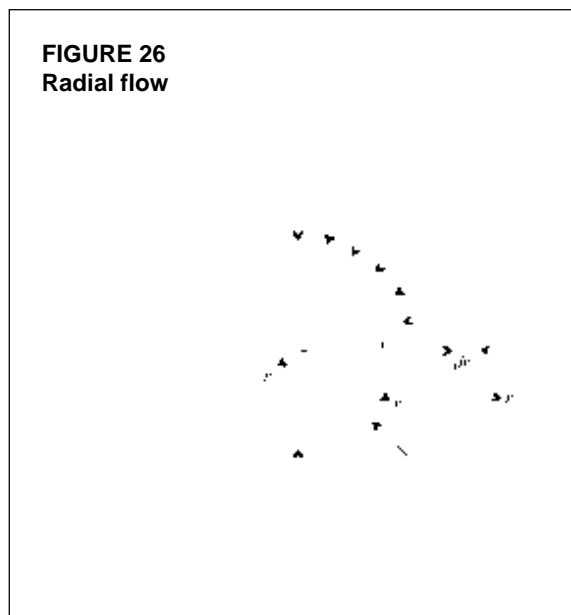

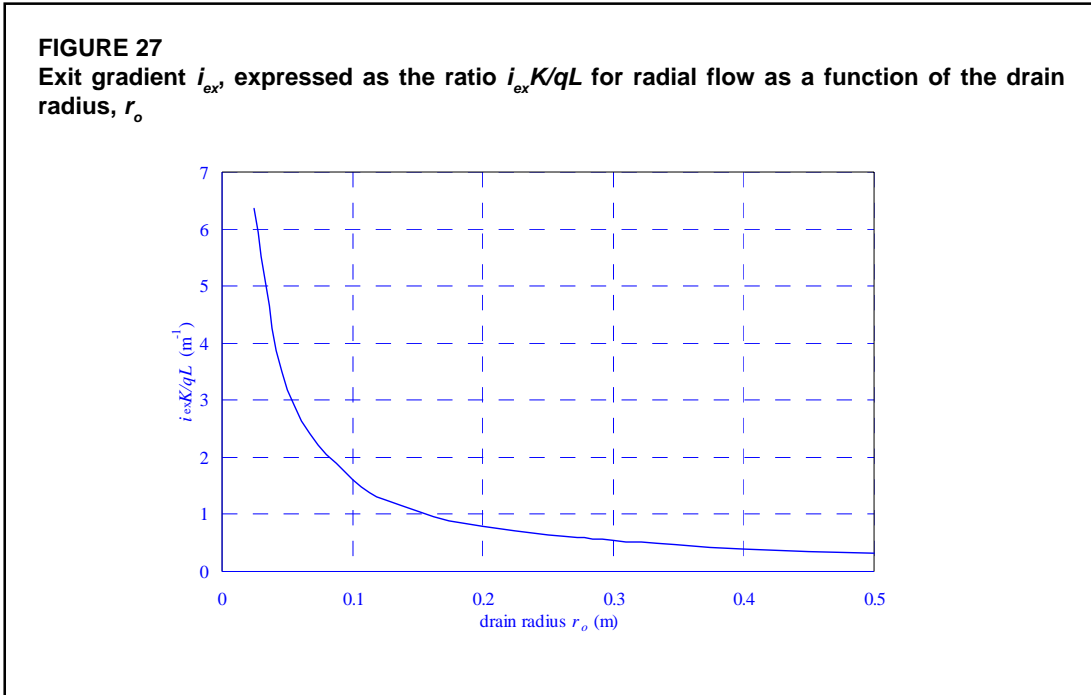

start and local erosion will occur around the drain. The hydraulic gradient at which these phenomena occur, is called *critical hydraulic gradient*.

The shearing resistance of a soil, which opposes the movement of soil particles or soil erosion, is given by Coulomb's equation:

$$\tau_f = c_o + \sigma_e \tan \phi \quad (11)$$

where  $\tau_f$  = shearing resistance per unit area (Pa);  
 $c_o$  = cohesion (Pa);  
 $\sigma_e$  = effective stress of the soil particles or intergranular stress (Pa); and  
 $\phi$  = angle of internal friction or shearing resistance.

Cohesive soils (like clays) possess firm bonds between soil particles and are mostly composed of soil aggregates. Cohesionless soils (like sands) lack bonds between individual particles ( $c_o = 0$ ) and consist of individual soil particles, hence:

$$\tau_f = \sigma_e \tan \phi \quad (12)$$

Soil load and water pressure determine intergranular stresses  $\sigma_e$ . Greater soil loads and smaller water pressure increase the effective stress and reduce the risk of erosion. However, stable bridges may occur in sands. They form arches, that span about 5-8 grain diameters (Peschl, 1969). Sand, therefore, does not normally enter openings less than 5-8 grain diameters (except for a few grains that escape while the arches are being established).

Water flowing through a porous medium exerts a pressure on the soil particles in the direction of movement. This pressure is called *flow pressure*. If the flow pressure acts in the direction of gravity (downward flow) the effective stress of the soil particles is increased and the risk of erosion is lessened. If however the flow pressure acts against gravity (upward flow) the

intergranular stress may decrease substantially or even be cancelled, resulting in a highly unstable situation which is known as 'quick sand'. Examples of such flows are 'mud volcanoes' being formed in places of strong upward water movement. Flow pressure perpendicular to gravity causes a lateral movement of soil particles when the shear resistance is overcome. The hydraulic gradient at which the structural strength of the soil becomes negligible is called the *critical gradient*,  $i_c$ .

The critical gradient depends on the effective stress and on the cohesion of the soil. For cohesionless soils without soil load, the critical hydraulic gradient equals approximately unity. This situation occurs in case of upward flow of groundwater. For cohesive soils, the cohesive force has to be considered as well. For these soils, the critical hydraulic gradient will be greater than that of cohesionless soils. It is related to the strength of the cohesive bonds between soil particles and/or aggregates.

If the flow pressure exceeds the shearing resistance of the soil, erosion will occur because the soil loses its structural strength. Since the flow pressure is proportional to the acting hydraulic gradient, erosion will start as soon as the exit hydraulic gradient  $i_{ex}$  reaches the critical hydraulic gradient  $i_c$  of the soil (Terzaghi and Peck, 1965).

Internal erosion in which soil particles move in the soil itself is not considered. It usually occurs in alkali soils, especially when the soil reacts on phenolphthalein ( $pH$  above 8.5). In such soils, internal erosion may occur if fine soil particles can detach themselves from the skeleton formed by the coarser fractions. With the water flow, they move through cracks and other macropores in the soil. This may cause a turbid drain outflow, resulting in a 'milky' appearance of such waters and internal clogging of the soil skeleton.

### Hydraulic failure gradient

The critical hydraulic gradient will be greater in case of overburden load and with increasing soil cohesion. In accordance to these assumptions, Samani and Willardson (1981) have proposed the concept of the *hydraulic failure gradient*,  $i_f$ , which is the hydraulic gradient at which a confined or supported soil cannot resist the drag force of the flowing water. The soil loses its structural stability and starts moving into, and possibly through envelopes. Then the drainage system is very likely to fail because this process may substantially reduce the hydraulic conductivity of the envelope.

Samani and Willardson (1981) found that the hydraulic failure gradient depends on the plasticity index of a soil (Chapter 6). The associated relationship was however not transferable between soils originating from humid and arid regions. Yet, if the hydraulic conductivity is incorporated in the  $i_f$ -concept a good correlation was found between the hydraulic failure gradient and the combination of plasticity index and hydraulic conductivity of the soil. This correlation was valid both for humid and arid regions. Vlotman *et al.* (in press) used the data of Samani and Willardson (1981) to derive an empirical relationship, which is only slightly different from the original one:

$$i_f = e^{(0.332-1.14K+1.07 \ln I_p)} \quad (13)$$

where  $i_f$  = hydraulic failure gradient;  
 $K$  = hydraulic conductivity of the soil (m/d); and  
 $I_p$  = plasticity index of the soil.

The plasticity index is a measure for the plasticity of a soil. It is defined as the difference in water content, as a percentage of the mass of oven-dried soil, of a soil at its liquid limit and at its plastic limit (ICID, 1996):

$$I_p = 100(W_{LL} - W_{PL})/W_{DS} \quad (14)$$

where  $W_{LL}$  = mass of soil sample at liquid limit (g);  
 $W_{PL}$  = mass of soil sample at plastic limit (g); and  
 $W_{DS}$  = mass of oven-dried soil sample (g).

Eq. (13) considers however only soil properties. Overburden effects and envelope types are not considered, otherwise  $i_f$  cannot be constant for a given soil condition. Therefore the  $i_f$ -concept is, in essence, the same as the critical hydraulic gradient.

The  $i_f$ -concept can be useful as a decision tool for the application of a voluminous envelope to increase the radius  $r$  and so to reduce the exit gradient  $i_{ex}$  near the drain to a value inferior to the  $i_f$ -value of the soil. Still, the  $i_f$ -concept has never found widespread application. The experience obtained so far with the  $i_f$  as a tool for drain envelope design is therefore very limited.

#### ENTRANCE RESISTANCE OF DRAINPIPES

In the section *Entrance and approach flow resistance*, it was established that the head loss which is observed near a field drain is associated with the *approach flow resistance*, which is the *lump sum* of the *entrance resistance* and the *flow resistance* in the adjacent soil. Hence, the effect of (wrapped) subsurface drains on drainage performance cannot be determined as such. It is, however, important that the hydraulic properties of drainpipes and envelopes on drainage performance can be assessed as well. These properties are therefore discussed in this section.

#### Plain drain

The flow towards a drain can be established if this flow can be modelled analytically. This can be done for radial flow. The head loss, associated with radial flow to an ideal, full flowing drain in a homogeneous and isotropic soil (Figure 28a) with hydraulic conductivity  $K$ , reads:

$$h_r = qLW_r = \frac{qL}{K}\alpha_r = \frac{qL}{2\pi K} \ln \frac{r}{r_o} \quad (15)$$

in which:

$$\alpha_r = \frac{1}{2\pi} \ln \frac{r}{r_o} \quad (16)$$

where  $r$  = the radius of a circular equipotential (m); and  
 $r_o$  = the radius of the ideal drain (m).

The radius  $r$  should be chosen such that the equipotential has indeed a circular shape, and the flow towards the drain is radial. That is, the effect of the pipe perforations on the chosen equipotential must be insignificant. The approach flow head loss, associated with radial flow to a *real drain* (Figure 28b) is given by Eq. (6) which can also be written as:

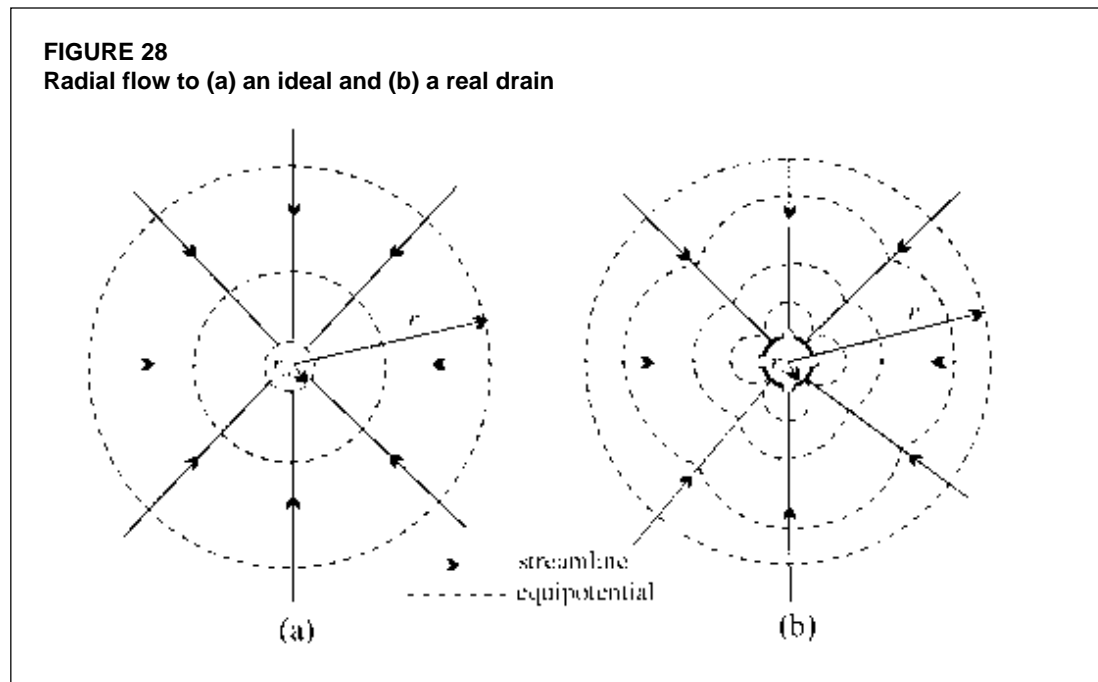

$$h_{ap} = qL(W_r + W_e) = \frac{qL}{K}(\alpha_e + \alpha_r) \quad (17)$$

Since radial flow to an ideal drain is described by Eq. (16) the entrance resistance results from:

$$\alpha_e = \alpha_{ap} - \alpha_r \quad (18)$$

In this case, the entrance resistance of a *real drain* is the difference between the approach flow resistance to a real drain and the radial flow resistance to an *ideal drain*.

The entrance resistance  $\alpha_e$  is fully associated with the drainpipe and therefore is a constant dependent on the perforation shape and pattern of the drainpipe if the radial flow occurs over the whole drain circumference. If radial flow occurs over only a section of the drain circumference (Figure 29), the flow resistance depends on the sector area where the radial flow to the drainpipe really occurs (Boumans, 1963). The actual entrance resistance,  $\alpha_e^*$ , is inversely proportional to the flow sector:

$$\alpha_e^* = \frac{2\pi}{\beta} \alpha_e \quad (19)$$

where  $\beta$  = angle of the sector where radial flow occurs (radians, 0-2 $\pi$ ).

The transitional boundary of the soil with the pipe perforations also affects the entrance resistance since the entrance resistance is invoked by the convergence of streamlines to these perforations. The entrance resistance increases due to any type of clogging, and decreases because of the washing out of soil particles. The boundary between soil and pipe perforations may have manifold geometrical configurations. The following boundaries may exist (Figure 30):

- the perforations are filled with soil;
- the soil forms a plane boundary with the perforations (plane boundary conditions);

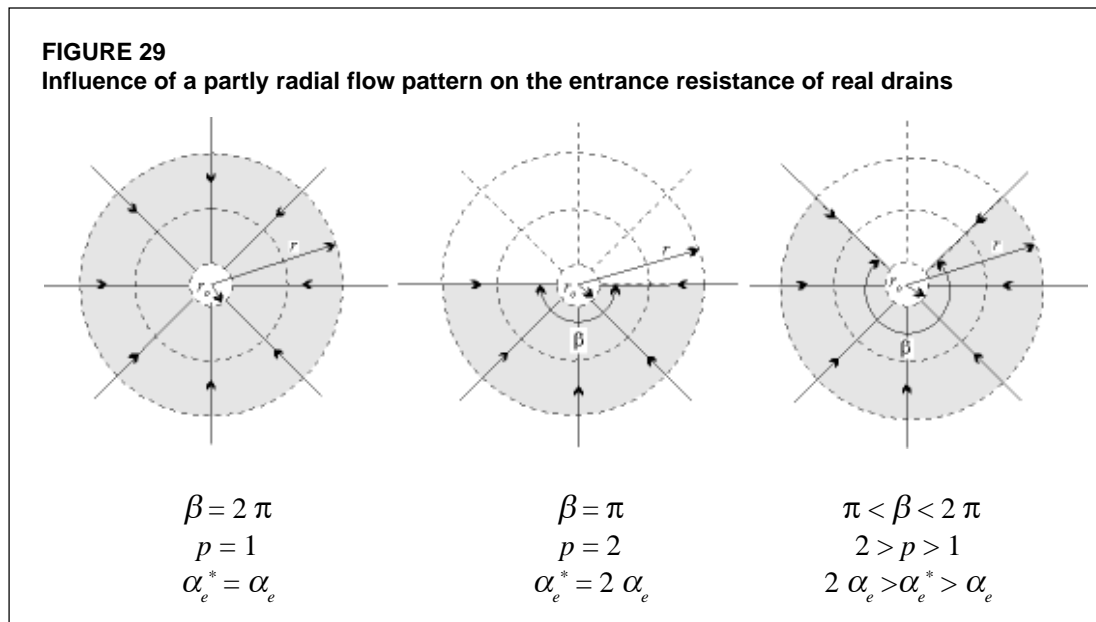

- the soil near the perforations is washed out and forms an arched boundary (arched boundary conditions); and
- the soil near the perforations is washed out and forms an irregular boundary.

In the field, the arched boundary is the most likely configuration (Peschl, 1969). According to Stuyt (1992a) this boundary may have a more complex three-dimensional configuration. The openings shown in Figure 30 may represent either:

- gaps between tile drains;
- circular perforations in plastic pipes; and
- rectangular slots in plastic pipes.

The shape of the outer pipe wall (smooth or corrugated) affects the entrance resistance, especially if the perforations lie in the valley of the corrugations which is normally the case. The greatest effect stems from whether the corrugations are filled with soil or not. If the corrugations are filled with soil, the geometry of the boundary of the soil with the perforations is quite relevant. For corrugations without soil the boundary with the corrugations will be decisive for the entrance resistance. The shape of the corrugations ('wave' or 'block') exerts only a minor influence.

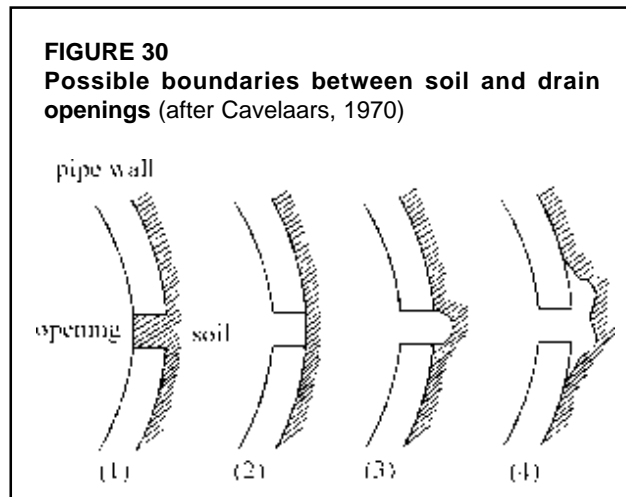

For some patterns and shapes of perforations in smooth outer pipe walls, the entrance resistance can be modelled analytically for plain and arched boundary conditions. Dierickx (1980) made an extensive review of the analytical solutions and checked their correctness with an electrolytic model. The simplest but still sufficiently accurate solutions are summarized in

Dierickx (1999). In many cases however, and for corrugated drains, the entrance resistance follows from model research. Accurate results can be obtained with an electrolytic model since both boundary conditions and hydraulic conductivity are known very accurately. This is not the case when sand models are used, because the configurations are less well defined.

Analytical solutions and model research have revealed that for *circumferential openings* between clay and concrete tiles, the entrance resistance is largely related to the gap spacing and the outer drain diameter and only slightly to the gap width. Thus, increasing gap width between tiles is an ineffective way to reduce the entrance resistance while the risk of soil invasion is enhanced. The provision of segmented pipes with holes also reduces the entrance resistance. Such pipes are used exclusively in the United States. Because the gap spacing of *tile drains* cannot be reduced, the only way to decrease their entrance resistance is the use of a larger diameter tile.

The most effective way to decrease the entrance resistance of drainpipes with *circular perforations* is to increase the number and diameter of the perforations. Although drains with *continuous longitudinal slits* do not exist, their properties can be simulated in mathematical models. As such, investigation of their properties is useful: increasing the number of slits is more effective than increasing the slit width and the drain diameter. Hence, increasing the number of slit rows is the most effective way to reduce the entrance resistance of drains with *discontinuous longitudinal slits*. The entrance resistance of drains with *discontinuous circumferential slits* can be reduced by decreasing the spacing between the rows of slits and by increasing the drain diameter. The slit width is less important.

According to Childs and Youngs (1958), a real drain can be replaced by an ideal drain with a smaller radius, the so-called *equivalent* or *effective radius*,  $r_{ef}$ . Substitution of  $\alpha_r$  from Eq. (16) into Eq. (18) yields:

$$\alpha_{ap} = \frac{1}{2\pi} \ln \frac{r}{r_o} + \alpha_e \quad (20)$$

Similarly to Eq. (16), the radial flow resistance for flow to the ideal substitute, which results in the same flow resistance, is given by:

$$\alpha_{ap} = \frac{1}{2\pi} \ln \frac{r}{r_{ef}} \quad (21)$$

from which it follows that:

$$r_{ef} = r e^{-2\pi\alpha_{ap}} = r_o e^{-2\pi\alpha_e} \quad (22)$$

As the effective radius depends on the entrance resistance, the effective radius can be used as an alternative to the entrance resistance: the smaller the entrance resistance, the larger the effective radius.

Values of entrance resistances associated with various drainpipes are given in Table 7. The values of Dierickx (1993) result from electrolytic model research with the assumption that the corrugations of flexible pipes are filled with soil, and that the soil forms a plane boundary with the perforations. Smedema and Rycroft (1983) do not quote any reference yet the values they present are most likely established from sand tank models. The table also contains the ratio  $r_{ef}/r_o$  ( $= e^{-2\pi\alpha_e}$ ) to show the effect of entrance resistance on the effective radius of a drain.

**TABLE 7**  
Entrance resistances and  $r_{ef}/r_o$ -ratios of plain drainpipes

Type of drainpipe	Dierickx (1993)		Smedema & Rycroft (1983)	
	$\alpha_e$ (dimensionless)	$r_{ef}/r_o$ (dimensionless)	$\alpha_e$ (dimensionless)	$r_{ef}/r_o$ (dimensionless)
Clay and concrete	1.0 – 3.0	$1.9 \cdot 10^{-3} - 6.5 \cdot 10^{-9}$	0.4 – 2.0	$8.1 \cdot 10^{-2} - 3.5 \cdot 10^{-6}$
Smooth plastic	0.6 – 1.0	$2.3 \cdot 10^{-2} - 1.9 \cdot 10^{-3}$	0.4 – 0.6	$8.1 \cdot 10^{-2} - 2.3 \cdot 10^{-2}$
Corrugated plastic	0.3 – 0.6	$1.5 \cdot 10^{-1} - 2.3 \cdot 10^{-2}$	0.05 – 0.1	$7.3 \cdot 10^{-1} - 5.3 \cdot 10^{-1}$

Although different entrance resistance values are found in the literature, segmented pipes with gaps usually have a greater entrance resistance than smooth plastic pipes with more uniformly distributed perforations. In turn, smooth plastic pipes have greater entrance resistances than corrugated plastic pipes with more perforations and a greater perforation area.

### Drain with envelope

Since the entrance resistance of drainpipes can be of the same order as the total flow resistance in the soil (Widmoser, 1968), any change of permeability in the immediate vicinity of the drain will markedly influence drainage performance. Drain envelopes normally have a greater hydraulic conductivity than the surrounding soil. Hence, they contribute to the decrease of the entrance resistance of drainpipes.

If an envelope with thickness  $d_e$  and a hydraulic conductivity  $K_e > K$  surrounds an ideal drain (Figure 31), the total radial flow resistance is given by:

$$\alpha_r = \frac{I}{2\pi} \ln \frac{r}{r_e} + \frac{I}{2\pi\kappa_e} \ln \frac{r_e}{r_o} \quad (23)$$

where  $r_e$  = radius of the soil-envelope interface (m); and

$\kappa_e = K_e/K$ , is the relative hydraulic conductivity or the hydraulic conductivity ratio of the envelope and the surrounding soil.

Defining the entrance resistance presents no particular difficulty for drains without envelopes (Section *Plain drain*). However, the entrance resistance of a drain with envelope is affected by both the hydraulic conductivity of the envelope relative to that of the surrounding soil, as well as by the envelope thickness. When an envelope is used, several definitions of the entrance resistance can be given.

#### Alternative 1

If the entrance resistance is related to the drainpipe itself, an envelope does not cause any change in the entrance resistance. Only the total flow resistance is changed. As long as the

**FIGURE 31**  
Theoretical flow towards an ideal drain surrounded by an envelope

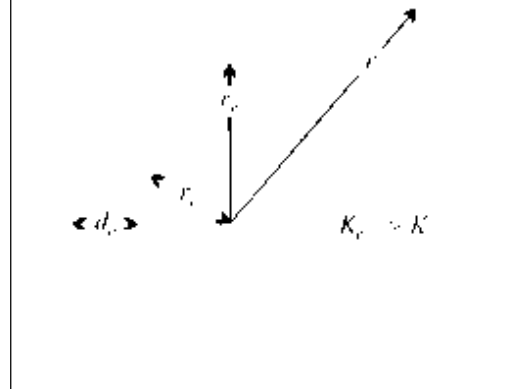



thickness and the hydraulic conductivity of an envelope allows for radial flow in the surrounding soil, the entrance resistance  $\alpha'_e$  of a drainpipe itself is given by:

$$\alpha'_e = \frac{\alpha_e}{\kappa_e} \quad (24)$$

while the radial flow resistances in the envelope and in the soil form the other components of the approach flow resistance, hence:

$$\alpha_{ap} = \frac{1}{2\pi} \ln \frac{r}{r_e} + \frac{1}{2\pi\kappa_e} \ln \frac{r_e}{r_o} + \alpha'_e \quad (25)$$

and, if the effective radius,  $r_{ef}$ , is considered:

$$\alpha_{ap} = \frac{1}{2\pi} \ln \frac{r}{r_{ef}} \quad (26)$$

Hence the effective radius becomes:

$$r_{ef} = \frac{r_o^{1/\kappa_e}}{r_e^{(1/\kappa_e)-1}} e^{-2\pi\alpha'_e} \quad (27)$$

### Alternative 2

The entrance resistance may alternatively be expressed as the resistance of both drain and its surrounding envelope. This is equal to combining the last two terms in Eq. (25) into:

$$\alpha_{e,e} = \alpha'_e + \frac{1}{2\pi\kappa_e} \ln \frac{r_e}{r_o} \quad (28)$$

The approach flow resistance now reads:

$$\alpha_{ap} = \frac{1}{2\pi} \ln \frac{r}{r_e} + \alpha_{e,e} \quad (29)$$

For an ideal drain where  $\alpha'_e = 0$ , the entrance resistance given by Eq. (28) yields the envelope resistance to radial flow. The effective radius can be calculated by combining Eqs. (26) and (29):

$$r_{ef} = r_e e^{-2\pi\alpha_{e,e}} \quad (30)$$

### Alternative 3

Widmoser (1968) defined the entrance resistance,  $\alpha_{(e,e)W}$ , as the difference in flow resistance between a drain with an envelope and an ideal drain of the same diameter,  $r_o$ . Thus:

$$\alpha_{(e,e)W} = \left( \frac{1}{2\pi} \ln \frac{r}{r_e} + \frac{1}{2\pi\kappa_e} \ln \frac{r_e}{r_o} + \alpha'_e \right) - \frac{1}{2\pi} \ln \frac{r}{r_o} \quad (31)$$

which, after some simplifications, finally results in:

$$\alpha_{(e,e)W} = \alpha'_e + \frac{1}{2\pi} \left( \frac{1}{\kappa_e} \ln \frac{r_e}{r_o} - \ln \frac{r_e}{r_o} \right) \quad (32)$$

while the approach flow resistance is given by:

$$\alpha_{ap} = \alpha_{(e,e)W} + \frac{1}{2\pi} \ln \frac{r}{r_o} \quad (33)$$

Combination of Eqs (26) and (33) yields the effective radius:

$$r_{ef} = r_o e^{-2\pi\alpha_{(e,e)W}} \quad (34)$$

Though Widmoser (1968) might have given the right definition on the entrance resistance of a drain with envelope, from the above analysis it is obvious that the effective radius of a given drain with a well-specified envelope is independent of whatever definition is used for the entrance resistance.

Corrugated plastic drain pipes with a perforation in each corrugation and wrapped with a thin envelope ‘sheet’ which spans the corrugations and keep them free from soil makes the drain surface much more permeable and reduces the entrance resistance considerably (Willardson and Walker, 1979; Salem and Willardson, 1992). A substantial reduction of the entrance resistance is obtained if an envelope is installed which has a hydraulic conductivity at least 10 times higher than that of the surrounding soil. The thickness of the envelope should, preferably, be at least 5 mm (Nieuwenhuis and Wesseling, 1979; Dierickx, 1980). More favourable specifications do not significantly decrease the entrance resistance any further. Still, greater envelope thickness enhances the effective radius, because the soil around the drain is replaced by a comparatively more permeable envelope.

The effective radius of a wrapped drain increases, if the hydraulic conductivity and/or the thickness of the envelope are made larger. The use of a sufficiently permeable envelope ( $\kappa_e \geq 10$ ) which is adequately thick ( $d_e \geq 5$  mm) around a plain drain reduces the entrance resistance drastically. If  $\kappa_e \geq 10$  and  $d_e \geq 5$  mm, drains wrapped with envelopes which have the same external radius,  $r_e$ , have almost the same effective radius,  $r_{ef}$ , regardless the pipe radius,  $r_o$ , and the envelope thickness,  $d_e$  (Figure 32). Thus, it may be more cost efficient to select the minimum drain diameter required to satisfy the discharge capacity, and to wrap with a relatively thick envelope, than selecting a greater diameter pipe, wrapped with a relatively thin envelope. This is because larger diameter pipes are much more expensive than a larger amount of envelope material, required to arrive at the same external diameter  $r_e$ .

### Drain with a less permeable surround

It is generally accepted that drainage works must be carried out under circumstances that do not challenge the structural stability of a soil. The moisture content of the soil is a critical factor because drainage works carried out with trenchers in wet conditions may result in deterioration of the structure of the excavated soil. As a result, the drain surround becomes less permeable than that of the surrounding natural soil. Trenchless and mole drainage techniques can locally

compact the soil around the drain or mole channel, inducing a less permeable zone around it. Invasion of soil particles into the envelope and/or chemical deposits can result in a partial blocking of the pores and a decreased hydraulic conductivity of the external envelope surface.

Experimental research shows that, if an envelope has a substantial thickness, e.g. >5 mm, and if its hydraulic conductivity is less than 10 percent of that of the surrounding soil, the entrance resistance may be very large, and consequently the effective radius of the drain reduces to extremely small values. This is mainly due to impeded flow in the less permeable layer surrounding the drain. If the drain is wrapped with an envelope, smearing and compaction of the surrounding soil influences the entrance resistance less than envelope clogging, yet the effective radius may be reduced to intolerable values.

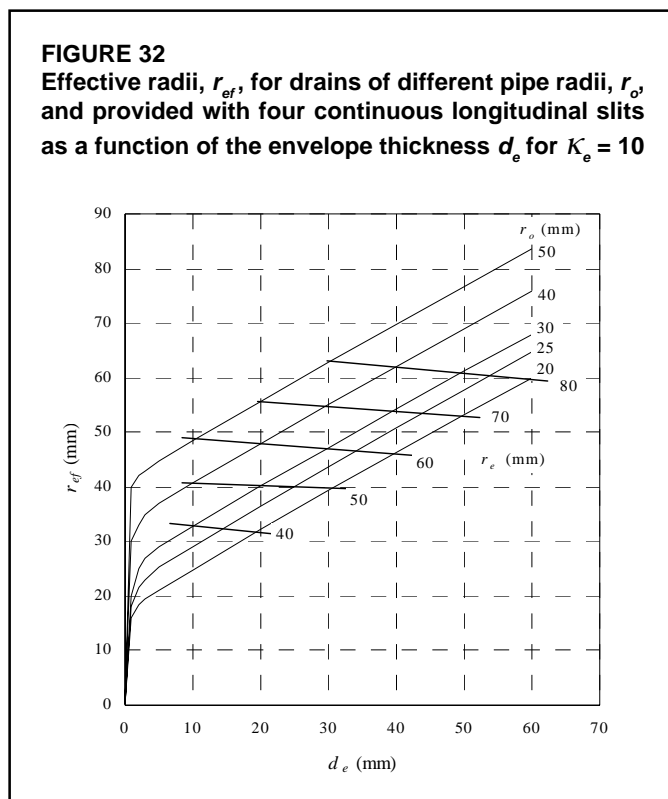

A less permeable layer surrounding either a plain drain or a drain with a more permeable envelope has an adverse influence on the performance of drain materials and must therefore be avoided at all times.

Mutual differences between the entrance resistances of various types of drainpipes may be important if these drains are installed without envelope. The hydraulic characteristics of the abutting media (either the soil or the envelope and the soil) are, however, much more relevant than the specifications of these pipes.

#### DISCHARGE CAPACITY OF DRAINPIPES

The discharge capacity of drainpipes is an important component of any design procedure for land drainage systems, and is described in all major drainage textbooks. The available information ranges from exhaustive (Cavelaars *et al.*, 1994) to straightforward treatment, which is limited to the fundamentals only and some useful examples (Smedema and Rycroft, 1983). In this guide, only the most relevant material is discussed, following Dierickx (1993). Readers who want to be informed further on the subject are referred to the above publications. Additional information on design procedures (i.e. formulae) in various countries is given in Framji *et al.* (1987). Pipe diameter nomographs, which are quite useful for a 'quick scan' analysis of the required pipe diameter(s), are given in Smedema and Rycroft (1983). A computer program for calculating the diameter of drainpipes is in preparation by FAO.

It is often financially attractive to increase the pipe diameter of collector drains and even of lateral drains in the flow direction. In doing so, the diameter is adjusted for the discharge, which increases in the direction of the outlet. This issue is discussed in depth by Cavelaars (1979), and illustrated in a simple case by Smedema and Rycroft (1983). The forthcoming FAO-publication on drainage design also includes the design of such composite drains.

The hydraulic design of drainpipes is based on formulae that relate the discharge of water to the pipe diameter, the hydraulic roughness of the pipe wall and the hydraulic gradient. Different formulae are used for smooth and corrugated pipes.

Clay, concrete and smooth plastic pipes are considered hydraulically smooth pipes. Their discharge capacities can be calculated from the Darcy-Weisbach equation. The discharge capacity of corrugated pipes can be calculated from the Chézy-Manning equation. For laterals, a minimum pipe diameter is advisable to compensate for less accurate grade and alignment, and eventually for some settlement that may occur, thus assuring the discharge capacity of the drainage system. In European countries, a minimum diameter of 50 or 60 mm is accepted; elsewhere the minimum diameter is 80 mm and in the United States the smallest diameter is 100 mm. For collector drains the length covered by a given pipe diameter for a specified hydraulic gradient is calculated.

In the Chézy-Manning equation, the hydraulic roughness (or 'friction resistance') of the pipe wall is expressed as Manning's coefficient,  $n$ , or its reciprocal parameter,  $k_M$ . For drainpipes with diameters ranging from 50 to 200 mm and small corrugations, the roughness coefficient  $n = 0.0143 \text{ s m}^{-1/3}$  (or the reciprocal value  $k_M = 70 \text{ m}^{1/3} \text{ s}^{-1}$ ). From the results of Irwin (1982, 1984), Boumans (1988) established that the  $k_M$ -value of larger diameter pipes with large corrugations can be expressed as:

$$k_M = 18.7d^{0.21}S^{-0.38} \quad (35)$$

in which  $d$  (m) and  $S$  (m) are the internal pipe diameter and the pitch length, respectively. For most pipes with large corrugations, a roughness coefficient  $n = 0.02 \text{ s m}^{-1/3}$  (or  $k_M = 50 \text{ m}^{1/3} \text{ s}^{-1}$ ) can be accepted.

The type of pipe and the hydraulic gradient determine the discharge capacity of drainpipes. The calculation of the discharge capacity of drainpipes may be based upon two principles (Wesseling and Homma, 1967; Wesseling, 1987):

- the *transport principle with uniform flow*, whereby a drainpipe is assumed to transport a fixed discharge along its length, while the pipe itself is flowing full; and
- the *drainage principle with non-uniform flow*, whereby a constant inflow of groundwater into the drain along its length results in a discharge which increases along the length of the pipe.

Application of both principles and pipe characteristics yields the following set of equations:

Transport principle

Drainage principle

Clay, concrete and smooth plastic pipes

$$Q = 50 d^{2.714} s^{0.572} \quad (36)$$

$$Q = 89 d^{2.714} s^{0.572} \quad (37)$$

Corrugated pipes with small corrugations (usually pipes ranging from 50 to 200 mm in diameter)

$$Q = 22 d^{2.667} s^{0.5} \quad (38)$$

$$Q = 38 d^{2.667} s^{0.5} \quad (39)$$

Corrugated pipes with large corrugations (usually pipes with a diameter beyond 200 mm)

$$Q = 15 d^{2.667} s^{0.5} \quad (40)$$

$$Q = 27 d^{2.667} s^{0.5} \quad (41)$$

with  $Q$  = discharge ( $\text{m}^3 \text{s}^{-1}$ );  
 $d$  = internal diameter (m); and  
 $s$  = hydraulic gradient (dimensionless).

All equations are derived for clean pipes. Comparison of these equations reveals that the assumption of the *transport principle* for the determination of the diameter of drainpipes implies that a safety factor is automatically incorporated in the design. The equations based upon the *drainage principle* yield larger discharge capacities, and, as such, larger surfaces that can be drained with a given pipe diameter. Adoption of some safety factor is indeed required to incorporate the risk of possible mineral and/of chemical clogging of the pipe in its hydraulic design. Usually, pipes are 'over designed' to allow for subsequent partial mineral or chemical clogging, and for misalignment during installation.

When applying the *drainage principle*, a safety factor must be imposed because this principle is based on a more realistic physical concept, which leads to a more economical yet risky design. For practical application, the discharge capacities as calculated with the formulae based upon the drainage principle are commonly reduced to 60 percent of the calculated values to include a safety factor for possible mineral and/of chemical clogging of the pipe (Cavelaars, 1974). This means that, in the end, both principles result in approximately the same discharge capacity (Dierickx, 1993). For collector pipes, the theoretical capacity is usually only reduced to 75 percent. Hence, an extra safety of 15 percent is built in when using the formulae based upon the transport principle.

Additional reduction factors up to 50 percent may still be advisable to compensate for pipe clogging, misalignment and an erroneous assessment of the pipe roughness coefficient (El Atfy *et al.*, 1990). The reduction factor may be conservative (25 percent) if corrugated plastics pipe is installed in stable soil, yet must be comparatively large (50 percent) for tile drains laid in unstable soil.

Too small a drain or a drain partially filled with sediment causes a reduced transport capacity. The pipe section will then be too small for discharging the groundwater properly, and the water in the drain will be flowing under pressure. Water may be standing above the drain and the groundwater table midway between drains will be too high. Too small a diameter or a reduction in transport capacity can be observed by a piezometer to measure the water head in the drain, and observation wells for the height of the water table transversal to and near the drain.

## Chapter 5

# The problem of clogging of pipes and envelopes

### MINERAL CLOGGING

#### Processes in soils around drains

A major problem that is often encountered on subsurface drains is mineral clogging of pipes and envelopes. This physical process occurs as the result of sudden drastic changes in soil-water conditions near the pipes caused by their installation. Immediately after installation, a new equilibrium begins to be established at the vulnerable area near the interface between the backfilled soil and the surface of the drainpipe or the surface of the envelope. The area is vulnerable because the physical strength and the structural stability of the soil has been weakened by the installation process. Moreover, groundwater starts flowing towards the drain, whereby the hydraulic gradients and the flux densities, being high in this area, induce substantial drag forces on the soil particles.

Soil movement at the interface between soil and envelope (or pipe wall) caused by flowing water is often referred to as internal soil erosion. Ziems (1969) made an extensive study of this phenomenon. He indicated that soil particle movement at the interface between two media may be, in fact, caused by three different physical phenomena, namely the washing out of fine soil particles (creating a '*natural filter*'), contact erosion and soil collapse. The physical process leading to the development of a natural filter in a soil has been discussed by various authors (Stuyt, 1982, 1992a; Cavelaars *et al.*, 1994). Another phenomenon, which adversely affects water entry into drains, is the development of a so-called '*filter cake*'.

The phenomena just mentioned may be characterized, in brief, as follows:

**Natural filter.** If only fine soil particles are washed out, a coarser soil skeleton is left behind that bridges over the openings in the drain or in the envelope. The formation of a natural filter, for instance in soil backfilled on top of a granular envelope, is illustrated in Figure 33. The drag force of the water that flows toward the drain causes small soil particles to move into and through the envelope while those of larger sizes are retained (Time 1). After some time, a highly permeable '*natural filter*' will develop in the soil adjacent to the envelope (Time 2), with an enhanced hydraulic conductivity. If coarser particles are washed out also, the formation of a natural filter in the soil may be superseded by excessive soil particle movement, which will locally undermine the physical strength of the soil skeleton. This process, in turn, promotes contact erosion.

**Contact erosion** means that particles of nearly all sizes are washed out locally, resulting in modification of the skeleton which transfers the effective stresses within the soil. The result of contact erosion is shown in Figure 34. Here, the drag force of the water that flows toward the drain causes soil particles of all sizes to move into and through the envelope (Time 1). After some time, macropores will develop at the interface between the envelope and the soil (Time 2).

**Filter cake.** A filter cake is a dense layer of soil particles which develops if suspended, fine soil particles accumulate at or near the interface between the soil and the envelope. The greater part of this area is often located in the soil rather than in the envelope (Stuyt, 1992a). Figure 35 shows the development of a filter cake in the course of which fine soil particles move toward but do not enter the envelope (Time 1). Many particles accumulate in the soil near the interface between the soil and the envelope (Time 2). This condition occurs when the envelope openings are too small and act as a filter for the small soil particles moving with the water. The hydraulic conductivity of filter cakes is often considerably smaller than that of the original soil, because fine soil particles clog the soil pores at the soil-envelope interface.

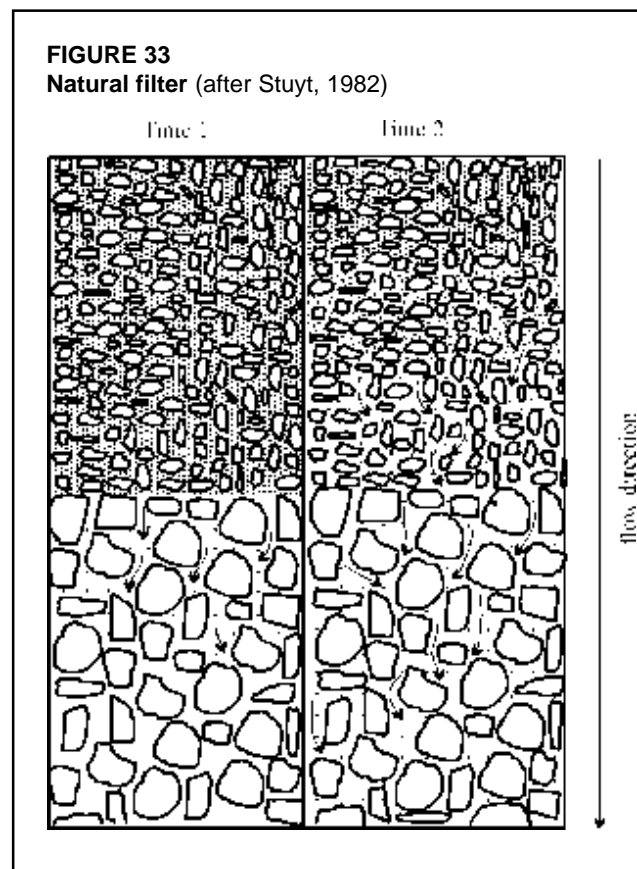

**Soil collapse.** When the drag force of the water surpasses the cohesive forces and intergranular stresses of a soil, the soil collapses and may consolidate. Soil collapse is illustrated in Figure 36. It shows that, after installation of the drain, the cohesion of the soil prevents soil material from moving toward and into the envelope (Time 1). At a later stage, soil aggregates are dislocated and soil particles move through the envelope towards the drain (Time 2). Some secondary bridging may occur at the soil-envelope interface that stops further soil movement into the envelope.

Soil collapse implies local soil structural failure, dispersion of soil aggregates and movement of soil particles of all sizes at the interface between the soil and the envelope. Soil collapse is most likely to occur in heavy, cohesive soils at high

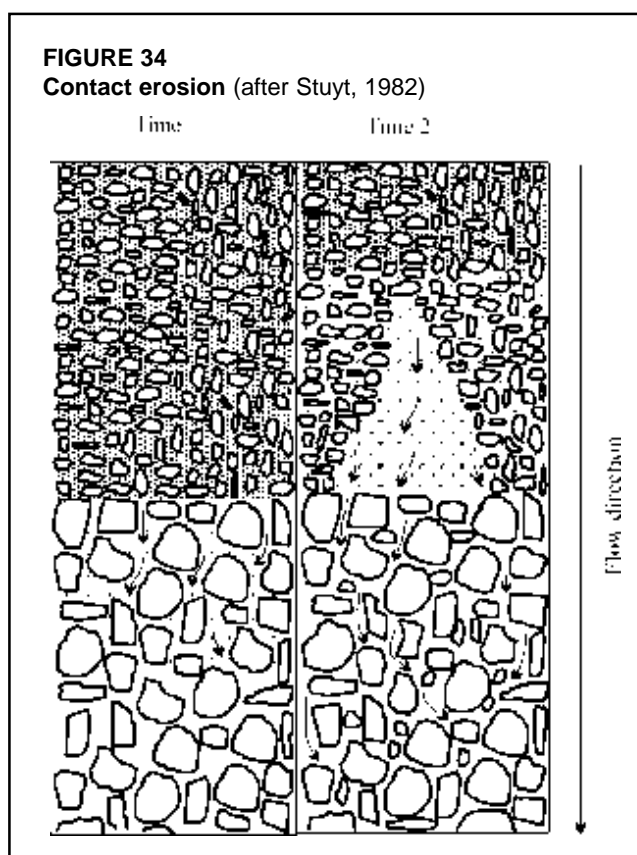



hydraulic gradients. The drag force of the water and the soil load, induced at drain depth, may even cause the saturated soil material near the drain to be pressed through the envelope and into the pipe perforations, as a muddy substance (Van der Louw, 1986; Stuyt, 1992a).

Until recently, *contact erosion* was considered harmful to the successful functioning of subsurface drains (Stuyt, 1982). Later observations however indicated that a low rate of contact erosion is favourable in that it promotes the formation of a macropore network around the drain. This network plays an important role in the conveyance of water into the drain.

Stuyt (1992a) made a serious attempt to gain insight into the *physical processes, associated with mineral clogging*. A CT scanner was used to obtain three-dimensional (3-D) digital images of soil cores, containing 300 mm long sections of wrapped drainpipes with the surrounding soils. After a service life of five years, 45 drain sections were retrieved from three experimental fields, located in areas in The Netherlands where the soils at drain depth consist of very fine sands: indeed problem soils with low structural stability. Each CT-sequence is a 3-D, geometrically precise mapping of the interior density variations inside drain envelopes and the surrounding soils. In the 3-D images, two major types of soil pores could be distinguished, namely *textural pores* inside soil aggregates and *macropores* (voids, cracks) which separate these aggregates. In 40 percent of all cases, the average macroporosity in the trench was lower than that in the subsoil. Two types of soil structural features were found in the subsoil: horizontal layering and vertically oriented macropores (Figure 37).

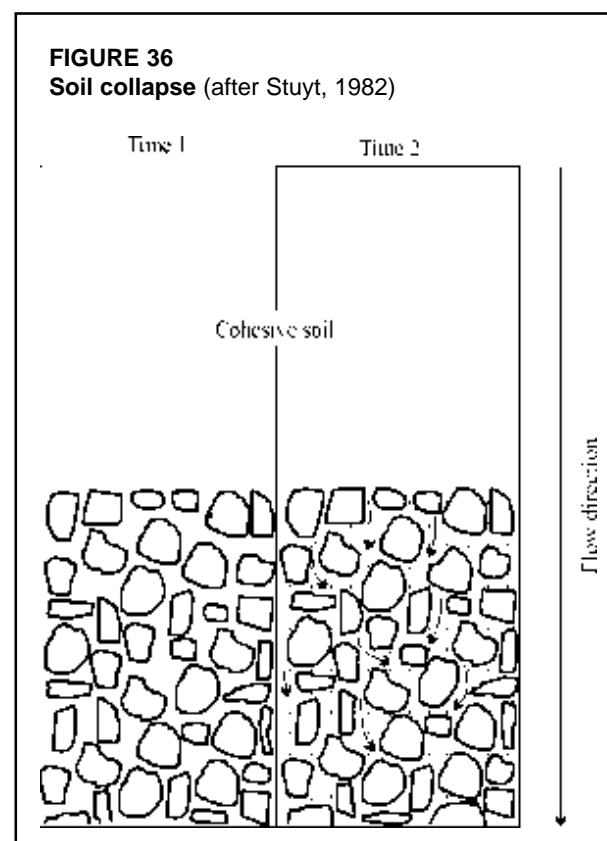
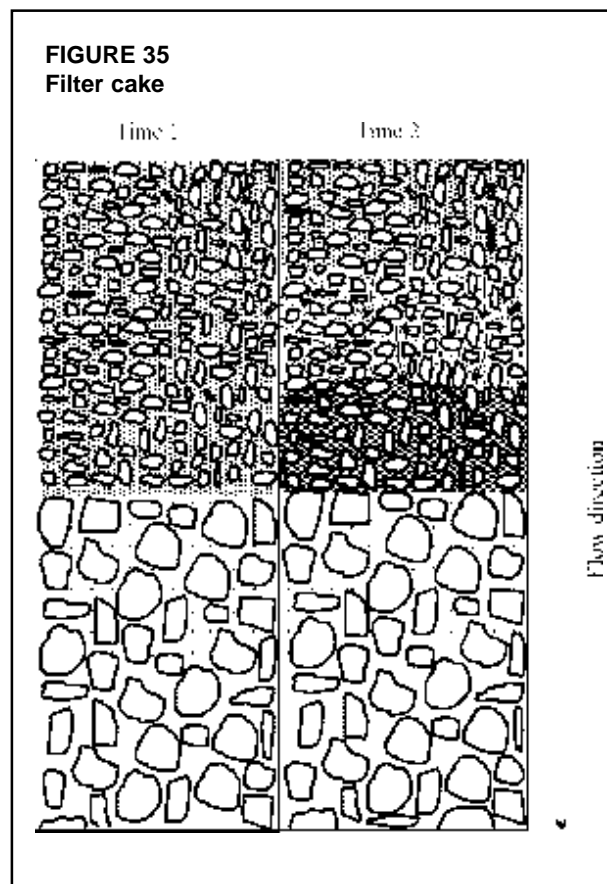

**FIGURE 37**  
 Example of a layered subsoil (left) and of a subsoil with vertically oriented macropores, that had developed at former root channels (right) (after Stuyt, 1992b)

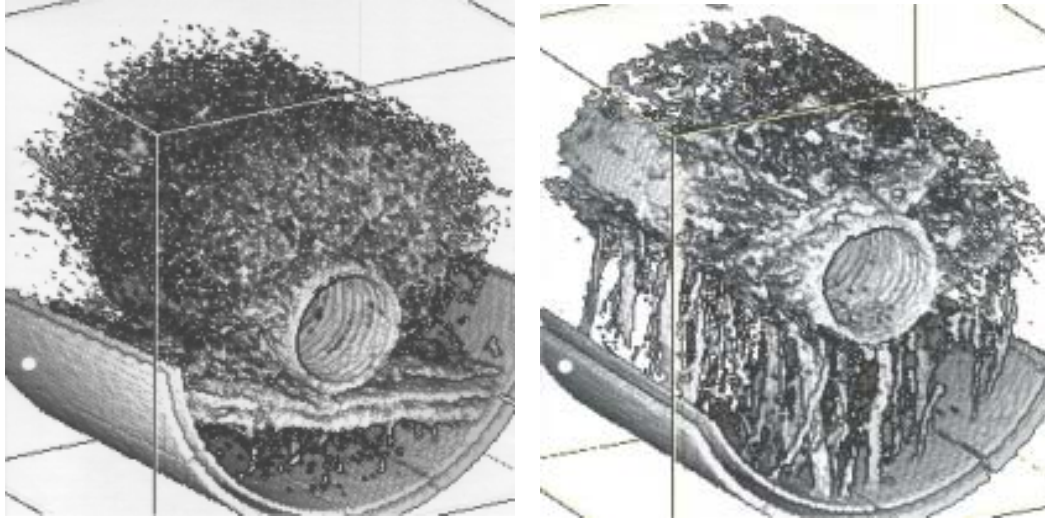

**FIGURE 38**  
 Image areas displaying drain envelopes and active macropores (after Stuyt, 1992b)

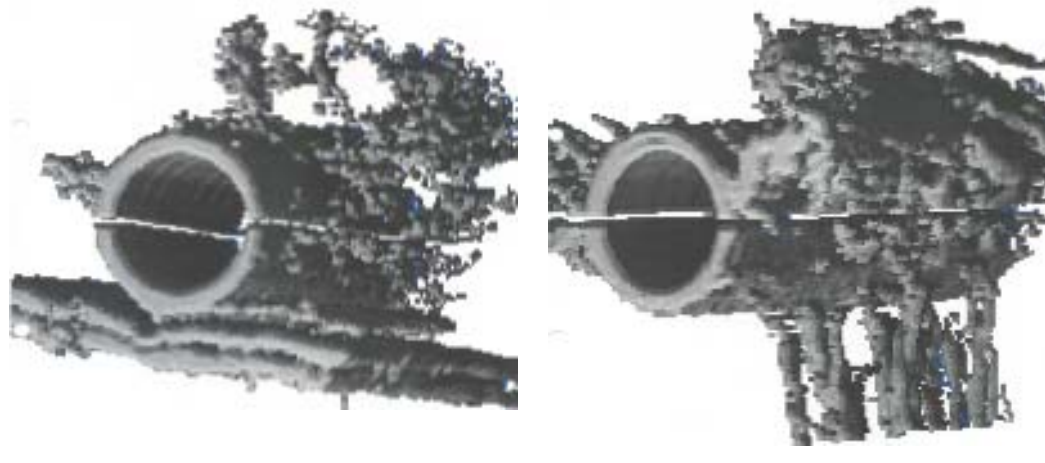

In Figure 37, only the relatively permeable areas in the soil around the drain are depicted. There is no relation between soil permeability and the intensity of the grey shading. The latter is induced by image processing techniques in order to facilitate visual interpretation of the highly complex image. Parts of the Plexiglas rims of both the sample container and the sample holder of the CT scanner were cut away by image processing techniques.

Not all the permeable areas depicted in Figure 37 are physically connected to the drain and, as such, conveying water into it. Using a 3-D image analysis technique, the areas that are connected to the drain - the so-called *active macropores* - could be detected. In Figure 38, these active macropores are displayed. The depicted samples in Figure 38 are the same as the ones displayed in Figure 37. It can be clearly observed that only a minority of all the detected permeable

areas is actively conveying water into the drain. These active macropores are partly developed through contact erosion processes that must have taken place during soil settlement after installation.

Subtle banding is evident underneath the drain, indicating comparatively permeable soil layers, and the drain trench contains some geometrically complex macropores (Figure 38 left). Water access to the drain on the right proceeds through a series of parallel, vertically oriented macropores.

The heterogeneity of mineral clogging of voluminous envelopes, as detected on field samples is illustrated in Figure 39 in the form of transformed CT-images that depict the envelopes as flat surfaces. Areas that are not seriously clogged are grey. Clogged envelope areas are not depicted and appear white.

**FIGURE 39**  
Illustration of the heterogeneity of mineral clogging patterns as detected inside voluminous envelopes (after Stuyt, 1992b)

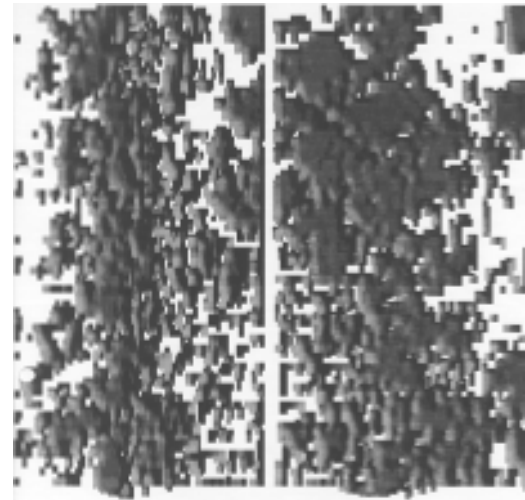

Contrary to theoretical assumptions, the effect of an envelope on the water flow pattern towards a drain is often limited, as is its effect on the radial and the entrance resistance. Study of all water flow patterns into the drains revealed that there is no evidence that envelope specifications have a significant effect on the geometry of such patterns. Variation of the flow resistance near a subsurface drain is therefore likely to be largely associated with structural features of the soil, i.e. its macroporosity and the geometric arrangement of the macropore network near the drain. The so-called effective opening size,  $O_{90}$ , appeared to be the only crucial design parameter for an envelope. Unlike any other envelope specification, the  $O_{90}$  value had a significant effect on the rate of mineral clogging of drainpipes (Stuyt, 1992a).

Envelopes largely act as soil ‘retainers’ or permeable constraints that physically support the soil near the drains. Given the importance of the physical properties of soils in relation to the process of mineral clogging, good installation practice will favourably affect the service life of wrapped drains. On the other hand, well-designed envelopes cannot cancel the unfavourable physical properties of the surrounding soils, nor can they compensate for poor installation practice. Installation under general wetness must therefore be avoided as much as possible.

### Pipe clogging

Sedimentation in drainpipes does not depend only on the intrinsic characteristics of the soil. Other factors such as the conditions and the quality of installation and inadequate maintenance of the drains, e.g. high pressure jetting, can cause sedimentation in drains.

Mineral deposits in drains are due to soil grains passing the envelope (if any) and the openings in the pipes. Fine particles ( $< 20 \mu\text{m}$ ) are usually carried in suspension, causing a turbid outflow. Sand remains in place and - if abundant - will cause pipe clogging. In flat country, with drain gradients around 0.2 percent (0.2 m per 100 m) even very fine sand (median particle size 50

µm) will stay near the entry point in the pipe. Self-cleaning of the pipe may be expected only at much steeper gradients.

#### CHEMICAL AND BIOCHEMICAL CLOGGING

In subsurface drains, there are four known types of deposits that are associated with bacterial activity. These are ochre deposits, manganese deposits, sulphur slime and iron sulphide. Gelatinized, voluminous oxidized iron deposits, named ochre, are the most serious and widespread. Other known deposits are lime and gypsum, which mostly occur in subsurface drains of irrigated areas as a result of the chemical composition of the soil and the quality of the irrigation water.

#### Iron ochre

The gelatinous slimes, associated with ochre deposits are usually yellow, red, or tan in colour. Ochre is filamentous (from bacterial filaments), hydrated (more than 90 percent water), and its dry matter has a high iron content (2-65 percent dry weight). They usually contain an organic matrix (2-50 percent dry weight) (Ford, 1979, 1982a).

There are two main categories of ochre problems:

1. ***Ochre as a temporary problem, called autochthone (of local origin).*** Temporary ochre as a clogging factor may disappear over a period of three to five years. It usually occurs rapidly and can be often detected at drain outlets soon after drain installation. If the drains can be maintained in working order, the concentration of  $Fe^{2+}$  reaching them will gradually decrease.
2. ***Ochre as a permanent problem, called allochthone (of foreign origin).*** Permanent ochre is the most hazardous condition because it continues to be a clogging agent for the service life of the drainage system, regardless of treatment. Permanent ochre occurs in soils that contain extensive quantities of residual iron and natural energy. The soluble reduced iron originates from surrounding areas, hence the name, and is transported by seepage into the drained area. There are ochre locations where the soluble iron originates 4 to 6 km from a drainage site. Thus, it is important to consider topographical terrain features when estimating the potential for permanent ochre formation. In general, sites considered to have permanent ochre potential should not be tile-drained without modifications in design and provisions for continuous maintenance.

Ochre can be found in the soil abutting the drain envelope, the envelope itself, the pipe perforations and within the drain pipe. Most clogging in corrugated pipes can be traced to sealing of the perforations and accumulations within the valleys of the corrugations. Within the pipes, the heaviest accumulation of ochre appears to be in the lower third of the drain length, although the lower third is usually not the region of maximum ochre formation. Ochre can usually be detected at drain outlets or in manholes as a voluminous and gelatinous mass. However, it may be present in the drains, while not visible at the outlet.

#### *Ochre formation*

The development of ochre requires reduced or *ferrous* iron ( $Fe^{2+}$ ) flowing into drains as raw material. The minimum concentration of ferrous  $Fe^{2+}$ , necessary for growth of the iron bacterium *Leptothrix*, is 0.12 mg/l (0.12 ppm) (Ford, 1980).

It must be in solution in the groundwater rather than located on soil particles. It is present mostly as iron hydroxide ( $\text{Fe}(\text{OH})_2$ ) or as iron sulphide ( $\text{FeS}_2$ ), and will precipitate when oxidation takes place after contact with air, e.g. near and inside subsurface drains (Smedema and Rycroft, 1983). Many soils contain substantial quantities of iron, yet the conditions, required to create ochre problems in drains vary considerably.

Bacteria are required to convert the insoluble *ferric iron* ( $\text{Fe}^{3+}$ ), which is located on soil particles, to a soluble form ( $\text{Fe}^{2+}$ ) which can be transported to the drains by groundwater advection. *Ferrous iron* ( $\text{Fe}^{2+}$ ) can only exist in groundwater if the oxygen in the soil has been depleted, e.g. after a soil is flooded for a considerable time, or when micro-organisms have used all available oxygen. If this condition is met, iron-reducing bacteria reduce the insoluble ferric iron ( $\text{Fe}^{3+}$ ). This biological action of the bacteria is energy intensive, and energy sources must therefore be present. The major sources are organic material like remnants of plants and plant roots, and certain acids like malic, citric, tannic and lactic acids. Hence the higher the organic content in the soil, the faster and more widespread the conversion from  $\text{Fe}^{3+}$  to  $\text{Fe}^{2+}$  by bacteria will be.

Soluble  $\text{Fe}^{2+}$  flowing in groundwater enters a different environment as it approaches the drain and passes through the drain envelope. If some oxygen is present in this area, certain filamentous and rod-shaped bacteria will precipitate some of the  $\text{Fe}^{2+}$  as insoluble  $\text{Fe}^{3+}$  and incorporate it into ochre. Iron-precipitating bacteria must be present for extensive clogging to occur, even when other conditions are just right for chemical precipitation of the iron. *Iron alone does not have serious sticking properties*. The reaction inside drains is a combination of bacterial precipitation and the incorporation of chemically precipitated iron into the sticky slimes of the bacterial masses involved in the ochre matrix.

There is a type of ochre that forms only at low pH, in *pyritic* soils (acid sulphate soils). These soils are found in many coastal areas as well as in mine dumps and in certain shales. Pyrites are formed from iron and hydrogen sulphide in flooded marine deposits. When such soils are drained, the pyrites first oxidize to  $\text{Fe}^{2+}$  and sulphates. These sulphates change to sulphuric acid, which lowers the soil pH below 3.5. The rod-shaped bacterium *Thiobacillus ferrooxidans*, which can function only in an acid environment, then converts the soluble iron into ochre.

In Egypt, Iraq and Pakistan no serious ochre problems have been reported. The absence of ochre there is due to the generally alkaline soil environment. In alkaline soils, ferrous iron ( $\text{Fe}^{2+}$ ) cannot exist in solution in the groundwater. In Israel, severe ochre problems have been encountered when draining certain swampy areas. The drainage systems were designed such that anaerobic conditions were maintained by placing an elbow at the drain outlets to create submergence. These systems have operated successfully for several years (Henkin, 1987). The same procedure was introduced in The Netherlands in the 1960s, yet with limited success (Huinink, 1991).

### ***Prediction of ochre problems***

The following on-site observations may give clues to potential ochre problems inside drains (Ford, 1979):

1. Soil types that appear to show the highest potential for ochre formation are fine and silty sands, organic soils, soils with organic pans and mineral soil profiles with mixed organic matter.

2. Sites being utilized for sprinkling of sewage effluent usually furnish sufficient energy for reduction reactions. Such sprinkled soils are potentially serious for ochre hazard if the profiles are subjected to long term flooding.
3. Some topographical features indicate possible ochre problems. If there is land of higher elevation close to the proposed drainage site, permanent ochre potential may be a problem due to permanent seepage. Valleys at the base of escarpments are typical for permanent ochre.
4. Flood plains of rivers and gullies are suspect, particularly if the site is a mixture of sand and organic matter.
5. Depressions containing organic residues are ochre prone sites.
6. Blue-coloured clays or bog-like, decomposable organic matter between 0.6 and 1.2 m below the soil surface suggest permanent ochre sites.
7. Oil-like films floating on surface water in canals may indicate ochre and may contain ochre forming bacterial filaments.
8. Gelatinous ochre that has precipitated on ditch banks and/or canal bottoms is an important indicator for potential ochre problems.
9. The amount of  $\text{Fe}^{2+}$  in groundwater is usually higher in soils with organic pans and a pH below six.
10. Based on practical experience, the least likely candidates for ochre problems are silty clays, clay loams and clay soils.
11. In arid areas, ochre is seldom a problem.

### ***Ochre potential ratings***

It is possible to estimate the maximum potential for ochre before installing drains, as well as to estimate whether specific soil types or profiles can be considered susceptible (Ford, 1982b). Analysing the *soils* for total iron is of no value because the values do not indicate soluble  $\text{Fe}^{2+}$  or the complex interactions between the soil pH and the soil type. The  $\text{Fe}^{2+}$ -content of the *groundwater* flowing into a drain is a reliable indicator of the potential for ochre clogging. The simplest way to determine the ferrous ( $\text{Fe}^{2+}$ ) iron content of the groundwater is using paper indicator strips, which are immersed in a groundwater sample. The colour can be used to assess the concentration of the ferrous iron. The concentrations are colour-coded into the following classes: 2, 5, 10, 25, 50, and 100 mg  $\text{Fe}^{2+}/\text{l}$ .

Ford (1982a) developed a reliable yet elaborate testing procedure to assess the ochre clogging potential of soil profiles before installing drains. This procedure is independent of pH and soil type. The method has been developed and tested extensively at numerous locations in the United States (Ford, 1982a). Using this method, it is possible to determine whether a soil layer may release much or little ferrous ( $\text{Fe}^{2+}$ ) iron, once water saturated, and whether the ferric iron ( $\text{Fe}^{3+}$ ), which is adhered to the soil particles, can be easily reduced to soluble  $\text{Fe}^{2+}$ .

Scholten and Ven (1987) have compared the ochre potential ratings, assessed with the Ford method, with the method using indicator strips. They found a strong correlation of the detected ferrous iron content, determined with both methods. However, the content indicated by the strips is consistently higher than the content indicated by the Ford method (ratio 3 to 4). Yet, for routine measurements, the simple method with indicator strips will suffice. In spite of the insufficient number of readings in their investigations, Scholten and Ven (1987) present a table (Table 8) to assess the ochre potential. The figures in this table are in reasonable agreement with the figures, proposed by Ford (1982a).

### ***How to minimize ochre clogging of drains***

There is no known economical, long-term method for effectively controlling ochre clogging in drains. Although options are limited, the emphasis must be on 'living with the problem.' The following recommendations may be useful (Ford, 1982a, 1982b).

**TABLE 8**  
**Ochre potential according to the Ford-method and the method of indicator strips**

Ochre potential	Ferrous ( $\text{Fe}^{2+}$ ) in groundwater (mg/l)	
	Ford method	Indicator strips
Very high	>10	>25
High	5-10	10-25
Moderate	2-5	5-10
Little	0.5-2	1-5
Negligible	<0.5	<1

1. *Precipitating iron in the soil by promoting oxidation.* Iron cannot be dissolved in groundwater until it is reduced. Hence, all measures that minimize the development of anaerobic conditions are acceptable. Soil aeration prevents reduction. Closer spacing and shallower depth of drains may be beneficial for certain sites.
2. *Size of the perforations in drainpipes.* The larger the pipe perforations, the longer the period before drain discharge may be severely restricted. Ochre adheres to frayed plastic edges of perforations. Cleanly cut inlet perforations are essential. Small perforations limit the effectiveness of jet cleaning as a method for cleaning drains installed with synthetic envelopes.
3. *Drain envelopes.* A graded gravel envelope is best. It may however still clog under conditions of severe ochre potential. Soil compatible, coarse structured PLMs may also reduce the risk of clogging by ochre. Relatively thin synthetic envelopes like geotextiles present the greatest risk. Surveys of selected drainage sites show that ochre clogging of drains, wrapped with synthetic materials occurs first in the slots and valleys of pipe corrugations, and can be present in amounts sufficient to cause drain failure. These materials clog relatively easily by ochre deposits because the iron precipitating bacteria easily grow across the voids in the fabrics. Of all thin synthetic envelopes, knitted polyester envelopes are the least vulnerable to ochre clogging.
4. *Organic envelope materials.* Envelopes, manufactured from pine, oak and cypress sawdust delayed ochre development at drain inlet openings for extended periods in Florida (United States). Sawdust creates an anaerobic environment and appears to be toxic to ochre enhancing bacteria. Sawdust may contain aromatic hydroxyl compounds that complexes iron. The use of peat and other organic envelope materials should be avoided. They usually increase ochre problems and enhance clogging.
5. *Submerged outlets.* Submerged drains in groundwater with high ochre risk prevent the soluble ferrous iron ( $\text{Fe}^{2+}$ ) to oxidize to the insoluble clogging ferric iron components ( $\text{Fe}^{3+}$ ) (Rozendaal and Scholten, 1980). This is an old recommendation that has been used with some success when the entire drain is permanently under water. The drain line must be completely under water over its entire length throughout the year. This may require that the drains be installed on a flat grade or horizontal.

### ***Ochre removal from drains***

Data on jetting of drains, wrapped with synthetic envelopes, are scarce. In The Netherlands, medium pressure jetting of ochre clogged drains has generally not been very successful. The dewatering capacity of jetted drains was not significantly enhanced, or only for a very short period. Jetting water must pass through the pipe perforations and be deflected by the envelope in order to clean the valleys. In structurally unstable soils, the pressure at the nozzle should not

exceed 20 bar, otherwise the soil near the drains may destabilize and flow into the drain (see Chapter 7, Section *Maintenance of drainpipes*). The larger the pipe perforations, the better the potential for cleaning the valleys and envelope. Jet cleaning is unsatisfactory if delayed until the ochre has aged and become crystalline and/or sticky. 'Dry' rodding (with a scratcher at the end without extra water) can also be applied successfully, provided that:

- the operation is carried out when the ochre is still slimy, before it had the opportunity to harden during a prolonged dry period (summer); and
- rodding is done while the drain is carrying water (wet period). Thus the (still slimy) ochre is easily loosened and will be carried away by the drain discharge (Cavelaars, personal communication).

As ochre clogging is usually most severe shortly after installation, it is recommended to jet the drains during the first year if ochre problems are suspected, rather than wait until the drains are clogged. Drains should discharge into open ditches rather than through closed collector systems. The access of single drains through open outlets greatly facilitates jetting. Herringbone or similar drain designs should have entry ports for jet flushing.

### **Lime and gypsum depositions**

Whereas ochre is a prominent problem in humid temperate regions, which has been investigated extensively on a large scale for many decades, the deposition of slightly soluble salts, such as calcium carbonate ( $\text{CaCO}_3$ ) and calcium sulphate as gypsum ( $\text{CaSO}_4 \cdot 2\text{H}_2\text{O}$ ), within drainpipes and envelopes is a not systematically investigated problem. There is ample scope for systematic investigation on lime and gypsum depositions with pipe drains; this would include an inventory of the extent of the problem and the conditions under which it is likely to develop. Lime and gypsum deposition is most likely a chemical process. The hard and crystalline deposits are likely to build up comparatively slowly so that adverse effects only appear after a long time.

The problem may occur in gypsiferous soils and soils with a high content of calcium carbonate, which are common in arid and semi-arid areas, or result from the salts applied with the irrigation water. Depending on the dissolved  $\text{Ca}^{2+}$ -content of the groundwater, it may however also occur in non-irrigated areas like Belgium where  $\text{CaCO}_3$  is reported to have cemented the gravel around a drainpipe of a road drainage system to a compact, impervious mass. Calcareous deposits in and around drains installed in soils that convey groundwater rich in dissolved  $\text{Ca}^{2+}$  also are reported in France (CEMAGREF, 1983). In arid regions, Cavelaars *et al.* (1994) found gypsum in excavated drains. No deposition of lime was however found in horizontal drainage systems, in spite of the lime deposition hazard - '*incrustation*' - of tube wells.

Precipitation of lime and gypsum may take place if the concentration of calcium compounds (carbonates, bicarbonates or sulphates) exceeds their solubility. Many waters, particularly in arid regions, are partly or nearly saturated with calcium bicarbonate, ( $\text{Ca}(\text{HCO}_3)_2$ ), which, upon concentration, precipitates in the soil as  $\text{CaCO}_3$ . Precipitation of  $\text{CaCO}_3$  and of  $\text{CaSO}_4$  will occur if the soil solution is concentrated by water removal during plant growth, and the solubility of the relatively insoluble  $\text{CaCO}_3$  and the more soluble  $\text{CaSO}_4$  is exceeded.

This physical process does not explain the precipitation of  $\text{CaCO}_3$  in the drain envelope and at the perforations which may result from the conversion of  $\text{Ca}(\text{HCO}_3)_2$  through the loss of carbon dioxide, ( $\text{CO}_2$ ). For tube wells, the precipitation hazard may be explained by the pressure decline in the groundwater at the entrance of the envelope or the tube openings.

Complete prevention of the deposition of  $\text{CaCO}_3$  and  $\text{CaSO}_4$  in a horizontal drainage system will not be possible, yet some measures can be taken to reduce the precipitation hazard of these



calcium salts. Keeping drainage systems under water will reduce the risk of more concentrated solutes near the drainage system and the release of CO<sub>2</sub> from the groundwater.

### **Manganese deposits**

Manganese, if dissolved in groundwater under suitable reducing conditions, can form a bacterially enhanced, gelatinous black clogging deposit.

### **Sulphur precipitate**

Sulphur slime is a yellow to white stringy deposit formed by the oxidation of hydrogen sulphide that may be present due to reduction of sulphates dissolved in groundwater. Sulphur bacteria oxidize the H<sub>2</sub>S to H<sub>2</sub>O and elemental sulphur S. Globules of elemental sulphur and masses of whitish, sticky slime are deposited within the filaments of these bacteria and forms a precipitate of sulphur at the drain outlets (Martínez Beltrán, 1978; Ford, 1980).

Sulphur slime has not been a serious problem in most agricultural drains. It is found most often in muck soils. It may also be present at sites designed for subirrigation through drainpipes if the well water used for irrigation contains hydrogen sulphide (H<sub>2</sub>S).

### **Iron sulphide**

Iron sulphide (FeS<sub>2</sub>) may be found under chemically reduced conditions, e.g. when drains are buried in mixed soil profiles, in gullies and river plains, or when topsoil or organic debris are used to cover the drains during installation. It is a gelatinous black precipitate formed by the reaction between ferrous iron (Fe<sup>2+</sup>) and hydrogen sulphide (H<sub>2</sub>S). It will usually not stick to light sandy soil particles. It becomes a clogging agent if it is present in amounts that can block soil pores. In general, iron sulphide should not be a serious problem for most installations that do not blind the drains with topsoil or debris of organic matter.

## **PENETRATION OF ROOTS INTO DRAINPIPES**

Field data concerning *root penetration* are scarce. Penetration of roots of field crops is rare in arable lands. Such roots may temporarily obstruct drain discharge and slightly enhance pipe siltation, but they will die after harvesting. Roots are more challenging in drains installed under perennial plants like trees and shrubs, e.g. under shelterbelts, which border orchards. They may fill the entire drain over a considerable length, trapping suspended materials and seriously obstructing drain discharge. Installing unperforated pipe sections at locations where such roots occur may prevent the problem (see Chapter 2, Section *Rigid pipes*).

In arid countries, drains are installed at 1.5 to 2 m depths and occasionally deeper, hence, root growth into the drains is less likely as compared with drains that are installed at shallow depths.

Quantitative information on root growth inside drains is scarce.

- In *Belgium*, during a dry spell, deep rooting cabbage caused problems in a shallow drainage system that was used to control a perched water table.
- In *Egypt*, the Eucalyptus tree is known to cause trouble (Cavelaars *et al.*, 1994).
- In *Israel*, the roots of certain types of Tamarix trees tend to clog drains. The roots of Tamarix and of some other types of trees cannot be removed, especially when gravel envelopes have been used (Henkin, 1987).

- In *Pakistan*, all trees located within a distance of 35 m from the drains were removed as a way of precaution in the Mardan Scarp project.
- In *Spain*, very fine roots of saline shrubs (*Suaeda fruticosa*) which grow on the banks of collector ditches were found to grow into laterals, causing serious clogging. This problem may be solved by installing unperforated pipe sections with a minimum length of 3 m at the downstream end where the laterals discharge in these ditches (Martínez Beltrán, 1987).
- In *Surinam*, an Asiatic vine called kudzu caused substantial problems of root growth inside drains (Van der Molen, 1972).
- In *Peru*, sugar cane was reported to grow into pipes at a depth of 1.5 m (Cavelaars, 1987).
- In *The Netherlands*, the occurrence of roots in agricultural lands is linked to the type of crop, the type of envelope, and the site that is drained. Roots penetrated easily into drains wrapped with organic envelopes (a mixture of peat and coconut fibres), glass fibre sheet envelopes, knitted sock envelopes, and a PLM envelope consisting of polystyrene granules. Thin synthetic envelopes however provided good protection. Root penetration was generally lower when the envelope thickness was greater (Stuyt, 1992a). Fruit trees (apples, pears) do not cause many problems, yet poplar (*Populus canadensis*) is known to be harmful.

## Chapter 6

# Guidelines to predict whether an envelope is required

Due to the drag force of water flowing toward a drain, soil particles may be carried into the drain from all sides. Drainpipe siltation may be due to particle invasion of cohesionless soil, to soil dispersion of cohesive soil at drain level, or to downward transport of dispersed or suspended material through soil pores, cracks and voids. This process can never be prevented completely, but it can be counteracted by installing an envelope material around the drainpipe. The need of envelope materials around drainpipes will depend on the physical and chemical properties of the soil, on the chemical composition of the water to be drained and on the conditions under which the pipes are installed. However, whether or not a soil presents problems is not easy to tell, because it cannot easily be derived from soil properties and conditions. Soil heterogeneity and the complicated nature of the physical interactions between water and soil near drain openings make prediction of the need for drain envelope materials very difficult.

Attempts have been made to define and identify soils that are prone to cause mineral clogging of drainpipes. Although many soil types have been identified as being more susceptible to sedimentation than others, sound criteria as to whether drains require an envelope or not have not yet been established. With the current state of knowledge, it is virtually impossible to determine universal criteria and fixed parameters to predict the tendency of mineral drain clogging for a given soil and the associated need of an envelope. Nevertheless, the experience gained during four decades of investigations and practice allows for a number of conclusions to be drawn. These are existing criteria, usually based on local experience and only valid for the regions where they have been established. They may therefore not be directly transferred to other regions without verification of their applicability.

Permeameter experiments with soil samples taken at design drain depth may provide information on the need of drain envelopes, by giving evidence of the structural stability of a soil and the risk of soil particle invasion into drainpipes. Permeameter research has been performed in the United States (Willardson and Walker, 1979; Samani and Willardson, 1981), the Netherlands (Stuyt, 1992a), Belgium (Dierickx and Yüncüoğlu, 1982), France (Lennoz-Gratin and Zaïdi, 1987) and is currently being conducted in Egypt, Pakistan, and India. Permeameter experiments on samples of soils and potentially suitable envelope materials are carried out with increasing hydraulic gradients. If the soil resists high gradients, a drain envelope is not required. An application is the assessment of the hydraulic failure gradient of a soil (e.g. Samani and Willardson, 1981). From comparison of permeameter results with those of field drains, Lennoz-Gratin *et al.* (1992) consider the permeameter flow test a reliable means to predict mineral clogging of drainpipes. The results of Stuyt (1992b), however, indicate that the association between laboratory data and field data may be quite ambiguous.

Apart from laboratory experiments, very simple field observations may give clues to the need to install envelopes in future drainage projects. Auger holes, intended for the determination of the hydraulic conductivity of the soil, may yield useful information in this respect. If such

holes collapse rapidly, so that a screen must be used, installation of an envelope is vital to protect future drains against mineral clogging. The occasional occurrence of soil layers or lenses of loose soil material at drain depth in a soil profile where drainpipes do not normally require an envelope may be a reason to wrap all drains with envelopes as a safety measure, in spite of the higher costs.

In the following sections the main soil properties related to the risk of soil particle invasion into drainpipes and the associated need to protect drainpipes against siltation are described. In addition, the influence of water quality on soil chemical composition has been considered. Finally, some prediction criteria for the need of drain envelopes have been defined.

## PHYSICAL PROPERTIES OF THE SOIL

### Soil texture

A soil consists of a skeleton of mineral particles with voids or pores, which contain air and water. Organic matter may be present as well, particularly in shallow soil layers. Mineral particles of soils vary widely in shape, size, mineralogical composition, and surface-chemical characteristics. The particle size distribution of a soil, often referred to as *soil texture*, is an important indicator for soil stability. It can be found by mechanical soil analysis. Soil particles

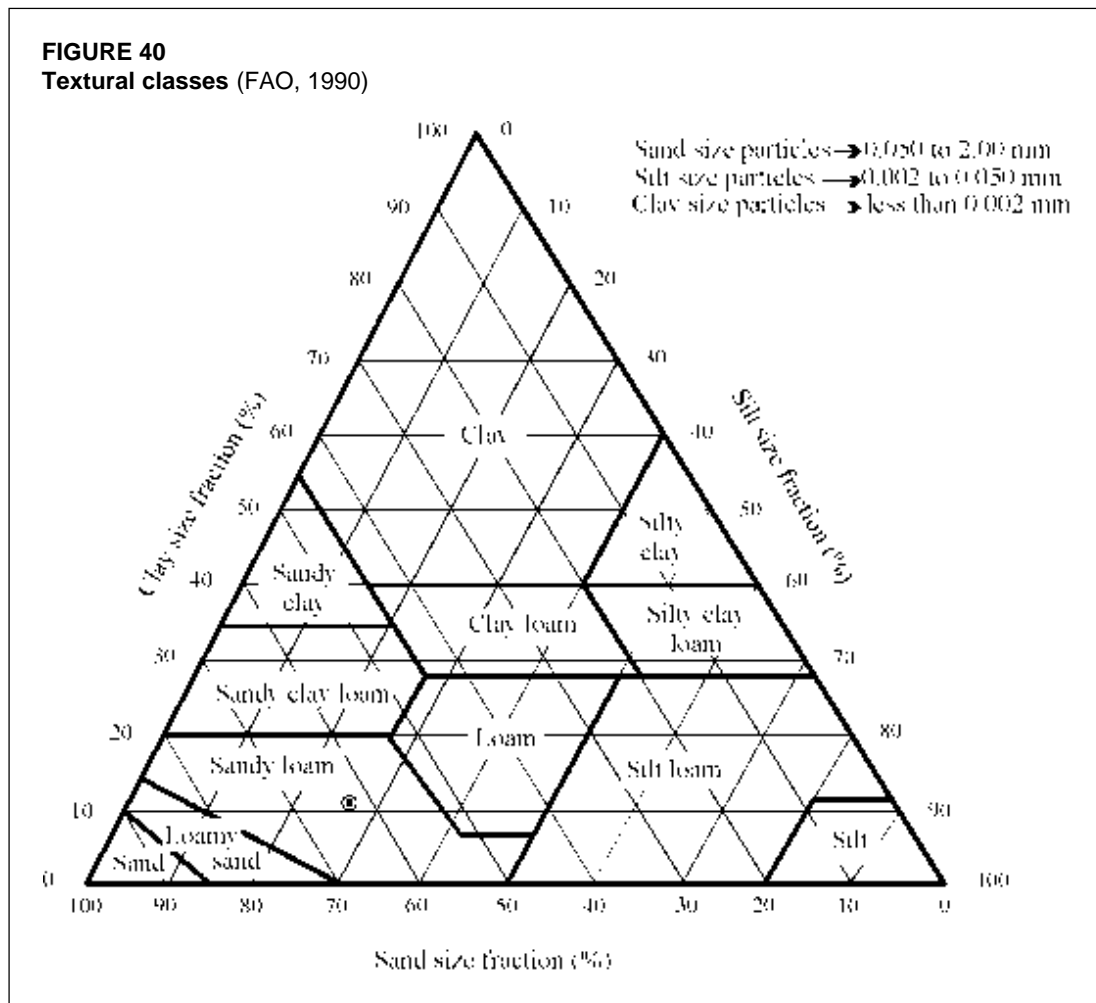

are normally classified as clay (< 2  $\mu\text{m}$ ), silt (2-50  $\mu\text{m}$ ) and sand (50-2000  $\mu\text{m}$ ). The dry weight percentages of sand, silt, and clay can be plotted in a triangular graph (Figure 40). Drawing these percentages on a line parallel to the base *opposite* to the indicated corner (which represents 100 percent sand, silt, or clay) the textural class can be found by the intersection of the three lines inside the triangle. Figure 40 shows that a soil with a clay fraction of 11 percent, a silt fraction of 27 percent and a sand fraction of 62 percent would be classified as sandy loam.

The cumulative particle size distribution curve (Figure 41) gives information on the cumulative percentage of soil particles (on dry weight basis) that is smaller than a given diameter. For example,  $d_{10}$  and  $d_{50}$  are the particle diameters for which respectively 10 and 50 percent of the soil particles (by dry weight) have a smaller diameter. A uniform soil has a 'steep' particle size distribution curve (curve 'a' of Figure 41), whereas a well-graded soil curve is less steep (curve 'b' of Figure 41). The latter has a  $d_{10}$  of 1.7 and a  $d_{50}$  of 105  $\mu\text{m}$ .

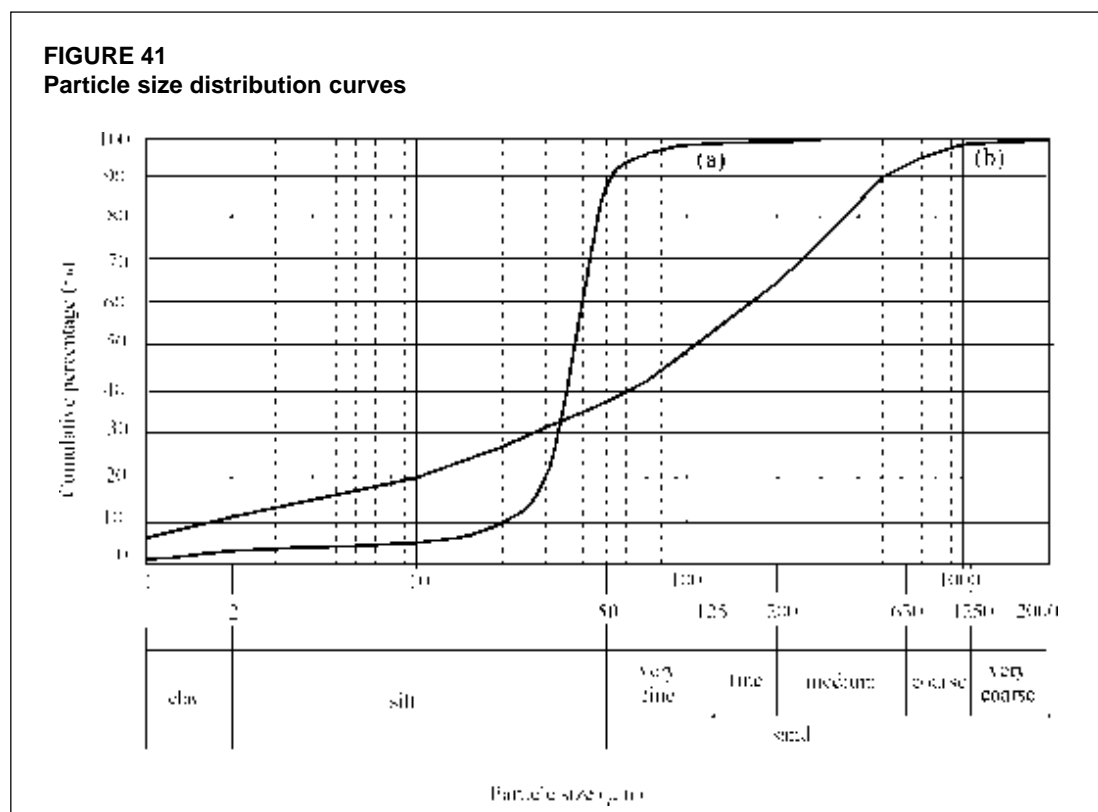

The coefficient of uniformity ( $C_u$ ) of a soil is a measure of the bandwidth of the sizes of the soil particles that it contains. This coefficient, which is reflected by the inclination or slope of its particle size distribution curve, is given by:

$$C_u = d_{60}/d_{10} \quad (42)$$

The greater the  $C_u$  value is, the less uniform or the better graded the soil will be. A uniform soil, with all particles of the same size, has  $C_u = 1$ .

Particle size distribution and soil texture classification can give a first indication of the need for a drain envelope. For loose soils like sands, the  $C_u$  coefficient is often employed to predict the need for drain envelopes. If the soil is cohesive, the clay percentage is a more significant indicator.

In various regions, criteria based on the clay content of a soil have been successful as a means of determining whether drain envelopes are required. In Quebec, drainpipes do not need envelopes in soils with a clay content of at least 20 percent (CPVQ, 1989) while in the Netherlands, the clay content should be at least 25 percent (Van Zeijts, 1992). In Egypt and in India, the clay content should be 30 percent or higher (Abdel-Dayem, 1987; Rajad Project Staff, 1995). Nevertheless, some of these soils still exhibited mineral clogging. This is caused by the fact that soil stability is not only depending on the physical, but also on the chemical composition of the soil (Section *Chemical properties of the soil*).

In fine cohesionless sandy soils, drains normally require an envelope. However, in Quebec (CPVQ, 1989) no envelope is recommended if the width of the perforations in the pipe wall is smaller than  $2 d_{85}$  (the particle diameter for which 85 percent of the soil particles by dry weight have a smaller diameter). Instead of 2, other values of this factor ranging from 0.5 to 10 have been accepted as well. Attempts to adapt the perforation width to a characteristic particle size diameter of the surrounding soil have failed because of the variability of both. Therefore, in cohesionless sandy soils, drain envelopes should be recommended under all circumstances.

Although texture alone is insufficient as a decision parameter for envelope application, it is generally accepted that soils with  $d_{50}$  between 50 and 150  $\mu\text{m}$  are mechanically quite unstable and, as such, sensitive to erosion (Dierickx and Leyman, 1991). They will therefore require an envelope.

Given the fact that soils with a great bandwidth of particle sizes do not present serious siltation problems, Olbertz and Press (1965) proposed the  $C_u$  coefficient as an *erosion likelihood* parameter:

- $1 < C_u < 5$  : very uniform and very sensitive to erosion.
- $5 \leq C_u \leq 15$  : moderately uniform and sensitive to erosion.
- $C_u > 15$  : no danger of erosion.

The ratio clay/silt percentage of a soil is also important. According to Dieleman and Trafford (FAO, 1976), the risk of mineral pipe clogging decreases rapidly when this ratio exceeds 0.5, where the particle size of silt ranges from 2 to 20  $\mu\text{m}$ .

In any case, soils with an important quantity of silt and a small amount of clay offer a great risk for mineral clogging of drains. A range of particle size distributions of such soils is presented in Figure 42. Any soil having a cumulative particle size distribution that lies completely or largely in the shaded area is likely to cause problems with drain clogging (Stuyt, 1982; Veldhuijzen van Zanten, 1986). The reason is that these soils have particles which are generally too big to be cohesive yet not big enough to be stopped from being washed into drain openings not protected by an envelope.

### Structural stability

In the Netherlands, field data indicate that soils may differ widely with regard to the rate of mineral clogging even though they have a comparable texture (Stuyt, 1992a). It has become obvious, over the years, that the structure of a soil is at least as important as its texture. However, it is rarely possible to interpret soil structure in terms of clogging risks, let alone clogging rates.

Soil structure refers to the way soil particles are bound together into natural, more or less porous compounds or aggregates. It is conditioned by the soil texture, the presence of organic

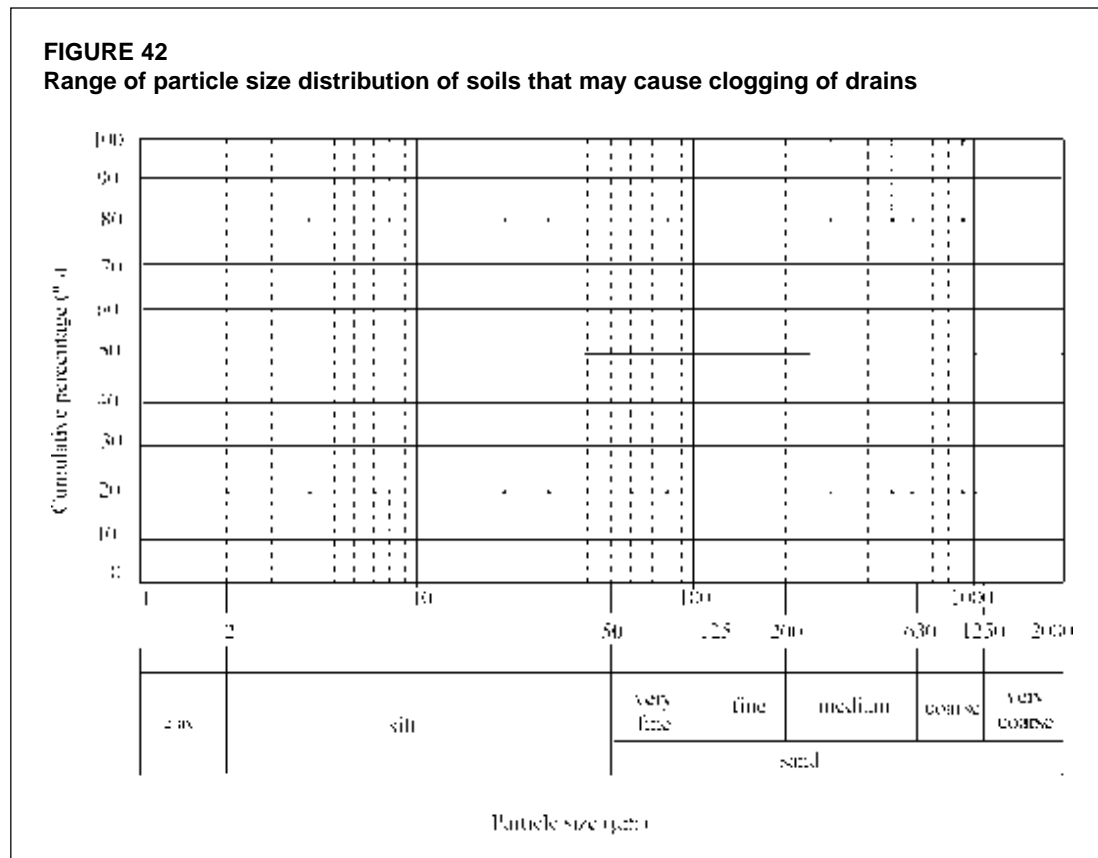

and other cementing substances, and the ratios between various cations that are present in the soil. Soil aggregates may be classified depending on the strength of the bonds between soil particles, which can range from loose, weak, moderate to strong bonds. Soil structure consisting of loose, individual soil particles is typically associated with sandy soils, yet the finer grained silts may also exhibit this type of structure. Such soils are structureless and have virtually no cohesion. Clay soils are generally cohesive and may be massive or develop blocky and prismatic structures. In some cases, however, they lose their cohesion and get dispersed (Section on *Chemical properties of the soil*). Soil structure governs, among other things, water flow toward drainpipes.

The firmness of the bonds between soil particles is called cohesion. Soil consistency refers to the behaviour of a soil at various moisture contents and largely depends on cohesion. Two well-known consistency limits are the *liquid limit* and the *plastic limit*, which form the so-called Atterberg limits. The difference between these two limits gives the plasticity index ( $I_p$ ). The  $I_p$  index is an indicator for the firmness of the bonds between soil particles.

The structural stability of soil aggregates is related to the attracting forces between the soil constituents, and determines the resistance of a soil to mechanical and physical-chemical destructive forces. To a certain extent, the structural stability of soil aggregates is determined by the amount of clay particles. Aggregate stability is an important soil characteristic when it comes to the assessment of the risk of mineral clogging of drainpipes, and it is known that drainpipes installed in stable structured soil do not require envelope materials. In spite of the availability of various methods to determine aggregate stability, e.g. by wet sieving, a straightforward, unambiguous procedure to classify the structural stability of soil aggregates

into significant figures is not available. The reason for that is that stability of aggregates is not an intrinsic property of the soil but depends on various conditions such as moisture content and chemical properties. Slaking of dry soil aggregates upon wetting is well known. However, if this soil remains in the plastic state at drain depth, it will largely resist slaking. Hence the structural stability of a soil is not a very reliable indicator when it comes to derive guidelines for the assessment of envelope requirement to prevent mineral clogging of drain lines.

The  $I_p$  index, mentioned above, is used to predict the sensitivity of a soil to mineral clogging of a drainpipe. Dieleman and Trafford (FAO, 1976) report the following:

- $I_p < 6$  : high tendency to siltation.
- $6 \leq I_p \leq 12$  : limited tendency to siltation.
- $I_p > 12$  : no tendency to siltation.

There are various modifications of this approach, sometimes in combination with other criteria (e.g. Lagacé, 1983).

### Moisture content

Under general wetness the structure of the soil is detrimentally affected when a subsurface drainage system is installed. Putting drains under wet conditions may destroy the structure of a soil almost completely and enhance the risk of mineral clogging of the pipes. Therefore, drains should not be installed under too wet conditions. Unfortunately, stopping the work during wet spells is often ignored for financial considerations. Moreover, drains must sometimes be installed at locations where the groundwater table is permanently above the envisaged drain level.

The warning not to install drains, if possible, during periods of excess wetness, or when the water table is quite shallow is not new. Cavelaars (1966) was one of the first to mention that the performance of a drain under field conditions is determined to a far greater extent by the actual condition of the soil around the drain, than by the type of drain or envelope material. His major conclusion was that installing drains under wet conditions could have a very harmful effect on the performance, especially in soils of low structural stability.

### CHEMICAL PROPERTIES OF THE SOIL

Structural stability of a soil is affected by its salt and sodium content. In addition, cementing agents in sands and silts are lime ( $\text{CaCO}_3$ ) and sesquioxides (Al- and Fe-oxides). Lime precipitates around the contact points between soil particles. The binding capacity of Fe-oxides is ill-defined, but Al-oxide is probably effective. Apart from these inorganic deposits, soil organisms and their organic by-products may also keep soil particles together.

The chemical composition of a soil is also quite relevant because of potential clogging of drainpipes and/or envelopes due to iron, lime and sulphate compounds (Chapter 5, Section on *Chemical and biochemical clogging*). Although drain envelopes cannot prevent chemical clogging, this phenomenon must be duly considered in any envelope selection procedure.

Assessment of the risk of mineral clogging of drainpipes as a result of the chemical composition of the soil requires knowledge of the cation exchange capacity, and the salinity and sodicity of the soil.

### Cation Exchange Capacity

Clay particles and humus have adsorptive properties. Clay particles are colloids that are so small that surface effects are dominant. Phenomena affected by soil colloids are dispersion,



swelling, shrinkage, flocculation, cohesion, and plasticity of soils. Clay particles have a negative charge and thus they adsorb positively charged cations such as  $\text{Na}^+$ ,  $\text{K}^+$ ,  $\text{H}^+$ ,  $\text{Ca}^{2+}$ , and  $\text{Mg}^{2+}$ .

Organic matter has a stabilizing influence on the physical and chemical properties of soils, despite its generally modest quantity. It promotes the development and the stability of soil structure. The finer components of organic matter are converted into humus, as a result of their decomposition by micro-organisms. Like clays, humus is also a colloidal material. Its capacity to hold ions exceeds that of clay but clay is generally present in larger amounts. Hence, the contribution of clay to the chemical soil properties usually exceeds that of humus, except in very sandy soils.

If soil colloids contain a high proportion of  $\text{Ca}^{2+}$  and other divalent ions, firm bonds are formed between mineral particles, leading to stable soil structure. In soils rich in  $\text{Na}^+$ -ions (*sodic soils*) the bonds are unstable, which results in a weak soil structure.

The total amount of cations that a soil can adsorb is determined by the negatively charged soil colloids clay and humus. This amount is called the *Cation Exchange Capacity (CEC)* of a soil and usually expressed in meq/100g of dry soil.

### Soil salinity

Soils may contain slightly soluble salts such as lime and gypsum and highly soluble salts such as sodium chloride and sodium sulphate. These salts may be contained in the soil parent material (primary salinization) or be transported dissolved in water and deposited after the soil has dried (secondary salinization). The major sources of secondary salinization are salts added with the irrigation water and through capillary rise of groundwater, mainly if the groundwater table is recharged by seepage. Salt contained in precipitation is negligible in comparison with the salt content of the irrigation water and the groundwater.

The anions predominantly present in salty soils are  $\text{Cl}^-$  and  $\text{SO}_4^{2-}$ , yet some  $\text{HCO}_3^-$  at *pH* values of 6-8 and  $\text{CO}_3^{2-}$  at *pH* values higher than 8.5 may be found.  $\text{Na}^+$ ,  $\text{Ca}^{2+}$  and  $\text{Mg}^{2+}$  are the predominant cations.

The total dissolved solids (*TDS*) can be assessed from measuring the electrical conductivity (*EC*). The *EC*-value and *TDS* are linearly related (Richards, 1954), and given by:

$$TDS = 640 EC \quad (43)$$

where *TDS* = total dissolved solids (mg/l); and  
*EC* = electrical conductivity (dS/m).

The electrical conductivity of the soil extract is usually determined in a soil paste saturated with water up to the liquid limit. This conductivity ( $EC_e$ ) is comparatively easy to measure. For most soils the *EC* of the soil solution at field capacity ( $EC_s$ ), some time after a rain or irrigation, is about twice the  $EC_e$ -value.

### Soil sodicity

The relative amount of adsorbed  $\text{Na}^+$ -ions, compared to the total amount of cations that a soil can adsorb is called the Exchangeable Sodium Percentage (*ESP*):

$$ESP (\%) = (Na^+_{ads}/CEC) \times 100 \quad (44)$$

where  $Na^+_{ads}$  is the quantity of adsorbed  $Na^+$ -ions (meq/100 g of dry soil). The *ESP* expresses the sodicity and hence the dispersion tendency of a soil.

Information on the chemical properties of the soil adsorption complex can be obtained from the soil solution since there is equilibrium between the adsorbed cations and the dissolved cations. Hence, another measure for the sodicity is the *Sodium Adsorption Ratio (SAR)*, derived from the concentration of sodium, calcium, and magnesium in the soil solution.

$$SAR = \frac{Na^+}{\sqrt{\frac{Ca^{++} + Mg^{++}}{2}}} \quad (45)$$

where the cation concentration is expressed in meq/l.

The *SAR* can be determined more easily than the *ESP*. The *ESP* can however be calculated easily from the *SAR* since they are related as (Richards, 1954):

$$ESP (\%) = \frac{100(-0.0126 + 0.01475SAR)}{1 + (-0.0126 + 0.01475SAR)} \quad (46)$$

Within the range 2-30, *SAR* and *ESP* values are almost equal, so  $SAR = ESP$  is a practical approximation. Outside this range, Eq. (46) must be used.

High *ESP* or *SAR* values are usually an indication of poor physical soil conditions and high *pH*. An easy field method, therefore, is testing *pH* with the indicator phenolphthalein. If this turns pink (*pH* above 8.5), the soil has probably a high *ESP*.

Dispersion problems are generally more severe when the *ESP* or *SAR* values are greater. Dispersed material may be transported by groundwater and will enter the drainpipe. In general, under arid climates, problems are not experienced in soils with *ESP* values below 15 percent. In India, the clay content of soils, for which no envelopes around drains are required, is increased from 30 to 40 percent for soils with *SAR* exceeding 13 (Rajad Project Staff, 1995).

As the salt concentration of the soil solution has an influence on dispersion, the *ESP* of a soil cannot be used as a single indicator of soil stability. Soils having an *ESP* greater than 15 percent will not disperse as long as the salt concentration in the soil solution is high. When this high salt concentration in the soil solution decreases, e.g. due to leaching by rain or irrigation water, dispersion problems may arise (Smedema and Rycroft, 1983).

The sensitivity of soils to dispersion also depends on the type of clay mineral (swelling or non-swelling type of clay). Swelling clay types are more susceptible to dispersion problems than non-swelling clays. But vertisols (strongly swelling and shrinking clay soils) in Gezira, Sudan and elsewhere, are examples of soils which do not exhibit dispersion problems in spite of *ESP*-values ranging from 20 to 25 percent (Smedema and Rycroft, 1983).

In humid areas, where leaching by rain water is dominant, difficulties with soil structure may already arise at *ESP*-values as low as 5 percent, whereas soils leached by irrigation water will usually tolerate 10 percent *ESP* (cf. Table 9).

## WATER QUALITY

The chemical composition of a soil largely depends on the quality of the irrigation water, the amount of rainfall and on the chemical composition of the groundwater. The latter may be recharged by irrigation water, rainfall or seepage, causing the water table to rise far enough to influence the soil.

### Irrigation water

The stability of the soil structure in the arable layer and the root zone depends in the long run on salts added with the irrigation water. In the long run, the  $EC$  and  $SAR$  of the soil solution at field capacity ( $EC_s$  and  $SAR_s$ ) depend on the  $EC$  and  $SAR$  of the irrigation water ( $EC_{iw}$  and  $SAR_{iw}$ ) with which the soil has been irrigated:

$$EC_s = n EC_{iw} \quad (47)$$

and

$$SAR_s = \sqrt{n} SAR_{iw} \quad (48)$$

where  $n$  = factor of concentration of the irrigation water in the soil. It depends on the leaching fraction (the fraction of irrigation water drained).

For high leaching fractions ( $LF \approx 0.3$ ) the  $n$ -value is approximately 2. If the  $EC$  and  $SAR$  are expressed in terms of the saturated paste  $EC_e \approx EC_{iw}$  and  $SAR_e \approx SAR_{iw}$  (Ayers and Westcot, FAO, 1985). For medium leaching fractions ( $LF$  ranging between 0.15 to 0.20)  $EC_e \approx 1.5 EC_{iw}$  and  $SAR_e \approx 1.22 SAR_{iw}$ .

The effect of the quality of irrigation water on the stability of soil structure may be diagnosed on the basis of its  $EC_{iw}$  and  $SAR_{iw}$ -values. Guidelines to evaluate the impact of the chemical composition of irrigation water on the infiltration rate of water into the soil were given by Ayers and Westcot (FAO, 1985). These guidelines, which are summarized in Table 9, may be used to assess the effect of the quality of the irrigation water on soil stability in the arable layer and the root zone.

**TABLE 9**

**Problems with the infiltration rate of water into a soil as related to  $SAR_{iw}$  and  $EC_{iw}$  of irrigation water** (after Ayers and Westcot, FAO, 1985)

$SAR_{iw}$	$EC_{iw}$ (dS/m)		
	No problems	Moderate problems	Severe problems
0 – 3	> 0.7	0.7 – 0.2	< 0.2
3 – 6	> 1.2	1.2 – 0.3	< 0.3
6 – 12	> 1.9	1.9 – 0.5	< 0.5
12 – 20	> 2.9	2.9 – 1.3	< 1.3
20 – 40	> 5.0	5.0 – 2.9	< 2.9

Irrigation with water of low salinity will decrease soil stability if the salt concentration of the soil solution is substantial. Rainwater dilutes the soil solution and may cause greater dispersion than most irrigation waters.

### Groundwater

Salinity problems and dispersion of clays, as encountered in irrigated agriculture, are very frequently associated with an uncontrolled water table within one to two metres below the ground surface. If the groundwater is too close to the surface, it rises by capillary action in dry

periods and salinizes the soil surface. If the groundwater contains salts, a continuous load of salt accumulates into the root zone. The combination of high groundwater with salts especially arises in places where upward seepage occurs. Unless the excess groundwater is removed by an adequate drainage system its level must be kept below the critical depth. This is the depth below which capillary rise can be neglected: about 1 m in sands (because of low capillary rise), about 2 m in most clays (where the velocity is limiting), and 3 m or more in silt loams (with high capillary rise and sufficient velocity).

If the groundwater table is controlled by a subsurface drainage system, both the *EC* and *SAR* of the groundwater ( $EC_{gw}$  and  $SAR_{gw}$ ) may have a profound effect on the structural stability of the soil at drain level. This is because the *EC* and the *SAR* of the soil solution will be similar to the  $EC_{gw}$  and the  $SAR_{gw}$  if the soil at drain level is permanently saturated. However, the *EC* and the *SAR* of the soil solution may be substantially higher if the soil at drain level is unsaturated, and salt accumulates due to capillary rise.

Effective salinity control must therefore include not only adequate drainage to control and stabilize the water table and to prevent salt accumulation in the shallow soil layers, but also a net downward movement of water to prevent salinization by capillary rise.

#### PREDICTION CRITERIA

The prediction criteria defined in the above sections are summarized below. These rules are merely guidelines or recommendations that do not guarantee 100 percent certainty.

- If at drain depth, auger holes can be made only with the use of a screen, because their walls collapse rapidly, installation of an envelope is vital to protect future drains against mineral clogging.
- In cohesionless sandy soils drain envelopes should be recommended under all circumstances.
- Any soil having a cumulative particle size distribution that lies completely or largely in the shaded area of Figure 42, is likely to cause problems with clogging of drains without envelopes.
- In temperate areas, drainpipes do not usually need envelopes in soils with a clay content of at least 20-30 percent, providing that drains are not installed under general wetness.
- Soils with a plasticity index of at least 12 show no tendency to siltation.
- In irrigated areas, drainpipes installed in soils with a clay content exceeding 40 percent do not need an envelope, regardless the *SAR* of the soil solution.
- The need for an envelope in soils with a clay content ranging from 20 to 40 percent depends on the *ESP*, which is approximately equal to the *SAR* of the soil solution (or somewhat higher). This *SAR* is greatly influenced by the quality of the irrigation water and sometimes by the groundwater composition (the latter in case of dominant capillary rise). Generally, no envelope is required in all cases where  $SAR_{iw}$  and  $EC_{iw}$  appear to exclude soil stability problems, following the guidelines specified in Table 9. In cases, where *SAR* and *EC* of the irrigation water and/or groundwater will presumably invoke soil stability problems, an envelope is recommended.
- If there is net upward movement of saline groundwater there will be problems with salinization and dispersion of clays. Maintaining a net downward water movement is the key measure to avoid such problems in soils with or without drainage systems.

# Chapter 7

## Guidelines for installation and maintenance of drainage materials

### INSTALLATION OF SUBSURFACE DRAINAGE MATERIALS

#### Installation procedures

##### *Drainage machinery*

The success of a drainage system does not only depend on the design and the properties of the soil and the envelope. It is also determined by soil wetness during installation, trench backfilling and the general quality of the work.

*Manual installation* of drains and *installation with backhoe machines* are a valid option for small drainage projects. Backhoes make wider trenches than drainage machines commonly used in large projects. They are also used for wide and deep excavations for large collectors. Drainage machines either make narrow trenches in which the drains are laid (trench method) or they put the drain directly into the ground (trenchless method). *Trenching machines* are either wheel or chain trenchers. They are appropriate for a wide range of working depths and widths. *Trenchless machines* can be classified in either vertical or V-ploughs. The trenchless installation method, however, has some practical limitations with respect to drain types, drain sizes, gravel application and installation depth. Therefore, trenchless drainage has not yet been widely implemented in irrigated areas (Zijlstra, 1987).

Installing drains by manual labour or with classic excavators requires a series of successive operations: excavating the trench, installing the pipe, applying the envelope material and backfilling the trench. These operations are done simultaneously by trenching machines. Sometimes, backfilling is done by a separate auger or blade on a tractor. Backfilling can also be done by an implement, attached on the drainage machine when driving backward to begin excavating a new trench (Ochs and Bishay, 1992).

Contemporary drainage machines are equipped with laser grade control, which has significantly contributed to the efficiency and accuracy in the installation of subsurface drains. The maximum digging speed, however, should be adjusted to the speed of the hydraulic system that is used for automatic depth regulation, otherwise the installation accuracy will be poor. Although a certain deviation from the design grade can be tolerated, it should not exceed half the pipe diameter. Larger deviations promote air locks in high and sedimentation in low places, which obstruct water movement through the drain. Similarly, drain sections with a reverse grade cannot be tolerated.

##### *Blinding*

Since the risk of sedimentation is largest during installation and in the immediate subsequent period as long as the backfill has not settled and stabilized, drains are normally covered with

friable topsoil to create a stable and highly permeable soil surround, and to preserve the alignment. Therefore trenching machines are equipped with cutters to bring a layer of topsoil or soil from another suitable layer from the sides of the trench on top of the drain. Its thickness should be at least 100 to 250 mm, depending on the drain diameter. Granular envelope material (like gravel) can also be used to achieve a highly permeable drain surround and to prevent vertical and horizontal displacement once the pipe is installed. Any envelope material to be used must be in place around the pipe before blinding is done.

Blinding, the initial covering of the drain with topsoil, is not recommended when organic envelopes are used, because topsoil with organic matter and intensive microbiological activity enhances the risk of microbiological decomposition of these envelopes. In such cases, soil from another suitable layer, with low organic matter, can be used for blinding. Further backfilling of the trench should be done as soon as possible and, at the latest, at the end of each day if there is a risk of surface water entering the trench.

### ***Soil conditions***

Since soil cohesion is strongly correlated with its water content, installation of the drainage system should preferably be done in unsaturated soil conditions with the water table below installation depth and outside periods of general wetness. In addition, the backfill should have settled before heavy rain or irrigation. In some situations, however, these conditions are not, or cannot be fulfilled. Drainage installation in wet conditions is discouraged, yet it is not always possible to drain under favourable or ideal circumstances.

When *cohesionless soils* are drained in saturated conditions, an envelope must be wrapped immediately around the drain and the drain covered with backfill material before the liquid sand flows into the trench. Caving of the trench wall, which often occurs in cohesionless or low cohesive soils, may damage and/or displace the drain. In every case, the drain and the envelope should be in place before the trench box has passed. Possibly, a longer trench shield may be used to protect a greater length of the trench. The drain should be blinded immediately. Simultaneous and instantaneous backfilling will help to prevent trench wall failure. However, the trench may collapse as soon as the trench box has passed and, therefore, a chute should be provided at the end of the trench box to convey the caving soil down to the top of the drain in order to avoid damage by falling clods and stones.

In cohesionless soils, drainage machines should be kept moving at all times. If not, fluid sand is likely to enter the trench box and cause problems with sedimentation as well as with alignment and grade of drains (Ochs and Bishay, 1992). Many problems, encountered with trenchers or backhoe excavators in saturated cohesionless soils, can be avoided by trenchless drainage installation.

Drainage of physically stable, *well-structured soils* under general wetness may destroy the soil structure during excavation and create a less permeable trench backfill (Stuyt, 1992a). Moreover, such conditions also promote mineral clogging of pipe and envelope. In any case, the use of an envelope cannot compensate for the 'adversely affected' soil conditions. Every effort should be made to preserve the existing soil structure and to protect the drain from soil failure. Adjusting the forward speed of the machine can be done to limit the destruction of the soil structure. Observation of the condition of the excavated soil can be a guide to the proper machine speed. The machine should move fast enough to preserve the structure of the soil and not turn the excavated soil into slurry (Stuyt and Willardson, 1999).

Structural deterioration of an originally stable, well-structured soil can be avoided with trenchless drainage installation. The functioning of drains installed with the trenchless technique depends very much on the changes in soil structure brought about by the passing of the blade (Zijlstra, 1987). This depends on the soil, the circumstances (not wet) and the depth (not over approximately 1.5 m). Drainage of clay soils in wet conditions will unavoidably result in smearing and reduction of the hydraulic conductivity where the machine has physical contact with the soil. Drainage of cohesive soils in wet conditions must be avoided, regardless of the available drainage machine.

The installation conditions for laterals of a composite drainage system in saturated soil are improved if the time span between the installation of “permeable” collectors and installation of the laterals is long enough. This is because much of the local groundwater has the opportunity to drain out before the laterals are installed. In severe cases, where the construction of collectors is difficult because of quicksand, a temporary drain (at greater depth) may be helpful. It is usually far cheaper than using well-points.

### **Backfilling**

Backfilling and finishing of trenches should ensure a minimum of later land subsidence and preclude the occurrence of piping. The piping phenomenon may occur as a result of internal erosion of trench backfill by water flowing from the soil surface directly to the drains through the loose backfill material (Van Zeijts and Zijlstra, 1990). This is crucial in irrigated lands, where irrigation water that can flow freely through the trench or drain plough fissures into the drainpipe, will dramatically lower the irrigation efficiency. Furthermore, soil piping may cause soil material to be carried by the flowing water into the drain, creating sinkholes at the soil surface and/or mineral clogging of drains and envelopes, if present. Proper backfilling of the trench or plough fissures is therefore essential. It is easier to backfill and compact V-plough fissures than trenches. Fissures, created by vertical ploughs cause the most problems (Van Zeijts and Naarding, 1990).

Neither heavy loads, nor significant flooding should be imposed on newly installed drains until the soil in the trench is consolidated. The loose backfill material will settle naturally with time. Since backfilling is usually done with a tractor equipped with a dozer blade, passage of the tractor wheel over the backfilled trench, filling it up, and running over it again will speed up the process, yet care must be taken to avoid crushing the pipe. This procedure ensures that only the top part of the trench backfill is compacted, and that the deeper part of the backfill retains a good permeability and a low entrance resistance. In case of trenchless drain installation with a vertical plough, compaction of the upper part of the disturbed soil is equally important. A common procedure is that one track of the drainage machine runs over the drain line on its way back to the outlet drain to begin installing the next lateral. In dry soil, the rate of compaction following this procedure may not be sufficient. Application of irrigation water to unconsolidated material in trenches to settle the backfill is a practice that should be done very cautiously, however.

If a field is to be flood irrigated before the trench backfill is consolidated, direct entry of uncontrolled surface water into the trench should be avoided by raising temporary ridges along both sides of the trench (Stuyt and Willardson, 1999).

### **Guidelines with respect to drainpipes**

Trenching machines can install clay, concrete, or plastic pipes. *Clay and concrete pipes* are manually placed on a chute that conveys the tiles down into the trench shield where they automatically move into the right position on the bottom of the trench. The tiles should be installed

in the trench in such a way that a perfect junction between drains is obtained. For drains of larger sizes, an inspector, standing or sitting in the shield, checks for correct laying. The maximum gap between drains may not be more than 3 mm except for sandy soils or soils with a sandy layer on drain depth where it should be not more than  $2d_{85}$ . Clay and concrete tiles without gravel or appropriate synthetic envelopes are not recommended in cohesionless fine sand (CPVQ, 1989).

*Plastic drains* are normally fed through a conducting pipe, mounted just behind (wheel trencher) or above (chain trencher) the digging mechanism of the trencher. Trenchless machines have been developed to install only corrugated drains of not too large a diameter. They should not be installed with a curvature radius less than five times the pipe diameter, particularly if the pipe is wrapped with an envelope.

For machine installation, the quality of drainpipes is of utmost importance. Drainpipes with fissures, cracks or other visible shortcomings and badly formed pipes or torn envelope material, which do not allow a proper installation or assure a reliable performance, should not be used. Furthermore, all drains and collectors must be closed at the upward end to avoid soil invasion (see Chapter 2, Section *End caps*). Failures that may occur during installation of corrugated drains are crushed or collapsed pipes, twisted pipe sections, couplings pulled apart and snapped-off pipes (Van Zeijts and Zijlstra, 1990). In such cases, the discharge is obstructed. Although the water may finally find its way through the soil to a properly functioning downstream part of the drain and to neighbouring drains, stagnation occurs. Upstream the blockage, water may stand above the drain and a higher groundwater table will result.

Coils of smaller diameter pipes are usually carried on a reel on either trenching or trenchless machine and wound off as installation proceeds. Larger diameter pipes are usually laid out on the field beforehand, and then guided through the trenching machine.

Excessive pulling can result in connections becoming loose or pipes breaking off. During the uncoiling of the pipe, pipe breakage can be easily overlooked, yet the missing piece of drain will cause local wetness. Therefore, trenchless drainage machines must be equipped with guides to facilitate smooth entrance of the drainpipe into the feeder tube. Gravel envelope application can entail substantial, undesirable elongation of the drainpipe if the gravel does not flow smoothly downward through the supply tube.

While cleaning corrugated PVC drains by jetting (Section *Maintenance of drainpipes*), it is sometimes observed that drains were not laid in a straight line, but spiralled slightly. This phenomenon is attributed to the tension in the pipe material generated in the unwinding of the rolls at installation (Van Zeijts, 1987), and may enhance the development of unwanted airlocks inside the drain.

PVC pipes should not be installed at temperatures below 3°C because of their brittleness at low temperatures. Storage at temperatures exceeding 40°C for PE and 80°C for PVC pipes, as well as installation at temperatures above 40°C should be avoided in order to prevent pipe deformation as a result of load and longitudinal stress. Exposure to UV rays of solar radiation also affects the strength properties of corrugated plastic pipes (Desmond and Schwab, 1986; Dierickx, 1998a). Stored pipes should therefore be protected from the influence of direct sunlight if not installed within one week (tropical climates) or one month (temperate climates) after delivery (see Chapter 2, Section *Plastic drainpipes*).



### Guidelines with respect to envelopes

Whatever envelope material is used, and by whatever method it is installed, envelopes must fully surround a drainpipe, unless the drain is installed on an impervious layer. An envelope merely on top of a drain does not suffice because mineral clogging also occurs from underneath if water enters the drain from all around. Bulky envelopes can be spread out by hand in the bottom of the trench before the pipe is placed, but this is only possible in stable soil where trench walls do not collapse. If drains are laid by hand and a layer of the bulky envelope should surround the drain, the envelope is placed on the bottom of the trench and levelled first. Next, the drain is installed and covered further with bulky envelope to the required height. This also holds for machine installation of drains with a bulky envelope. Envelope strips, delivered on rolls, should be applied below and on top of the drain. The material at the bottom needs not necessarily be the same as the material on the top. Prewrapped drains, however, are preferred since they protect drains from all sides, and offer a greater safety than bulky envelopes or envelope strips can do. Envelopes that are good and reliable, however, will only be successful if properly installed under favourable physical soil and weather conditions. Slurry in the bottom of a trench will cause immediate and complete failure of the envelope material and hence of the drain.

The general use of *gravel* envelopes has decreased continuously in spite of all efforts to mechanize and perfect installation by e.g. introducing a gravel auger at the end of the trench box. This gravel auger reduces pipe stretch but gravel-feeding problems are still not completely solved (Vlotman *et al.*, in press). Theoretically, it is also possible to apply gravel with the vertical drain plough as well as with the V-plough. However, the risk of stagnation of gravel in the supply tube of the machines makes the trenchless technique less suitable for gravel installation. The installation of gravel remains a difficult and labour-intensive operation. Practical experience shows shortcomings causing base soil intrusion and pipe siltation. The major shortcomings are (Dierickx, 1993):

- segregation during transportation and installation;
- flow problems in the supply tube;
- unequal distribution around the drainpipe; and
- accidental incorporation of soil into the gravel on the bottom of the stockpile.

Coarse, well-graded *sand* can also be used as a drain envelope. However, the shear resistance of sand, especially if it is not completely dry, will hamper mechanical installation even more seriously than gravel does.

*Organic and synthetic envelopes*, pre-wrapped around corrugated drainpipes can be installed adequately with both trenching and trenchless machines. They are however prone to damage, caused by transport and/or rapid machine installation, especially when materials of inferior quality are used or when the pipe is not carefully wrapped. In order to avoid local spots of soil particle invasion, prewrapped envelopes cover the entire drain circumference. Furthermore, they should not be damaged during handling and installation. Therefore, the layer of loose material before wrapping should be sufficiently thick and as uniform as possible to avoid open spots.

*Geotextiles* that are used for the wrapping of drainpipes are usually supplied on rolls. The sheets should be wide enough to facilitate adequate overlap so that the pipes are completely wrapped, without open joints. If both longitudinal edges of a geotextile sheet are sewn, the sheet should be wide enough to facilitate this. If a geotextile sock is pulled manually over the drain laid out on the field, both the geotextile and the seam, if any, should be strong enough to resist this

handling without damage. Geotextiles usually have adequate mechanical strength to resist mechanical loads during installation.

Machine installation requires adequate drainage materials to assure a straightforward installation and a proper drainage performance. Therefore high-quality materials are required and their properties need be checked prior to installation according to well-considered standard specifications. Quality standards of drainpipes and drain envelopes are therefore of paramount importance (Chapter 9). Neither PLMs nor prewrapped geotextiles show particular problems during installation with both trenching and trenchless machines. Their light weight makes them suitable in soft soils where the use of gravel creates problems because of the weight of the gravel.

## MAINTENANCE OF DRAIN PIPES

### Jet flushing

Maintenance is obvious when there is severe clogging. If done regularly it may extend the service life of the system and enhance its performance. In case of light obstructions in pipes (like fresh ochre) *dry rodding* may be helpful: a long series of coupled rods, with a scratcher at the end, is pushed into the drain and removed later. If done during a period of considerable discharge, the loosened materials will be discharged. For more serious forms of clogging, *jet flushing* has to be used. Jet flushing is a technique used to remove clogging and precipitating agents (e.g. soil particles and microbiological deposits, including iron ochre) from drainpipes through the impact of water jets. More particularly, the functions of jet flushing are:

- lifting of blockages inside the pipe drain;
- removal of deposits from the inner wall surface of the drain;
- cleaning of clogged perforations;
- removal of loose smaller roots of agricultural crops and weeds; and
- supply of sufficient water to carry the loosened agents, including sand and clay particles towards the drain outlet.

Ideally, the water that discharges from the drain evacuates the major part of the clogging agents. Particles, larger than approximately 75  $\mu\text{m}$  may be dislodged, yet are generally too heavy to be removed from the drain (Busser and Scholten, 1979). It is not clear to what extent pipe perforations can be cleaned efficiently and non-destructively. It is assumed that jet flushing has a negligible effect on clogged envelopes.

A typical jetting device is operated from the power takeoff of an agricultural tractor. It consists of a pump, a suction pump inlet, and a reel with a 200-400 m long pressure hose fitted with a nozzle, as shown in Figure 43. The nozzle is fed into the pipe drain from the downstream end. Therefore, the pressure hose is pointed to the drain outlet with the help of an adjustable hose guide. Access of the outlets of laterals is easy if they discharge into open collector ditches. Contrary to these singular drainage systems, as common in humid temperate zones, drainage systems in semi-arid countries often have a composite layout, whereby laterals discharge into pipe collectors instead of open collectors. If the junctions between laterals and collectors are located at manholes, these can be used to accept a jetting hose, provided that the diameter of the manhole is at least 0.3 m. In some countries, e.g. Egypt, laterals are accessible at their upstream end (Figure 14).

**FIGURE 43**  
**Jet flushing with a medium pressure unit (after Bons and Van Zeijts, 1991)**

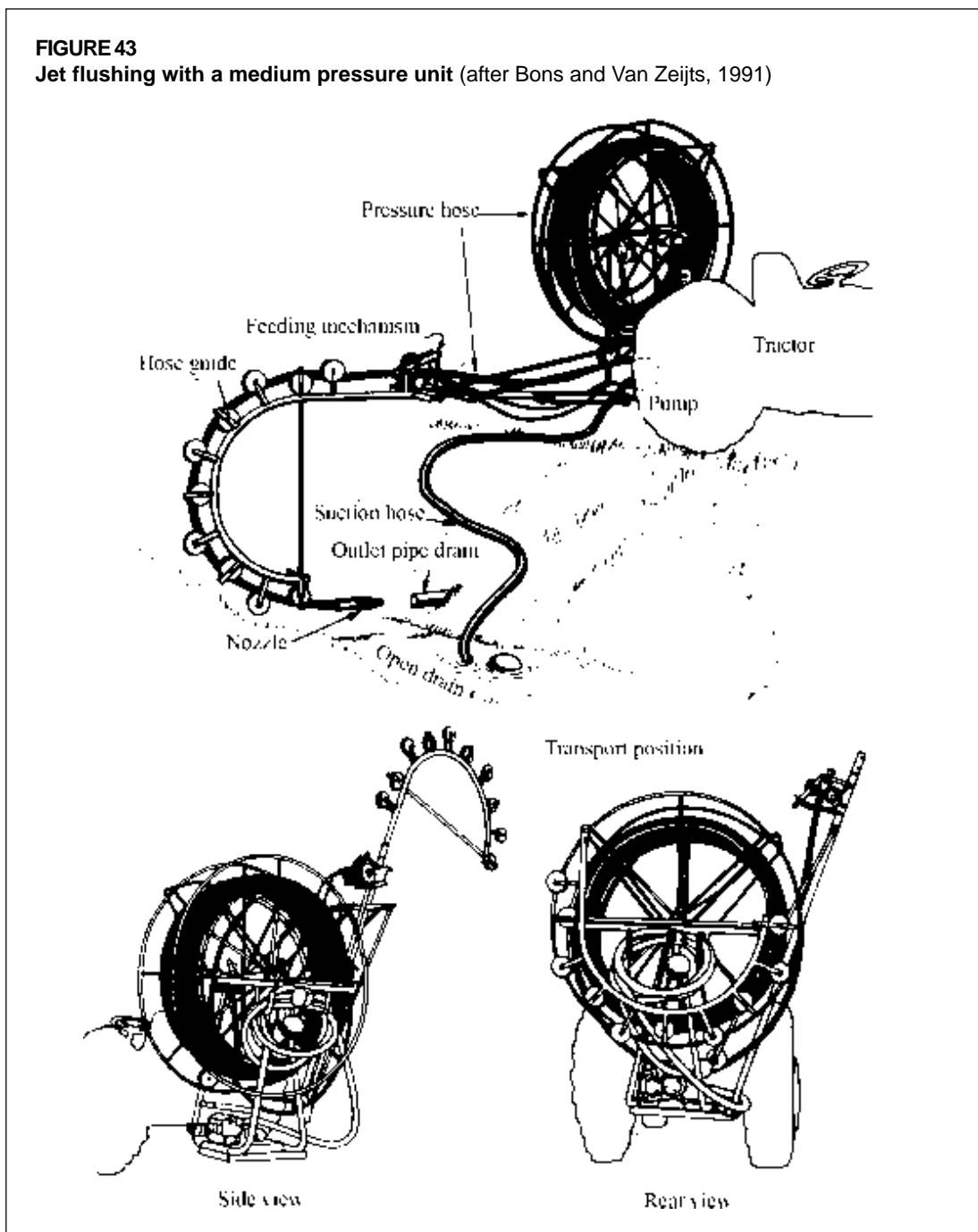

On average, jetting requires 1-2 m<sup>3</sup> of water per 100 m of drain. The water can be pumped from a drainage ditch, an irrigation supply canal, or a tanker must supply it. Saline water is a harsh and corrosive environment for flushing machines. If saline water must be used, the flushing machine should be made of high quality salt resistant machine parts. The use of salt water for flushing must be avoided: it damages the soil structure around the drain and it is harmful for the machine.

During the jetting procedure, the nozzle must be inserted into the pipe as fast as possible. The pulsating action of the piston pump enhances the forward movement of the nozzle. After the

nozzle has reached the upstream end of the drain, the hose is retreated by reeling, at a steady pace of approximately 0.3 m/s while pumping continues (Van Zeijts and Bons, 1993). The cleaning action is influenced by the cleaning force, the angle of attack of the water jets, the duration of cleaning, the water temperature and the use of chemicals (Heeres *et al.*, 1985). The cleaning force is proportional to the flow rate times the square root of the water pressure at the nozzle (Lechler, 1980). Environmental restrictions as well as cost considerations generally preclude the use of chemicals while jetting.

A balance must be found between the pressure and the flow velocity of the water jets coming from the nozzle, preferably on site. The optimum ratio is likely to depend on the inside diameter of the drains; however, no data are available to support this assumption. On many commercial jet flushing units, the ratio between flow rate and pressure can be adjusted. Flow rates are adjusted by changing the pumping speed. The water pressure is adjusted by selecting an appropriate nozzle (number, size and orientation of holes).

Jet flushing will temporarily increase the water pressure in the drainpipe and thus in the surrounding soil, possibly affecting soil stability around the drain. The increased water pressure causes a reduction of cohesive forces between soil particles, which may lead to instant and hazardous quicksand conditions. Notably in weakly cohesive soils, there is a risk of the development of quicksand. After the nozzle has passed, structureless soil material may flow into the pipe. In addition, the hydraulic conductivity of the soil may be adversely affected. Regardless of the discharge from the nozzle, dislodged substances are more easily evacuated from small than large diameter drains due to the higher flow velocities in the smaller diameter pipes.

As far as the water pressure is concerned, three categories of jet flushing units are being manufactured:

- high pressure equipment : > 100 bar at the pump;
- medium pressure equipment : 20-35 bar at the pump;
- low pressure equipment : < 20 bar at the pump.

High-pressure units cannot be recommended, because empirical experience evidenced that this type of flushing machine destabilizes the soil around the drain and destroys its structure.

Water pressure at the nozzle is approximately 50 percent of the pressure at the pump. Hydraulic data of nozzle, pump pressure, and flow rates provided by a commercial flushing unit manufacturer for a flexible hose with an inside diameter of 20 mm and a length of 300 m, are given in Table 10 (Bons and Van Zeijts, 1991). The highlighted line contains recommended figures (i.e. pressures and discharges).

**TABLE 10**  
**Relation between pump pressure, nozzle pressure and discharge for a flexible hose with an inside diameter of 20 mm and a length of 300 m** (after Bons and Van Zeijts, 1991)

Pump Pressure (bar)	Nozzle with 2-mm holes		Nozzle with 1.5-mm holes	
	Pressure at nozzle (bar)	Discharge (l/min)	Pressure at nozzle (bar)	Discharge (l/min)
20	3.2	47	6.0	50
25	4.5	65	8.5	56
30	5.5	70	10.0	61
35	6.7	76	12.5	67
40	8.0	82	14.5	71
45	9.5	87	16.5	76
50	10.0	90	18.5	80

The maximum flow of water that can be employed depends on the cross section of the drain. Empirically it was found that a discharge of approximately 70 l/min is satisfactory for 50 to 70 mm pipe diameters. Such discharges are indeed realized with the highly popular medium pressure units. Higher discharges may force too much water through the pipe perforations, which is hazardous for the envelope and the structure of the abutting soil.

The cost/benefit effects of regular maintenance of drains by jet flushing are hard to quantify. Still, some figures may be informative. The cost of jet flushing in The Netherlands, at medium pressure, is approximately US \$0.15 per m of drain which is 12 percent of the installation cost of \$1.25 per m. With a typical drain length of 800 m per hectare and a flushing frequency of once in every three years, the annual cost amounts to \$40 per hectare per year. The average annual gross yield of arable land is approximately \$2500 per hectare. The calculated maintenance cost is therefore less than 2 percent of the annual gross yield.

### **Empirical experience with jetting in northwestern Europe**

Dry rodding and jetting of drains are useful for removing ochreous substances but generally not for removing roots from drains, with the exception of loose, tiny ones (agricultural crops, some weeds). Before jetting, some drains should be examined internally first, e.g. with a miniature video camera, in order to check the kind of clogging and to assess the jetting efficiency. In case of ochreous substances, preventive jetting may be useful in order to prevent total blocking of pipe perforations. Ochre is a soft substance when precipitating, but becomes dense and sticky with time, making it difficult to remove (Cestre and Houot, 1984). Jetting cannot generally re-open pipe perforations that were clogged with encrusted ochreous substances. Ochre deposits should therefore be removed before drying out by frequent flushing with medium pressure (Von Scheffer, 1982). Based on recently acquired experience in The Netherlands, this recommendation is nowadays relaxed somewhat in the sense that flushing is recommended only if the ochre deposits do noticeably impede proper functioning of the drain. This recommendation also holds for other kinds of microbiological deposits inside drains.

The following conditions may enhance the risk of drain sedimentation through jetting:

- the use of high pressure equipment;
- jetting shortly after drain installation (soil not yet settled nor stabilized);
- damaged pipes and/or decomposed envelopes;
- non-cohesive and weakly-cohesive soils; and
- slow pace of movement or (temporary) blockage of the nozzle.

In The Netherlands, approximately 600 000 hectares of agricultural lands are provided with a subsurface drainage system. No precise data about the area periodically flushed is available. In 1998, the number of flushing units in operation was estimated at several thousands, so a considerable area is regularly maintained. The medium pressure unit (35 bar at the pump and 10 to 15 bar at the nozzle, highlighted in Table 10) is by far the most widely used.

In the past, jet flushing has been reported to have a positive effect on drain performance in a pilot area, where drains were prone to excessive biochemical clogging due to intense upward seepage of ferrous groundwater (Ven, 1986). As long as the drains were jetted periodically, the drainage system met the design criteria in terms of drawdown of groundwater and discharge. After jetting was discontinued, the plots suffered from waterlogging. Van Hoorn and Bouma (1981) investigated the effect of jetting on drains, installed in clay soils, which had been submerged regularly and clogged by mineral particles and biochemical substances. The effect was quite

positive. At another pilot area in The Netherlands with comparable conditions, however, Huinink (1991) established that drain performance could not be restored, despite the implementation of an extensive jetting project.

Experiences with high-pressure equipment in northwestern Europe are unfavourable, while substantial pipe sedimentation is occasionally reported with intermediate pressure equipment (Brinkhorst *et. al.*, 1983). Practical experience of farmers and contractors learned that flushing with high pressures enhances sedimentation rates. The next flushing had to be done sooner than in case medium or low pressure was used. Around 1980, therefore, the use of high-pressure equipment was gradually discontinued.

During the nineties, the frequency of jet flushing as advised to the farmer varied from annually to once in every five years. During this decade, farmers have gradually become somewhat suspicious towards jetting of drains. Intense monitoring of drain performance in various pilot areas revealed that the assumed beneficial effects were not so obvious as was assumed for a long time (Huinink, 1991). If any improvement in drain performance could be noticed at all, it would generally last for a very short time. This fact has induced some reluctance towards preventive jetting of drains.

Drainage experts nowadays give the following advice to the farmers: do not jet any drain as a form of preventive maintenance, unless there is a substantial risk of ochre clogging. On the other hand, jetting is useful if the performance of drains has significantly deteriorated, as observed by the farmer. Drains, prewrapped with suitable and lasting envelopes should however be practically maintenance free (Dierickx, 1993). A likewise observation was made in the United States some 20 years earlier (Winger, 1973).

Because of this development, the number of Dutch manufacturers of high and medium pressure equipment went down from six in 1991 to two in 1998. Comparatively simple low pressure jetting equipment is however manufactured at various locations.

### **Guidelines for jetting**

In summary, the following guidelines for jetting were empirically developed in Denmark, Germany and The Netherlands for various types of drainpipes with diameters ranging from 40 to 90 mm:

1. Jetting must preferably be done when the groundwater table is at or above drain level. This is because wet sediment is easier to remove, and because a wet soil will restrict the undesirable penetration of the jetted water into envelopes and soils.
2. Satisfactory results were achieved with the following machine specifications and settings:
  - a middle pressure pump (35 bar at the pump and 12 to 15 bar at the nozzle);
  - a standard nozzle with one hole forward and 12 holes backward;
  - a flow rate of 50 to 70 l/min;
  - an advance (penetration) rate of 0.5 m/s; and
  - a withdrawal rate of 0.3 m/s.
3. When the movement of the nozzle is obstructed, the pump should be stopped immediately to prevent local physical damage to the drain, envelope, and to the soil structure.
4. Neglected drains that contain hardened clay and silt deposits should be jetted with a special nozzle with less yet larger diameter holes (e.g. one forward and four to the rear). The high impact water jets will 'cut' grooves in the sediments, breaking them up into pieces, which facilitates their removal.
5. Sediments consisting of fine sands must be removed with a nozzle with smaller jet angles, e.g. 30°. Wet sand can be loosened relatively easy, but is more difficult to remove from the pipe than deposits that consist of finer particles like silts and clays. The sand must be kept moving by large quantities of water.
6. Drains that are severely clogged should be cleaned in stages with an interval of several weeks. These intervals are required to allow the soil around the drains to stabilize after jetting.
7. If the rate of mineral clogging of drains is so high that installation of new drains must be considered, a last, drastic attempt may be made to restore them. In such cases, the drain must be jetted by repeatedly inserting and pulling back the nozzle, each time a few metres further, whereby application of high pressures may be considered. In order to minimize the risk of destabilizing the surrounding soil, the speed of insertion of the nozzle into the drain should be maximum with low water flow, whereas the pace of withdrawal and the pumping rate should be such that the sand is kept in front of the jet sprays. It is crucial to establish and maintain a substantial discharge velocity in the drain.





## Chapter 8

# Research on drainage materials

The first information from research on drainage materials came from studies, made with analogue sand tank models (Wesseling and Homma, 1967; Segeren and Zuidema, 1969). Sand tank model research has contributed to the identification of relevant parameters. Theoretical studies (Widmoser, 1968; Nieuwenhuis and Wesseling, 1979) and electrolytic model research (Dierickx, 1980) on pipe and envelope characteristics have resulted in their quantification and have increased the knowledge in this field. Relevant practical information on the need of drainage envelopes, i.e. the retention of soil particles in envelopes was obtained from permeameter research (Samani and Willardson, 1981; Dierickx and Yüncüoglu, 1982; Stuyt, 1982; Lennoz-Gratin, 1987).

The material discussed in this chapter deals almost exclusively with drain envelopes, because envelopes are an integral part of many subsurface drainage systems. If they fail, the whole drainage system fails. Problems concerning the application of drain pipes are limited and well understood. Frequent problems and an ever-expanding choice of materials make drainage envelope research important.

There are two categories of investigations into the functioning of drain envelopes, which are not always clearly distinguished. These categories are:

- ‘*black box*’ investigations intended to evaluate the suitability of specific envelopes rather than to understand the factors which determine their applicability; and
- investigations which are intentionally made to try to *reveal the factors* and to define the associated parameters which determine the applicability of envelope materials in general terms.

The first category may be labelled as *evaluation of envelopes*, the second as *fundamental research on envelopes*.

Testing of drain envelopes is usually conducted in two consecutive steps, namely examination in the laboratory and subsequently in the field. Thus, promising envelopes – as based on laboratory test data - are subjected to field performance tests. In the following, guidelines have been drafted for laboratory and field research projects. The components of these guidelines are discussed and a family of practically oriented *do’s* and *don’ts* concerning the set-up and the monitoring of conducting laboratory experiments and pilot areas is established.

Prior to setting up a research project (laboratory as well as field research) to investigate the suitability of envelope materials for a specific application, it should be considered which question(s) can be answered, and which questions cannot.

### RELEVANT SOIL CHARACTERISTICS AND ENVELOPE PARAMETERS

Research on drainage materials (both laboratory and field research) requires that the specifications of the envelope and the relevant soil characteristics are well known. The performance of an

envelope is largely determined by physical and chemical soil properties. Permeameter tests should therefore be carried out with soil of the experimental field where the drains will be installed, taken at drain depth, or with soil that will be used to blind the drains. When permeameter research is carried out, it is also important to know and control the soil conditions (moisture content, bulk density etc.) in the permeameter, so that the field performance can be predicted in relation with installation conditions. To evaluate drainage envelope materials from field research, the soil in which they will be installed as well as the applied envelope material should be clearly specified. The following physical and chemical properties of the soil and the envelope specifications in both laboratory and field research should therefore be determined.

Relevant *soil* characteristics (see Chapter 6, Section *Physical properties of the soil*) are:

- particle size distribution (soil texture);
- plasticity index, which requires the determination of the liquid limit and the plastic limit;
- soil density (for permeameter research only); and
- salinity and sodium, calcium and iron content of the soil and of the irrigation water.

Relevant parameters of *synthetic envelopes* (see Chapter 3, Section *Specifications for prewrapped envelopes*) are:

- thickness;
- characteristic opening size (preferably  $O_{90}$ ) or the whole pore size distribution curve (which gives more specific information); and
- water penetration resistance (occasionally).

Relevant parameters of *granular envelopes* (see Chapter 3, Section *Specifications for gravel envelopes*) are:

- particle size distribution; and
- chemical components.

#### LABORATORY ASSESSMENT OF ENVELOPE APPLICABILITY

Testing of large numbers of envelope materials in the field is time consuming and expensive. Therefore some kind of analogue modelling can eliminate envelope-soil combinations that are obviously unacceptable. Analogue models, i.e. sand tanks and flow permeameters, have been extensively used for this purpose. A review of the development of analogue modelling of envelope functioning in The Netherlands is given by Stuyt (1992a).

#### Sand tank models

In the 1960s, sand tank models were quite popular in The Netherlands. These models were used primarily to investigate the entrance resistances of various sorts of pipes, like clay tiles, smooth plastic pipes and corrugated plastic pipes. Standards for corrugated pipes were not established yet, and the experiments were focused on perforation patterns and some envelope materials. Later on, sand tanks have been used extensively to test envelopes.

Sand tank models have led to useful results:

- All investigations carried out in sand tank models confirm the favourable effect of drain envelopes (Watts and Luthin, 1963; Feichtinger, 1966); even of sheet envelopes.

- The entrance resistance decreases with increasing envelope thickness (Wesseling and Homma, 1967; Segeren and Zuidema, 1969).
- Studies with sand tanks revealed that the number, shape, and size of perforations affect the entrance resistance less profoundly than does the envelope material.
- Luthin and Haig (1972) proved that a suitable gravel surround acts as a completely permeable drain, making gap spacing of clay and concrete pipes virtually unimportant.
- Investigations into the hydraulic performance of drainage systems with partial surrounds indicated that there is not so much difference compared to complete surrounds (Segeren and Zuidema, 1969; Saulmon, 1971; Dennis and Trafford, 1975). Yet, in many cases complete surrounds are safest in preventing excessive pipe sedimentation.

Despite their usefulness, accurate study with sand tank models is very difficult (Wesseling and Homma, 1967). Drainage materials can only be compared when the investigations are carried out under strictly similar circumstances. Wesseling and Van Someren (FAO, 1972) assessed the disadvantages of sand tank models as follows:

- The drainage materials are tested in a rather short time. Wesseling and Homma (1967) however found that the entrance resistance of subsurface drains increased with time.
- Results are closely connected with the way the analogue model is filled with soil material. To obtain consistent data, very homogeneous sand has to be used. This makes it difficult to gain insight related to the properties of the material to be expected over a long period in practice, where field conditions may differ widely from the laboratory conditions.

Conventional sand tank models were quite large, e.g.  $1.5(L) \times 1.0(W) \times 1.0(H)$ m. They were filled with cohesionless sand or cohesionless soil types originating from, or similar in texture to the soil of the area to be drained. A large amount of sand was required to fill such models. Moreover, the filling had to be done as homogeneously as possible, which was quite labour-intensive. Therefore most experimentally used soils contained only a small percentage of clay and silt particles and organic matter, and were, as such, often different from most soil types that were found in the field. If the envelope performed well in a test, it was recommended for field use. In many sand tank experiments, the objective was to quantify the entrance resistance, yet in reality, an 'approach flow resistance' was recorded. In addition, the sand-tightness was tested and the envelope was accepted for use in practice if no substantial passage of mineral particle was observed.

Laboratory experiments in sand tank models, made in the sixties and seventies, could not give straightforward clues on the performance of drain lines because:

1. envelopes were examined without attempting to understand and analyse the physical processes involved;
2. only sandy soils could be used;
3. envelope parameters like characteristic pore size were not considered;
4. the relevance of presumably important envelope parameters to the functioning of envelopes was not systematically investigated;
5. installation circumstances and soil conditions (moisture content and bulk density) were not covered, hence the reproducibility of the tests was low; and
6. long-term, time-dependent phenomena, like seasonal changes, and the rate of mineral and chemical clogging in the long run (e.g. one year or longer) could not be simulated.

Point 5 deals with the moisture conditions under which the pipes were installed in the sand tanks. Cavelaars (1966) found that the measured 'approach flow resistance' as well as the hydraulic conductivity were quite sensitive to the moisture content of the soil samples the sand tanks were filled with. Indeed, in many sand tank experiments, a substantial decrease of conductivity with time was found near the drain. According to Willet (1962), Van der Meer and Willet (1964) and Koenigs (1964), this decrease is caused by local blocking of soil pores by fine particles, which have been dispersed by the puddling of the soil at high moisture content. A high susceptibility to puddling under wet conditions in the field is found in certain soils high in particles under 50  $\mu\text{m}$ . Decreases in hydraulic conductivity up to a factor 20 were observed; facts that of course appeared to be of great importance for determining the performance of drains in the field.

Drains, installed in other than sandy soils (e.g. loamy and silty soils) may also require envelopes. The physical properties of such soils cannot be easily simulated in analogue models. In these cases, parallel flow permeameters and field experiments are indispensable to examine envelope applicability.

During the First International Drainage Workshop, held in Wageningen, The Netherlands in 1979, Knops and Dierickx (1979) concluded that there was a great need to acquire more knowledge about the most efficient and effective use of synthetic fibre fabrics as drain envelopes. This need was prompted because of the then rapidly increasing availability of synthetic envelope materials. Research that would be more fundamental than the investigations made so far, was required to evaluate the interactions between soils and drain envelopes. It was carried out to deepen the insight into the sensitivity of a soil to internal erosion and the processes influencing soil particle movement. This research was to provide the necessary information to develop a reliable methodology for predicting the need for an envelope in any soil type and for any soil condition. The parallel flow permeameter proved to be a suitable means for this type of research.

### **Parallel flow permeameters**

Permeameter research simulates the flow towards a plain or wrapped drainpipe by one-dimensional flow towards a flat piece of drainpipe, an envelope material, or a combination of both. An example of a permeameter apparatus with upward flow for testing the performance of drainage materials is shown in Figure 44. It consists of a plexiglass cylinder with an inside diameter of 100 mm and a length of at least 150 mm in which a soil sample with a height of 50 to 100 mm is packed. A flat piece of drainpipe wall is used on top of the soil sample as an external support, with the envelope (if any) in between. A spring with support (screen and geotextile or perforated disk) maintains a positive contact, even when small amounts of soil particles are washing out. The hydraulic heads in the system are monitored by piezometers connected to a manometer board. Obviously, the tests should be carried out within a gradient range that is representative for the hydraulic gradients that may develop near the drains in the field. The laboratory tests should be run at progressively higher gradients until the envelope material fails or until the highest obtainable gradient is reached. In this way, the possible failure gradient of the soil-envelope combination can be recorded. Failure can be mineral clogging of the envelope, excessive movement of soil through the envelope material or the collapse of the soil structure, resulting in a substantial decrease in hydraulic conductivity. Conclusion on the performance of a soil-envelope combination may not be based on one single experiment but on a number of replicates, in which soil preparation and filling of the permeameter must be done according to certain rules. Soil aggregates should be passed through a sieve to form aggregate fractions. Then, soil samples are again reconstituted with known amounts of each fraction. The

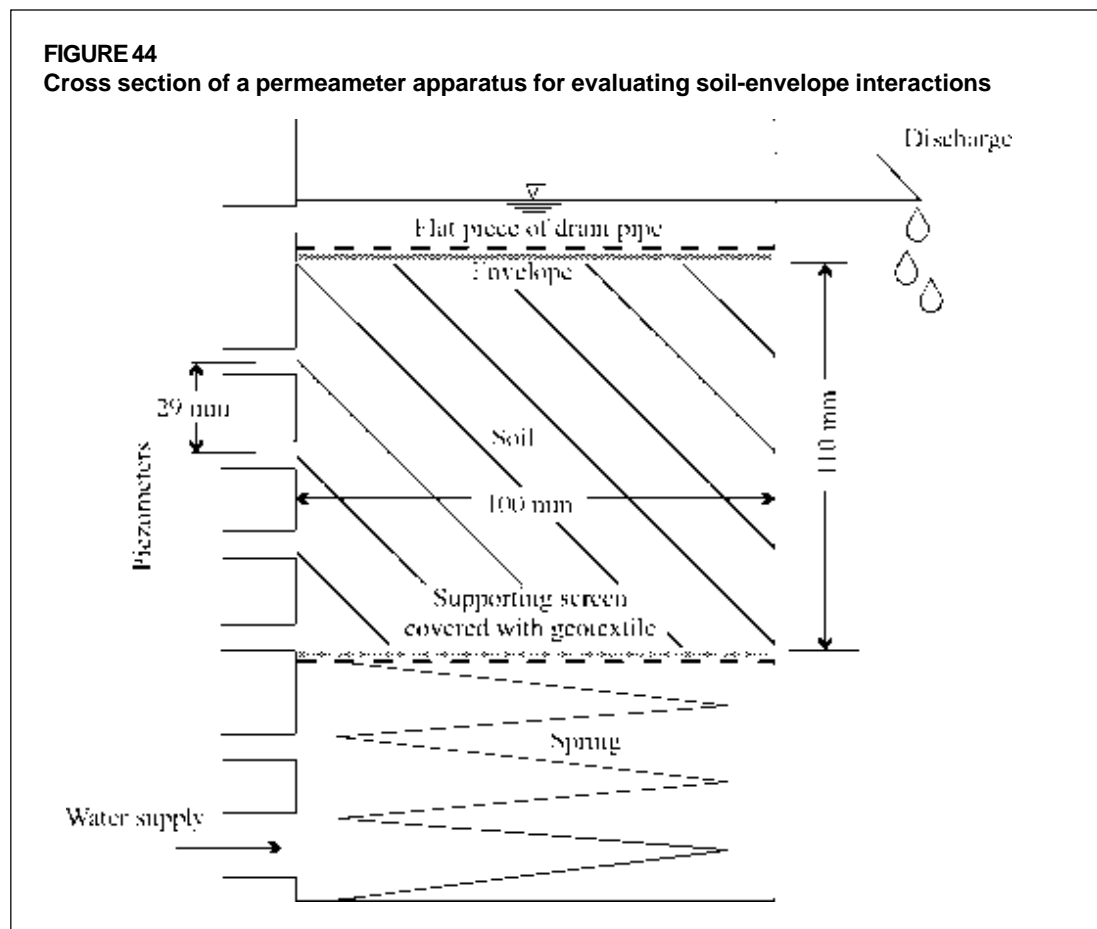

filling of the permeameter with a given soil has to be done in the same way, with the same quantity of soil, and at the same moisture content, in order to obtain the same bulk density for each replicate.

The US Army Corps of Engineers (1977) used a parallel flow permeameter to evaluate geotextile-soil compatibility. This test became known as the 'gradient ratio test', and was accepted as the standard testing procedure for the assessment of the mineral clogging potential of a geotextile-soil combination (ASTM D5101-96, 1996). Willardson and Walker (1979) also designed a parallel flow permeameter that was used by Samani and Willardson (1981) to develop the concept of the hydraulic failure gradient,  $i_f$  (see Chapter 4, Section *Hydraulic failure gradient*). A parallel flow permeameter was used by Dierickx and Yüncüoğlu (1982) in Belgium to gain more information on the performance of envelope materials in structurally unstable soils. It was also used to gain a better understanding of the mechanism of particle migration at and near the soil-envelope interface. In The Netherlands, Stuyt (1982) set up permeameter research to simulate the physical process of particle passage and envelope clogging with structureless soil. Stuyt and Oosten (1986) reported on permeameter research with undisturbed and disturbed samples of weakly cohesive soils. Permeameter research in France (Lennoz-Gratin, 1987) resulted in a standard test method (NFU 51-161, 1990) to diagnose mineral clogging hazards in subsurface drainage systems (Lennoz-Gratin, 1992). Parallel flow permeameters have been used by many engineers and researchers all over the world to get answers on the interaction between geotextile and soil (Qureshi *et al.*, 1990; Fischer *et al.*, 1994; Chin *et al.*, 1994; Shi *et al.*, 1994). Vertical

flow permeameters are used in Egypt (Dierickx, 1988), Pakistan (Dierickx, 1991) and India (Dierickx, 1998c) to assess the applicability of synthetic envelopes and to evaluate the performance of imported and locally made materials with various soil types and at various soil conditions. In Egypt and Pakistan, permeameter research has contributed to the introduction of synthetic envelopes and resulted in the successful use of locally made drain envelope materials in experimental fields.

Parallel flow permeameter models overcome some of the disadvantages of sand tank models and are more suitable to study the physical interaction between envelopes and soils. The reasons are manifold:

- only small amounts of soil material are required;
- both cohesionless as well as cohesive soil may be used;
- the filling with soil can be adequately controlled, hence the repeatability of the tests is high;
- soil conditions, in terms of moisture content and density, can be adequately maintained;
- physical processes in the soil can be simulated; and
- the average hydraulic gradient can be varied and maintained fairly easily.

Parallel flow permeameter testing has proven its validity for assessments of the following phenomena:

- the need of drainage envelopes (Dierickx and Yüncüoğlu, 1982; Lennoz-Gratin *et al.*, 1992);
- functional differences between various envelopes (Stuyt, 1982; Stuyt and Oosten, 1986; Lennoz-Gratin, 1987; Rollin *et al.*, 1987; Stuyt and Willardson, 1999);
- the effect of soil conditions on drainage performance (Dierickx and Yüncüoğlu, 1982; Kabina and Dierickx, 1986; Stuyt and Oosten, 1986; Stuyt and Willardson, 1999);
- retention criteria of envelopes with respect to soil particles and aggregates (Dierickx, 1987; Dierickx and Van der Sluys, 1990; Qureshi *et al.*, 1990);
- the soil retention properties of gravel (Vlotman *et al.*, 1992b), organic and synthetic envelope materials (Kabina and Dierickx, 1986; Stuyt and Oosten, 1986);
- the interaction of a geotextile-soil combination (Stuyt, 1982; Stuyt and Oosten, 1986; Dierickx, 1986b; Dierickx *et al.*, 1987; Lennoz-Gratin, 1987; Rollin *et al.*, 1987; Qureshi *et al.*, 1990; Chin *et al.*, 1994; Shi *et al.* 1994);
- the heterogeneity of flow patterns near drains by means of dye tracers (Stuyt and Oosten, 1986); and
- the textural composition of micro soil samples from the soil core, of soil material entrapped in the envelope, and of the soil material that passed the envelope and drain pipe (Stuyt and Oosten, 1986; Stuyt, 1992a).

Through these analogue model tests, the need of drain envelopes could be linked to soil characteristics (Samani and Willardson, 1981). Simple and useful retention criteria have been assessed for PLM envelopes and geotextiles used as drain envelopes (Dierickx, 1993). Design criteria for gravel envelopes have been redefined based on elaborate tests carried out by Vlotman *et al.* (1992a).

### **Guidelines for permeameter research**

Permeameter tests may be carried through to evaluate a soil-envelope-pipe combination. The results of the permeameter tests will however strongly depend on the way in which the soil

sample is prepared. In implementing permeameter research, a number of crucial guidelines should be considered.

### **1. Soil preparation**

Permeameters should not be filled with dry soil clods, as these tend to burst upon wetting, rendering the soil almost impervious. After passing air-dried soil clods through a 5-mm square hole sieve, they should be brought to the desired moisture content (usually field capacity) by spraying water with a paint gun and then passed again through sieves (e.g. 4.76-, 3.36- and 2.00-mm square hole sieves) to make aggregate fractions. Soil samples can be prepared using e.g. 40 percent aggregates between 0 and 2.00 mm, 40 percent aggregates between 2.00 and 3.36 mm and 20 percent aggregates between 3.36 and 4.76 mm. However, aggregate sieving and soil sample preparation are soil dependent. No general rules can be given on moisture content, aggregate fractions and percentage of each fraction for the various soil types. Too small aggregates of swelling clays may result in an impervious soil when saturated. Therefore, some preliminary research on aggregate size, stability and swelling at various moisture contents may be required.

### **2. Simulate conditions vulnerable to failure**

The soil in the permeameter should not be compacted too strongly because dense soil does not exhibit problems and does not correspond with field conditions where loose, excavated soil is more common, especially in backfilled trenches. The soil condition, moisture content and hydraulic gradient should be simulated as much as possible in accordance with the conditions that are most likely to occur in the field. This is not an easy task.

### **3. Measure after equilibrium has been reached**

After proper filling of the permeameter, the soil is saturated and the air in the permeameter removed. The experiment cannot be started until equilibrium is reached, which usually takes a few hours depending on the soil. At the same time, the soil column should be checked on visual disturbances along the plexiglass wall of the permeameters. Tests which show piping should be discontinued.

### **4. Downward or upward flow direction**

Upward water flow is preferred because then the drag force of the water flow counteracts the gravitational and the cohesive force - if present - and promotes an unstable situation as soon as these opposite forces cancel. Downward flow tends to mechanically stabilize the soil, because the flow force acts in the same direction as the gravitational force.

### **5. Apply increasing hydraulic gradient**

The hydraulic gradient near drainpipes is subject to variation. With permeameters, any dynamic sequence of hydraulic gradients may be simulated. Soil particle passage through envelopes occurs as soon as a critical level is reached. A gradual increase of the hydraulic gradient is a good standard.

### **6. Assessment of soil erosion**

The hydraulic gradient in the soil near the drainpipe determines whether soil erosion will occur. The susceptibility of a soil to erosion can be examined by gradually increasing the hydraulic

gradient. Attempts to estimate the *amounts* of sediment in the field from permeameter tests are useless since the hydraulic and other conditions there may be quite different.

### 7. Relationship between laboratory and field data

Mineral clogging of field drains wrapped with envelopes found to be suitable in earlier permeameter experiments may still occur. In such cases the envelope should not be immediately blamed. First an accurate field survey should be made into other possible causes, e.g. damaged pipes or envelopes, soil invasion during connection with a collector or a manhole, defective connections, ochre formation, etc.

### 8. Interpretation of results obtained with permeameters

Under ideal and well-maintained conditions, results of identical tests should be similar. Permeameter flow tests should therefore be made with three replicates at least, in which aggregate size, moisture content and soil density should be the same. If the test results deviate substantially, additional tests should be made, again in three replicates. When all additional results correspond with the results of two of the first series, a corresponding reliable conclusion can be made. In all other situations, the tests must be redone. If results are widely scattered again while the testing conditions are similar, the envelope must be considered unreliable.

## FIELD ASSESSMENT OF ENVELOPE APPLICABILITY

### Field research

No 'analogue' simulation can fully reproduce the physical processes that occur in the field. Phenomena that require further study in the field are the long lasting behaviour of envelopes due to seasonal changes, chemical and microbiological clogging, peculiar soil invasion processes and root growth.

Combinations of drains and envelopes that come out favourably from a laboratory test should be installed under field conditions to investigate the long term effects mentioned above. They can be tested again to assess their performance in relevant soils and under various installation conditions.

Conclusions on the performance of drain envelopes from field research cannot always be drawn due to a large variability in results because of:

- the variability of the physical properties of the soil;
- uncertain effects of installation (quality of the work and general wetness);
- mineral clogging through damaged pipes and/or envelopes, and defective connections;
- soil invasion during connection with collectors or manholes; and
- ochre formation.

Special attention should be paid to other problems with drainage materials which may affect the results of field investigations. The most frequently occurring problems are:

- loose and/or damaged exit pipes (in systems with open collector ditches only);
- interrupted drains due to poor pipe quality (broken pipe) or detached pipe connectors;
- entrapped air (or methane) inside a drain which has been installed with an irregular grade; and



- challenging soil properties, such as soils with ochreous seepage, acid sulphate soils, low-permeability loam and ‘unripened’ clay soils with very high seepage rates.

Evaluation of the performance of drainage systems in drained lands is out of the scope of this publication, although checking the performance of the drainage materials is a major component of such evaluations. The constraints defined above are more accentuated in this case. Therefore, the selection of the fields to be evaluated should be done after a sound reconnaissance survey of the project area.

### **Guidelines for field research**

A good field research project requires some basic guidelines. These are:

#### **1. Selection of experimental fields**

Experimental fields must be carefully selected in order to reduce the influence of different soil types as far as this is possible and practical. The large variability of soil texture, structure, and condition (e.g. moisture content and bulk density) along the drain lines makes it very difficult to evaluate the performance of an envelope in the field, because the functioning of the entire drainage system, including the effect of the soil near the drain is evaluated. Therefore, it is recommended to try to select a location where soil heterogeneity is known to be small.

One should be aware of regional components of groundwater flow. In any region where a new experimental field is scheduled it must be known or verified if any appreciable rate of deep percolation or seepage exists. Laterally oriented components of groundwater flow that may interfere with a subsurface drainage system may also exist. As long as the intensity of these phenomena is restricted, their interference with the results will also be small. The threat of soil heterogeneity, in combination with percolation and seepage, seriously challenges the validity of the recorded data.

#### **2. Parameters to measure**

Monitoring the effect of one single factor on the composite result of a complex physical process is often difficult. If the impact of one factor notably exceeds the cumulative effect of the other ones, field research is more likely to be successful, because the underlying problem can be investigated more easily.

To determine approach flow resistances and to correlate them to envelope types, drain discharge is measured together with the approach head loss and the total head loss (Figure 23):

- the *approach flow head loss* is measured as the vertical difference between the water level in a piezometer located at a distance of 40 cm away from the drain, and the water level in a piezometer in the drain pipe; and
- the *total head loss* is measured as the vertical difference between the water level in a well tube midway between two drains and in a piezometer in the drain pipe.

Drain discharges and water levels in piezometers are recorded frequently in order to determine the variation of the approach flow resistance (Eq. 6 in Chapter 4, Section *Entrance and approach flow resistance*). To monitor changes of soil and water flow conditions near the drain, right after installation, daily recording is required. If unsteady state flow prevails, daily observations are necessary during the peak period. During tail recession and if drain discharges can be considered quasi steady state, the recording frequency can be lower.

Furthermore, excavations are made in order to check drain clogging rates and the possible microbiological decomposition rate of organic envelopes (Scholten, 1988). Sometimes determination of soil texture and soil chemical properties at various locations is useful to explain differences in the performance of drainage systems. Procedures for field testing of drain lines and processing of collected data can be found in Dieleman and Trafford (FAO, 1976).

### 3. Design and construction of the experimental field

All field parameters which are not associated with drainage materials, but which may affect drainage performance, such as drain spacing and drain depth, should be kept constant because they impose a disturbing 'noise' on the results.

Given the implicit heterogeneity of the soil and the random effects that are induced by the installation of pipe drains, the *use of replicates* of objects under study (mostly laterals) is essential when various envelope materials must be compared. There are, in principle, two options regarding the layout of a field experiment.

- *Laterals, wrapped with identical envelope materials, in contiguous groups of at least three drains.* This layout has the advantage that the interference by laterals wrapped with other envelope materials, is smallest. Hence the data on drain performance will be the most reliable. This is particularly true for the laterals located near the centre of the group. This layout is the most appropriate, despite the risk that soil heterogeneity affects the data.
- *Each envelope is located next to different types.* In this layout, interference between adjacent drains will impose noise on the data. The data may therefore be not very reliable and difficult to interpret. However, this layout has the advantage that the effect of heterogeneity of soil properties is minimized.

To minimize the risk that substantial 'noise' is imposed on the results, it is recommended:

- to have the drains installed by a well-qualified contractor, and
- to use drainage materials that are uniform along the lateral.

### 4. Data collection

Data collection must not start before the soil around the drains has settled. For the collection of data strict guidelines must be observed, because erroneous data will lead to undetected misinterpretation. The frequency of measurement must be adapted to the variability of the parameters with time, e.g. water table depth, hydraulic heads and discharge. The recording frequency of data must be the highest during and after storm events and irrigation supplies. In order to get information about soil heterogeneity it is recommended to install an additional number of piezometers alongside at least one drain. Valid recommendations on how to measure groundwater levels and how to construct piezometers may be found in e.g. Dieleman and Trafford (FAO, 1976).

### 5. Data processing and analysis

The emphasis of the data analysis procedure should be on long-term trends. Small differences in performance between drains are not relevant, because they are probably due to the heterogeneity of the soil profile. Large differences should be analysed carefully before conclusions on envelope performance can be drawn. Suggestions on how to analyse the functioning of drains are given

by many authors, e.g. Wesseling (1967), Kessler (1970), Huinink (1991), and Ochs and Bishay (1992).

In field experiments, it is common practice to evaluate the performance of drainage materials following Dieleman and Trafford (FAO, 1976). In the procedure that they propose, the discharge is measured together with the total head loss and the head loss 0.40 m away from the drain centre which they consider beyond the boundary of the trench. They define the vertical difference between the latter head and the head at the centre of the drain pipe as 'entrance head loss' and the collected data are used to calculate the entrance resistance and to express the entrance head loss as a fraction of the total head loss. The entrance resistance, which results from such measurements is, in fact, an 'approach flow resistance' and the corresponding head loss is the corresponding 'approach flow head loss' (see Chapter 4, Section *Entrance and approach flow resistance*).

The main reasons why the entrance resistance, defined by Dieleman and Trafford (FAO, 1976), differs from the theoretical entrance resistance are:

- the head loss for the approach flow ( $h_{ap}$ ) and the head loss for the entrance flow ( $h_e$ ) are different (see Chapter 4, Section *Entrance and approach flow resistance*);
- the piezometer for measuring the entrance head loss is not placed at the drain/soil interface, but at some distance from it;
- the flow pattern around the drain is not fully radial, even if water is standing above the drain; and
- water enters the drain through a sector of the drain circumference only.

The approach flow resistance,  $W_{ap}$ , obtained from field experiments should be a constant. There are, however, so many associated factors that it is quite a difficult parameter to evaluate. Factors that affect the approach flow resistance are:

- soil heterogeneity, and heterogeneously distributed hydraulic conductivity;
- heterogeneously distributed drain inflow, even with uniform water supply;
- heterogeneous supply of water due to local irrigation gifts; and
- the variability of head loss along the drains.

Dieleman and Trafford (FAO, 1976) made classes for the 'approach flow head loss fraction' (Table 11) and the 'approach flow resistance' or 'approach flow head loss' (Table 12).

**TABLE 11**  
**Classification according to the 'approach flow head loss fraction'** (after Dieleman and Trafford, FAO, 1976)

Approach flow head loss fraction $h_{ap}/h_t$	Drain line performance
smaller than 0.2	good
0.2 - 0.4	moderate
0.4 - 0.6	poor
larger than 0.6	very poor

**TABLE 12**  
**Classification according to 'approach flow resistance' or 'approach flow head loss'** (after Dieleman and Trafford, FAO, 1976)

Approach flow resistance $W_{ap}$ (d/m)	Approach flow head loss $h_{ap}$ (m)	Drain line performance
smaller than 0.75	smaller than 0.15	good
0.75 - 1.50	0.15 - 0.30	moderate
1.50 - 2.25	0.30 - 0.45	poor
larger than 2.25	larger than 0.45	very poor

It should be kept in mind that the classes in both tables are valid for the conditions they have been drafted for (drain depth of 1.8 m; drain spacing of 50 m; water table depth of 1.0 m one or two days after irrigation and a discharge rate of 4 mm/d at that water table depth). For other conditions, another appreciation should be given to the obtained values (Dierickx, 1996b). Therefore, any attempt to compare approach flow resistances emerging from different field experiments is meaningless unless all conditions of the experimental fields are the same and are well documented.

In addition, the following general recommendations for field research projects must also be taken into account (Ritzema, 1997):

- Make sufficient arrangements for site-office requirements and for resources (human resources, laboratory, and computer facilities).
- Arrange to safeguard unlimited accessibility of the pilot area, at all times.
- Make agreements with farmers, which should be actively involved in the project.
- Provide regular maintenance of the monitoring network, in a separate project.
- Provide data storage facilities in conformity with database tools and software that are locally available and used.
- Process and interpret the data immediately and continuously in order to detect data and/or testing inconsistencies.
- Utilize data presentation techniques (like graphs or summarizing tables) for unambiguous interpretation of results.
- Formulate proposals for a follow-up for the project, reformulating objectives, possibly deciding to discontinue the investigations, or adjustment of the research programme in a subsequent project.

#### RECOMMENDATIONS FOR FUTURE RESEARCH

Theoretical studies, laboratory and field research have all contributed to a gradual increase of knowledge on drainage materials and their performance. The complexity of the physical properties of the soil is, however, the reason that some problems are not yet adequately solved. These problems are only slightly related to drainage materials. Rather, they are associated with soil type, soil condition at the moment of installation and accuracy of installation. This implies that the resulting drain line performance is, to some extent, unpredictable. This is the more so in 'new' areas, where systematic investigations are few or missing. In these regions there is scope for 'reconnaissance-type' of investigations. The best approach would be a search for fields with poorly functioning or failing drains, followed by investigations into the causes and mechanisms of the failures.

Experience gained in the Netherlands in the 1960s may serve as an illustration. A great number of field experiments were carried out by various agencies to test and compare different drainage materials, with the emphasis on entrance resistance. In the light of the researchers' expectations, the results were often disappointing or outright frustrating. The measured data generally showed a wide variation, and rarely reflected a significant difference between the investigated drainage materials. Plotted data often yielded scatter diagrams that resembled, in the words of one researcher, a 'cloudless sky by night'. Really poor functioning, let alone outright failures, hardly were found in the experiments. Thus the conclusion might have been that there was no real reason to worry about entrance resistances or, consequently, about materials at all. On the other hand, drainage failures did turn up in scattered places, but no clear relation with

materials could be established. In large projects, a few percent of failures form an awful heap of complaints, which usually make their way to the director's desk.

A good deal of insight was acquired from a reconnaissance campaign, specifically implemented to track down fields with poorly functioning or (preferably) failing drains. Cavelaars (1967) discusses the results of investigations on 64 fields. The search for failures was difficult because those, responsible for the drain installation (contractors and/or supervising agencies), were not very keen to come up with failures of their work. The subsequent steps consisted of diagnostic field investigations as referred to above; to find out, as accurately as possible, the method of drain installation and the conditions under which this had been done.

## **Drain pipes**

### ***Flow into drains***

The calculation of the discharge capacity of drainpipes requires knowledge of their roughness coefficients. Roughness coefficients have been determined experimentally of all kinds of perforated and unperforated drainpipes, be it full flowing pipes or not. The discharge capacity can be calculated according to two principles: the transport principle and the drainage principle. The drainage principle, with a constant inflow per unit drain length and a gradually increasing discharge, corresponds more accurately with the situation in the field than the transport principle whereby the pipe is assumed to have a constant discharge over its entire length (see Chapter 4, Section *Discharge capacity of drainpipes*).

Still, reality is likely to be different from the theoretical concept of a constant inflow per unit drain length, because of the heterogeneity in flow pattern and in mineral clogging. The main water conveying features are inter-aggregate voids, macropores made by worms and plant roots, and thin, relatively permeable horizontal soil layers (Stuyt, 1992a, 1992c). The accuracy of the grade line of laterals may also affect the uniformity of water inflow. The concept of a constant inflow flow per unit drain length needs further research. It is an important issue since this concept is not only used for design purposes but also to evaluate performances of drainage materials in the field.

### ***Safety factor for design***

Sedimentation and irregularities in alignment may reduce the discharge capacity of drainpipes up to 50 percent (El Atfy *et al.*, 1990). The hydraulic properties of drainpipes are well known, but the accuracy of laying, and future pipe sedimentation necessitate the introduction of a reduction coefficient or a safety factor. The question is to what extent such a safety factor is justified, taking into account the modern installation techniques and the use of reliable and well-designed drainage materials.

## **Drain envelopes**

### ***Soil influx into drains***

X-ray analyses of wrapped drain samples, made by Stuyt (1992a, 1992b, 1992c), revealed that water flow patterns near drains in fine sandy, weakly-cohesive soils, as well as mineral clogging of envelopes are often quite heterogeneous. These findings emphasize the discrepancy between theory and practice, as far as the analysis of water flow near and into drains is concerned. The consequence is that it is presumably quite difficult to accurately measure the entrance head loss

near drains in a pilot area. Drain envelopes may affect the performance of a drainage system, but the effect of soil properties on water acceptance of drains often dominates. This conclusion of the field research of Stuyt (1992a, 1992b, 1992c), together with all other existing information from laboratory research and field experiments indeed limits the necessity of further research on drainage envelopes. As long as chemical and/or microbiological clogging (especially ochre formation) are unlikely to occur, the proposed design criteria can be applied successfully.

Soil influx recognised by Stuyt (1992a) as ‘mushroom’-shaped soil patterns near perforations has also been mentioned by Van der Molen in an experimental drain in the Wieringermeerpolder in The Netherlands (personal communication) and elsewhere by Dierickx (1986a) and Van der Louw (1986). Both Dierickx and Van der Louw used a drain endoscope, while Stuyt used a miniature video camera. Van der Louw and Stuyt assume that ‘mushroom’-formation is the result of soil being squeezed through drain envelopes and pipe perforations. Only one week after jetting drains, Van der Louw found ‘fresh mushrooms’ inside drains, supposedly due to squeezing of liquid soil by the overburden. Yet, a one-by-one particle accumulation during a substantial period (months at least) may be another valid explanation for this phenomenon. This kind of soil influx and its influence on the water acceptance of the drainage system needs further investigation.

#### ***Chemical and/or biochemical clogging***

In case of chemical and/or biochemical clogging, further research may be necessary about the interaction between envelope, soil, and clogging agent. Such research cannot be done in a laboratory. Sophisticated and expensive equipment is required to investigate and to quantify these clogging phenomena. The processes associated with this kind of clogging, however, will continue, regardless of whether an envelope is installed or not. In such cases, some design measures may be considered. If an envelope is required, a voluminous (i.e. with a thickness greater than 5 mm), coarse-structured synthetic envelope is recommended. Regular maintenance of drain lines is often, but not always necessary. It would therefore be useful to quantify the adequacy of such measures, and especially the suitability of voluminous, coarse structured synthetic envelopes, as compared to other types.

#### ***Clogging by substances, related to calcium***

Ochre formation is a frequently occurring phenomenon that has received much attention. Less known, however, is the precipitation in envelopes of calcium carbonate ( $\text{CaCO}_3$ ) or gypsum ( $\text{CaSO}_4 \cdot 2\text{H}_2\text{O}$ ). There is ample scope for systematic investigation on lime and gypsum depositions with pipe drains. It would include an inventory of the extent of the problem and the conditions under which it is likely to develop.

#### ***Laboratory testing of locally made PLMs and geotextiles***

In many countries where gravel envelopes are used by convention, there is a pronounced hesitation to apply synthetic alternatives to conventional envelopes, mainly due to a lack of experience. This concerns mainly imported geotextiles. In many cases, similar products are locally available; if competitive, they should be seriously considered as envelopes. Waste fibres from the carpet industry, original or modified carpet backings and other locally produced geotextiles may be suitable for envelope application. If no experience with such kind of materials exists, applied research with permeameters should be seriously considered. This kind of evaluation does not

contribute to the basic knowledge of the interaction between soil and envelope, but can be quite useful to:

- overcome resistance and hesitation against the use of these newly proposed materials;
- assess the suitability of these materials;
- evaluate their performance as compared to conventional or imported envelopes; and
- make a pre-selection of potentially suitable products for subsequent field evaluation.

### **Soil properties**

#### ***Applicability of the hydraulic failure gradient***

In many cases, the need for envelopes is not yet accurately predictable. With the exception of some specific problem soils, unequivocal guidelines for the necessity of envelopes cannot be specified yet. Differences in the performance of various envelope materials that have distinct parameters are not easy to assess. Only some trends are recognized. Permeameter tests can also be performed to ascertain the need of drain envelopes for a particular soil, if soil characteristics do not give a decisive answer. In this respect, the concept of the hydraulic failure gradient,  $i_f$ , (see Chapter 4, Section *Hydraulic failure gradient*) introduced by Samani and Willardson (1981) requires further consideration. More experience should be gained with the  $i_f$  of a soil, which was proposed as a tool to predict the need for a drain envelope.

#### ***Aggregate stability***

Various methods for determining aggregate stability have been proposed and applied with varying results. Development of a standard technique for application in drainage is required. The effect of soil sodicity on soils around drains seems an intriguing aspect, which needs further investigation.





## Chapter 9

# Standards for pipes and envelopes

Standards on drainpipes specify the required properties of the materials (clay, concrete and plastics) from which the pipes shall be manufactured, and the specifications of these raw materials, e.g. in terms of chemical composition and additives, as well as the standard pipe strengths. For plastic drains, the standards usually specify whether the use of recycled raw materials is permitted, and under which conditions. The physical dimensions are also subject to specification, e.g. the inside and outside diameters, and the size and location of perforations.

The mechanical properties of drainpipes refer to transport, installation, and error-free functioning. Important requirements are crushing strength for clay and concrete tiles, and for plastics the impact strength, brittleness, and pipe stiffness on the short and long term. Flexible pipes may only very slightly deform due to the overburden of the soil if they are properly installed.

The use of antioxidants and UV inhibitors in plastics should be restricted to quantities that do not change the mechanical properties of the pipes. Some specifications, such as ASTM standards, limit the period of outdoor storage to two years; others give no time limit.

In large-scale drainage projects, testing of pipes and envelopes is of interest for engineers, contractors, and supervisors to check whether drainage materials comply with specifications as required in tenders. In particular, this will be the case in countries where drainage materials are not supplied with official certificates that guarantee compliance with certain standards.

Existing standards for drainage materials originating from countries with a long drainage history are useful to countries that are virtually without any drainage experience. They can be used as a reference to develop a national standard, which is adapted to specific, local circumstances. However, the number of parameters tested should be limited in order to keep the cost of testing within reasonable limits.

The use of sophisticated testing equipment is not always necessary; simple tools can be applied instead. Occasionally, simple rules of thumb can be applied, like striking a clay tile with a metal object: a good quality tile will then give a clear 'ring sound'. Another simple procedure would be to try to crush a 50-mm corrugated PVC pipe by simply loading it with a specified weight. Testing for cold brittleness can be done by a hammer after putting a section of pipe in a refrigerator for 12 hours.

Continuous quality control during manufacture is indispensable to keep inferior quality pipes and unreliable envelope materials off the market. Many countries, where a substantial number of subsurface drainage projects are carried out, have their own national standards or specifications for drainage materials. They have been developed by standardization committees, consisting of specialists from governmental research institutes and private companies. Standards were drafted for clay and concrete pipes, followed by standards for smooth and corrugated plastic pipes. The use of drain envelope materials resulted in the simultaneous development of standards for envelopes.

Instead of publishing an incomplete list of the numerous existing national standards with their various aspects, only the standards of the American Society of Testing Materials (ASTM), some Canadian standards, the draft standard of the International Organisation for Standardisation (ISO) and the draft EN-standard of the European Committee for Standardisation (CEN – Comité Européen de Normalisation) will be referenced. Although the draft ISO and EN-standards cannot be legally imposed, they are the result of discussions between experts from many countries and organizations.

For more details, reference is made to the standards themselves or to the Annex that contains the draft EN-standard on corrugated plastic piping systems. This standard is not yet published and hence not readily available. The draft ISO-standard has not been included in this Annex, since it contains the fundamentals and the concepts on the basis of which the EN standard was developed.

#### **TESTING PARAMETERS FOR DRAINPIPES**

For drainpipes the inside and outside diameter are specified with their tolerances. Moreover the following parameters are usually included in standards:

##### **Clay and concrete pipes**

- ovality and curvature;
- verticality of the end planes;
- resistance to weathering and deterioration in soil;
- resistance to freezing and thawing cycles;
- density;
- water absorption; and
- crushing strength.

##### **Concrete pipes**

In addition to the above:

- sulphate resistance; and
- acid resistance.

##### **Plastic pipes**

- stiffness and elongation resistance;
- impact strength and brittleness;
- flexibility and coilability;
- perforations and hydraulic properties; and
- handling and installation instructions.

The substitution of clay and concrete pipes by corrugated plastic pipes made standards for clay and concrete pipes less important although they are still useful in countries where clay and concrete pipes are still installed, including larger diameter collector drains.

**TESTING PARAMETERS FOR ENVELOPES**

Requirements for drain envelope materials include the following parameters:

**Granular materials**

- granulometry or particle size distribution;
- permeability; and
- chemical composition.

**PLMs and geotextiles**

- appearance;
- thickness and mass per unit area; and
- pore size.

**Geotextiles**

In addition to the above:

- permeability; and
- watability.

**NORTH AMERICAN STANDARDS**

In the United States, specifications for clay pipes include three classes, namely *standard*, *extra quality*, and *heavy duty*; for concrete pipes a fourth class, namely *special duty*, has been added. Standard-quality pipes are satisfactory for drains of moderate sizes and installation depths. There is a family of ASTM-standards for clay and concrete pipes. The latest version of the relevant standards is given in Table 13.

**TABLE 13**  
**ASTM-standards for clay and concrete drainpipes**

<b>Material and type</b>	<b>Standard</b>
Clay drain tile and perforated drain tile	ASTM C4-99 <sup>1</sup>
Clay drain tile, perforated	ASTM C498-95
Clay pipe, vitrified, perforated	ASTM C700-99
Concrete drain tile	ASTM C412M-99
Concrete pipe, perforated	ASTM C444-95
Concrete pipe for irrigation or drainage	ASTM C118M-99
Reinforced culvert, storm drain, and sewer pipe	ASTM C76-99
Concrete sewer, storm drain, and culvert pipe	ASTM C14M-99

<sup>1</sup> The last two digits give the year of publication of the latest version while M indicates that the standard is in SI (metric) units

Shortly after corrugated plastic pipes were first installed in the United States, the need for standards was recognized and ASTM adopted the first standard in 1974 for corrugated PE pipes and fittings (see ASTM F405-97). In 1976, a standard for large diameter pipes (see ASTM F667-97) was added, and in 1983, a standard for PVC pipes (ASTM F800-83) was adopted, yet standardization work on PVC pipes was discontinued in 1992. Since 1972, over 30 ASTM standards have been developed for corrugated plastic pipes. A partial list of ASTM and other standards in Canada and the United States is given in Table 14.

**TABLE 14**  
**United States and Canadian standards for corrugated plastic pipes**

Material and type	Nominal inside diameter (mm)	Standard
Plastic pipes, drainage	75-300	CGSB <sup>1</sup> 41-GP-29Ma (1983)
Plastic pipes and fittings	100-300	BNQ <sup>2</sup> 3624-115 (1985)
Polyethylene pipes and fittings	75-150	ASTM F405-97
Polyethylene pipes	200-300	ASTM F667-97
Polyethylene pipes	100-200	USBR <sup>3</sup> (1974)
Polyethylene and polyvinyl chloride pipes	250-300	USBR <sup>3</sup> (1981)
Polyvinyl chloride pipes and fittings	100-200	ASTM <sup>4</sup> F800-83
Polyvinyl chloride pipes	100-200	USBR <sup>3</sup> (1976)
Polyvinyl chloride pipes	75-300	SCS <sup>5</sup> 606 (1980)

<sup>1</sup> Canadian General Standard Board

<sup>2</sup> Bureau de Normalisation du Quebec

<sup>3</sup> US Bureau of Reclamation (1993)

<sup>4</sup> Revision discontinued in 1992

<sup>5</sup> USDA Soil Conservation Service, presently: National Resource Conservation Service (NRCS, 1998)

#### EUROPEAN STANDARDS

In 1973, the International Standard Organisation (ISO) began to prepare an international standard on 'Pipes and fittings of unplasticized polyvinyl chloride (PVC-U) for sub-soil drainage specification'. In 1985, the draft version was published (Schultz, 1990), and the work discontinued. To date, no final version has been drafted.

Within the European Union, technical specifications are established, in principle within Comité Européen de Normalisation (CEN). Through the creation of this CEN committee, all national standardization work in the participating countries on issues that are subject of European standardization had to be discontinued. This almost ended standardization work by the member states. All European and European Free Trade Association (EFTA) countries can now participate in the co-ordination and harmonization of standards. ISO-representatives may participate as observers in the CEN/TC meetings. Wherever possible, decisions are made by consensus. European Standards are mandatory for all public procurement projects within the European Union.

In 1990, Working Group 18 (WG18) for land drainage, created within the Technical Committee 155 (TC155) of CEN was in charge of 'Plastic piping systems and ducting systems'. CEN/TC155/WG18 (1994) prepared a first draft of the European (EN) standard 'Plastics Piping Systems for Agricultural Land Drainage (PVC-U)'<sup>1</sup>. Although the draft has already passed the CEN-enquiry stage, no further progress has been made since then and, like the ISO standardization work on corrugated pipes, it came to a standstill. In spite of this, the draft standard contains useful information, which includes general functional requirements for *pipes*, *fittings* and *envelopes*, as well as a recommended practice for installation.

In 1989, CEN/TC189 was established to agree on common testing procedures, methods of identification and assessment techniques for *geotextiles*. TC189 is working on a family of relevant test procedures for geotextiles and geotextile related products that will be common to all participating countries. The presentation of index values in all countries will be based on the same test methods but the requirements will be left to the responsibility of the individual countries. In practice, nearly all geotextiles will be produced and sold according to EN-standards. Relevant EN-standards for geotextiles used as drainage envelopes are given in Table 15.

<sup>1</sup> Unplasticized polyvinyl chloride.

**TABLE 15**  
**European (EN) standard for geotextiles and geotextile-related products which can be useful when used as envelopes in agricultural drainage**

Title	Standard	Issued
Identification on site	EN ISO 10 320 <sup>1</sup>	1999
Sampling and preparation of test specimen	EN 963	1995
Determination of the thickness – single layers	EN 964-1	1995
Mass per unit area	EN 965	1995
Geotextiles : vocabulary	pr EN 30 318 <sup>2</sup>	1998
Tensile test for joints/seams by wide-width test method	EN ISO 10 321	1996
Method of simulating abrasion damage (sliding block)	EN ISO 13 427	1998
Static puncture test	EN ISO 12 236	1996
Wide-width tensile test	EN ISO 10 319	1996
Water permeability	EN ISO 11 058	1999
Opening size	EN ISO 12 956	1999
Water flow capacity in the plane	EN ISO 12 958	1999
Water penetration resistance	pr EN 13 562	1999
Water permeability under load	CEN/TC189/WI26 <sup>3</sup>	1999
Resistance to weathering	ENV 12 224 <sup>4</sup>	1996
Resistance to microbiological degradation	ENV 12 225	1996
General tests for evaluation following durability testing	ENV 12 226	1996
Resistance to hydrolysis	ENV 12 447	1997
Resistance to liquids	ENV ISO 12 960 <sup>1</sup>	1998

<sup>1</sup> EN ISO or ENV ISO is both an EN (or an ENV) and an ISO standard

<sup>2</sup> prEN is a draft standard which is not yet finalized

<sup>3</sup> Work item 26 of CEN/TC 189 under discussion

<sup>4</sup> ENV is a pre-standard, established as a prospective standard for provisional application (validity period of 2 years)

The draft EN-standard for corrugated PVC pipes for land drainage also deals with drainage envelopes; it includes geotextiles and PLMs. This part of the draft standard reflects the kind of drainage envelope materials that are used in the European Union. Furthermore, information is given on the evaluation process (equipment, measurement procedure, accuracy, etc.). The specifications are based on consensus and do not necessarily correspond with those of a particular country, although the influence of experienced countries may be obvious.



## References

- Abdel-Dayem, M.S. 1987. Development of land drainage in Egypt. In: Proc. Symp. 25<sup>th</sup> International Course on Land Drainage. Twenty-Five Years of Drainage Experience. J. Vos (ed.). *Publ. 42*, ILRI, Wageningen, The Netherlands, pp. 195-204.
- Abdel-Dayem, M.S., Ritzema, H.P., El-Atfy, H.E. and Amer, M.H. 1989. Pilot areas and drainage technology. In: *Land Drainage in Egypt*. M.H. Amer and N.A. de Ridder (eds.). DRI, Cairo, pp. 103-161.
- Ami, S. R. 1987. *Drainage Pipe Testing Manual*. Canadian International Development Agency (CIDA), Hull, Quebec, Canada.
- Antheunisse, J. 1979. Observations on the decomposition of coconut fibres. *J. Gen. Appl. Microbiol.* **25**: 273-277.
- Antheunisse, J. 1980. The breakdown of coconut fibres by *Trametes Versicolor* and *Stereum Rugosum*. *J. Gen. Appl. Microbiol.* **26**: 167-170.
- Antheunisse, J. 1981. Decay of coconut fibres by soil microorganisms. *J. Gen. Appl. Microbiol.* **27**: 435-442.
- Antheunisse, J. 1983. Biological and chemical inhibition of ligno-cellulose decay by white rot basidiomycetes. *J. Gen. Appl. Microbiol.* **29**: 257-269.
- Antheunisse, J. 1984. Biological and chemical inhibition of coir decomposition under imitated field conditions. *J. Gen. Appl. Microbiol.* **30**: 245-248.
- ASTM C4-99. 1999. *Standard Specification for Clay Drain Tile and Perforated Clay Drain Tile*. ASTM, West Conshohocken, PA, United States.
- ASTM C14M-99. 1999. *Standard Specification for Concrete Sewer, Storm Drain, and Culvert Pipe*. ASTM, West Conshohocken, PA, United States.
- ASTM C76-99. 1999. *Standard Specification for Reinforced Culvert, Storm Drain, and Sewer Pipe*. ASTM, West Conshohocken, PA, United States.
- ASTM C118M-99. 1999. *Standard Specification for Concrete Pipe for Irrigation or Drainage*. ASTM, West Conshohocken, PA, United States.
- ASTM C412M-99. 1999. *Standard Specification for Concrete Drain Tile*. ASTM, West Conshohocken, PA, United States.
- ASTM C444M-95. 1995. *Standard Specification for Perforated Concrete Pipe*. ASTM, West Conshohocken, PA, United States.
- ASTM C498-95. 1995. *Specification for Perforated Clay Drain Tile*. ASTM, West Conshohocken, PA, United States.
- ASTM C700-99. 1999. *Specification for Vitrified Clay Pipe, Extra Strength, Standard Strength, and Perforated*. ASTM, West Conshohocken, PA, United States.
- ASTM D5101-96. 1996. *Standard Test Method for Measuring the Soil-geotextile System Clogging Potential by the Gradient Ratio*. ASTM, West Conshohocken, PA, United States.
- ASTM F405-97. 1997. (superseded ASTM 405-74, 1974). *Standard Specification for Corrugated Polyethylene (PE) Tubing and Fittings*. ASTM, West Conshohocken, PA, United States.

- ASTM F667-97. 1997. (superseded ASTM F667-76, 1976). *Standard Specification for Large Diameter Corrugated Polyethylene Pipe and Fittings*. ASTM, West Conshohocken, PA, United States.
- ASTM F800-83. 1983. *Specification for Corrugated Polyvinyl Chloride (PVC) Tubing and Fittings*. ASTM, West Conshohocken, PA, United States.
- Ayers, R.S. and Westcot, D.W. 1985. Water quality for agriculture. *FAO Irrigation and Drainage Paper 29 (Rev. 1)*. Rome.
- Bertram, G.E. 1940. An experimental investigation of protective filters. *Harvard Soil Mechanics Series 7*. Pierce Hall Harvard University.
- Blom, E. 1987. Omhullingsmaterialen voor drainbuizen: veldonderzoek naar inspoeling en vertering [Envelope materials for drain pipes: field investigation into pipe sedimentation and envelope decomposition]. *Report of the Government Service of Land and Water Use*, Goes, The Netherlands.
- BNQ 3624-115. 1985. *Tubes annelés et raccords de thermoplastique pour drainage des sols* [Corrugated Thermoplastic Pipes and Fittings for Land Drainage]. Bureau de Normalisation de Québec. Ministère de l'Industrie et du Commerce, Canada.
- Bons, A. and Van Zeijts, T.E.J. 1991. Jet flushing, a method for cleaning subsurface drainage systems. *Information Paper 28*, Government Service for Land and Water Use, Utrecht, The Netherlands.
- Boumans, J.H. 1963. Over instroming en aanstroming bij draineerbuizen zonder en met afdekking [On flow into and towards drainpipes with and without cover sheet]. *Cultuurtechnisch Tijdschrift*, **2**: 218-229.
- Boumans, J.H. 1988. Stromingsformules voor drainage ribbelbuis (Flow formulae for corrugated drainpipes). *Tijdschrift voor Cultuurtechniek* **1**: 41-46.
- Brinkhorst, W., van der Linde K. and Scholten, J. 1983. Ervaringen met het doorspuiten van drains in het Lauwersmeergebied [Experiences with jetting of pipe drains in the Lauwersmeer area]. *Report 6 abw*, R.I.J.P., Lelystad, The Netherlands.
- Busser, J.W. and Scholten, J. 1979. Drainage maintenance in The Netherlands. In: Proc. Internat. Drain. Workshop. J. Wesseling (ed.). *Publ. 25*, ILRI, Wageningen, The Netherlands, pp. 424-438.
- Cavalaars, J.C. 1966. *Hydrological Aspects of the Application of Plastic Drain Pipes and Filter Materials*. Koninklijke Nederlandsche Heidemaatschappij, Arnhem, The Netherlands.
- Cavalaars, J.C. 1967. Problems of water entry into plastic and other drain tubes. Proc. Agr. Eng. Symp. *A.E.S. Paper 5/E/46*, Nat. Coll. of Agr. Eng., Silsoe, United Kingdom.
- Cavalaars, J.C. 1970. *Toestromingsweerstand bij buisdrainage* [Approach Flow Resistance near Drainpipes]. Kon. Ned. Heidem., Afdeling Onderzoek, Arnhem, The Netherlands.
- Cavalaars, J. 1974. Subsurface field drainage systems. In: Drainage Principles and Applications. Design and Management of Drainage Systems. *Publ. 16, Vol. IV*, ILRI, Wageningen, The Netherlands, pp. 1-65.
- Cavalaars, J.C. 1979. Composing a drainage pipe line out of sections with different diameters. In: Proc. Internat. Drain. Workshop. J. Wesseling (ed.), *Publ. 25*, ILRI, Wageningen, The Netherlands, pp. 402-423.
- Cavalaars, J.C. 1987. Comment made during discussion in session 4 in ILRI Symposium. In: Proc. Symp. 25<sup>th</sup> Internat. Course on Land Drainage. Twenty-Five Years of Drainage Experience. J. Vos (ed.). *Publ. 42*, ILRI, Wageningen, The Netherlands.
- Cavalaars, J.C., Vlotman, W.F. and Spoor, G. 1994. Subsurface drainage systems. In: Drainage Principles and Applications. H.P. Ritzema (ed.). *Publ. 16, 2<sup>nd</sup> ed.* (completely revised), ILRI, Wageningen, The Netherlands, pp. 827-929.
- CEMAGREF. 1983. Le colmatage des drains agricoles: Etat des connaissances en France en 1983 [Clogging of Agricultural Drains: Current Knowledge in France in 1983]. *Information Techniques 51-5*, CEMAGREF, Groupement d'Antony, France.



- CEN/TC155/WG18. 1994. *Plastics Piping Systems for Agricultural Land Drainage (PVC-U)*. CEN, Brussels.
- CEN/TC189/WI26. 1999. *Geotextiles and Geotextile-related Products - Determination of Water Permeability Characteristics Normal to the Plane, with Load*. CEN, Brussels.
- Cestre, T. and Houot, S. 1984. Nettoyage sous pression de deux réseaux de drainage agricole. Efficacité d'un matériel sur différents types de colmatage [Jetting of Drains at Two Sites. Efficiency for Different Types of Clogging]. *Bulletin 313*, CEMAGREF, Groupement d'Antony, France.
- CGSB 41-GP-29Ma. 1983. *Corrugated Plastic Drainage Tubing*. Canadian General Standard Board, Department of Supply and Services, Ottawa, Ontario, Canada.
- Chapman, D. 1956. Ditches, dykes and deep-drainage. *Young Farmer's Club Booklet 29*. Evans Brothers LTD, London.
- Childs, E.C. and Youngs, E.G. 1958. The nature of the drain channel as a factor in the design of a land-drainage system. *Journ. Soil Sci.* **9**, **2**: 316-331.
- Chin, Y.M., Nikraz, H.R. and Press, M. 1994. Laboratory filtration performance of nonwoven geotextiles. In: *Proc. 5<sup>th</sup> Internat. Conf. on Geotextiles, Geomembranes and Related Products*. G.P. Karunaratne, S.H. Chew & K.S. Wong (eds.). Singapore, **Vol. 2**: 635-638.
- CPVQ. 1989. Drainage souterrain [Subsurface drainage]. *Agdex 555*. Cahier des normes. Conseil des Productions Végétales du Québec - Vegetal Production Board of Quebec. Ministère de l'Agriculture et de l'Alimentation du Québec, Canada.
- De la Torre, A.A. 1987. Drainage and land reclamation in Peru. In: *Proc. Symp. 25<sup>th</sup> Internat. Course on Land Drainage. Twenty-Five Years of Drainage Experience*. J. Vos (ed.). *Publ. 42*, ILRI, Wageningen, The Netherlands, pp. 268-277.
- Dennis, C.W. and Trafford, B.D. 1975. The effect of permeable surrounds on the performance of clay field drainage pipes. *J. of Hydrol.* **24**: 239-249.
- Desmond, E.D. and Schwab, G.O. 1986. Ultraviolet degradation of corrugated plastic tubing. *Transactions of the ASAE* **29**, **2**: 467-472.
- Dieleman, P.J. and Trafford, B.D. 1976. Drainage testing. *FAO Irrigation and Drainage Paper 28*. Rome.
- Dierickx, W. 1980. Electrolytic analogue study of the effect of openings and surrounds of various permeabilities on the performance of field drainage pipes. *Report 77*, Comm. of the Nat. Inst. for Agr. Eng., Merelbeke, Belgium.
- Dierickx, W. 1986a. Soil invasion into drain pipes. In: *Agricultural Water Management, Proc. Symp. on Agric. Water Management*. A.L.M. Van Wijk and J. Wesseling (eds.). A.A. Balkema, Rotterdam, The Netherlands, pp 151-161.
- Dierickx, W. 1986b. Field experience and laboratory research on drainage envelopes. In: *Proc. of Internat. Seminar on Land Drainage*. J. Saavalainen and P. Vakkilainen (eds.). Helsinki University of Technology, Finland, pp. 51-60.
- Dierickx, W. 1987. Choice of subsurface drainage materials. *ASAE-paper 87-2589, 1987*. Winter Meeting of the ASAE. Chicago, IL, United States.
- Dierickx, W. 1988. *Drainage Envelope Research*. Pilot Areas and Drainage Technology Project. Drainage Research Institute, El-Kanater, Cairo.
- Dierickx, W. 1990. *Onderzoek naar een slibvang voor de jachthaven van Antwerpen* [Research on a Sediment Trap for the Yacht-basin of Antwerp]. Internal Report. Research Station for Agricultural Engineering, Merelbeke, Belgium.
- Dierickx, W. 1991. Laboratory and field research on subsurface drainage envelopes in Pakistan. *Report 90/08*. International Waterlogging and Salinity Research Institute (IWASRI), Lahore, Pakistan.

- Dierickx, W. 1992a. *Research on Synthetic Envelopes for Subsurface Drainage in Egypt*. Pilot Areas and Drainage Technology Project. Drainage Research Institute, El-Kanater, Cairo.
- Dierickx, W. 1992b. Use of drainage materials - research on developments in selecting drainage materials. In: *Proc. 5<sup>th</sup> Internat. Drainage Workshop*. W.F. Vlotman (ed.). Lahore, Pakistan, **Vol. I**, pp. 95-115.
- Dierickx, W. 1993. Research and developments in selecting subsurface drainage materials. *Irrigation and Drainage Systems* **6**: 291-310.
- Dierickx, W. 1994. *Data Analysis of Laboratory and Field Research on Synthetic Envelopes for Pipe Drainage*. IWASRI, Lahore, Pakistan.
- Dierickx, W. 1996a. Determination of water penetration resistance of geotextiles. In: *Proc. Symposium on Recent Developments in Geotextile Filters and Prefabricated Drainage Geocomposites*. S.K.Bhatia and L.D. Suits (eds.), *ASTM STP 1281*, pp. 65-74.
- Dierickx, W. 1996b. Field research on drainage envelope materials. *Internal Report 96/5*, IWASRI, Lahore, Pakistan.
- Dierickx, W. 1998a. Changes in specific properties of PVC drains under various storage conditions. *Agric. Water Manage.* **37, 2**: 109-119.
- Dierickx, W. 1998b. Unpublished research results on weathering of loose polypropylene fibre wrappings for drain pipes. Research Station for Agricultural Engineering, Merelbeke, Belgium.
- Dierickx, W. 1998c. *Training Course on Drainage Envelope Research*. CSSRI, Karnal, India. ILRI, Wageningen, The Netherlands.
- Dierickx, W. 1999. Non-ideal drains. In: *Agricultural Drainage*. R.W. Skaggs and J. Van Schilfgaarde (eds.). *Agron. Monogr. 38*. ASA, CSSA, and SSSA, Madison, WI, United States, pp. 297-330.
- Dierickx, W. and Leyman, N. 1991. *Drainage van landbouwgronden: theorie, criteria, materialen* [Drainage of Agricultural Soils: Theory, Criteria, Materials]. Ministerie Van de Vlaamse Gemeenschap, Bestuur Landinrichting en -beheer, Vlaamse Landmaatschappij, Belgium.
- Dierickx, W. and Van der Sluys, L. 1990. Research into the functional hydraulic properties of geotextiles. In: *Proc. 4<sup>th</sup> Internat. Conf. on Geotextiles, Geomembranes and Related Products*. G. den Hoedt (ed.). A.A. Balkema, Rotterdam. The Hague, The Netherlands. **Vol. 1**, pp. 285-288.
- Dierickx, W. and Yüncüoğlu, H. 1982. Factors affecting the performance of drainage envelope materials in structural unstable soils. *Agric. Water Manage.* **5**: 215-225.
- Dierickx, W., Bhutta, M.N., Shafiq-ur-Rehman and Rafiq, W. 1995. Laboratory evaluation of synthetic drain envelopes. *Publication 145*, IWASRI, Lahore, Pakistan.
- Dierickx, W., Lennoz-Gratin, C. and Stuyt, L.C.P.M. 1987. Joint European research into land drainage envelopes. In: *Drainage design and management. Proc. of the 5<sup>th</sup> Nat. Drainage Symp.* ASAE, St. Joseph, MI, United States, pp. 406-415.
- DRI, 1997. Practical experiences with trenchless drainage (V-plow) in Egypt. *Technical Report 92*. DRI, Cairo/ILRI, Wageningen, The Netherlands/Euroconsult, Arnhem, The Netherlands.
- Eggelsmann, R. 1978. *Subsurface Drainage Instructions*. Paul Parey, Hamburg, Germany.
- Eggelsmann, R. 1982. Two decades of experience with drainage filters in the Federal Republic of Germany. In: *Advances in Drainage. Proceedings 4<sup>th</sup> Nat. Drainage Symp.* ASAE, St. Joseph, MI, United States, pp. 115-120.
- El Atfy, H., Wahid El Din, O., El Gamaal, H. and Ritzema, H.P. 1990. Hydraulic performance of subsurface collector drains in Egypt. In: *Symp. on Land Drainage for Salinity Control in Arid and Semi-Arid Regions*, Cairo, **Vol. 3**, pp. 393-405.
- EN 963. 1995. *Geotextiles and Geotextile-related Products - Sampling and Preparation of Test Specimens*. CEN, Brussels.

- EN 964-1. 1995. *Geotextiles and Geotextile-related Products - Determination of Thickness at Specified Pressures-Part 1: Single layers*. CEN, Brussels.
- EN 965. 1995. *Geotextiles and Geotextile-related Products - Determination of Mass per Unit Area*. CEN, Brussels.
- EN ISO 10 319. 1996. *Geotextiles - Wide-width Tensile Test*. CEN, Brussels.
- EN ISO 10 320. 1999. *Geotextiles and Geotextile-related Products - Identification on Site*. CEN, Brussels.
- EN ISO 10 321. 1996. *Geotextiles - Tensile Test for Joints/seams by Wide Width Method*. CEN, Brussels.
- EN ISO 11 058. 1999. *Geotextiles and Geotextile-related Products - Determination of Water Permeability Characteristics Normal to the Plane, without Load*. CEN, Brussels.
- EN ISO 12 236. 1996. *Geotextiles and Geotextile-related Products - Static Puncture Test (CBR-Test)*. CEN, Brussels.
- EN ISO 12 956. 1999. *Geotextiles and Geotextile-related Products - Determination of the Characteristic Opening Size*. CEN, Brussels.
- EN ISO 12 958. 1999. *Geotextiles and Geotextile-related Products - Determination of Water Flow Capacity in their Plane*. CEN, Brussels.
- EN ISO 13 427. 1998. *Geotextiles and Geotextile-related Products - Abrasion Damage Simulation*. CEN, Brussels.
- ENV 12 224. 1996. *Geotextiles and Geotextile-related Products - Determination of Resistance to Weathering*. CEN, Brussels.
- ENV 12 225. 1996. *Geotextiles and Geotextile-related Products - Method for Determining the Microbiological Resistance by a Soil Burial Test*. CEN, Brussels.
- ENV 12 226. 1996. *Geotextiles and Geotextile-related Products - General Tests for Evaluation Following Durability Testing*. CEN, Brussels.
- ENV 12 447. 1997. *Geotextiles and Geotextile-related Products - Screening Test Method for Determining the Resistance to Hydrolysis*. CEN, Brussels.
- ENV ISO 12 960. 1998. *Geotextiles and Geotextile-related Products - Screening Test Method for Determining the Resistance to Liquids*. CEN, Brussels.
- Ernst, L.F. 1954. Het berekenen van stationaire grondwaterstromingen, welke in een vertikaal vlak afgebeeld kunnen worden [The computation of steady state groundwater flows, which can be projected in the vertical plane]. *Rapport IV*. Landbouwproefstation en Bodemk. Inst. T.N.O. Groningen, The Netherlands.
- FAO. 1972. Drainage materials. *FAO Irrigation and Drainage Paper 9*. Rome.
- FAO. 1976. Drainage testing. P.J Dieleman and B.D.Trafford. *FAO Irrigation and Drainage Paper 28*. Rome.
- FAO. 1985. Water quality for agriculture. R.S. Ayers and D.W. Westcot. *FAO Irrigation and Drainage Paper 29 (Rev. 1)*. Rome.
- FAO. 1990. *Guidelines for Soil Profile Description, 3<sup>rd</sup> ed. (revised)*. Soil Resources, Management and Conservation Service, Land and Water Development Division, Rome.
- FAO and ICID. 1997. Management of agricultural drainage water quality. C.A. Madramootoo, W.R. Johnston and L.S. Willardson. 1997. *Water Report 13*. Rome.
- Faure, Y. 1991. Développements récents de la recherche sur les problèmes de filtration par géotextiles [Recent research developments on filtration problems of geotextiles]. In: *Colmatage des drains et enrobages: état des connaissances et perspectives* (Clogging of Drains and Envelopes: State of Knowledge and Perspectives). N. Linard (ed.). CEMAGREF, Groupement d'Antony, France, pp. 83-97.

- Feichtinger, F. 1966. Die Wasseraufnahmefähigkeit der Dränrohre. Ein Vergleich von Ton- und Kunststoffrohrdränen [The water uptake capacity of drain pipes. A comparison between clay and plastic drain pipes]. *Österreichische Wasserwirtschaft* **18**, **11/12**: 247-255.
- Fischer, G.R., Holtz, R.D. and Christopher, B.R. 1994. Filtration behaviour of broadly graded, cohesionless tills. In: *Proc. 5<sup>th</sup> Internat. Conf. on Geotextiles, Geomembranes and Related Products*. G.P. Karunaratne, S.H. Chew and K.S. Wong (eds.). Singapore, **Vol 2**, pp. 659-662.
- Ford, H.W. 1979. Characteristics of slimes and ochre in drainage and irrigation systems. *Transactions ASAE* **22**, **5**:1093-1096.
- Ford, H.W. 1980. The problem of dripper clogging and methods for control. *Proc. Symp. Drip Irrig. in Hort.* Skierniewice, Poland, **1**: 99-105.
- Ford, H.W. 1982a. Biological clogging of drain envelopes. In: *Proc. 2<sup>nd</sup> Internat. Drainage Workshop*, Washington, DC, pp. 215-220.
- Ford, H.W. 1982b. Estimating the potential for ochre clogging before installing drains. *Transactions ASAE* **25**, **6**: 1597-1600.
- Framji, K. K., Garg, B. C. and Kaushish, S. P. (eds.). 1987. *Design Practices for Covered Drains in an Agricultural Land Drainage System*. ICID, New Delhi.
- Heeres, J., Kreeftenberg, H.W. and Nieboer, R.H. 1985. Het doorspuiten van drains onder hoge druk [High pressure cleaning]. *Landbouwmecanisatie* **36-12**. Wageningen, The Netherlands.
- Henkin, E. 1987. Twenty-five years of drainage in Israel. In: *Proc. Symp. 25<sup>th</sup> Internat. Course on Land Drainage. Twenty-Five Years of Drainage Experience*. J. Vos (ed.). *Publ. 42*, ILRI, Wageningen, The Netherlands, pp. 205-215.
- Huinink, J.T.M., 1991. *Drainage proefveld "Staverense Noordermeer"* [Land Drainage Pilot Area "Staverense Noordermeer"]. IKC, Ede, The Netherlands.
- Huinink, J.T.M. 1992. Herziening keuzetabel drainage omhullingsmateriaal [Revision of Selection Criteria for Envelope Materials]. *Landinrichting* **32**, **3**: 31-33.
- ICID, 1996. *Multilingual Technical Dictionary on Irrigation and Drainage*. Revised ed. New Delhi.
- Irwin, R.W. 1982. Hydraulic roughness of corrugated plastic tubing. In: *Proc. 2<sup>nd</sup> Internat. Drainage Workshop*. Washington, DC, pp. 52-62.
- Irwin, R.W. 1984. Corrugated pipe flow rate from pipe geometry. *Journ. Irr. and Drainage Eng.* **2**: 237-241.
- ISO 811. 1981. *Textile Fabrics - Determination of Resistance to Water Penetration - Hydrostatic Pressure Test*. ISO, Geneva, Switzerland.
- ISO 10 318. 1990. *Geotextiles - Vocabulary*. ISO, Geneva, Switzerland.
- ISO/DIS 8771. 1985. *Pipes and Fittings of Unplasticized Polyvinyl Chloride (PVC-U) for Sub-soil Drainage - Specification*. ISO, Geneva, Switzerland.
- IWASRI, 1997. *IWASRI News* **4**, **3**: 2. IWASRI, Lahore, Pakistan.
- Jarman, C.G. and Jayasundera, D.S. 1975. The extraction and processing of coconut fibre. *Report G94*, Tropical Products Institute, Ministry of Overseas Development, London.
- Juusela, T. 1958. On methods of protecting drain pipes and on the use of gravel as a protective material. *Acta Agr. Scand.* **VIII**, **I**: 62-87.
- Kabina, P. and Dierickx, W. 1986. Wirksamkeit ausgewählter Dränfilter aus Fasern in Lehmboden [Performance of selected drain pipe fibre envelopes in a silty soil]. *Z.f. Kulturtechnik und Flurbereinigung* **27**:329-338.
- Karpoff, K.P. 1955. The use of laboratory tests to develop design criteria for protective filters. *Amer. Soc. Test. Mater.* **55** :1183-1198.

- Kessler, J. 1970. Data processing and analysis. In: Deriving soil hydrological constants from field drainage tests. P.J. Dieleman, 1974. *Publ. 16*, Vol. III, ILRI, Wageningen, The Netherlands, pp. 329-350.
- Knops, J.A.C. and Dierickx, W. 1979. Drainage materials. In: Proc. Internat. Drain. Workshop. J. Wesseling (ed.). *Publ. 25*, ILRI, Wageningen, The Netherlands, p. 14-38.
- Knops, J.A.C., Zuidema, F.C., Van Someren, C.L. and Scholten, J. 1979. Guidelines for the selection of envelope materials for subsurface drains. In: Proc. Internat. Drain. Workshop. J. Wesseling (ed.). *Publ. 25*, ILRI, Wageningen, The Netherlands, pp. 439-450.
- Koenigs, F.F.R. 1964. Vochtgehalte bij de bewerking en doorlatendheid van zandgronden [The impact of soil water content and mechanical manipulation on the hydraulic conductivity of sandy soils]. *Tijdschrift Koninklijke Nederlandse Heidemaatschappij* **75**, **12**: 617-627.
- Kruse, E.G. 1962. Design of gravel packs for wells. *Amer. Soc. Agr. Eng., Trans.* **5**, **2**: 197-199.
- Lagacé, R. 1983. *Predicting Drain Silting Potential*. Ph.D.-Thesis, North Carolina State University, Dept. of Biol. and Agric. Eng., Raleigh, NC, United States.
- Lechler GmbH, 1980. Manufacturer of High Pressure Drain Jetting Equipment. P.O. Box 1709, D-7012 Fellbach, Germany.
- Lennoz-Gratin, C. 1987. The use of geotextiles as drain envelopes in France in connection with mineral clogging risks. *Geotextiles and Geomembranes* **5**, **2**: 71-89.
- Lennoz-Gratin, C. 1992. Envelopes to prevent pipe mineral clogging of subsurface drainage systems: a review of French standards. In: *Proc. 5<sup>th</sup> Internat. Drainage Workshop*. W.F. Vlotman (ed.). Lahore, Pakistan, Vol. III, pp. 5.18-5.25.
- Lennoz-Gratin, C. and Zaïdi, K. 1987. *Hydraulique au voisinage du drain* [Hydraulics in Drain Vicinity]. Série Hydraulique Agricole. CEMAGREF, Groupement d'Antony, France, **2**: 1-139.
- Lennoz-Gratin, C., Lesaffre, B. and Penel, M. 1992. Diagnosis of mineral clogging hazards in subsurface drainage systems. In: *Proc. 5<sup>th</sup> Internat. Drainage Workshop*. W.F. Vlotman (ed.). Lahore, Pakistan, Vol. II, pp. 1.36-1.45.
- Luthin, J. 1978. *Drainage Engineering*. Robert E. Krieger Publishing Company, Huntington, NY, United States.
- Luthin, J.N. and Haig, A. 1972. Some factors affecting flow into drainpipes. *Hilgardia* **41**, **10**: 235-245.
- Madramootoo, C.A., Johnston, W.R. and Willardson, L.S. 1997. Management of agricultural drainage water quality. *FAO Water Report 13*, ICID/FAO, Rome.
- Martínez Beltrán, J. 1978. Drainage and Reclamation of Salt-affected Soils. *Publ. 24*, ILRI, Wageningen, The Netherlands.
- Martínez Beltrán, J. 1987. Drainage in Spanish land reclamation projects. In: Proc. Symp. 25<sup>th</sup> Internat. Course on Land Drainage. Twenty-Five Years of Drainage Experience. J. Vos (ed.). *Publ. 42*, ILRI, Wageningen, The Netherlands, pp. 180-194.
- Meijer, H.J. 1973. Enkele bepalingen van de factoren die gebruikt worden bij de kwaliteitseisen voor turfvezel voor drainage doeleinden [Some determinations of the factors which are used in conjunction with quality requirements for peat fibres which are applied for drainage purposes]. *Note 781*, ICW, Wageningen, The Netherlands.
- Meijer, H.J. and Knops, J.A.C. 1977. Veldonderzoek naar de bestendigheid van cocosvezels als afdek- en omhullingsmateriaal voor drainbuizen [Field survey into the persistency of coconut fibres as cover and wrapping material for drain pipes]. *Misc. Reprints 201*, ICW, Wageningen, The Netherlands.
- Merriam-Webster. 1993. *Collegiate Dictionary 10<sup>th</sup> ed.* Merriam-Webster Inc., Springfield, MA, United States.

- Metzger, J.F., Gallichand, J., Amer, M.H. and Bricieri-Colombi, J.S.A. 1992. Experiences with fabric envelope selection in a large subsurface drainage project in Egypt. In: *Proc. 5<sup>th</sup> Internat. Drainage Workshop*. W.F. Vlotman (ed.). Lahore, Pakistan, **Vol. III**, pp. 5.77-5.87.
- Mortensen, J.R. 1987. Comment made during discussion in sessions 1 and 4 in ILRI Symposium. In: *Proc. Symp. 25<sup>th</sup> Internat. Course on Land Drainage. Twenty-Five Years of Drainage Experience*. J. Vos (ed.). *Publ. 42*, ILRI, Wageningen, The Netherlands.
- Murillo, J.L. 1987. Land drainage in the Atlantic region of Costa Rica. In: *Proc. Symp. 25<sup>th</sup> Internat. Course on Land Drainage. Twenty-Five Years of Drainage Experience*. J. Vos (ed.). *Publ. 42*, ILRI, Wageningen, The Netherlands, pp. 286-290.
- Nieuwenhuis, G.J.A. and Wesseling, J. 1979. Effect of perforation and filter material on entrance resistance and effective diameter of plastic drain pipes. *Agric. Water Manage.* **2**: 1-9.
- NFU 51-161. 1990. *Drainage agricole. Produits d'enrobage: Essai en perméamètre* (Agricultural Drainage. Envelope Products: Permeameter Tests). AFNOR, Paris.
- NCRS. 1998. *Subsurface Drainage Standard and Specification 606*. U.S. Department of Agriculture, Natural Resource Conservation Service, Washington, DC.
- Ochs, W.J. and Bishay, G.B. 1992. Drainage guidelines. *Technical Paper 195*. World Bank, Washington, DC.
- Olbertz, M.H. and Press, H. 1965. Landwirtschaftlichen Wasserbau [Agricultural water management]. In: *Taschenbuch der Wasserwirtschaft. Wasser und Boden, 4<sup>th</sup> ed.*. H. Press (ed.). Hamburg, Germany, pp. 447-555.
- Oosterbaan, R.J. 1998. *Personal communication*. Staff member of ILRI, Wageningen, The Netherlands.
- Peschl, I.A.S.Z. 1969. *Gewelfvorming in bunkers* [The Development of Stable Arches in Bunkers]. Ph.D. Thesis. Technical University, Eindhoven, The Netherlands.
- Pillsbury, A.F. 1967. Observations on tile drainage performance. *Proc. ASCE* **93**, **IR3**: 233-241.
- prEN 13 562. 1999. *Geotextiles and Geotextile-related Products - Determination of Penetration Resistance by Water (Hydrostatic Head Test)*. CEN, Brussels.
- prEN 30 318. 1998. *Geotextiles and Geotextile-related Products - Terminology (draft)*. CEN, Brussels.
- Qureshi, S., Kogler, R.M. and Bhatia, S.K. 1990. Long term filtration behaviour of nonwoven geotextiles. In: *Proc. 4<sup>th</sup> Internat. Conf. on Geotextiles, Geomembranes and Related Products*. G. den Hoedt (ed.). A.A. Balkema, Rotterdam, The Netherlands. **Vol. 1**, pp. 279-283.
- Rajad Project Staff. 1995. *Analysis of Subsurface Drainage Design Criteria*. Rajasthan Agricultural Drainage Research Project (Rajad). Chambal Command Area Development, Rajasthan, India.
- Rankilor, P.R. 1992. *UTF Geosynthetics Manual - a Technical Manual for the Design of UTF Geosynthetics into Civil and Marine Engineering Projects*. UCO Technical Fabrics NV, Lokeren, Belgium.
- Richards, L.A. 1954. Diagnosis and improvement of saline and alkaline soils. *USDA Handbook 60*, Washington DC.
- Ritzema, H.P. 1997. Report on the drainage research course; Indo-Dutch network programme for operational research on the control of waterlogging and salinization in irrigated agricultural lands. *Unpubl. working paper*, ILRI, Wageningen, The Netherlands.
- Rollin, A.L., Broughton, R.S. and Bolduc, G.F. 1987. Thin synthetic envelope materials for subsurface drainage tubes. *Geotextiles and Geomembranes* **5**, **2**: 99-122.
- Rozendaal, H. and Scholten, J. 1980. Risico's voor drainage met turf/molmafdekking bij infiltratie in lichte gronden [The risk of wrapping drains with peat litter envelope material in case of subirrigation in sandy soils]. *Cult. Techn. Tijdschr.* **19**, **6**: 327-334.

- Salem, H.A. and Willardson, L.S. 1992. Evaluation of Non-Standard Synthetic Envelope Materials. In: *Proc. 5<sup>th</sup> Internat. Drainage Workshop*. W.F. Vlotman (ed.). Lahore, Pakistan, **Vol. I**, 219-227.
- Samani, Z.A. and Willardson, L.S. 1981. Soil Hydraulic Stability in a Subsurface Drainage System. *Trans. ASAE* **24**, **3**: 666-669.
- Saulmon, R.W. 1971. Need for envelope material above draitile. *J. Irr. and Drain. Div., Proc. ASCE* **95**, **IR1**: 199-209.
- Scholten, J. and Ven, G.A. 1987. Het schatten van het risico van ijzerafzetting in drains volgens de methode Ford [Assessment of the risk of iron ochre clogging of drains following the Ford method]. *Werkdocument 15 cbw*. Government Service for the IJssellake Polders, Lelystad, The Netherlands.
- Scholten, J. 1988. Vijftientig jaar drainagematerialenonderzoek bij de Rijksdienst voor de IJsselmeerpolders [Twenty-five years of drain envelope research by the Dutch Polder Development Authority]. *Flevobericht 291*, Ministerie van Verkeer en Waterstaat. The Netherlands.
- Schultz, B. (ed.). 1990. *Guidelines on the Construction of Horizontal Subsurface Drainage Systems*. Working Group on Drainage Construction, ICID, New Delhi.
- Schwab, G.O. and Fouss, J.L. 1999. Drainage materials. In: *Agricultural Drainage*. R.W. Skaggs and J. Van Schilfgaarde (eds.). *Agron. Monogr.* 38. ASA, CSSA, and SSSA, Madison, WI, United States, pp. 911-926.
- Segeren, W.A. and Zuidema, F. 1969. Ontwikkelingen in de drainagetechniek [Developments in land drainage techniques]. In: *Cultuurtechnische verhandelingen*. Ministerie van Landbouw en Visserij, The Hague, pp. 325-357.
- Sherard, J.L., Dunnigan, L.P. and Talbot, J.R. 1984a. Basic Properties of Sand and Gravel Filters. *Journ. Geotech. Engr. Amer. Soc. Civil Eng.* **110**, **6**: 684-700.
- Sherard, J.L., Dunnigan, L.P. and Talbot, J.R. 1984b. Filters for Silts and Clays. *Journ. Geotech. Engr. Amer. Soc. Civil Engr.* **110**, **6**: 701-718.
- Shi, Y.C., Fannin, R.J. and Vaid, Y.P. 1994. Interpretation of gradient ratio test results. In: *Proc. 5<sup>th</sup> Internat. Conf. on Geotextiles, Geomembranes and Related Products*. G.P. Karunaratne, S.H. Chew and K.S. Wong (eds.). Singapore, **Vol 2**, pp. 673-676.
- Singh, P.K. 1987. Drainage problems in India. In: *Proc. Symp. 25<sup>th</sup> Internat. Course on Land Drainage. Twenty-Five Years of Drainage Experience*. J. Vos (ed.). *Publ.* 42, ILRI, Wageningen, The Netherlands, pp.278-285.
- Smedema, L.K. and Rycroft, D.W. 1983. *Land Drainage: Planning and Design of Agricultural Drainage Systems*. Batsford, London.
- SCS. 1971. Drainage of agricultural land. *USDA National Engineering Handbook, Section 16*. USDA Soil Conservation Service, Washington, DC.
- SCS. 1973. *Drainage of Agricultural Lands*. A practical handbook for the planning, design, construction and maintenance of agricultural drainage systems. USDA Soil Conservation Service. Water Information Center Inc., Port Washington, NY, United States.
- SCS. 1988. *Standards and Specifications for Conservation Practices. Standard on Subsurface Drains 606*. USDA Soil Conservation Service, Washington, DC.
- SCS 606. 1980. Engineering practice for subsurface drains. Specifications for corrugated polyvinyl chloride drainage tubing. *Code 606*. USDA-SCS, Washington, DC.
- Stuyt, L.C.P.M. 1982. Drainage envelope research in The Netherlands. In: *Proc. 2<sup>nd</sup> Internat. Drainage Workshop*. Washington, DC, pp. 106-123.
- Stuyt, L.C.P.M. 1992a. *The Water Acceptance of Wrapped Subsurface Drains*. Ph.D. Thesis, Agric. Univ.

- Wageningen/DLO-Winand Staring Centre (SC-DLO), Wageningen, The Netherlands.
- Stuyt, L.C.P.M. 1992b. Mineral clogging of wrapped subsurface drains, installed in unstable soils: a field survey. In: *Proc. 5<sup>th</sup> Internat. Drainage Workshop*. W.F. Vlotman (ed.). Lahore, Pakistan, **Vol. III**, pp. 5.50-5.64.
- Stuyt, L.C.P.M. 1992c. Effect of drain envelopes on the water acceptance of wrapped subsurface drains. In: *Proc. 6<sup>th</sup> Internat. Drainage Workshop*. ASAE, St Joseph, MI, United States, pp. 257-263.
- Stuyt, L.C.P.M. and Oosten, A.J. 1986. A non-destructive morphological study of mineral clogging of drains. In: *Proc. of Internat. Seminar on Land Drainage*. J. Saavalainen and P. Vakkilainen (eds.). Helsinki University of Technology, Finland, pp. 90-111.
- Stuyt, L.C.P.M. and Willardson, L.S. 1999. Drain Envelopes. In: *Agricultural Drainage*. R.W. Skaggs and J. Van Schilfgaarde (eds.). *Agron. Monogr. 38*. ASA, CSSA, and SSSA, Madison, WI, United States, pp. 927-962.
- Terzaghi, K. and Peck, R.B. 1961. *Die Bodenmechanik in der Baupraxis* [Soil Mechanics in Building Construction]. Springer, Berlin.
- Terzaghi, K. and Peck, R.B. 1965. *Mécanique des sols appliquée aux travaux publics et au bâtiment* [Soil Mechanics in Public Works and in Buildings]. Dunod, Paris.
- U.S. Army Corps of Engineers. 1941. Investigation of filter requirements for underdrains. *Eng. Waterways Exp. Sta., Tech. Memo. 183-1*.
- U.S. Army Corps of Engineers. 1977. Civil Works Construction Guide. Specification for Plastic Filter Fabrics. *Specification N° CW-02215*. Office, Chief of Engineers. Washington, DC.
- USBR. 1974. *Standard Specifications for Polyethylene Plastic Corrugated Drainage Tubing*. United States Department of the Interior, Bureau of Reclamation, Engineering and Research Center, Denver, CO, United States.
- USBR. 1976. *Tentative Standard Specifications for Polyvinyl-chloride Corrugated Drainage Tubing*. United States Department of the Interior, Bureau of Reclamation, Engineering and Research Center, Denver, CO, United States.
- USBR. 1978. *Drainage Manual*. United States Department of Interior, Bureau of Reclamation, Denver, CO, United States.
- USBR. 1981. *Tentative Standard Specifications for Large-diameter Polyethylene and Polyvinyl-chloride Corrugated Drainage Tubing and Foamed Smooth Wall ABS Drain Pipe*. United States Department of the Interior, Water and Power Resources Service, Engineering and Research Center, Denver, CO, United States.
- USBR. 1993. *Drainage Manual, 2<sup>nd</sup> ed.* United States Department of the Interior, Bureau of Reclamation, Denver Federal Center, Denver, CO, United States.
- Van der Louw, C. 1986. Drainoscopie, een optische inspectiemethode voor drainagesystemen [Drainoscopy, an optical inspection method for subsurface drains] *Cultuurtechnisch Tijdschrift* **25, 5**: 357-367.
- Van der Meer, K. and Willet, J.R. 1964. The pedomorphological aspect of mechanical soil improvement. 8th Int. Congr. Soil Sci. *Summary in Tijdschrift Koninklijke Nederlandse Heidemaatschappij* **75, 12**: 628-634.
- Van der Molen, W.H. 1972. *Waterbeheersing* [Water Management]. Revised ed. Lecture notes, Agricultural University Wageningen, The Netherlands.
- Van der Molen, W.H. and Van Someren, C.L. 1987. Comment made during discussion in session 1 in ILRI Symposium. In: *Proc. Symp. 25<sup>th</sup> Internat. Course on Land Drainage. Twenty-Five Years of Drainage Experience*. J. Vos (ed.). *Publ. 42*, ILRI, Wageningen, The Netherlands.



- Van Hoorn, J.W. and Bouma, J. 1981. Het functioneren van buisdrainage op komgrond [Performance of pipe drainage in backland]. *Cultuurtechnisch Tijdschrift* **20**: 325-334.
- Van Schilfgaarde, J. 1971. Drainage yesterday, today, and tomorrow. *Proc. ASAE Nat. Drain. Symp.* St. Joseph, MI, United States.
- Van Someren, C. L. 1972. Drainage materials. Synthesis. In: *FAO Irrigation and Drainage Paper 9*, Rome, pp. 1-30.
- Van Zeijts, T.E.J. 1987. Quality control of subsurface drainage works in the Netherlands. *Proc. 3<sup>rd</sup> Intern. Workshop on Land Drainage*. Ohio State University, Columbus, OH, United States, pp.117-124.
- Van Zeijts, T.E.J. 1992. Recommendations of the use of envelopes, based on experience in The Netherlands. In: *Proc. 5<sup>th</sup> Internat. Drainage Workshop*. W.F. Vlotman (ed.). Lahore, Pakistan, **Vol. III**, pp. 5.88-5.96.
- Van Zeijts, T.E.J. and Bons, A. 1993. Effects of jet flushing on drain performance and sustainability. *Trans. 15<sup>th</sup> International Congress on Irrigation and Drainage, The Hague*. ICID, New Delhi. pp. 437-450.
- Van Zeijts, T.E.J. and Naarding, W.H. 1990. Possibilities and limitations of trenchless pipe drain installation in irrigated areas. In: *Installation of pipe drains. Current Papers on Machinery and Quality Control. Information Paper 21*, Govt. Service for Land and Water Use, Utrecht, The Netherlands.
- Van Zeijts, T.E.J. and Zijlstra, L. 1990. Rodding, a simple method for checking mistakes in drain installation. In: *Symposium on Land Drainage for Salinity Control in Arid and Semi-Arid Regions*. Drainage Research Institute, Cairo, **Vol III**, pp. 84-93.
- Veldhuijzen van Zanten, R. 1986. *Geotextiles and Geomembranes in Civil Engineering*. A.A. Balkema, Rotterdam, The Netherlands.
- Ven, G.A. 1986. The effect of maintenance of tube drains. In: *Agricultural Water Management. Proc. Symp. on Agric. Water Management*. A.L.M. Van Wijk and J. Wesseling (eds.). A.A. Balkema, Rotterdam, The Netherlands, pp 203-211.
- Vlotman, W.F. (ed.). 1990. *Proceedings Workshop on Drain Envelope Testing, Design and Research. IWASRI Publ. 49*, IWASRI/NRAP, Lahore, Pakistan.
- Vlotman, W.F., Shafiq-ur-Rehman and Bhutta, N.M. 1992a. Drain Envelope Design under Review. *ASAE Paper No. 922649*. ASAE. St. Joseph, MI, United States.
- Vlotman, W.F., Shafiq-ur-Rehman and Haider, I. 1992b. Granular envelope research in Pakistan. In: *Proc. 5<sup>th</sup> Internat. Drainage Workshop*. W.F. Vlotman (ed.). Lahore, Pakistan, **Vol. III**, pp. 5.38-5.49.
- Vlotman, W.F., Willardson, L.S. and Dierickx, W. 1997. Drain envelope need, selection, design, construction and maintenance. In: *Proc. 7<sup>th</sup> ICID Int. Drain. Workshop*. Penang, Malaysia, **Vol. 2**, pp. 22.1- 22.16.
- Vlotman, W.F., Willardson, L.S. and Dierickx, W. 2000. Envelope design for subsurface drains. *Publ. 57*, ILRI, Wageningen, The Netherlands.
- Vlotman, W.F., Zuberi, F.A., and Khan, M.A. 1990. Gravel Envelope Selection, Design and Installation. In: *Proc. Workshop on Drain Envelope Testing, Design and Research*. W.F. Vlotman (ed.). IWASRI, Lahore, Pakistan, pp. 3-31.
- Von Scheffer, B. 1982. Spülung von Dränen des Dränversuchsfelder Bokern [Drain jetting in pilot area Bokern]. *Zeitschr. für Kulturtechnik und Flurbereinigung* **23**: 110-114.
- Vos, J. (ed.). 1987. *Proc. Symp. 25<sup>th</sup> Internat. Course on Land Drainage. Twenty-Five Years of Drainage Experience. Publ. 42*, ILRI, Wageningen, The Netherlands.
- Watts, D.G. and Luthin, J.N. 1963. Tests of thick fiberglass filters for subsurface drains. *Hilgardia* **35**, **3**: 35-46.

- Weaver, M. M. 1964. *History of Tile Drainage*. Private publication, Waterloo, NY, United States.
- Wesseling, J. 1967. Drainage experiments. *Lecture Notes 6<sup>th</sup> Internat. Course on Land Drainage*, ILRI, Wageningen, The Netherlands.
- Wesseling, J. 1987. The development of drainage in humid temperate regions. In: Proc. Symp. 25<sup>th</sup> Internat. Course on Land Drainage. Twenty-Five Years of Drainage Experience. J. Vos (ed.). *Publ. 42*, ILRI, Wageningen, The Netherlands, pp. 14-21.
- Wesseling, J. and Homma, F. 1967. Entrance resistance of plastic drain tubes. *Neth. J. Agric. Sci.* **15**: 170-182.
- Wesseling, J. and Van Someren, C.L. 1972. Provisional report of the experience gained in the Netherlands. In: Drainage materials. *FAO Irrigation and Drainage Paper 9*. Rome, pp. 55-84.
- Widmoser, P. 1968. Der Einfluss von Zonen geänderter Durchlässigkeit im Bereich von Drän- und Brunnenfilterrohren. [The effect of zones with modified permeability in the vicinity of drain and well pipes]. *Schweizerische Bauzeitung* **86, 9**: 135-144.
- Willardson, L.S. 1974. Envelope materials. In: Drainage for Agriculture. J. Van Schilfgaard (ed.). *Agronomy 17*. Am. Soc. of Agronomy, Madison, WI, United States, pp. 179-202.
- Willardson, L.S. 1979. Hydraulic gradients in envelope materials. Factors influencing water and particle movement into drains. *USDA-SEA. ARR-W-8*, pp. 65-70.
- Willardson, L.S. and Walker, R.E. 1979. Synthetic drain envelope-soil interactions. *Proc. Irrig. and Drain. Div. ASCE* **105, IR4**: 367-373.
- Willardson, L.S., Aquirre, X. and Watkins, R.K. 1980. Plastic drain response in soft envelope material. *Trans. ASAE*, **23**: 1402-1408.
- Willet, J.R. 1962. 'Ongerijpte' zandgronden en hun ontwatering [Drainage of 'unripened' sandy soils]. *Tijdschrift Koninklijke Nederlandse Heidemaatschappij* **73, 12**: 403-408.
- Winger, R.J. 1973. *Operation and Maintenance Standards for Irrigation Project Drainage Systems*. Irrigation Operator's Workshop, USBR, Eng. and Res. Center, Denver, CO, United States.
- Woudeneh, T. 1987. The Melka Sadi Pilot Drainage Scheme. In: Proc. Symp. 25<sup>th</sup> Internat. Course on Land Drainage. Twenty-Five Years of Drainage Experience. J. Vos (ed.). *Publ. 42*, ILRI, Wageningen, The Netherlands, pp. 261-267.
- Ziems, J. 1969. *Beitrag zur Kontakterosion nichtbindiger Erdstoffe* [Contribution to contact erosion of cohesionless mineral materials]. Ph.D.-Thesis, Techn. Univ. Dresden, Germany.
- Zijlstra, G. 1987. Drainage machines. In: Proc. Symp. 25<sup>th</sup> Internat. Course on Land Drainage. Twenty-Five Years of Drainage Experience. J. Vos (ed.). *Publ. 42*, ILRI, Wageningen, The Netherlands, pp. 74-81.

# Annex

## Draft European standard on corrugated polyvinyl chloride drainpipes

### INTRODUCTION

This Annex contains the draft European standard on corrugated polyvinyl chloride drainpipes as it was at the moment that its standardization work came to a standstill. Consequently, this document exhibits some shortcomings and imperfections.

As can be seen from the 'Foreword' of the draft standard, it should consist of seven parts. The current version of this Annex has only 6 parts. Part 7 on 'Evaluation of Conformity' was and is not yet available because the Commission of the European Union has to impose the kind of evaluation of conformity that applies to 'Plastics Piping Systems for Agricultural Land Drainage (PVC-U)'.

The main drawback of the existing document concerns references. Frequently references to which is referred, are not included in the normative references, or they contain references which do not apply. References of draft documents or standards are not updated since the standstill and may not be useful anymore. Sometimes references in the various parts of the draft standard do not match.

Symbols are not always defined and lack units, while other symbols are defined but not used. Moreover the used symbols were not always straightforward. Furthermore other discrepancies were found throughout the document.

These shortcomings do not question the value and the importance of the present draft standard, but they may disturb those who consider the standard more closely. Some obvious discrepancies and inconsistencies have been amended, yet with the risk to introduce additional errors. Other ambiguities are maintained because correct information on what would be most likely to be correct could not be obtained.

The draft EN-standard on corrugated polyvinyl chloride drainpipes is a useful document, in spite of the above-mentioned drawbacks, which would certainly disappear if the standardization work could be finalized. The draft standard gives information on requirements for drainpipes, fittings, envelope materials and on installation practice, and can be useful for countries with little or no experience with current drainage materials. Therefore it was decided to include the draft standard in this FAO Irrigation and Drainage Paper.

**CORRUGATED PLASTIC PIPING SYSTEMS  
FOR LAND DRAINAGE  
UNPLASTICIZED POLYVINYL CHLORIDE (PVC-U)**

**FOREWORD**

This draft European standard has been prepared under a mandate given to CEN by the European Commission and the European Free Trade Association, and supports essential requirements of EU Directives.

It was prepared by CEN/TC 155 “Plastics piping and ducting systems”/WG 18 “Subsoil drainage piping systems”. It did not yet receive approval and is therefore not yet mandatory for the CEN members.

This standard for corrugated plastic piping systems made of unplasticized polyvinyl chloride for agricultural, horticultural and sportsfield drainage is part of a system standard for plastic piping systems.

System standards are based on the results of the work being undertaken in ISO/TC 138 “Plastics pipes, fittings and valves for the transport of fluids”, which is a Technical Committee of the International Standardisation Organisation (ISO).

They are supported by separate standards on test methods to which references are made throughout the system standard.

The system standard relates to standards on general functional requirements and recommendations for installation.

This standard consists of the following Parts, under the general title “Corrugated plastic piping systems for land drainage, unplasticized polyvinyl chloride (PVC-U)”:

- Part 1: General,
- Part 2: Pipes without envelope,
- Part 3: Fittings,
- Part 4: Envelopes,
- Part 5: Fitness for purpose of the system,
- Part 6: Recommended practice for installation,
- Part 7: Evaluation of conformity.

This European standard specifies the required properties for the piping system made from unplasticized polyvinyl chloride and its components, when intended to be used for land drainage. It includes recommended practice for installation and the required level of certification.

This standard is intended to be used by authorities, design engineers, testing and certification institutes, manufacturers and users.

This standard is applicable to unplasticized polyvinyl chloride (PVC-U) piping systems to gather and convey excess water by gravity. Agriculture, horticulture and sportfields constitute the fields for these systems.

Pipes for these systems cover a nominal diameter range from *DN 50* to *DN 1000*. Above *DN 630*, pipe are not presently manufactured.

European standards incorporate by reference provisions from specific editions of certain other publications. These normative references are cited at the appropriate points in the text and the publications are listed in the standard. Subsequent amendments to, or revisions of, any of these publications apply to this European Standard only when incorporated in it by amendment or revision.

## PART 1: GENERAL

### 1 SCOPE

Part 1 specifies the general aspects, the material requirements and the test parameters for test methods referred to in the system standard.

### 2 NORMATIVE REFERENCES

- ISO 2507. Thermoplastic pipes and fittings - Vicat softening temperature - Test method and basic specification.
- ISO 1183. PVC-U pipes and fittings - Determination and specification of density.
- CEN/TC 155 N 708 Rev. Proposal for text regarding material including reprocessible and recyclable materials for individual systems standards. 1992.07.01. 18 pp.
- CEN/TC 155 WI 137. Determination of PVC content.
- CEN/TC 155 WI 043. Determination of Vicat softening temperature.

### 3 DEFINITIONS

For the purposes of this Part the following definitions and abbreviations apply :

**3.1 Land drainage:** Removal of surface or subsurface water from land.

**3.2 Virgin material:** Material in a form such as granules or powder that have not been subjected to use or processing other than that required for its manufacture and to which no reprocessible or recyclable materials have been added.

**3.3 Own reprocessible material:** Material prepared from rejected PVC-U unused pipes and fittings, including trimmings from that production of pipes and fittings, that will be reprocessed in a manufacturer's plant after having been previously processed by the same manufacturer by a process such as moulding or extrusion, provided the complete formulation is known.

**3.4 External reprocessible material:** Material comprising either one of the following forms :

- a) Material from rejected unused PVC-U pipes or fittings or trimmings, that will be reprocessed and that were originally processed by another manufacturer.
- b) Material from the production of unused PVC-U products other than pipes and fittings, regardless of where they are manufactured, that will be reprocessed into pipes and/or fittings.

**3.5 Recyclable material:** Material comprising either one of the following forms :

- a) Material from used PVC-U pipes or fittings which have been cleaned and crushed or ground.
- b) Material from used PVC-U products other than pipes or fittings which have been cleaned and crushed or ground.

**3.6 Nominal diameter (DN):** A numerical designation of diameter which is common to all components in a piping system. It is a convenient round number for reference purposes approximate to the manufacturing diameter, expressed in mm. For this system standard, it is based on the outside diameter of the corrugated pipes. For Scandinavia, nominal diameters are based on inside diameter.

## **4 MATERIALS**

### **4.1 General**

The material of the pipes and fittings shall consist substantially of PVC-U material to which may be added only those additives that are needed to facilitate the manufacture of good surface finish and mechanical strength pipe, conforming to this standard.

### **4.2 Minimum PVC content**

When tested in accordance with CEN/TC 155 WI 137, the content of PVC shall be at least 80 percent by mass for pipes and 88 percent by mass for fittings. In case of use of virgin and own reprocessable material, the minimum PVC content can be calculated.

*NOTE: The minimum PVC content of fittings fabricated from pipe shall conform to the content required for the pipe.*

### **4.3 Virgin material**

The use of virgin material is permissible without limitation.

### **4.4 Reprocessable and recyclable materials**

#### **4.4.1 Own reprocessable materials**

The use of own reprocessable material for production of pipes and fittings is permitted without limitation. If fitting material is used for pipes, it shall be considered as recyclable material.

#### **4.4.2 External reprocessable and recyclable materials with agreed specifications**

External reprocessable and recyclable materials from pipes and fittings of PVC-U that are available in relevant quantities and frequencies may be added to virgin or own reprocessable material or a mixture of those two materials for production of pipes and shall be added only under the following conditions.

- a) A specification of the material shall be agreed between the supplier of reprocessable or recyclable material, the pipe manufacturer and the certification body. It shall at least cover the characteristics given in Table 1. When determined in accordance with the methods given in Table 1 the actual values for these characteristics shall conform to the agreed values within the deviations permitted in Table 1. The quality system of the supplier of reprocessable or recyclable material shall be certified to ISO EN 9002.
- b) Each delivery shall include a certificate showing conformity to the agreed specification.
- c) The maximum quantity of reprocessable and recyclable material that is to be added to the virgin material is specified by the pipe manufacturer.
- d) The quantity of reprocessable and recyclable material that is actually added to the virgin material in each production series shall be recorded by the pipe manufacturer.
- e) The PVC content of the end product shall meet the requirements specified in 4.2.

**TABLE 1**  
**Specification of characteristics to be covered by the agreement and maximum allowable tolerances for these items**

Characteristic	Unit	Test method	Maximum permitted deviations
PVC content <sup>*)</sup>	% by mass	WI 137	± 4 % absolute
K value <sup>*)</sup>		WI 083	± 3 units
Density <sup>*)</sup>	kg/m <sup>3</sup>	ISO 1183	± 20
Vicat softening temperature <sup>*)</sup>	°C	prEN 727	± 2 units
Particle size <sup>1)</sup>	Requirements shall be agreed and stated in the specification.		
Type of stabilizer <sup>1)*)</sup>	Requirements shall be agreed and stated in the specification.		
Impurities <sup>1)</sup>	Based on the source of material and the recycling process a relevant test method and requirements shall be agreed and stated in the specification. Both the test method and the requirements shall be published.		
1) The relevant requirements depend on the recycling process and on the end product.			
*)If the source of the material is pipes and fittings produced with a national or European quality mark, those material characteristics specified in that relevant standard, in such a way that one or more of the requirements to characteristics marked with "*" are satisfied, do not have to be tested.			

f) Type testing of the end product shall be carried out for the maximum specified amount and for each type of reprocessable or recyclable material with agreed specification.

#### **4.4.3 External reprocessable and recyclable material not covered by an agreed specification**

PVC-U pipes and fittings shall not contain this type of material.

#### **5 REFERENCE CONDITIONS FOR TESTING**

The mechanical and physical properties specified in all Parts of this standard shall, unless otherwise specified, be determined at  $23 \pm 2^\circ\text{C}$ .



## PART 2: PIPES WITHOUT ENVELOPE

### 1 SCOPE

Part 2 specifies the required properties for PVC-U pipes.

### 2 NORMATIVE REFERENCES

- prEN 496. 1991. Plastic piping systems - Plastic pipes and fittings - Measurements of dimensions and visual inspection of surfaces.
- EN 1411. Plastic piping and ducting systems - Thermoplastics pipes - Determination of the resistance to external blows by the staircase method.
- CEN/TC 155 WI 124. Extensibility.
- CEN/TC 155 WI 125. Brittle fracture test.
- ISO 3. Normal numbers, normal numbers series.
- ISO 2507. Thermoplastic pipes and fittings - Vicat softening temperature - Test method and basic specification.  
ISO 2507-1. Vicat softening temperature Part 1: General method.  
ISO 2507-2. Vicat softening temperature Part 2: Special conditions for PVC-U, PVC-C and PVC-HI pipes.
- ISO 3126. Out-of-roundness.
- ISO 9967. Thermoplastic pipes - Determination of creep ratio.
- ISO 9969. Thermoplastic pipes - Determination of ring stiffness - Constant speed method.

### 3 DEFINITIONS

For the purposes of this part, the definitions, and abbreviations given in Part 1 apply together with the following.

**3.1 Nominal diameter ( $DN$ ):** Numerical designation of the outside diameter ( $D_o$ ) of the pipe declared by the manufacturer. For Scandinavia, nominal diameter is based on internal diameter ( $D_i$ ) as stated in Table 3.

**3.2 Mean outside diameter:** The measured length of the outer circumference of the pipe, divided by  $\pi$  ( $= 3.142$ ) and rounded to the next higher 0.1 mm.

**3.3 Total length:** The distance between two planes normal to the pipe axis and passing through the extreme end points of the pipes measured along the axis of the pipe.

**3.4 Nominal length:** Numerical designation of a pipe length declared by the manufacturer which is equal to the pipe's total length in metres stated as a whole number.

**3.5 Ring stiffness:** The value of initial resistance to radial deflection under external load obtained by testing in accordance with ISO 9969.

**3.6 Creep ratio:** A physical characteristic of the pipe obtained by testing in accordance with ISO 9967. It is a measure of the long-term resistance to radial deflection under external load.

### 4 PIPE MATERIAL

The material from which the pipes are made shall conform to the requirements given in Part 1.

**TABLE 1**  
**Pipe material characteristic**

Characteristic	Unit	Requirement	Test parameter	Test method
Vicat	°C	minimum 77	1 mm penetration 50 ± 1 N	TC 155 WI 043 (ISO 2507)

## 5 GENERAL REQUIREMENTS

### 5.1 Appearance

When viewed without magnification the internal and external surfaces of pipes shall be clean and free from scoring and other surface defects. The surface shall not be tacky. The ends of the pipe shall be square to the axis of the pipe and cut cleanly.

*NOTE: The pipe may be of any colour.*

### 5.2 Nominal length and coil size

Unless otherwise specified, pipes longer than 20 m up to  $DN$  200 shall be delivered in coils and pipes greater than  $DN$  200 shall be delivered in straight lengths.

Unless otherwise specified, coiled pipes longer than 20 m shall be supplied in lengths of any multiple of 5 m. In order to fit continuous laying machines, the internal and outside diameters of a coil of pipe shall be agreed between the interested parties, provided that the functional requirements of this standard are conformed to.

Straight lengths longer than 3 m shall be supplied in lengths of any multiple of 1 m.

### 5.3 Total length

The total length of the pipe shall not be less than the nominal length declared by the manufacturer.

## 6 GEOMETRICAL CHARACTERISTICS

### 6.1 Diameter

*NOTE: The general approach is for the values of the outside diameters to be the reference for designation by nominal size. Manufacturers whose nominal diameters are based on  $D_i$  shall comply with the corresponding outside diameter as declared by the manufacturer for the referring standard.*

This part does not include requirements for wall thickness for pipes, and it is not intended to include such requirements at a later date. This is to allow the maximum possible freedom in the choice of design.

Method of measurement shall comply with the method given in prEN 496.

#### 6.1.1 Nominal diameter

The nominal diameter shall be chosen from those given in Table 2.

**TABLE 2**  
Nominal Diameters  $DN/D_o$  (based on  $D_o$ )

50	60	65	80	100	125	160	200 <sup>1</sup>
250	280	(296)	315	355	(375)	400	450
(470)	(475)	500	560	(580)	630 <sup>2</sup>		

<sup>1</sup> For any new production of  $DN$  above 200, the Renard series R20 dimensions in the table shall be chosen as specified in ISO 3 (the non-R20 dimensions in Table 2 shown in brackets are not preferred).  
<sup>2</sup> Above  $DN$  630, pipes are not presently manufactured.  $DN$  710, 800, 900, 1 000 are the preferred dimensions for this upper range of nominal diameters.

Diameter sizes based on internal diameter are given in Table 3.

**TABLE 3**  
Diameter sizes based on  $D_i$

Mean inside diameter $D_i$ (mm)	Permitted deviations (mm)	Corresponding outside diameter $D_o$ (mm)
50	-0 +2	58
65	-0 +2	75
80	-0 +3	92
113	-0 +3	127
145	-0 +5	160
180	-0 +5	200

Inclusion of these diameters shall be reconsidered at the first revision of this system standard.

### 6.1.2 Minimum inside diameters

When measured to an accuracy of 0.1 mm or 0.05 % whichever is the greater value, the average of the measured mean inside diameters shall not be less than the minimum  $D_i$  given in Table 4 for the relevant nominal diameter,  $DN$ . An internal micrometer or a plug gauge with an accuracy of 0.1 mm shall be used for the measurement of the inside diameter up to 180 mm. Above  $D_i$  180 mm, any suitable measurement device may be used.

**TABLE 4**  
Minimum inside diameters (based on  $D_o$ )

$DN/D_o$	$D_i$ min mm	$DN/D_o$	$D_i$ min mm
50	43	315	280
60	52	355	315
65	57	375	315
80	70	400	355
100	90	450	400
125	113	470	417
160	143	475	400
200	180	500	450
250	224	560	500
280	250	580	500
296	250	630	530

### 6.1.3 Tolerances on mean outside diameter

The mean outside diameter of a pipe shall not deviate from the nominal diameter by more than the permissible deviations given in Table 5 when measured in accordance with prEN 496.

**TABLE 5**  
Specified pipe mean outside diameters and tolerances

Nominal diameter $DN/D_o$	Permissible deviation from mean outside diameters	
	+ mm	- mm
$\geq 50$ and $\leq 100$	1.0	1.5
$\geq 125$ and $\leq 200$	1.5	1.5
$\geq 250$ and $\leq 400$	1.5	2.0
$\geq 450$ and $\leq 630$	1.5	4.0

## 6.2 Out-of-roundness

### 6.2.1 Requirement

When measured in accordance with 6.2.3 using test pieces conforming to 6.2.2, the out-of-roundness  $O$ , shall be less than the applicable value given in Table 6 equivalent to 10 percent of  $DN$ , where (in accordance with ISO 3126)  $O$ , in mm, is given by the following equation:

$$O = D_{o \max} - D_{o \min}$$

where :  $D_{o \max}$  is the maximum outside diameter, in mm;  
 $D_{o \min}$  is the minimum outside diameter, in mm.

**TABLE 6**  
Specification of the out-of-roundness

$DN/D_o$	$O$ (mm)	$DN/D_o$	$O$ (mm)
50	5.0	315	31.5
60	6.0	355	35.5
65	6.5	375	37.5
80	8.0	400	40.0
100	10.0	450	45.0
125	12.5	470	47.0
160	16.0	475	47.5
200	20.0	500	50.0
250	25.0	560	56.0
280	28.0	580	58.0
296	30.0	630	63.0

### 6.2.2 Length of test pieces

The length  $L$ , in metres, of the test pieces shall be as follows :

$$L = 0.2 \pm 5 \% \text{ for pipes with } DN \leq 200;$$

$$L = 0.4 \pm 5 \% \text{ for pipes with } DN > 200.$$

### 6.2.3 Test method

On each test piece, mark four generating lines with an angle of approximately  $45^\circ$  between them and in a plane square to the pipe axis.

Using a slide calliper conforming to prEN 496, measure the four corresponding diameters and record the four individual measurements. Calculate the difference between the highest value and the lowest value and relate the difference to the nominal value as specified in 6.2.1.

## 6.3 Perforations

### 6.3.1 General

Perforations to admit water shall be in the form of slots and made in the valleys of the corrugations. Inspection to verify conformity shall be made on a  $1 \pm 0.01$  m length of pipe taken at random.

### 6.3.2 Distribution of perforations

Perforations shall be arranged in any pattern which provides an even distribution around the whole of the circumference in not less than four rows, with at least two perforations per 100 mm of each single row.

### 6.3.3 Perforation width

#### 6.3.3.1 Nominal perforation width

The chosen and declared nominal perforation width shall be between 1.0 mm and 2.3 mm by increment of 0.1 mm.

#### 6.3.3.2 Tolerances

The average perforation width shall not deviate more than 0.2 mm from the declared nominal perforation width.

No single perforation shall exceed the nominal perforation width by more than + 0.4 mm.

### 6.3.4 Perforation area

The total area  $A$  (see 6.3.5.4) of effective perforations per metre of pipe shall not be less than  $1200 \text{ mm}^2$ .

### 6.3.5 Test method

#### 6.3.5.1 Sampling

On a piece of pipe  $1 \pm 0.01$  m long, determine the number of rows of perforations  $n$ , for each row, without taking into account the quality of the perforations, count the number of perforations,  $a_1, a_2, \dots, a_n$ . Add up  $N = a_1 + a_2 + \dots + a_n$ . Without taking into account the quality of the perforations, using a table of random numbers, mark  $P$  perforations in each row in accordance with Table 7.

**TABLE 7**  
**Number of perforations  $P$  for control of perforations**

Number of perforation rows ( $n$ )	4	5	6	7	8	9	10	11	12
Number of perforations to be marked on each row ( $P$ )	10	8	7	6	5	5	4	4	4

### 6.3.5.2 Measurement

The measurement of the perforation dimensions (width and length) shall be carried using a calliper rule or an episcope.

In case of an imperfect perforation (see 6.3.5.3), the area of the perforation shall be taken as equal to zero.

### 6.3.5.3 Criteria for imperfect perforations

A perforation shall be considered as imperfect in any of the following cases :

- a) the perforation does not conform to 6.3.3.2 for its width;
- b) perforation is not made;
- c) a piece of material is still attached to the pipe on the perforation circumference.

### 6.3.5.4 Calculations

Add the surface areas of the  $n P$  perforations. Let this be  $B$ . Calculate the total area of the perforations per linear metre using the following equation :

$$A = (B N)/(n P)$$

where  $N$  is the total number of perforations per linear metre;  
 $n$  is the number of rows;  
 $P$  is the number of perforations marked on each row.

Out of the  $n P$  measured perforations, note the number of imperfect perforations. Let  $I_p$ , be this number. Calculate the total percentage of imperfect perforations,  $d$ , using the following equation:

$$d = 100 I_p/(n P)$$

### 6.3.6 Requirement on imperfect perforations

The quantity of imperfect perforations,  $d$ , in percent shall not exceed 10 % of the total number of measured perforations, i. e.  $I_p$  shall not exceed  $(n P)/10$ .

## 7 MECHANICAL CHARACTERISTICS

Necessary precaution shall be taken when using test pieces from coiled pipes.

### 7.1 Impact resistance

When tested in accordance with EN 1411 amended as in annex A of this Part, the following requirements shall be conformed to as applicable:

- a) If  $50 \leq DN \leq 200$ , the pipes shall comply with the four following requirements:

$$(X_f + X_p)/2 = H_{50} \geq 0.9 \text{ m}$$

$$H_{50sl} \geq 0.6 \text{ m}$$

$$H_{50pl} \geq 0.6 \text{ m}$$

$$H_{i \min} \geq 0.4 \text{ m}$$

- b) If  $DN > 200$ , the pipe shall conform with the four following requirements :

$$(X_f + X_p)/2 = H_{50} \geq 1.2 \text{ m}$$

$$H_{50sl} \geq 0.9 \text{ m}$$

$$H_{50pl} \geq 0.9 \text{ m}$$

$$H_{i \min} \geq 0.6 \text{ m}$$

where:  $X_f$  is the average of the dropping heights when failure occurred;  
 $X_p$  is the average of the dropping heights when test pieces passed;  
 $H_{50sl}$  designates the seam lines  $H_{50}$ ;  
 $H_{50pl}$  designates the perforation lines  $H_{50}$ ;  
 $H_{i \min}$  designates the minimum fall height without failure of the test.

## 7.2 Ring stiffness

### 7.2.1 Requirements

When tested in accordance with ISO 9969, the of ring stiffness  $S_o$  shall not be less than the applicable value given in Table 8.

**TABLE 8**  
Minimum ring stiffness values

Nominal diameter $DN/D_o$	Minimum ring stiffness (kN/m <sup>2</sup> )	
	Normal series	Special series (V-plough)
50	6.3	8
> 50 and $\leq 80$	4	8
$\geq 100$ and $\leq 125$	2	4
> 125 and $\leq 630$	2	No special series

### 7.2.2 Marking of ring stiffness series

All pipes shall have their corresponding series, i.e. “normal” or “special” series, clearly indicated on the label of the coil.

## 7.3 Creep ratio

When tested in accordance with ISO 9967, the creep ratio shall not be greater than 2.7.

## 7.4 Extensibility

This characteristic is not applicable for  $DN > 200$ .

When tested in accordance with EN [155 WI 124], no test piece shall have an elongation greater than 55 mm. If the first test piece has an elongation less than 45 mm, the result is considered to be satisfactory. If the first test piece has an elongation between 45 mm and 55 mm, the average of the elongations of this test piece with the two additional ones shall be less than 50 mm.

## 7.5 Brittle fracture test (rapid tensile test)

This characteristic is only applicable for pipes up to  $DN 80$  inclusive.

When tested in accordance with EN [155 WI 125], disregarding the first failure occurring within one nominal diameter, of the pipe being tested, from the anchoring devices, the result from three test pieces shall not include more than one failure. If one failure has occurred, the results from six further test pieces shall include no failures.

## 7.6 Stock conformity

To ensure stock conformity at delivery, manufacturers shall demonstrate compliance with the standard in accordance with Part 7.

## 8 MARKING

All pipe marking and labelling shall be in accordance with 5th draft of AHG 30. In addition, the following applies:

### 8.1 Pipe

Each pipe shall be clearly and indelibly marked at least every 6 m. The marking shall include the following information :

- a) the manufacturer's name and/or trade mark;
- b) the nominal diameter;
- c) the material (PVC-U);
- d) the year of manufacturing by punching;
- e) the "CE" mark and the European certification voluntary mark.

*NOTE: Trade mark, identification of manufacturing unit and complete manufacturing date are optional.*

### 8.2 Labelling

A coil label or equivalent device shall be attached to the pipe and include the following information:

- a) the manufacturer's name and/or trade mark;
- b) the identification of manufacturing site;
- c) the nominal diameter;
- d) the material (PVC-U);
- e) the nominal perforation width, in mm;
- f) the "L normal" or "L special" ("L" for land drainage, and either "normal" or "special" concerning the ring stiffness series as dealt in 7.2);
- g) pipe length or coil length, in m;
- h) the "CE" mark and the European certification voluntary mark;
- i) the manufacturing date (i. e. year, month and day: e.g. 92.06.05).

*NOTE : Trade marks and other quality marks are optional.*

### 8.3 Additional information

The pipe manufacturer shall declare a list of compatible fittings manufacturers and/or trade marks.



## NORMATIVE ANNEX A (concerning 7.1)

### Additional parameters for EN 1411 on staircase method

The test method given in EN 1411 shall be modified as follows, where the clause numbers given correspond to those in EN 1411.

#### 5.1 Preparation

Before cutting the test piece, the two seam lines shall be marked with different colours.

#### 5.2 Number

- a) Up to 10 pieces may be used for each part of the preliminary test (see 7.2).
- b) 32 test pieces are used for the main test (see 7.3).

### 6 CONDITIONING

Condition the test pieces for 15 min in a liquid bath or 60 min in air at  $0 \pm 1^\circ\text{C}$ .

#### 7.1 General

- a) The striker shall be type d90 with a mass of 1 kg.
- b) The circumferential orientation of the test piece in the V-block shall be in accordance with 7.2 and 7.3 (as modified by this annex).
- c) Failure

A blow is considered as a failure if any of the following characteristics occurs :

- the test piece breaks into two or more parts;
- fragmentation of the test piece occurs (see detail A in Figure A.1);
- the test piece shows at least one crack joining continuously any couple of perforations (see detail B in Figure A.1);
- a crack can be seen with the naked eye on the seam line and is longer than 5 mm.

Examples of these cases are shown in Figure A.1.

#### 7.2 Preliminary test procedure

The whole clause 7.2 is replaced by the following wording:

*NOTE: The purpose of the preliminary test is to obtain an indication of the  $H_{50}$  value and to identify the first test piece from which the result will be used in the main test (see 7.3). The preliminary test includes two series with up to 10 test pieces in each series: when testing in accordance with 7.2.3,*

*failures from each of the first two test pieces are considered indicative of an  $H_{50}$  less than the specified value and/or an excessive scatter of results.*

### 7.2.1

Set the drop height of the striker at 0.4 m.

### 7.2.2

After conditioning (see clause 6) for every test piece, within 10 s :

- in series one, impact the test pieces on a perforation line selected at random, determine and record whether or not the test piece fails and how it failed, and note the dropping height values.
- in series two, impact the test pieces alternately on seam line one and on seam line two.

### 7.2.3 Seam line

If the first test piece fails, test a second test piece, and if this also fails, then record the pipe as not having passed the impact test.

### 7.2.4

This clause in supporting standard is not applicable here.

### 7.2.5 Perforation line

If the first test piece fails, test a second test piece, and if this also fails, then record the pipe as not having passed the impact test.

### 7.2.6

Consider the dropping height at which the first test piece fails in each series to be the initial dropping height to be used in the corresponding series of the main test.

## 7.3 Main test

The main test is also divided into two series. Here, each series includes 16 test pieces.

In series one, ensure that each test piece is hit by the striker on a perforation line selected at random. In series two, ensure that the test pieces are hit by the striker alternately on seam line one and on seam line two.

Record the dropping height values for the test pieces and note whether or not the test piece failed.

Calculate the  $H_{50}$  failure level using the following equation :

$$H_{50} = (X_f + X_p)/2$$

where  $X_f$  is the average of the dropping heights when failure occurred;  
 $X_p$  is the average of the dropping heights when the test pieces passed.

Calculate two values of  $H_{50}$ , designated  $H_{50pl}$  and  $H_{50sl}$  as follows :

$H_{50pl}$  is the value derived from the 16 blows on the perforation lines;

$H_{50sl}$  is the value derived from the 16 blows on the seam lines.

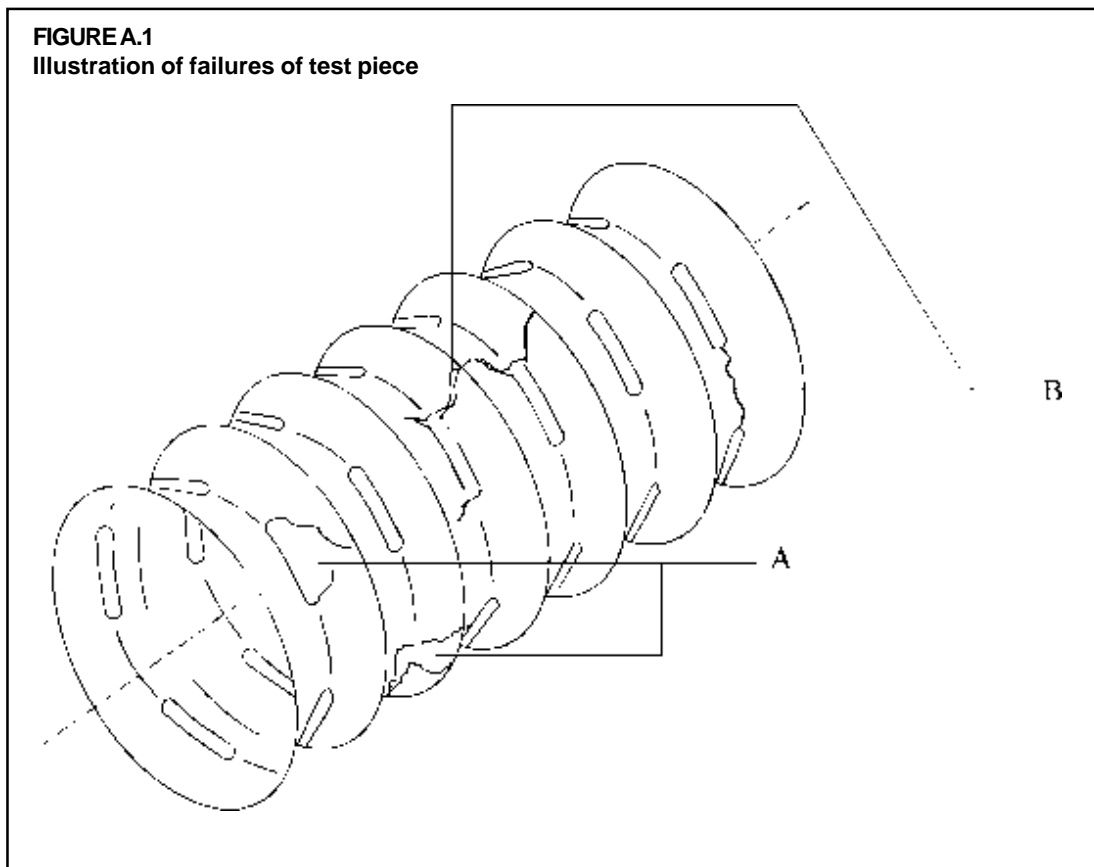

A blow is considered as a failure if :

- the test piece breaks into two or more parts ;
- fragmentation of the test piece occurs (detail A) ;
- the test piece shows at least one crack joining continuously any couple of perforations (detail B) ;
- a crack can be seen with the naked eye on the seam line and is longer than 5 mm.

## PART 3: FITTINGS

### 1 SCOPE

Part 3 specifies the requirements for PVC-U fittings. It also specifies the test parameters for the test methods referred to in this Part of this standard.

Polyethylene (PE) and polypropylene (PP) fittings may be used with PVC-U pipes.

### 2 NORMATIVE REFERENCES

- ISO 2507. Thermoplastic pipes and fittings - Vicat softening temperature - Test method and basic specification.  
ISO 2507-1. Vicat softening temperature - Part 1: General method.  
ISO 2507-2. Vicat softening temperature - Part 2: Special conditions for PVC-U, PVC-C and PVC-HI pipes.
- ISO 4439. PVC-U pipes and fittings - Determination and specification of density.
- CEN/TC 155 WI 127. Joint strength.

### 3 DEFINITIONS

For the purposes of this European standard, the following terms are illustrated in Fig. A.1 of annex A: coupler, T piece, Y junction, clip-on junctions, reducer, end cap and conic stopper, outlet pipe, vermin grating.

### 4 FITTINGS MATERIAL SPECIFICATION (FITTINGS MADE FROM PVC-U)

The material from which the fittings are made shall be PVC-U, and shall conform to the requirements specified in Part 1 of this standard. In addition, fittings made from PVC-U shall conform to the requirement of Table 1.

**TABLE 1**  
**Material requirement for fittings moulded from PVC-U**

Characteristic	Unit	Requirement	Test parameter	Test method
Vicat	°C	minimum 79	1 mm penetration 50 ± 1 N	TC 155 WI 043 (ISO 2507)

Fittings fabricated from pipe shall conform to the Vicat softening temperature required for pipe conforming to Part 2 of this standard, i.e. 77 °C.

### 5 GENERAL REQUIREMENTS

#### 5.1 Types of fittings

The types of fittings include the following :

- couplers;
- branches (T piece or Y junction);
- clip-on junctions;
- reducers;
- end caps and conic stoppers;
- outlet pipes.

## 5.2 Appearance

The internal and external surfaces of fittings shall be smooth, clean and free from grooving, blistering and any other surface irregularity likely to impair their performance. Fitting ends shall be cleanly cut and square with the axis of the fitting.

*NOTE: The fittings may be of any colour.*

## 6 GEOMETRICAL CHARACTERISTICS

### 6.1 Dimensions of fittings

#### 6.1.1 Diameter

The nominal diameter(s),  $DN$ , of a fitting shall correspond to and be designated by the nominal diameter(s) of the pipes conforming to Part 2 of this standard for which they are designed.

The maximum inside diameter,  $D_i$ , for fittings shall conform to the applicable value given in Table 2.

**TABLE 2**  
Requirements for maximum inside diameters

$DN$ of the pipe	$D_i$ max (mm)	$DN$ of the pipe	$D_i$ max (mm)
50	51.5	100	102.0
60	61.5	125	127.0
65	66.5	160	162.5
80	81.5	200	202.5

The difference between the maximum measured inside diameter of the fitting, in mm, and the nominal diameter (outside diameter for Scandinavia) of the pipe to which it is fitted shall be less than 1.5 mm up to and including  $DN$  80, less than 2.0 mm from  $DN > 80$  up to and including  $DN$  125, and 2.5 mm for  $DN > 125$ .

#### 6.1.2 Minimum wall thickness

The minimum wall thickness,  $e$ , of fittings shall be as follows :

- $e \geq 1.5$  mm for  $DN$  50 to  $DN$  80 inclusive;
- $e \geq 1.8$  mm for  $DN > 80$  and  $DN \leq 125$ ;
- $e \geq 2.5$  mm for  $DN$  larger than 125.

**NOTE:** Angles

*For branches, the preferred nominal angles are: 30°, 45°, 60°, 67.5°, 90°.*

**NOTE:** Inserting length

*Fittings should allow the junction between two different coils of pipes or between minor and major pipes. This should be made in such a way as to prevent soil entering the drains and also to prevent the end of the pipe forming the minor pipe protruding into the major pipe and obstructing flow. No fitting should cover or otherwise obstruct the perforations for a greater length than 300 mm for pipes up to and including  $DN$  125, and 400 mm for pipes over  $DN$  125 up to and including  $DN$  630.*

## 7 MECHANICAL CHARACTERISTICS

### 7.1 Assembly force and push through force test

This test is not required for *DN* larger than 200 mm.

When tested in accordance with EN [155 WI 127]-1, the forces, in N, shall conform to the applicable values given in the Table 3.

**TABLE 3**  
Requirements for assembly force and push-through force

<i>DN</i>	Assembly force	Push-through force
≥ 50 and ≤ 125	≤ 200 N	≥ 300 N
> 125 and ≤ 200	≤ 300 N	≥ 400 N

### 7.2 Resistance to separation (tensile force)

When tested in accordance with EN [155 WI 127]-2 and according the forces indicated in Table 4, the joint shall not part.

**TABLE 4**  
Required force for resistance to separation

<i>DN</i>	Applied force
≤ 65	150 N
65 < and ≤ 110	200 N
≥ 110	300 N

## 8 MARKING

### 8.1 Fitting

- a) Fittings shall be marked in a clear and durable way so that legibility is maintained when handled, stored and installed in accordance with Part 6 of this standard.

The marking may be printed or formed, integral on the fittings. The marking shall not damage the fitting.

The marking shall include the following information :

- the manufacturer's name and/or trade mark;
- the dimension (*DN*(s)) and the angle if relevant;
- the material;
- the "CE" mark and the European certification voluntary mark;
- the "L" letter.

### 8.2 Labelling

The label shall be fixed directly on the packaging without string.

The label shall include the following information :

- the manufacturer's name and/or trade mark;

- b) the identification of manufacturing site;
- c) the dimension ( $DN(s)$ ), and the angle, if relevant;
- d) the material;
- e) the other quality mark;
- f) the date of manufacturing: year and month;
- g) the “CE” mark and the European certification voluntary mark;
- h) the “L” letter.

All marks shall remain legible till the installation of the fittings.

If preferred, information on the packaging label may be mentioned on the fitting itself.

### **8.3 Additional information**

The pipe manufacturer shall declare a list of compatible fittings manufacturers and/or trade marks.

## ANNEX A (informative)

## Typical pipe junctions and connectors

**FIGURE A.1**  
**Typical fittings for sub-soil drainage**

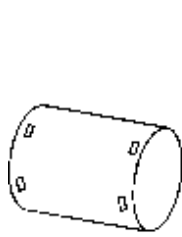

Coupler

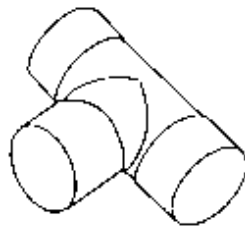

T piece



Y junction



Clip-on junctions

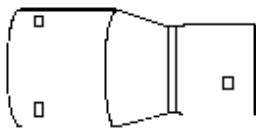
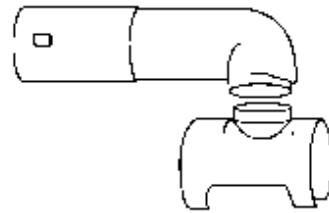

Reducer

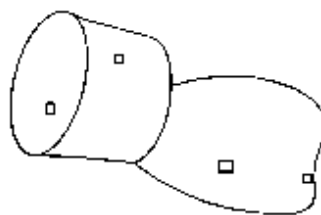

End cap



Conic stopper



Permanently fixed vermin grating

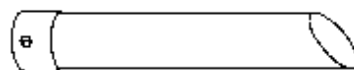

Outlet pipe



## PART 4: ENVELOPES

### 1 SCOPE

Part 4 specifies requirements applicable to envelopes used for wrapped pipes.

It also specifies the test parameters for the test methods referred to in this standard.

### 2 NORMATIVE REFERENCES

- ISO 554. Standard atmospheres for conditioning and/or testing – specifications.
- ISO 565. Test sieves - Metal wire cloth, perforated metal plate and electroformed sheet - Nominal sizes of openings.
- ISO 9 862. Geotextiles - Sampling and preparation of test specimens.
- ISO 9 863. Geotextiles - Determination of thickness at specified pressures.
- ISO 9 864. Geotextiles - Determination of mass per unit area.
- ISO 10 318. Geotextiles – Vocabulary.
- EN ISO 10 320. Geotextiles and geotextile-related products - Identification on site.
- EN ISO 12 956. Geotextiles and geotextile-related products – Determination of the characteristic opening size.

### 3 DEFINITIONS

For the purposes of this Part the definitions given in the other Parts of this European Standard apply together with the following:

**3.1 Geotextile:** A permeable, polymeric, synthetic or natural, textile material, in the form of manufactured sheet, which may be woven, non-woven or knitted, used in geotechnical and civil engineering applications.

*NOTE: The definition of “woven”, “non-woven” and “knitted” geotextile are included in ISO 10 318.*

*NOTE: The term “geotechnical” as mentioned hereabove includes the land drainage application.*

**3.2 Prewrapped loose material (PLM):** A permeable structure consisting of loose, randomly oriented yarns, fibres, filaments, grains, granules or beads, surrounding corrugated drain pipe, assembled within a permeable surround or retained in place by appropriate netting and used in drainage applications.

**3.3 Particle diameter limit  $d_m$ :** The diameter of soil particles at which  $m$  percent of the soil particles are, by dry weight, finer than that grain size.

**3.4 Pore size index  $O_{90}$ :** Opening size appertaining to the 90 percent particle size ( $d_{90}$ ) retained by the envelope as a result of sieving with specified sand fractions.

**3.5 Pore size index  $O_{95}$ :** Opening size appertaining to the 95 percent particle size ( $d_{95}$ ) retained by the envelope as a result of sieving with specific sand fractions.

## 4 SAMPLING AND CONDITIONING

### 4.1 Sampling

Cut five clean and undamaged pieces of pipe, each of at least 2.5 m long, from five selected coils. Avoid damage to or loosening of the envelope.

Mark the pipe sections for identification regarding :

- Trade-mark/manufacturer's name;
- Information supplied on the marking tape and optionally on the attached label;
- Coil number or other identification;
- Sampling date.

Dry moist sections at maximum 40 °C and at a relative humidity of maximum 50 percent until a constant mass is obtained.

If not being used for testing within 24 h, store the pipe sections free from dust, within a dry, dark atmosphere at ambient temperature and protected against chemical and physical damage.

### 4.2 Sample preparation

Carefully cut a length of  $1000 \pm 5$  mm from each of the wrapped drain pipes for thickness and mass determination.

Carefully cut another length of  $500 \pm 5$  mm from each of the wrapped drain pipes for pore size index determination.

For geotextiles only, carefully cut a length of  $1000 \pm 5$  mm from each of the wrapped drain pipes for wettability measurements.

Transfer the identification marking of each pipe section to the corresponding samples.

Store the samples free from dust within a dry, dark atmosphere at ambient temperature and protect them against chemical and physical damage until the tests are performed.

### 4.3 Conditioning

Condition the samples in accordance with ISO 554 for a period of 24 h.

## 5 SPECIFICATIONS

*NOTE: The material of which the envelopes are made is not specified but has to conform to the requirements of this standard.*

*NOTE: As test requirements for geotextiles are significantly different from those for PLM, the specifications need to be specific for each of these two categories, in most cases.*

### 5.1 General requirements

*NOTE: These requirements are applicable to geotextiles and PLM.*

### 5.1.1 Appearance

When inspected visually without magnification, the envelope shall be regular and no open spots shall be apparent.

*NOTE: The envelope material may be of any colour.*

## 5.2 Specifications for geotextiles

### 5.2.1 Thickness

When measured in accordance with ISO 9 863, the nominal thickness shall not deviate more than 10 percent from that declared by the manufacturer.

### 5.2.2 Mass per unit area

When measured in accordance with ISO 9 864, the mass per unit area shall not deviate more than 10 percent from that declared by the manufacturer.

### 5.2.3 Pore size index

When measured in accordance with EN ISO 12 956, the opening size shall not deviate more than 30 percent from that declared by the filter manufacturer.

### 5.2.4 Wettability

When measured in accordance with annex A of this Part, the water head shall not exceed 5 mm and the wet area shall be 100 percent of the surface of the ten test pieces.

## 5.3 Specifications for PLM

### 5.3.1 Thickness requirements

When measured in accordance with the methods described in annex B, the requirements shall be as follows.

#### a) Minimum thickness

The minimum thickness requirement shall depend on the material used as given in Table 1.

**TABLE 1**

**Minimum thickness  $e_{min}$ , in mm, requirement for prewrapped loose materials**

Synthetic		Organic	
Fibrous	Granular	Fibrous	Granular
3.0	8.0	4.0	8.0

#### b) Mean average thickness requirement

The mean average thickness of each test piece should not deviate by more than 25 % from that declared by the manufacturer.

### 5.3.2 Mass per unit area

When determined in accordance with annex C, individual measurements shall not deviate by more than 25 percent from the manufacturer's declared mass per unit area.

### 5.3.3 Pore size index

When determined in accordance with annex D, all individual measurements of the  $O_{90}$  size shall lie between the limits given for the class represented by the marking.

Two classes of PLM, depending on the pore size index  $O_{90}$ , are accepted :

PLM-F (F: fine):  $300 \mu\text{m} \leq O_{90} < 600 \mu\text{m}$ ;

PLM-S (S: standard):  $600 \mu\text{m} \leq O_{90} \leq 1100 \mu\text{m}$ .

## 6 MARKING

For geotextiles, the required information (see Table 2) shall, if possible, be printed on the envelope, at least on both ends of the coil.

For other geotextiles and for PLM, where marking on the envelope is not appropriate, marking shall be done on an adhesive tape, at least on both ends of the coil - unless it is not feasible to print all the required information on the marking tape, in which case the information may be given on a label attached to the pipe or on the geotextile itself. At least the date of manufacturing and wrapping should remain after installation on the filtered pipe.

The marking shall include the information required by Table 2.

**TABLE 2**  
**Minimum marking requirements**

Information	Geotextile	PLM
Name of wrapping company	√	√
Raw material of filter	√	√
Type of filter	WG: woven geotextile KG: knitted geotextile NG: non-woven geotextile	PLM
Thickness	optional	√
Mass per unit area	optional	√
Pore size index	optional	F or S (see 5.3.3)
Wrapping date	(yy/mm/dd)	(yy/mm/dd)

The marking shall be weather resistant and legible after installation.

## ANNEX A (normative)

### Determination of the wettability of a geotextile

#### A.1 Definitions

Wettability: Capacity of a dry geotextile to have a low initial resistance to water penetration.

#### A.2 Principle

The resistance of a geotextile to the passage of water is measured by :

- the maximum hydraulic pressure ( $h$ ) needed to pass the geotextile perpendicularly to its plane.
- the percentage of the surface area ( $s$ ) of passage of the water through the geotextile. This surface area is the outer surface area of the water.

A plane test piece of a geotextile is progressively subjected to an increasing water pressure.

The maximum hydraulic pressure needed for the water to pass completely through the test piece is noted as well as the wetted surface.

#### A.3 Apparatus

**A.3.1 A measuring cylinder**, made of a transparent material, of inside diameter at least equal to 80 mm, with a base plate comprising a rigid mesh which can support a test piece. A water-tight seal, comprising a silicone mastic or elastomeric seal, is incorporated between the test piece and the adjacent rim of the cylinder.

**A.3.2 A water supply**, comprising water in a container from which an increasing water pressure can be applied. The device is such that the water pressure is applied vertically, either from the top downwards, or from the bottom upwards. The water used for the test may be coloured with a solution of 1 per 1000 fluorescent dye type  $C_{20}H_{10}Na_2O_5$ .

**A.3.3 A pressure measuring device**, comprising one of the following forms (see Figures A.1 and A.2):

- a) When the water flows from the top downwards, the pressure can be measured by the water head in the cylinder.
- b) When the water flows from the bottom upwards, the pressure can be measured with a dynamometric cell.

*NOTE: Recommended apparatus (wettabilimeter). Supply from the top downwards is easy to build (see Figure A.3), but its design needs to take into account the risk of clogging by fluorescein. In order to clean it regularly, it is necessary to be able to plug in/out the stainless pipe insert and to dismantle the bottom part of both of the container and the measuring cylinder in a convenient way (see Figure A.4-a and Figure A.4-b).*

#### A.3.4 Thickness determination

Means for determining the thickness of a test piece to within 0.01 mm are specified in ISO 9 863.

**FIGURE A.1**  
Apparatus with water supply from the top downwards

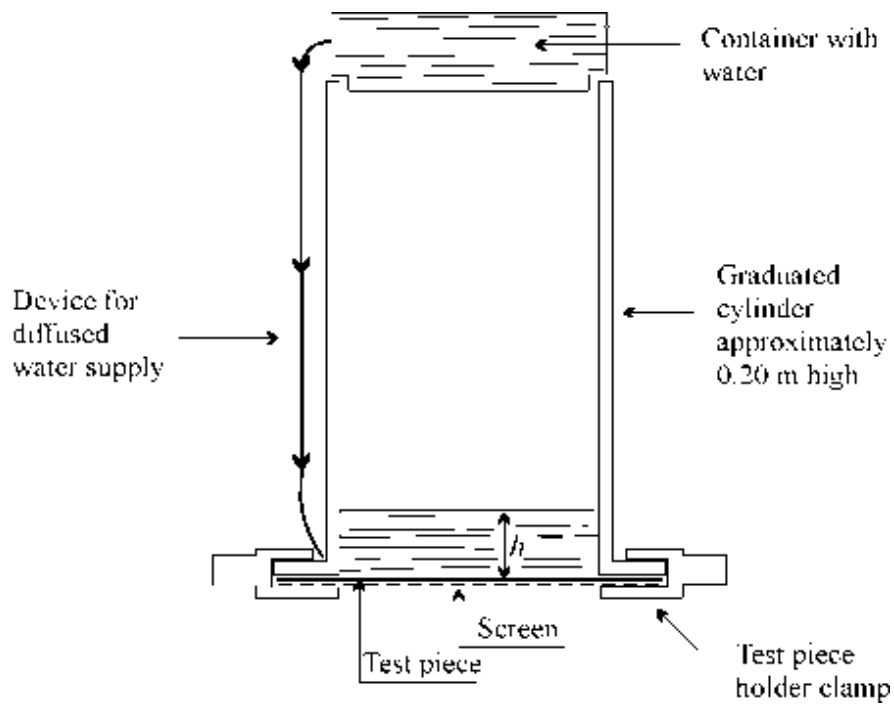

**FIGURE A.2**  
Apparatus with water supply from the bottom upwards

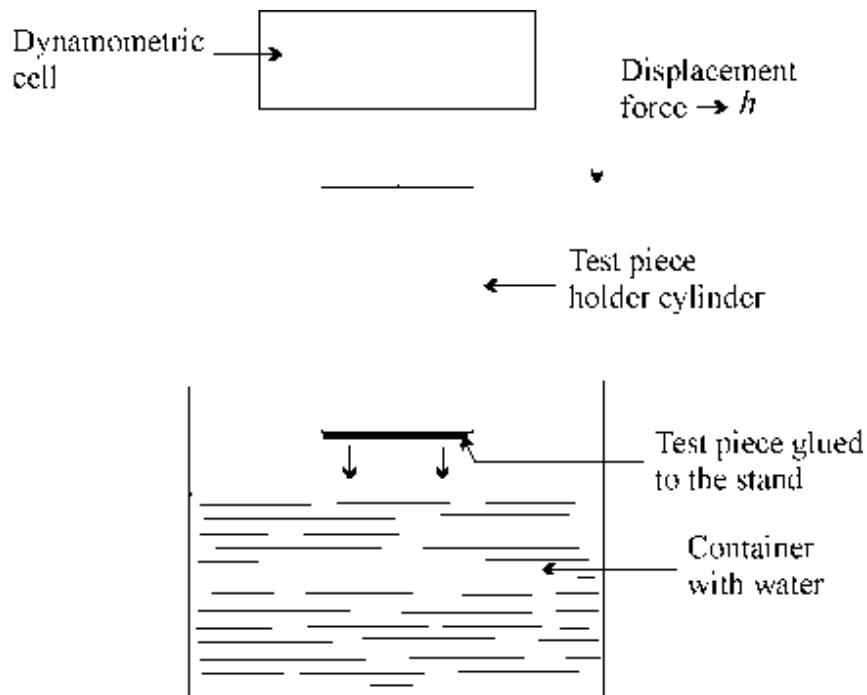

**FIGURE A.3**  
**Wettabilimeter: general sketch**

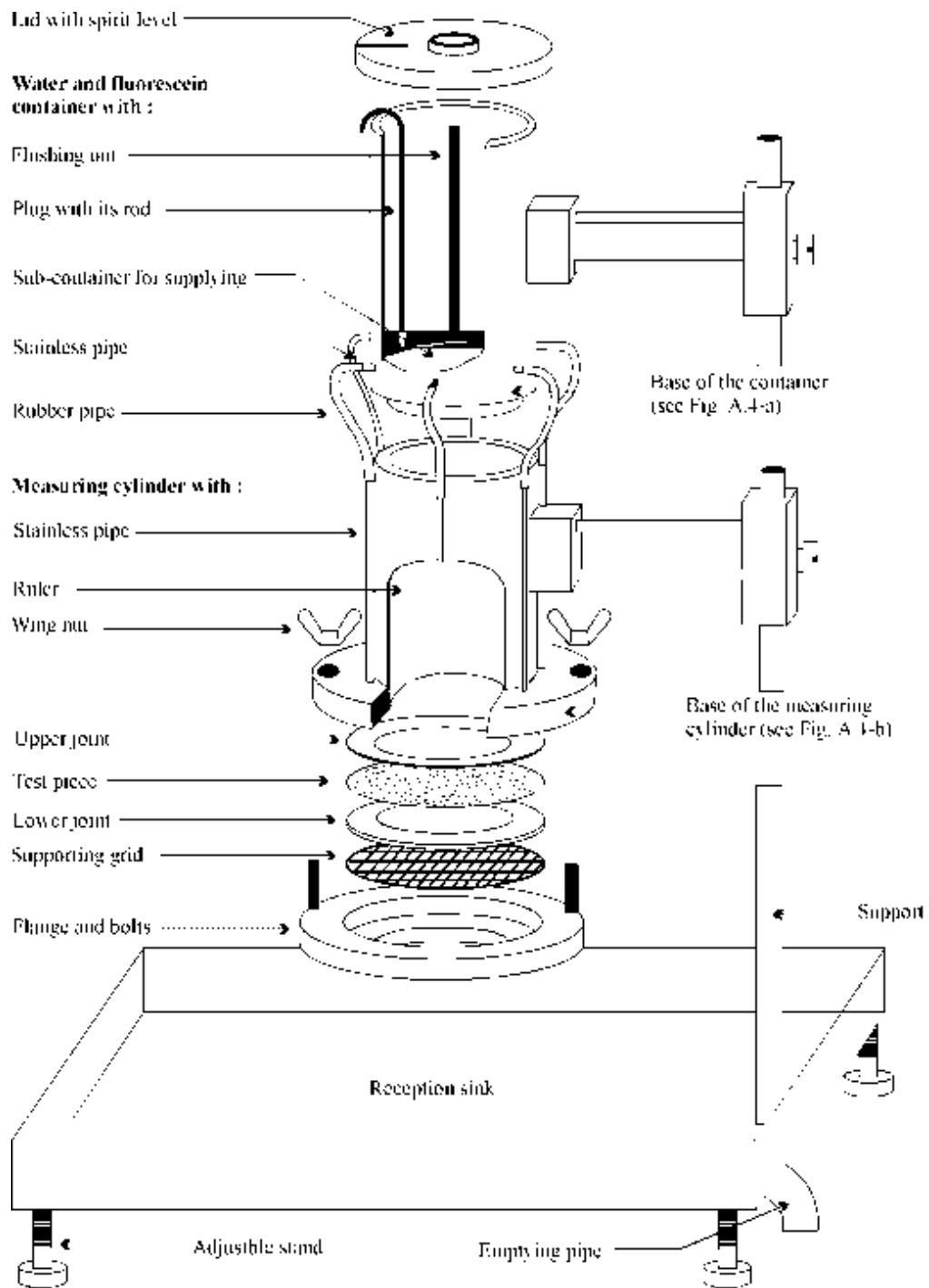

**FIGURE A.4a**  
Base of the container

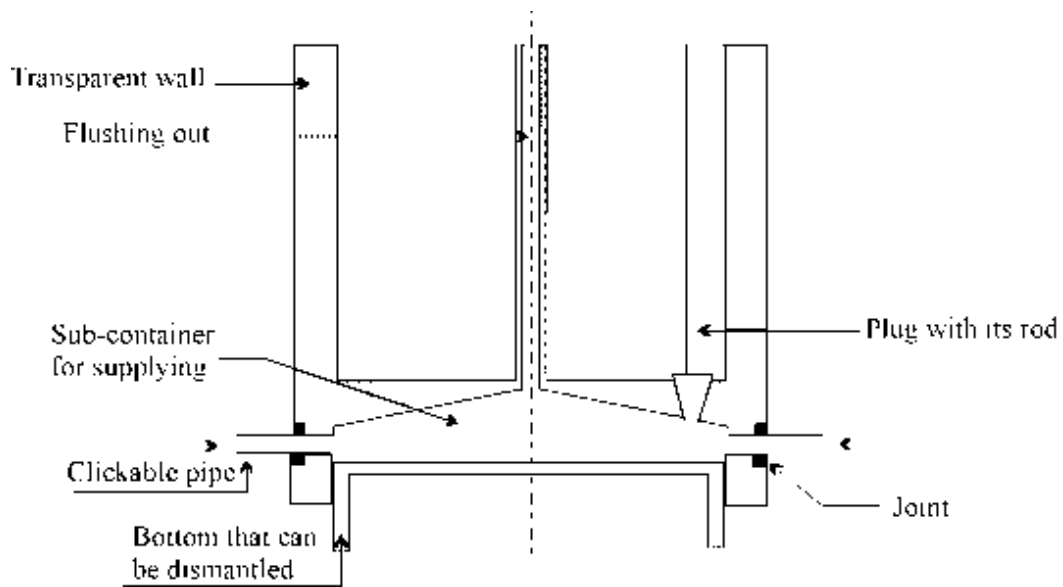

**FIGURE A.4b**  
Base of the measuring cylinder

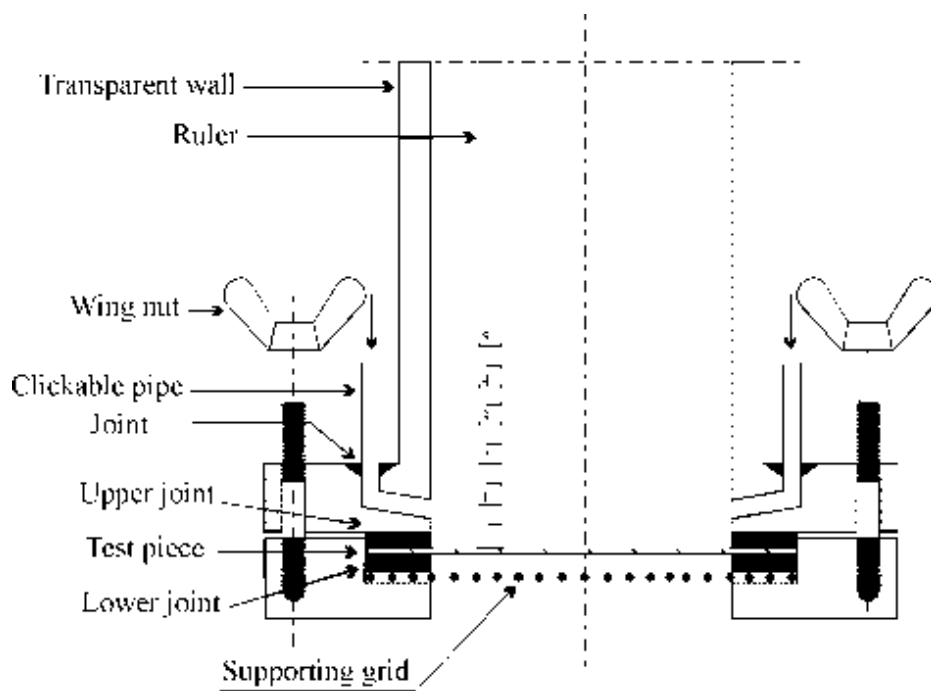



### **A.3.5 Mass per unit area determination**

Means for determining the mass per unit area of a test piece to within 0.01 g/m<sup>2</sup> are specified in ISO 9 864.

## **A.4 Test piece**

### **A.4.1 Preparation**

The test piece shall comprise plane panel cut from a sample of the geotextile to fit across the end of a cylinder (A.3.1) having an inside diameter of at least 80 mm.

*NOTE: The geotextile should be handled as infrequently as possible and not folded in order to prevent disturbing the surface structure.*

### **A.4.2 Sampling**

At least ten test pieces shall be cut from positions regularly distributed along and across a sample at least 1 m long taken at random from the geotextile material.

*NOTE: It is recommended that additional test pieces are obtained to replace any which may be discarded in the event of leakage past their edge while under test.*

## **A.5 Conditioning**

Maintain each test piece for 24 h in one of the testing atmospheres described in ISO 554.

Keep the test piece in a flat position without any load.

## **A.6 Procedure**

Mount and seal the test piece in position on the appropriate end of the cylinder (A.3.1). After verifying that the measuring cylinder is vertical, increase the water pressure at a speed of the order of 10 mm/min. Record the maximum water height attained to within 1 mm.

During the test, observe the passage of the water through the test piece, and reject as unsatisfactory any test in which there is a passage at the joint. Repeat such tests using a fresh test piece.

Measure the effective area(s) of passage of the water on the outer surface area of the test piece, using any suitable method to determine the outlines of the wetted area(s).

*NOTE: Observation under the light of an ultra-violet lamp is recommended.*

Measure, in mm<sup>2</sup>, the areas of passage, to within 1 %.

When the water head attains 100 mm, measure the time taken by water to penetrate.

### **A.7 Results**

For each test piece, record the maximum hydraulic pressure, to within 1 mm, and the percentage of the area of passage to the total area of the test piece, to within 1 percent of variation.

Calculate the arithmetic mean of the values obtained and the coefficient of variation. For the valid test pieces used, i.e. excluding any rejected in accordance with A.6, calculate the mean mass per unit area and the mean thickness.

### **A.8 Test report**

The test report shall include at least the following information :

- a) the number and date of this standard ;
- b) the identification of the geotextile according to EN ISO 10 320 ;
- c) the mass per unit area of each test piece and the mean mass per unit area of the test pieces ;
- d) the nominal thickness adjacent to the test piece and the mean thickness of the test pieces ;
- e) details of apparatus used, including a diagram ;
- f) the area of the exposed test pieces ;
- g) the tabulated results of the experimental data and calculations ;
- h) the mean water head resistance to water penetration and the maximum water head resistance value ;
- i) the mean and maximum time taken by water to penetrate after 100 mm water head has been attained ;
- j) the mean percentage of the wetted area of the exposed test pieces and the maximum percentage of the wetted area of the exposed test pieces.

## ANNEX B (normative)

## Determination of the thickness of prewrapped loose material (PLM)

## B.1 Principle

For minimum thickness, the smallest distance among those run by needles going through the prewrapped loose material is taken. For mean thickness, both wrapped pipe and uncovered pipe diameter are measured by a tape at a specified pressure.

## B.2 Minimum thickness

Determination of the minimum thickness,  $e_{min}$ , of the envelope shall be done with a measuring device, as shown in Figure B.1, on the five samples with a length of 1000 mm.

The measuring device shall have a measurement range up to 20 mm with a reading accuracy of 0.1 mm.

Visually inspect the pipe sections to assess the minimum thickness.

Put the foot on a hard, flat surface and adjust the gauge to zero.

Press (by hand) the pins through the envelope till at least one pin reaches the pipe wall.

Read the minimum thickness and round off the measured value to the nearest 0.1 mm.

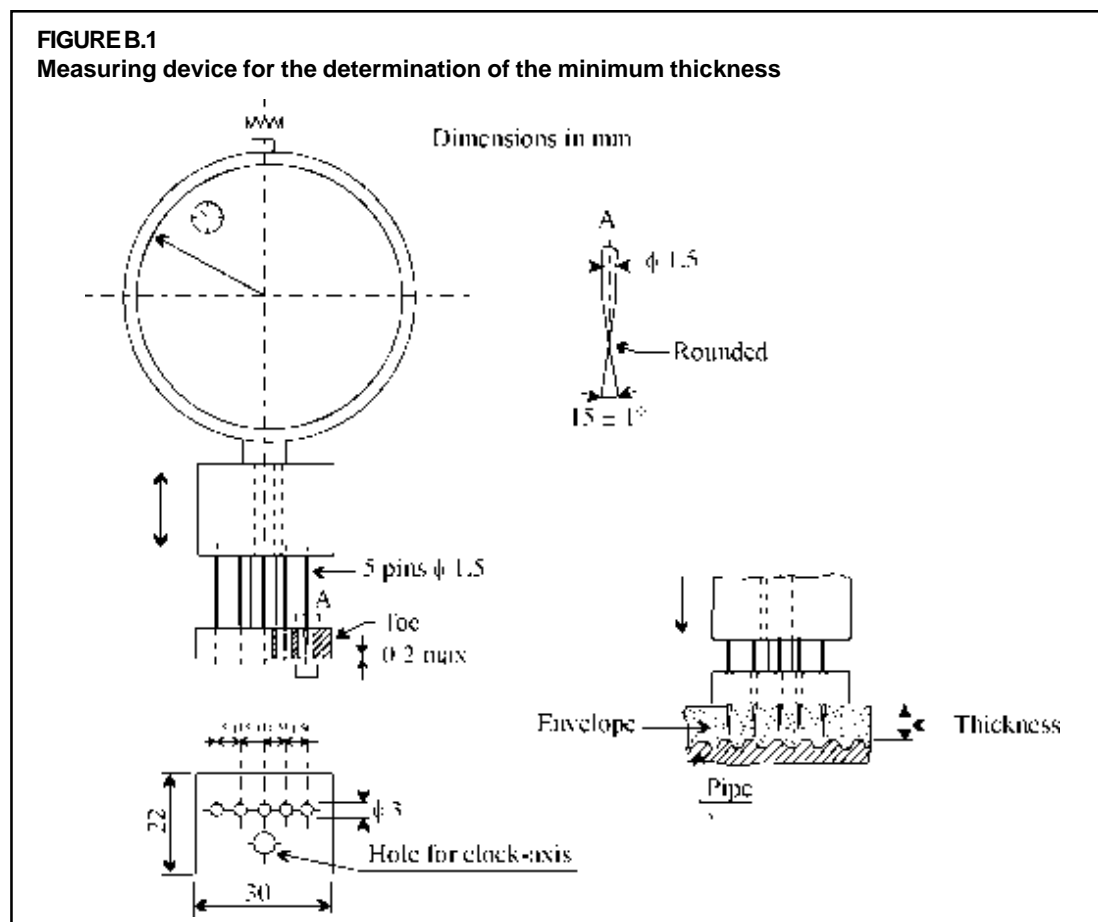

### B.3 Mean average thickness

#### B.3.1 Apparatus

Determination of the mean average thickness  $e$  of the envelope on the five samples with a length of 1000 mm, i. e. in fact the test piece, requires a measuring tape which is subjected to a load of  $1.75 \pm 0.25$  N for a tape width of 8 mm; the load shall be  $2.50 \pm 0.25$  N for a tape width of 16 mm; for tape widths between 8 mm and 16 mm, the required load shall be linear interpolated between 1.75 N and 2.50 N.

#### B.3.2 Procedure

Determine either the outside circumference or directly the outside diameter of pipe plus envelope four times on equally distributed places of the test piece with a measuring tape to an accuracy of 0.1 mm.

Carefully remove the envelopes and put them aside for determination of mass (see annex C.2).

Repeat the procedure to determine either the outside circumference or outside diameter of the pipe.

#### B.3.3 Calculation

Calculate either the average outside circumferences  $P_o$  and  $P_m$  or the average outside diameter  $D_o$  and  $D_m$  from the four measurements on the test piece and round off the result to the nearest 0.1 mm.

Calculate the mean average thickness  $e$  of the test piece using the following equation:

$$e = (P_o - P_m)/2\pi = (D_o - D_m)/2$$

where:  $e$  is the mean average thickness of the wrapping material (mm) ;  
 $P_o$  is the average outside circumference of pipe and envelope (mm) ;  
 $P_m$  is the average outside pipe circumference (mm) ;  
 $\pi = 3.142$  ;  
 $D_o$  is the average outside diameter of pipe and envelope (mm) ;  
 $D_m$  is the average outside pipe diameter (mm).

### B.4 Test report

The test report shall include at least the following information :

- a) the number and date of this standard ;
- b) the conditioning atmosphere and the time of relaxation ;
- c) the minimum and mean average thickness of each test piece ;
- d) the coefficient of variation at specified pressure ;
- e) deviation of the mean average thickness of each test piece from the manufacturer's thickness ;
- f) if required, the experimental data and calculations of the minimum and mean average thickness of each specimen can be tabulated.

## ANNEX C (normative)

### Determination of the mass per unit area of prewrapped loose material (PLM)

#### C.1 Principle

A specified area of wrapping material is weighed to assess the average quantity of envelope material around the pipe.

#### C.2 Procedure

The mass per unit area is calculated from weighing the prewrapped loose material of the test piece with a length of 1000 mm after removal of the wrapping twines for fibrous envelopes and the surround for granular envelopes.

Weigh separately each removed envelope of the five test pieces to an accuracy of 0.1 g after the thickness measurements have been performed according to annex B.

The obtained mass is the mass per linear meter of pipe  $m_l$  and is expressed in g/m.

#### C.3 Calculation of the results

Calculate the corresponding mass per unit area, with its mean average thickness  $e$ , using the following equation:

$$m = 1000 m_l / [\pi (D_m + e)]$$

with  $D_m = P_m / \pi =$  outside pipe diameter in mm ;

$e =$  mean average thickness in mm as determined according to B.3.

$D_m$  and  $e$  are given with an accuracy of 0.1 mm;  $m$  is expressed in g/m<sup>2</sup> and calculated to the nearest 1 g/m<sup>2</sup>.

#### C.4 Test report

The test report shall include at least the following information :

- a) the number and date of this standard ;
- b) the conditioning atmosphere and the time of relaxation ;
- c) if required, the experimental data and calculations of the mass per unit area of each specimen can be calculated ;
- d) the mass per unit area of each specimen ;
- e) deviation of the mass per unit area of each specimen from the manufacturer's mass.

## ANNEX D (normative)

### Prewrapped loose material: determination of the pore size index

#### D.1 Principle

A test piece disc of the envelope is taken, fixed in a frame and placed horizontally on a sieving apparatus. An amount of a specific sand fraction is poured on the test piece. A vertical vibration with a specific frequency and amplitude is applied to the test piece for a specific time. The amount of sand remaining on and in the test piece reflects the largest pore sizes.

#### D.2 Material

##### D.2.1 Sand fractions

The sand fractions shall be composed by dry sieving sand according to ISO 563 using a stack of ISO-sieves selected from the R20-series of ISO 565 with mesh sizes given by the fraction limits in Table D.1.

**TABLE D.1**  
Fraction limits and average particle diameter of the sand fractions

Fraction limits ( $\mu\text{m}$ )		Average particle diameter ( $\mu\text{m}$ )
$d_{min}$	$d_{max}$	$d_m$
90	125	108
125	160	143
160	200	180
200	250	225
250	315	283
315	400	358
400	500	450
500	630	565
630	800	715
800	1 000	900
1 000	1 250	1 125
1 250	1 400	1 325

#### D.3 Apparatus

##### D.3.1 Cutting die

A circular metal cutting die with internal diameter of  $135 \pm 0.1$  mm shall be used to obtain the test pieces from the sample.

##### D.3.2 Sieve apparatus

The sieve apparatus shall generate a vertical vibration with an amplitude of 0.75 mm and a frequency of 50 Hz.

##### D.3.3 Test piece holder

The test piece holder shall be composed of the following elements (see figure D.1) :

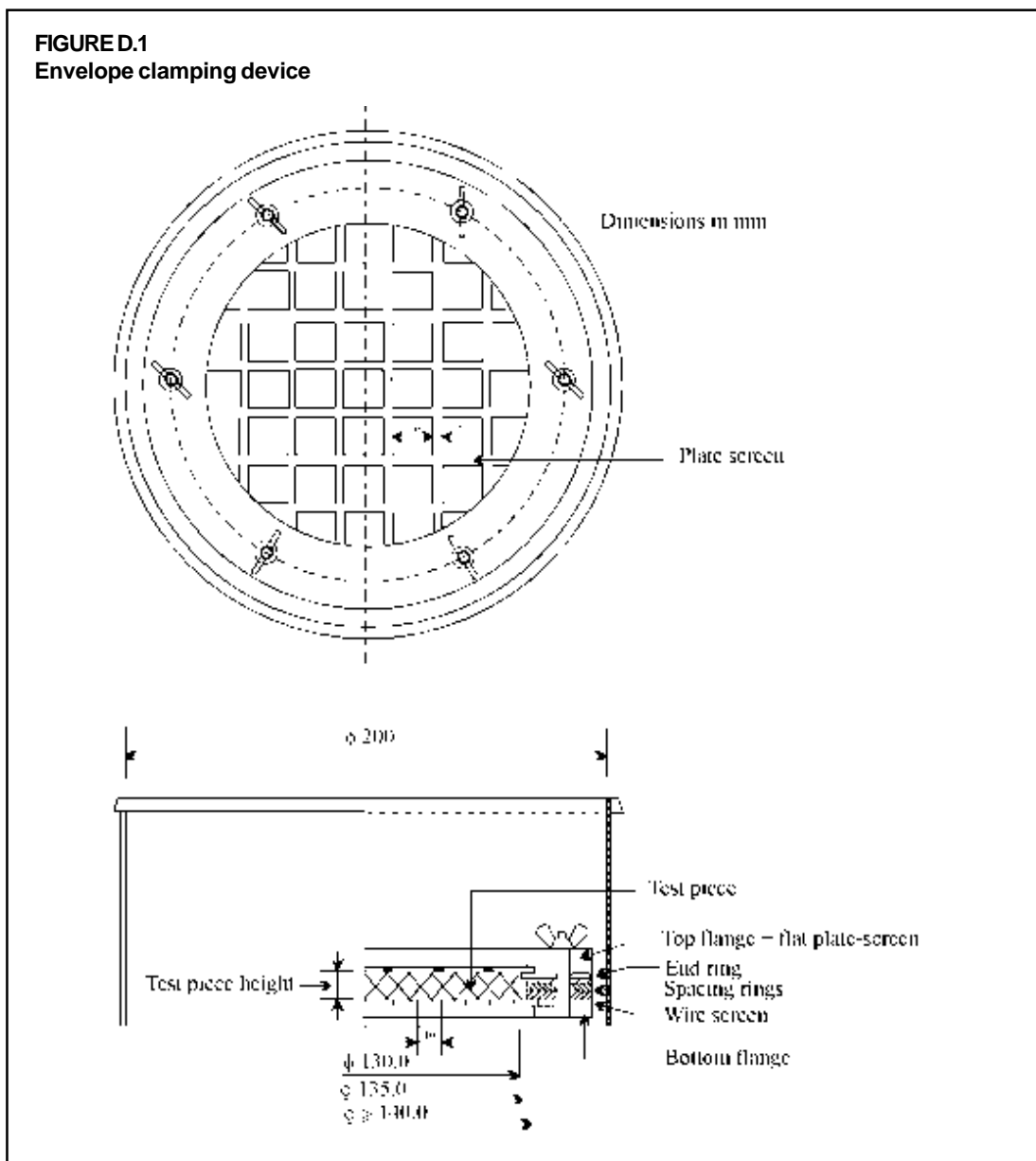

- wire screen with a mesh size of 10 mm ;
- a bottom flange with an internal diameter of at least 140 mm ;
- a number of flat, rigid and stackable spacer rings with internal diameter of  $135 \pm 0.1$  mm, increasing in thickness with steps of 0.2 mm and one rigid end ring with an internal diameter of  $130 \pm 0.1$  mm and a thickness of 1.0 mm ;
- a top flange having an internal diameter of  $135 \pm 0.1$  mm and a height of at least 10 mm, with a flat plate-screen attached at the bottom side with a mesh size of 16 mm.

#### D.3.4 Bottom plate and weight

Pore size index assessment requires the test piece height under load. Therefore a steel bottom plate weight with a combined mass of  $9.3 \pm 0.1$  kg and a combined total height  $h_p$ , measured to an accuracy of 0.1 mm are required (Figure D.2). The stiff, flat bottom plate has an outside diameter of  $135 \pm 0.1$  mm and a thickness of  $4 \pm 0.1$  mm.

**FIGURE D.2**  
Bottom plate and weight

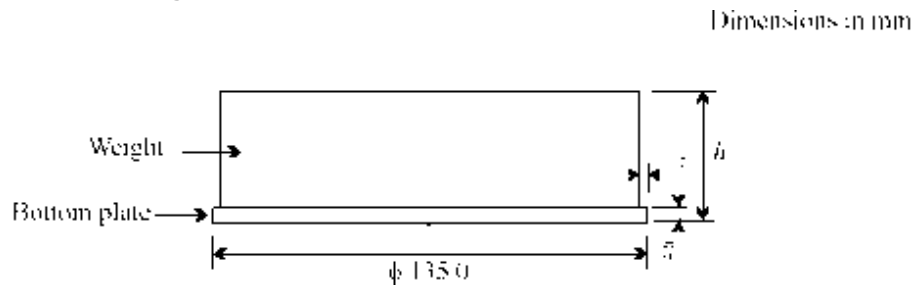

**FIGURE D.3**  
Tray

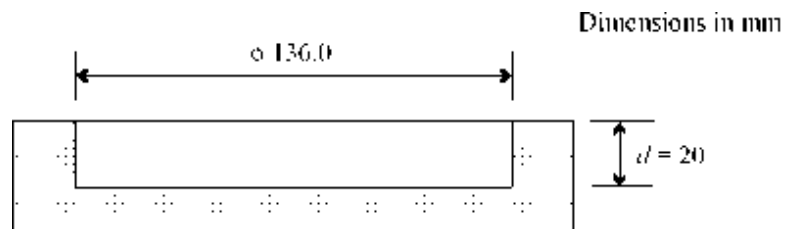

**FIGURE D.4**  
Thickness determination under load of a test piece of fibrous envelopes

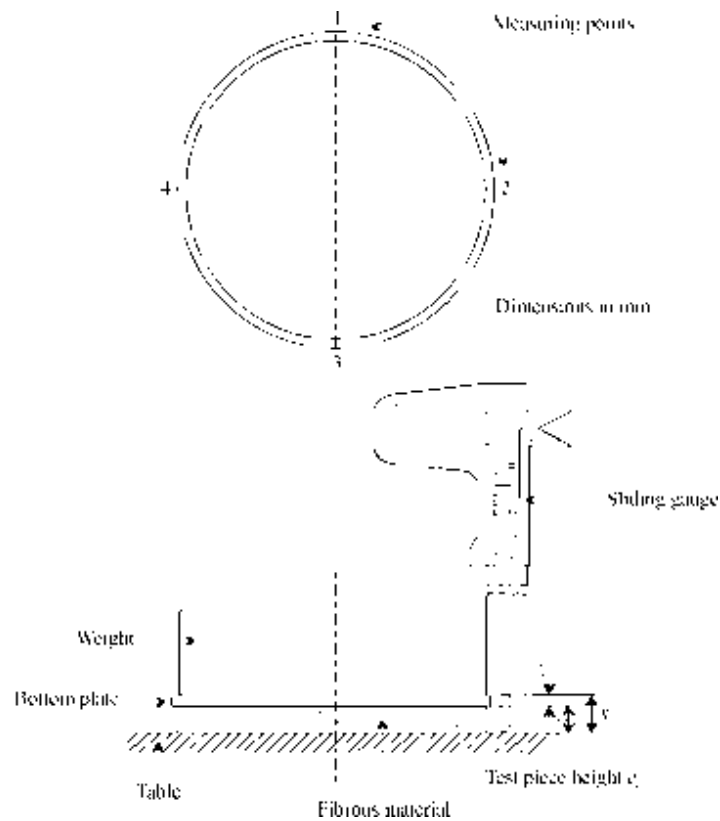



Additionally granular envelopes require a tray with a diameter of  $136 \pm 0.1$  mm and a minimum depth  $L$  of 20 mm measured to an accuracy of 0.1 mm (Figure D.3).

#### **D.4 Procedure for fibrous envelopes**

##### **D.4.2 Selection of spacer rings**

Carefully remove the envelope from the samples with length of 500 mm, starting at the seam. If the seam can not be found use a pair of scissors.

Cut a test piece from the removed envelope with the cutting die and a sledgehammer.

Place the test piece on a flat surface and put the bottom plate and weight on it.

*NOTE: This force approximates to the load exerted on the envelope due to soil load.*

After  $600 \pm 15$  s, determine with a sliding gauge, as shown in Figure D.4, the thickness  $x$  to an accuracy of 0.1 mm.

Repeat this measurement at 3 other locations and calculate the average value  $x_m$  to an accuracy of 0.1 mm.

Calculate the test piece height  $e_l$  in reducing  $x_m$  with 4.0 mm.

Select a stack of spacer rings (including the end ring) corresponding to the test piece height  $e_l$ . Spacer rings and the sample must closely fit.

Fit the test piece tensionless and flat in the test piece holder (see Figure D.1), the contact side with the drain pipe directed downwards.

Put the top flange in place and mount the test piece holder on the collecting tray of the sieve apparatus.

##### **D.4.3 Sieving procedure**

Choose a sand fraction  $d_m$  closest to the assumed  $O_{90}$ .

Weigh 50 g of the chosen sand fraction with an accuracy of 0.01 g.

Ensure that the sieve apparatus is level.

Pour the sand on the test piece, ensuring that during sieving the sand spreads evenly on the test piece. Close the lid of the sieve apparatus.

Activate sieve apparatus during  $300 \pm 2$  s.

Remove the test piece holder from the sieve apparatus, ensuring that the sand on top and inside the test piece does not fall into the collecting tray.

Weigh the sand of the collecting tray with an accuracy of 0.01 g.

Remove the sand on top and inside the test piece by turning and shaking the test piece holder. In total at least 49 g of sand shall be recovered.

Choose the sand fraction for the next sieve analysis based on the first sieve result.

Repeat the sieve procedure.

Determine the pore size index according to D.4.4.

If necessary, repeat the sieve procedure, with a chosen sand fraction which includes the expected pore size index.

Determine, according to this procedure, the pore size index of the other four test pieces.

Each sand fraction shall be used only five times.

#### D.4.4 Calculation of results

For each test piece, plot the percentage of each fraction that passed the test piece on a diagram against the mean fraction diameter with the latter on a logarithmic axis and the percentage on a probability axis. Manually fit and draw a straight line through the plotted points. The intersection of this straight line with the 10 percent line marks the pore size  $O_{90}$  or the pore size index. The pore size index is expressed in  $\mu\text{m}$  and rounded off to the nearest 5  $\mu\text{m}$ .

### D.5 Procedure for granular filters

#### D.5.1 Selection of spacer rings

*NOTE: Contrary to the fibrous prewrapped envelopes, determination of the pore size index of a granular envelope is not possible. Procedures for thickness under load and hence test piece preparation are different.*

Carefully remove the surround from the sample with a length of 500 mm and put each amount aside for later use.

Collect the granular material in a dish.

*NOTE: The dish is preferably made of glass.*

Weigh the collected granules of the sample with an accuracy of 0.01 g and determine the mass  $G_m$  in g/m.

Determine the mass  $G_l$  in g using the following equations :

$$G_l = (A_l/A) G_m = 4.56 G_m / (D_m + e)$$

where:  $G_l$  is the mass of granular material to determine test piece height for the sieve test (g) ;

$A_l = \pi 135^2/4$ ; mean surface area of each of the four test pieces ( $\text{mm}^2$ ) ;  
 $A = \pi (D_m + e)1000$ ; mean surface area of pipe plus envelope for one meter length ( $\text{mm}^2$ );  
 $G_m$  is the mass of granular material per meter of pipe length (g/m) ;  
 $e$  is the mean average envelope thickness of the pipe sample (mm) according to B.3.

$G_l$  is expressed in g and calculated to the nearest 1 g.

Collect an amount of granular material in the tray equal to the mass  $G_l \pm 0.1$  g.

Spread the granular material evenly in the tray.

Use the cutting die to cut a disc out of the surround and put it on top of the granular material.

Place bottom plate and load on the test piece in the tray. After  $300 \pm 15$  s, determine the sliding gauge reading  $x$  with an accuracy of 0.1 mm at four places as indicated in Figure D.5 and calculate the average value  $x_m$ .

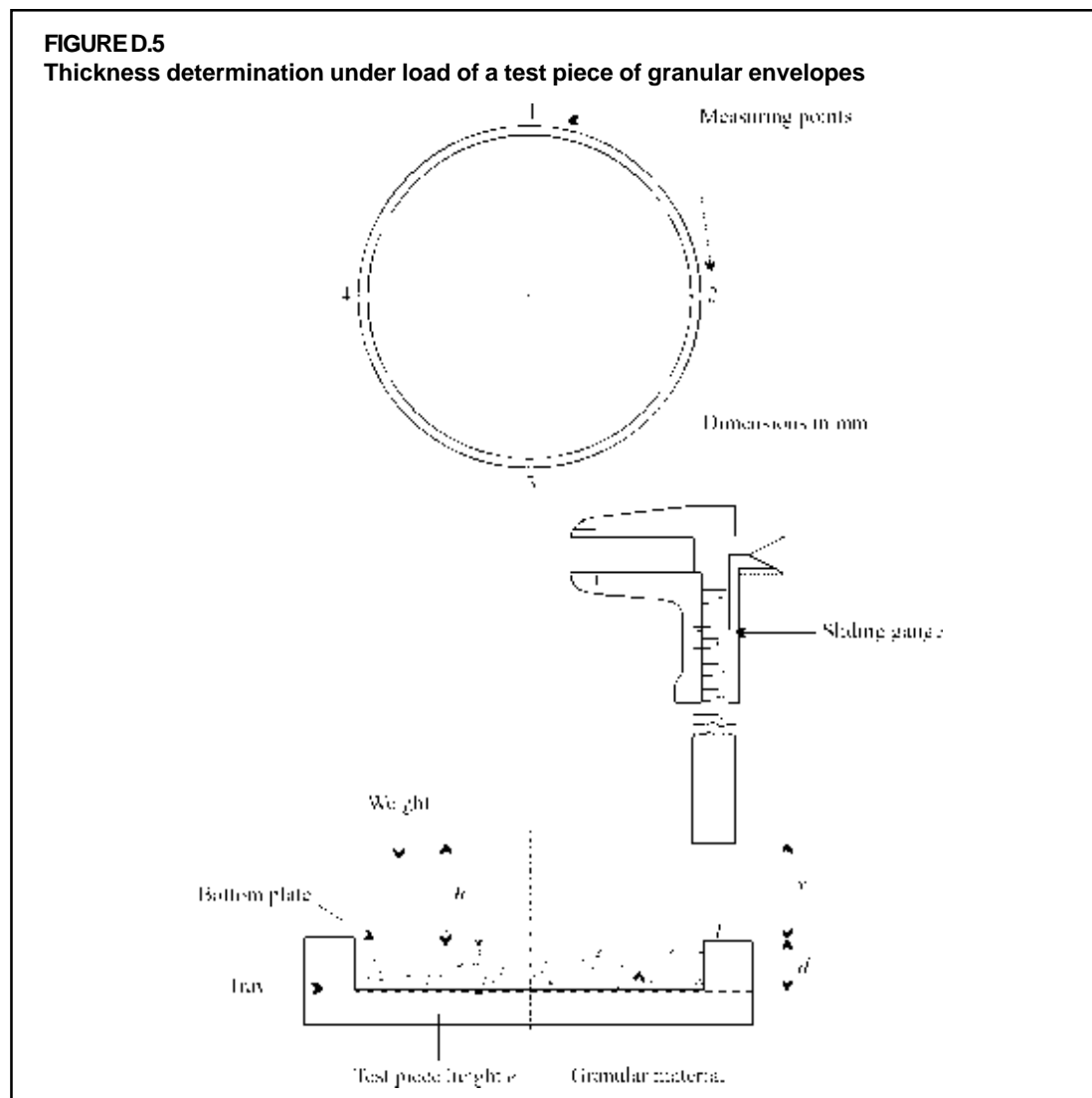

Calculate the test piece height under load  $e_l$  using the following equation :

$$e_l = d + x_m - h_l$$

with  $d$  the depth of the tray ;  
 $x_m$  the average sliding gauge reading ;  
 $h_l$  the height of the bottom plate plus weight.

All values are expressed in mm and determined with an accuracy of 0.1 mm.

Select a stack of spacer rings (including the end ring) corresponding to the test piece height  $e_l$ .

Bring the granular material from the tray into the test piece holder and spread evenly.

Put the surround on top of the granular material.

Put the upper flange in place and put the test piece holder on the collecting tray of the sieving apparatus.

#### **D.5.2 Sieving procedure**

The procedure for fibrous envelopes as given in D.4.3 is applicable.

#### **D.5.3 Calculation of the results**

The determination of results is similar as with fibrous envelopes according to D.4.4.

#### **D.5.4 Report**

The test report shall include at least the following information :

- a) the number and date of this standard ;
- b) details of apparatus including a diagram, if required ;
- c) the tabulated values of the used granular material. If required, the experimental data and calculations of the amount of retained granular material can be tabulated ;
- d) the pore size index ( $O_{90}$ ) of each specimen.

#### **Bibliography**

- EN ISO 12 956. 1999 Geotextiles and geotextile related products - Determination of the opening size.
- EN 964-1. 1994. Geotextiles and geotextile-related products - Determination of thickness at specified pressures - Part 1: Single layers.
- EN 965. 1994. Geotextiles and geotextile-related products - Determination of mass per unit area.

## PART 5: FITNESS FOR PURPOSE OF THE SYSTEM

### 1 SCOPE

Part 5 includes tests which relates to the reciprocal adaptability between fittings and pipe. If these latter are sold together the reciprocal adaptability is under the mutual responsibility of the fittings manufacturer and the pipe manufacturers. If they are sold separately, the installer and his partners should make sure that they comply with this standard.

### 2 NORMATIVE REFERENCES

No normative references.

### 3 ASSEMBLY FORCE AND PUSH THROUGH FORCE TEST

This test shall not be achieved for *DN* larger than 200 mm.

When tested in accordance with the method specified in Fig. A.1 of annex A, the forces (in N) shall be as indicated in Table 1.

**TABLE 1**  
**Maximum assembly and minimum push-through forces**

<i>DN</i>	Assembly force	Push-through force
50-100 inclusive	≤ 200 N	≥ 300 N
125-200 inclusive	≤ 300 N	≥ 400 N

### 4 JOINT STRENGTH

When carried out according to the supporting standard EN [155 WI 127], joint shall not part.

### 5 GAP BETWEEN COUPLER OR END PIPE AND PIPE

The gap *g* between couplers or reducers and pipes depends on the outside diameter of pipes. It shall not be more than as follows :

- up to *DN* 80 (inclusive):  $g \leq 1.5$  mm,
- from *DN* 100 (inclusive) to *DN* 125 (inclusive):  $g \leq 2.0$  mm,
- from *DN* 160 (inclusive) to *DN* 200 (inclusive):  $g \leq 2.5$  mm.

## ANNEX A – Couplers

### Test method for assembly force and push-through force measurement

#### A.1 General

This test obtains the force required to bring a pipe end to the pipe stop of the coupler (assembly force) and the force required to push a pipe corrugation past the pipe stop of the coupler (push-through force).

#### A.2 Procedure

##### A.2.1 Apparatus

A compression testing machine with a pair of steel plates is required. During testing these plates shall not distort in any way.

##### A.2.2 Samples

To avoid buckling the length of the sample is indicated in Table A.1, according to *DN*.

**TABLE A.1**  
Length of pipe sample to avoid buckling

<i>DN</i>	Sample length (mm)
50	80
60	80
65	100
80	100
100	150
125	150
160	200
200	200

The ends of the samples shall be cut square to the axis of the pipe.

##### A.2.3 Testing

Place coupler and pipe on the lower plate as shown in Figure A.1. Apply a force on the pipe by lowering the upper plate with a velocity of 30 mm/min.

The pipe shall not buckle during testing. In case buckling occurs, the test shall be repeated.

Both ends of coupler shall be tested, each end with a different pipe sample and a different coupler. The procedure shall take into account that, as far as possible, even when the marking on the coupler is symmetrical.

**FIGURE A.1**  
Testing assembly force and push-through force

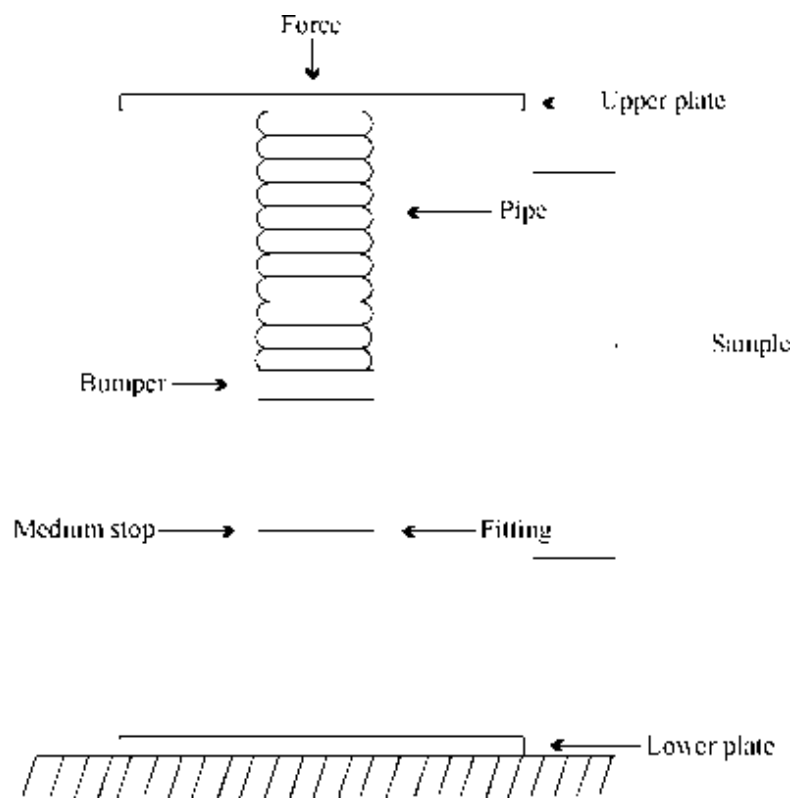

## PART 6: RECOMMENDED PRACTICE FOR INSTALLATION

### 1 SCOPE

Part 6 describes the recommended practice for installation of the piping system.

### 2 NORMATIVE REFERENCES

- ISO/TR 7073. Recommended techniques for the installation of unplasticized polyvinyl chloride (PVC-U) buried drains and sewers.

### 3 DEFINITIONS

For the purposes of this Part the definitions given in the other Parts of this European standard apply together with the following :

**3.1 Lateral drain:** Drainage pipe, direct receiver of water over full or partial length through perforations in pipe walls.

**3.2 Collector drain:** A pipe which collects water from lateral drains and conveys the combined flow to an outlet. If perforated, it may also act as direct receiver of water.

**3.3 Inspection shaft:** Auxiliary equipment at the junction of a lateral and collector drain or at the junction of several collector drains, used to change the gradient and/or direction and/or to facilitate inspection of a drainage network. Its design permits silt and sand to settle.

**3.4 Trenching machine:** A machine which digs a trench, generally of 0.10 m to 0.50 m width, and continuously lays the pipe at the bottom of that trench, which has to be backfilled after pipe laying.

**3.5 Trenchless machine:** A machine which continuously lays the drainage pipe, without any trench or excavation being opened, through a slit made with a vertical or V-form counter (e.g. V-plough).

**3.6 Backfill material:** Material which is installed on and/or under the drainage pipe during installation.

**3.7 Drain cleaning provision:** Auxiliary equipment which is composed of different plastic fittings, is installed on the collector drain and is used for cleaning the lateral drain with water under pressure.

**3.8 Mole drainage:** An operation of a limited life whereby a vertical counter fitted with a cylindrical bullet as optional expander is drawn through the soil to form a channel.

### 4 TRANSPORT, STORAGE AND HANDLING

#### 4.1 Transport

Vehicles should have a clean flat bed, free from nails and other projections which might cause damage to wrapped or unwrapped pipes.



Side supports should be flat and have no sharp or rough edges.

When transporting a mixed load of products (coils and/or straight lengths), it is important that the upper load does not damage the lower load. Large deflection and overhanging should be avoided.

#### **4.2 Storage**

For long term storage, it is important that the pressure on the lowest coil is kept as low as possible in order to prevent deformation of the pipe. Generally, a stock of four coils is appropriate in the field and eight coils at the manufacturer's premises or other prepared site. The coils should be stacked on a flat surface, free of materials which can damage the pipe. This applies to both wrapped and unwrapped drainage pipe.

Following delivery from the manufacturer until the effective installation, the storage duration between April to September inclusive should be as follows :

- for moderate climates - Scandinavia, the United Kingdom, Eire, Benelux and Germany - the outdoor maximum duration is three months.
- for severe climates - Iberian Peninsula, Italy, Greece and France - the outdoor maximum duration is 1.5 months.

In case of storage longer than these maximum durations, the coils should either be stored inside buildings or the stacks covered.

When pipes or coils are stored outside in climates having ambient temperatures greater than 23°C, stacks should be arranged to allow free passage of air around the pipes and coils.

Characteristics of envelopes (prewrapped loose materials and geotextiles) are much sensitive to weathering effects. In cases of long storage duration outside and for ambient temperatures above 23°C, filtered pipe should be stored inside buildings or covered.

#### **4.3 Handling (loading and unloading)**

Pipes should not be dragged along the ground or against hard objects. Whenever mechanical handling techniques are used, all equipment coming into contact with the pipes should present no protrusion.

When unloading pipes and coils, they should not be dropped on the ground. Pipes and coils should always be carefully lowered onto the ground or stacked where they are to be stored.

Whenever straight pipes have been transported one inside another, the inner pipes should always be removed first and stacked separately.

For products at low temperature as specified in 5.6, it is necessary to take extra precautions, particularly avoiding violent shocks to the pipes.

## **5. INSTALLATION PROCEDURE**

### **5.1 General**

It is assumed that laying of drainage pipes is mainly executed mechanically. The conformity of the delivery should be visually recorded by a representative of the customer.

### **5.2 Site examination**

Topographical (level) and soil surveys carried out before design should be adequate to allow an accurate assessment of drainage problems and a full and adequate drainage design to be compiled.

The location and condition of any existing drains and buried services should be determined where possible and incorporated into the new system.

Consultation with the land owner and all relevant authorities should take place before work commences. Scheme design should, where possible, avoid crossing buried pipes or cables and eliminate the need to work beneath overhead electricity cables.

### **5.3 Drainage plans**

Detailed plans under drainage should be prepared showing the layout, pipe size and type, use and depth of permeable backfill material and details of any mole drainage and subsoiling.

### **5.4 Use of machinery**

Machines should not be employed on an area until the preparatory work, such as initial pegging of the location of branch drains or any other topographical locating of future drainage pipes has been completed.

### **5.5 Trafficability and subsoil conditions**

Surface and subsurface soil conditions should be such as to avoid unnecessary smear or compaction at the surface or near the drain. High water tables, wet topsoil, puddles, can be detrimental to the drainage installation.

Surface tracking should be minimised at all times, especially when draining through growing crops.

Excessively high water table and excessively dry soil conditions should be avoided.

### **5.6 Weather conditions**

Pipe laying and the placement of permeable backfill over unplasticized polyvinyl chloride (PVC-U) pipes should not normally be carried out when the air or pipe temperature is below 0°C. When local climates dictate installation in lower temperature condition, pipe may be laid provided additional precaution are taken. Voluminous prewrapped unplasticized polyvinyl chloride (PVC-U) pipes may be used at temperature down to – 3°C.

In temperatures greater than 30°C care should be taken to avoid stretching of plastic drain pipes.

### **5.7 Setting up and checking of laser equipment**

The grading and depth control of land drains is of utmost importance. To obtain the correct grading and depth requirements, laser grade control equipment is now commonly used with land

drainage machines. The correct functioning and setting up of laser equipment is of great importance. Therefore, this equipment will require checking before it is used (see annex A).

## **5.8 Pipe laying**

### **5.8.1 General requirements**

Drain trenches should run in straight lines, unless topographical features dictate otherwise, at the required depth and gradient.

The pipe should be installed with a minimum depth of cover of 0.6 m from the top surface to avoid damage from surface traffic and preferably the pipe should be installed below the maximum depth of frost penetration.

All lateral drain lines should be plugged at the upper end to avoid ingress of soil or animals.

All collector drains should be installed from their downstream end to their upstream end. They should be prepared and installed before lateral drains.

All lateral drain lines should be installed from their downstream end.

Where mole channels should be drawn across the lateral drains, the pipe depth should be such that the invert of the mole channel is at least 100 mm above the top of the pipe. A minimum trench width of 100 mm is recommended and permeable backfill should normally be used.

Existing drains which are still active should be positively connected into the new system. All other existing drains should be connected to the new drains either by a positive connection or with permeable backfill.

Pipes with sealed joints or unperforated corrugated plastic pipes (in all other respects to the requirements of this standard) should be used where pipes are laid under any of the following conditions :

- a) through windbreaks consisting of trees and/or shrubs ;
- b) closer than 5 m from hedges or trees (other than in orchards) ;
- c) where leakage from the drain could cause erosion or scouring and displacement of the pipe.

A correct position is promoted by exerting some tensile stress on the pipes while laying them. A braking device on the reel for instance, is a useful auxiliary for this purpose. A pressure roll or similar device can also be used.

### **5.8.2 Pipe laid in trenches excavated by machine**

#### **5.8.2.1 Preparation of drain trenches**

The drain trench should be excavated in such a way that the ingress of water into the trench is not impeded by smearing of the trench walls.

The bottom of the trench should consist of naturally occurring soil. Normally, the base of the trench should be shaped by a tool to form a V-shaped groove, with the base of the groove radiused to a value not less than the outside radius of the pipe being laid.

### **5.8.2.2 Laying of drain pipes**

Drain pipes should be laid as trenching advances and secured in their position.

If pipe laying is suspended, the pipeline should be temporarily closed off.

Where pipe drains should be laid in very soft conditions, across backfilled trenches, or similar situations, a rigid drain bridge should be used to support the pipe.

Drain bridges can be of any suitable rigid material and should be laid in such a way so as to rest on at least 600 mm of firm soil on each side.

Soil beneath the drain bridge should be firmly compacted and any voids totally filled. Bridges should be installed during or immediately following drain installation. Pipes may require fixing to the bridge.

### **5.8.2.3 Securing of the position of pipes**

Drain lines should conform to the following requirements with regard to deviations from the prescribed slope line :

- a) the deviation of the inner bottom side of the pipe from the slope line stipulated should not be more than half its inner diameter ;
- b) at the same time the deviation may nowhere be such that in consequence of a negative slope more than half the pipe section remains filled with water after the drain discharge has ceased.

Before the drain trench is backfilled, correct positioning of the drain pipe and connections should be ensured.

The space between the drain pipe and the wall of the trench should be filled in such a way that the position of the pipe is not affected.

Wherever there is a risk of excess water causing pipe flotation, drains should be covered immediately after laying.

### **5.8.2.4 Backfilling excavated material**

Pipe trenches should be carefully backfilled as soon as practicable after installation with material placed in such a way that the pipes are not damaged or displaced. Trenches should be filled to a level sufficiently above the soil surface to allow for settlement. In case of sandy soils the trench should be filled with about 100 mm permeable non-humus soil over the pipe.

Frozen soil and soil which, due to excessive water content, tends to silt-up or to deliquesce, should not be used for filling the drain trenches.

### **5.8.3 Pipe laid by a trenchless machine**

Normally, the base of the laying device should be shaped by a tool to form a V-shaped groove, with the base of the groove radiused to a value not less than the outside radius of the pipe being laid.

When drainage pipes are laid by trenchless machines it is necessary to avoid jerky or tearing movements of the vehicles to overcome drags, or in case of soil slippage.

#### **5.8.4 Connections**

Immediately after being formed, the gradient and the connection should be secured against shifting by underpacking and lateral interlocking, using non-compacting durable materials.

When lateral drains should preferably be connected from above onto the collector drains, a rigid pipe with a minimum of 1 m should be used to form a connection and be suitably graded and supported.

Purpose-made junctions should be used when connecting lateral drains to collector drains. Under no circumstances should the lateral drain be permitted to extend into the collector drain.

#### **5.8.5 Inspection shafts**

Inspection shafts should be suitable for their function, durable and able to withstand their service load. No deviation should occur in the drain line. Shafts should be built on a frost-free foundation.

If the shaft is serving as a sludge or sand trap, the bottom of the shaft should be at least 0.30 m below the lowest pipe invert.

The inlets and outlets of collector drains should be constituted of rigid plastics pipes.

#### **5.8.6 Drain cleaning provisions**

The drain cleaning provisions should be installed in such a way that no deviations will occur in the drain line and that the drain can be cleaned in an upstream direction. The various parts should be firmly fastened and well fitted to secure the drain cleaning fittings. Backfill should be placed in well-compacted horizontal layers, about 0.30 m thick.

#### **5.8.7 Collector outlets**

A properly constructed outfall, of a suitable type, should be provided wherever a drain pipe discharges into an open channel. The invert, wherever possible, should be positioned at least 150 mm above the normal ditch water level.

A minimum 1 m length final drain should be of a rigid type. Any projection of the drain pipe beyond the bank should also be rigid and frost resistant. Vermin gratings should be fitted.

Headwall designs of outfalls should include slope protection and splash plates and should be securely anchored in position.

#### **5.8.8 Maintenance**

An auxiliary device such as a jetting piece may be connected to the piping system. In this case the end of the pipe should be closed by installing an end cap. Otherwise when possible the jetting piece should be directly connected to a chamber with a cover.

## **5.9 General considerations**

### **5.9.1 Safety**

#### **5.9.1.1 Human safety**

Due regard should be paid to all safety measures both on site and during transport.

The systems of work should be adopted and plant and equipment used so far as reasonably practicable, safely and without risks to the health of persons at work and others who may be at risk from the activities of persons at work.

Attention is drawn to the importance of ensuring that anything which may create a hazard and, in particular parts of machinery, are adequately guarded and that excavations are safe and adequately supported. Temporary excavations should be covered or guarded when the site is left, to reduce the risk of accidents to children and animals.

#### **5.9.1.2 Underground services**

All interested parties who have buried services in the land to be drained should be approached and enquiries made in writing as to the nature and location of such services. Farmers should be questioned concerning the presence of any buried services before work commences.

In all cases, the buried utility should be located and exposed by hand digging before drain laying. In the case of oil and gas pipelines, an inspector should be present during excavation and during pipe laying near or across the buried services. All contact with buried services should be reported immediately to the responsible authority.

### **5.9.2 Conservation**

Careful consideration should be given to the landscape and its wildlife habitats when undertaking underdrainage works. Suitable planning beforehand can ensure that the execution of drainage operations and their future maintenance will have a minimal effect on the environment.

Furthermore, a new scheme can often provide an opportunity to create new conservation features such as ponds.

## ANNEX A

### Recommended practice for use of laser equipment

**A.1** The tripod of laser transmitter needs to be placed firmly and free from influence by vibrations or similar effects. On soft ground - like peat - it is desirable that the transmitter is positioned outside the field to be drained if practical.

**A.2** If overhead power lines are in the area, and if the instrument is sensitive to them, it can not be placed under the power lines in order to prevent their influence on the laser.

**A.3** If the influence of radar is discovered, and if the instrument is sensitive to it, the drainage work can only proceed if the radar is not in use. The radar can also be transferred on request.

**A.4** A maximum distance of 300 m to the laser transmitter should be maintained during good weather conditions. During strong winds the maximum distance should be reduced to 200 m. During very high winds and under fog conditions drainage work should not be carried out. The speed of the drainage machine should be adjusted in accordance with conditions.

**A.5** To minimize the influence of wind during the setting up of the laser equipment, the following procedures are recommended :

- a) Place one of the tripod legs opposite the direction of the wind.
- b) Check if the snap-on couplings and bolts are tight and, if necessary, adjust them.
- c) Wind the cables to transmitter and receiver round one leg of the tripod or around the receiver mast.
- d) Tie down the tripod by placing a hook around the foot of each tripod leg, and place sandbags on them, or fix rubber bands between the middle of each leg and a weight or pin placed in the ground in the middle of the tripod.
- e) Protect the laser position by installing a temporary windbreak, or possibly use a van as wind protection. In this case, take care of turbulence behind the windbreak.
- f) Install the laser transmitter as low as possible and adjust the receiver mast accordingly.
- g) Keep the transmitter low in relation to the tripod and if a higher position is required, extend the tripod legs to maximum.

**A.6** Check if the grade installed compares with the real grade of the laser beam and repeat this check during installation of drains.

**A.7** Check the laser properly periodically.





## FAO TECHNICAL PAPERS

### FAO IRRIGATION AND DRAINAGE PAPERS

1	Irrigation practice and water management, 1972 (Ar* E* F* S*)	34	Corrosion and encrustation in water wells, 1980 (E*)
1 Rev.1	Irrigation practice and water management, 1984 (E)	35	Mechanized sprinkler irrigation, 1982 (C E* F S*)
2	Irrigation canal lining, 1971 (New edition, 1977, available in E, F and S in the FAO Land and Water Development Series, No. 1)	36	Localized irrigation, 1980 (Ar C E* F S*)
3	Design criteria for basin irrigation systems, 1971 (E*)	37	Arid zone hydrology, 1981 (C E*)
4	Village irrigation programmes – a new approach in water economy, 1971 (E* F*)	38	Drainage design factors, 1980 (Ar C E F S)
5	Automated irrigation, 1971 (E* F* S*)	39	Lysimeters, 1982 (C E* F* S*)
6	Drainage of heavy soils, 1971 (E* F* S*)	40	Organization, operation and maintenance of irrigation schemes, 1982 (C E* F S*)
7	Salinity seminar, Baghdad, 1971 (E* F*)	41	Environmental management for vector control in rice fields, 1984 (E* F* S*)
8	Water and the environment, 1971 (E* F* S*)	42	Consultation on irrigation in Africa, 1987 (E F)
9	Drainage materials, 1972 (E* F* S*)	43	Water lifting devices, 1986 (E F)
10	Integrated farm water management, 1971 (E* F* S*)	44	Design and optimization of irrigation distribution networks, 1988 (E F)
11	Planning methodology seminar, Bucharest, 1972 (E* F*)	45	Guidelines for designing and evaluating surface irrigation systems, 1989 (E*)
12	Farm water management seminar, Manila, 1972 (E*)	46	CROPWAT – a computer program for irrigation planning and management, 1992 (E F* S*)
13	Water use seminar, Damascus, 1972 (E* F*)	47	Wastewater treatment and use in agriculture, 1992 (E*)
14	Trickle irrigation, 1973 (E* F* S*)	48	The use of saline waters for crop production, 1993 (E*)
15	Drainage machinery, 1973 (E* F*)	49	CLIMWAT for CROPWAT, 1993 (E)
16	Drainage of salty soils, 1973 (C* E* F* S*)	50	Le pompage éolien, 1994 (F)
17	Man's influence on the hydrological cycle, 1973 (E* F* S*)	51	Prospects for the drainage of clay soils, 1995 (E)
18	Groundwater seminar, Granada, 1973 (E* F* S*)	52	Reforming water resources policy, 1995 (E)
19	Mathematical models in hydrology, 1973 (E*)	53	Environmental impact assessment of irrigation and drainage projects, 1995 (E)
20/1	Water laws in Moslem countries – Vol. 1, 1973 (E* F*)	54	Crues et apports, 1996 (F)
20/2	Water laws in Moslem countries – Vol. 2, 1978 (E F)	55	Control of water pollution from agriculture, 1996 (E* S)
21	Groundwater models, 1973 (E*)	56	Crop evapotranspiration, 1998 (E)
22	Water for agriculture – index, 1973 (E/F/S*)	57	Soil salinity assessment, 1999 (E)
23	Simulation methods in water development, 1974 (E* F* S*)	58	Transfer of irrigation management services: guidelines, 1999 (E F R S)
24	Crop water requirements, (rev.) 1977 (C* E F S)	59	Performance analysis of on-demand pressurized irrigation systems, 2000 (E)
25	Effective rainfall, 1974 (C* E* F* S*)	60 Rev.1	Materials for subsurface land drainage systems, 2005 (E)
26/1	Small hydraulic structures – Vol. 1, 1975 (E* F* S*)	61	Agricultural drainage water management in arid and semi-arid areas, 2002 (E)
26/2	Small hydraulic structures – Vol. 2, 1975 (E* F* S*)		
27	Agro-meteorological field stations, 1976 (E* F* S*)		
28	Drainage testing, 1976 (E* F* S*)		
29	Water quality for agriculture, 1976 (E* F* S*)		
29 Rev.1	Water quality for agriculture, 1985 (C** E* F* S*)		
30	Self-help wells, 1977 (E*)		
31	Groundwater pollution, 1979 (C* E* S)		
32	Deterministic models in hydrology, 1979 (E*)		
33	Yield response to water, 1979 (C* E F S)		

Availability: December 2005

Ar	– Arabic	Multil	– Multilingual
C	– Chinese	*	Out of print
E	– English	**	In preparation
F	– French		
P	– Portuguese		
R	– Russian		
S	– Spanish		

*The FAO Technical Papers are available through the authorized FAO Sales Agents or directly from Sales and Marketing Group, FAO, Viale delle Terme di Caracalla, 00100 Rome, Italy.*

## Materials for subsurface land drainage systems

This publication presents practical guidelines to assess the need for envelopes and to select appropriate materials (i.e. pipes and envelopes) for the proper and lasting performance of subsurface drainage systems. In addition, it contains guidelines for adequate installation and maintenance of drainage materials as well as the required specifications and standards of such materials, which may be used in tender documents for implementation of subsurface drainage works. Practical guidelines for the implementation of laboratory and field investigations to evaluate the performance of drainage materials have also been included. This paper aims to provide this practical information to drainage engineers and contractors who are in charge of drainage projects.

ISBN 92-5-105427-4 ISSN 0254-5284



9 789251 054277

TC/M/A0258E/1/12.05/1300