

# Manual on small earth dams

A guide to siting, design and construction



**Photography:**

Cover, Chapters 4, 5 & 6: Tim Stephens

Chapters 1, 3 & 9: Jacob Burke

Chapters 2 & 10: FAO/Roberto Faidutti

Chapter 7 & 8: Egle DeAngelis

---

**Copies of FAO publications can be requested from:**

SALES AND MARKETING GROUP

Office of Knowledge Exchange, Research and Extension

Food and Agriculture Organization of the United Nations

Viale delle Terme di Caracalla,

00153 Rome, Italy.

**Email:** [publications-sales@fao.org](mailto:publications-sales@fao.org)

**Fax:** +39 06 57053360

**Web site:** [www.fao.org](http://www.fao.org)

# Manual on small earth dams

A guide to siting, design and construction

FAO  
IRRIGATION  
AND  
DRAINAGE  
PAPER

64

by

**Tim Stephens**

Investment Centre Division

This manual has been prepared to help practitioners design and construct small earth dams in rural areas. It reflects FAO's and the author's best judgement and knowledge on the subject. Every reasonable effort has been taken to ensure that the information contained in this manual is complete, accurate and correct. FAO declines responsibility for any error or omission and in no event shall FAO be liable for any loss of business or profit, or for any direct or indirect, incidental or consequential damages arising out of any use of this manual. If users require engineering or other professional services, the assistance of an appropriate professional should be sought.

The Food and Agriculture Organization of the United Nations encourages the dissemination of material contained in this publication, provided that reference is made to the source.

The designations employed and the presentation of material in this information product do not imply the expression of any opinion whatsoever on the part of the Food and Agriculture Organization of the United Nations (FAO) concerning the legal or development status of any country, territory, city or area or of its authorities, or concerning the delimitation of its frontiers or boundaries. The mention of specific companies or products of manufacturers, whether or not these have been patented, does not imply that these have been endorsed or recommended by FAO in preference to others of a similar nature that are not mentioned. The views expressed in this information product are those of the author(s) and do not necessarily reflect the views of FAO.

ISBN 978-92-5-106547-1

All rights reserved. Reproduction and dissemination of material in this information product for educational or other non-commercial purposes are authorized without any prior written permission from the copyright holders provided the source is fully acknowledged. Reproduction of material in this information product for resale or other commercial purposes is prohibited without written permission of the copyright holders. Applications for such permission should be addressed to the Chief, Publishing Policy and Support Branch, Office of Knowledge Exchange, Research and Extension, FAO, Viale delle Terme di Caracalla, 00153 Rome, Italy. Or by e-mail to: [copyright@fao.org](mailto:copyright@fao.org)

© FAO 2010

# Contents

<b>Acknowledgements</b>	<b>vi</b>
<b>Acronyms, abbreviations and symbols</b>	<b>vii</b>
<b>1 Introduction</b>	<b>1</b>
<b>2 Background</b>	<b>3</b>
2.1 Introduction	5
2.2 Safety aspects and scope of the manual	5
2.3 Irrigation dams	6
2.4 Community participation	8
2.5 Social and gender aspects	9
2.6 The USBR manual on small dams	10
<b>3 Earth embankments</b>	<b>11</b>
3.1 Introduction	13
3.2 The homogeneous embankment	13
3.3 The zoned embankment	15
3.4 Cutoff trench and core	16
<b>4 Earth works</b>	<b>19</b>
4.1 Investigations	21
4.2 Soils	24
4.3 Mechanical analysis	26
4.4 Laboratory tests	26
4.5 Borrow areas	27
<b>5 Site selection and preliminary investigations</b>	<b>29</b>
5.1 Introduction	31
5.2 Aerial photography	31
5.3 Field visits	32
5.4 Preliminary surveys	33
5.5 Catchment yield	33
5.6 Storage capacity	33
5.7 Preliminary volume of earthwork	34
5.8 Catchment area and spillway dimensions	34
5.9 Peak floods	36
5.10 Calculating the PMF using the rational method	36
5.11 Estimates of storage required	39
<b>6 Detailed design</b>	<b>41</b>
6.1 Introduction	43
6.2 Contour survey	43
6.3 Revised capacity	44
6.4 Revised volume of earthworks	44
6.5 Design drawings	47
6.6 Estimated cost of dam construction	48

6.7	Outlet works	48
6.8	The embankment	52
6.9	Freeboard	53
6.10	Core depth and thickness	53
6.11	Crest width	53
6.12	Settlement allowance	54
6.13	Stone pitching and training banks	54
6.14	Seepage	54
6.15	Filters and drains	54
6.16	Environmental issues	56
<b>7</b>	<b>Dam construction</b>	<b>59</b>
7.1	Setting out the dam site	61
7.2	Plant and equipment	63
7.3	Compaction equipment and techniques	63
7.4	Site clearing and preparation	65
7.5	Settlement	65
7.6	Spillway	66
7.7	Constructing the embankment	66
<b>8</b>	<b>Special cases</b>	<b>69</b>
8.1	Introduction	71
8.2	Earth embankment on rock foundation	71
8.3	Earth embankment using poor earthwork material	72
8.4	An existing embankment with seepage problems	72
8.5	Masonry centre spill dams	72
8.6	Bulldozer dams	73
8.7	Dams in low rainfall areas	74
8.8	Estimating capacity in a raised dam	75
<b>9</b>	<b>Finishing works</b>	<b>77</b>
9.1	Introduction	79
9.2	Inspection requirements	79
9.3	Training banks	80
9.4	Other works	80
9.5	Maintenance procedures	80
9.6	Trees and bushes	84
9.7	Erosion	84
9.8	Termites and animal burrows	85
<b>10</b>	<b>Repair work</b>	<b>87</b>
10.1	Introduction	89
10.2	Structural defects	89
10.3	Non structural defects	93
	<b>Bibliography</b>	<b>95</b>
	<b>Glossary</b>	<b>96</b>
	<b>Annex 1</b>	
	Procurement guidelines for tender preparation, evaluation and award of contract	101

<b>Annex 2</b>		
	Cost benefit analysis	109
<b>Annex 3</b>		
	Fish production in farm dams	112
<b>Annex 4</b>		
	Examples of standard drawings	115

## Acknowledgements

The preparation of this book was funded by the Investment Centre Division and the Land and Water Division of the Food and Agriculture Organization (FAO) with initial financial support from the World Bank-funded Country Water Resources Assistance Strategy in Zambia.

The author wishes to acknowledge the support provided by many colleagues who contributed valuable insights, advice, criticism and editorial comments as well as photographs. M. Henri Tardieu is gratefully remembered for his technical review, the Dew Point DFID Development Resource Centre for Environment, Water and Sanitation for facilitation of a review of the manual by Professors R. Carter and M. Hann, colleagues in the Investment Centre and Land and Water Division of FAO, and to Jose Luis Castilla Civit and Jim Morgan for the formatting, layout and graphic design work.

This manual is based in parts on a publication by the author on the same subject and published by Cranfield Press (Stephens, 1991).



## Acronyms, abbreviations and symbols

A	Area of the catchment (km <sup>2</sup> )
A'	Area of the reservoir at full supply level (ha or m <sup>2</sup> )
CAP	Crisis Action Plan
D	Maximum depth of spillway at the crest
DFID	UK Department for International Development
ESP	Exchangable sodium percentage
FSL	Full supply level
GPS	Global positioning system
L	Length of the dam at full supply level
H	Crest height of dam at full supply level (m)
H'	Maximum height of dam at full supply level (m)
H''	Freeboard height (m)
PMF	Probable maximum flood
Q	Dam capacity (m <sup>3</sup> )
T	Throwback (m)
UNFPA	United Nations Population Fund
USBR	United States Bureau of Reclamation
USDA	United States Department of Agriculture
Y	Catchment yield (m <sup>3</sup> )



# Introduction 1

# 1 Introduction

This manual is designed specifically for engineers, technicians and extension workers involved in agriculture, commercial farmers and contractors – all with some understanding of engineering and some experience of dams, irrigation and water supply – involved in the siting, design and construction of small earth dams in the drier parts of the African continent. Such dams are suitable for supplying water to irrigation schemes, for rural and other water supplies (when properly treated) and for conservation measures.

The manual is derived from the author's many years of experience in dam design and construction in a number of countries in west, central and southern Africa and has been drafted with a view to providing, for the first time in this field, a collation of practical and useful guidelines for siting, designing and constructing small dams. Although derived from training and experience in Africa, the manual will be applicable to many other parts of the world and hence its publication by FAO. Thus, the manual essentially provides a comprehensive and pragmatic means for the practical understanding of the principles and procedures used in small earth dam construction and for the users to safely and competently construct small dams without recourse to the costly, complex and sophisticated design and construction techniques associated with dams on larger catchments.

The manual includes an introduction to community participation, social and gender issues in siting, constructing and operating dams, environmental issues and fish production as well as sections on costing dams, tendering for construction and awarding contracts.



Background 2

## 2 Background

### 2.1 INTRODUCTION

In many tropical, subtropical and Mediterranean climates, dry season agriculture and the pre-rainy season establishment of food and cash crops cannot be undertaken without large quantities of water. To rely upon streamflow at a time when temperatures and evaporation are often at a peak can be unrealistic and risky. It may become essential for a dam to be constructed on a river or stream to allow for off-season storage of vital water supplies. Although primarily for irrigation, such structures can be used, either separately or combined, for fish farming<sup>1</sup>, stock and domestic water purposes, drainage sumps, groundwater recharge, flood amelioration and conservation storage.

### 2.2 SAFETY ASPECTS AND SCOPE OF THE MANUAL

In all dam construction, safety must be given priority and users of this manual should follow the guidelines below:

- Users should restrict themselves to the construction of earth dams no higher than 5 m from streambed to finished crest level.
- Dams on catchment areas exceeding 25 km<sup>2</sup> or with reservoir areas storing more than 50 000 m<sup>3</sup> may require the advice of a hydrologist to assist in the design of spillways and other outlets and for the estimation of freeboard.
- No spillway should be less than 10 m wide and 1 m deep for catchments up to 5 km<sup>2</sup> and should be at least 15 m wide and 1.5 m deep for catchments exceeding this area.
- Any dam that involves out of the ordinary topography (i.e. steep slopes upstream, risks of landslips), hydrology (i.e. flash floods, droughts, snowmelt) or soils (i.e. poor quality soils, sodic soils, permeable layers in the soil, bare earth surfaces in the catchment) should only be designed and constructed under the supervision of a qualified engineer.

Before any dam is constructed, an assessment of the hazard potential should be made. This section and Table 1 provides guidelines:

Table 1: Hazard potential

Loss of life	Economic loss	Hazard potential
Almost impossible	Negligible	None
Extremely unlikely	Minimal	Very low
Improbable	Marginal	Low
Possible	Appreciable	Moderate
Probable	Excessive	High

A dam that is assessed with a high hazard potential should not be built without guidance, for both the design and construction, from a qualified engineer. Dams assessed as having moderate<sup>2</sup> or low hazard potential may need design modifica-

<sup>1</sup> Refer to Annex 3 for more information.

<sup>2</sup> Sometimes an extra category 'significant' is added to this sort of table between high and moderate. Equally the word *hazard* can be changed to *risk*.

tions, including increasing the return period for the design flood, to mitigate the perceived risks, improve stability and reduce susceptibility to flood flows or overtopping.

Increasing freeboard or designing the spillway for the passage of larger flood flows (including having ‘emergency spillways’) can reduce risks to dams from extreme rainfall events. Other modifications that can be made to the embankment are designing for flatter, more stable slopes (especially on poorer foundations or when using poorer earth materials), the introduction of seepage relief measures such as drains and filters and additional mechanisms to permit the release of water from the dam to lower water levels at times of hazard. This is further discussed below.

For all dams, except those assessed with no hazard potential, a **Crisis Action Plan (CAP)** should always be prepared. At a minimum this will comprise:

- Contact names and telephone numbers (owner of the dam, authorities downstream, police and emergency services and others) to call if the dam is damaged, develops problems or is considered unstable.
- Information on possible areas likely to be affected downstream (estimated area of inundation) should the dam fail or significant amounts of water require immediate release from gates, drains or outlets. A map to illustrate various levels of inundation (with estimates of timings for any flood wave) should be prepared and be available.
- A list of names, addresses and telephone numbers (keep this up to date) of inhabitants living immediately downstream of the dam and within the estimated area of inundation.
- The CAP should be periodically updated to take into account changes in land use downstream and any changes to the catchment upstream.
- Plans for warning and emergency evacuation, including the provision of safe routes to follow in case of flooding/dam failure. Immediate evacuation should take priority over any other action should the stability of the dam be threatened.
- Information on resources to use and procedures to follow for emergency repairs. This should include a list of civil engineering contractors, equipment and materials’ suppliers and engineers available locally.

Finally, when a dam is no longer required, or is considered no longer viable, it should be made safe. This could include safely breaching the embankment and returning the river to (as far as possible) its natural state or converting the dam into a conservation structure with a programme of inspection and maintenance to ensure it does not become neglected and eventually a risk to downstream areas.

## 2.3 IRRIGATION DAMS

The financial benefits from the cultivation of land in many parts of the world are rarely large enough to allow for expensive, technologically advanced concrete structures to be built for impounding water, whether on- or off-stream, and the alternative is normally an earth dam or simple weir.

The actual usable storage capacity of such a reservoir must be greater than the net demand over a season for a crop and must take the following factors into account:

- The storage should be below the calculated yield of the catchment in a dry year or based on an acceptable average minimal yield over a period of years.
- Irrigation requirement, which will vary according to the time of year, crop and irrigation efficiency, evapotranspiration rates and other climatic factors. Consultation with local farmers, agriculturalists and climatologists will allow estimates to be made of the total amount of water required per hectare cultivated. For example, wheat grown in a sub-tropical dry season winter in southern Africa will require 5 000 to 6 000 m<sup>3</sup> of water per hectare per 100-120 day season.
- Evaporation losses can be high and will depend upon climate<sup>3</sup> and the surface area of the stored water. A narrow deep reservoir will have a much smaller evaporation loss than a broad shallow reservoir, and as evaporation can vary from 0.3 m to 2.5 m per annum from temperate to arid climates, this can be a very important design consideration.
- Seepage will always occur with an earth dam and will depend upon site soil conditions, the embankment itself and the depth of the water.
- Dead storage is the name given to that part of the reservoir that cannot be drained by an outlet or by pumping. The latter depends largely on the suction arrangements of the pumping set up – a ‘flooded’ suction through the dam wall will result in very little dead storage whereas pumps located on the side of the reservoir or the embankment will never bring the water level to zero. Note should be taken that it is not always wise to drain a dam completely, most especially if ‘cracking clays’ have been used in the embankment, core or reservoir floor.

Thus, the anticipated irrigation demand from a dam must be linked to the yield of the catchment in any one year. For semi-arid and arid areas it may be wise to estimate a *dry year* catchment yield and use this for calculating the amount of water available for irrigation or other uses.

Embankment dams have many advantages over equivalent concrete structures and are most appropriate for farm or other rural situations. Dams up to 15 m high, when built on suitable sites and correctly designed and constructed using good earthworks materials, can be built using relatively unsophisticated design procedures and equipment. Farm tractors (equipped with dam scoops, scrapers and rollers) are usually adequate for the construction of such an earth dam which, once completed, should generally have cost less than a concrete wall, with its attendant complex design and construction procedures.

Smaller earth dams require minimal maintenance (unless in difficult locations or in extraordinary climatic situations), and are better able to withstand foundation and abutment movements than the more rigid concrete and masonry structures.

Further advantage can be gained by constructing the embankment from material excavated from the reservoir area. This provides a small increase in storage capacity and reduces costs. Construction on a layer-by-layer basis will allow for good compaction and stability and, spillway parameters permitting, for a flexible timetable of construction to be introduced. Compaction is an essential part of the construction process whatever the size of the embankment and should not be ignored – always pay more for the equipment needed as this cost will be recouped

3 Evaporation from dams in South Africa is estimated at 25–30 percent of the water stored per annum.

by the construction of a better, safer and more stable structure. Construction can be scheduled to fit in with climatic factors and plant and equipment constraints. It is not uncommon for the part of the core below ground, and perhaps the spillway, to be constructed in one dry season and the remaining embankment, training banks and outlet works to be completed in the next. In such staged construction it is essential that, at whatever height the wall is stopped in the first season, a spillway, whether temporary or permanent, is built to divert flood flows safely away from the partially completed structures.

Where farm machinery is being used, the construction schedule can be tailored to fit in with other farm uses to avoid tying up machinery at the expense of agricultural production. It is extremely important that all equipment used in excavation and construction is in perfect condition. A breakdown during a tightly scheduled programme can disrupt staggered procedures, delay completion up to another season and introduce expenses that could have been avoided by simple maintenance procedures. Similarly, when farm machinery is used, it is wise to allow for a complete overhaul of all mechanical and hydraulic systems following completion of the dam when working out costs. For example, the process of scooping and moving heavy clays consistently over long periods is particularly wearing on tractor engines and gearboxes and, if maintenance is ignored, major problems may occur later in carrying out conventional farm activities.

An earth dam will be unique to an individual site; although special emphasis will have been given to local conditions, certain guidelines and generalities can be applied to all dams. When followed, such guidelines will allow for the safe and economic construction of embankments. It must be stressed that, although most of the procedures are simple, and more a matter of common sense than advanced engineering knowledge, if the safety of any design or construction element is in question, a competent civil engineer must be consulted. A failed dam, however small, is not only a matter of a lost structure but can result in loss of life and considerable expense for those downstream. All procedures therefore, in selecting, designing and building dams must be followed to the highest standards possible.

Far too many earth dams are built with a disregard to engineering practice and to local regulations. Water rights and abstraction licences exist in many countries and these should be applied for before construction starts. These not only regulate the amounts of water that can be stored within or abstracted from a river system but also allow inspection and control of dam building to maintain standards of safety and construction. Similarly, most countries in Africa and elsewhere, have environmental regulations to follow, either for applying for a water right or for the approval of the physical construction of a dam.

Guidelines also need to be followed if the dams are to be constructed by contractors and Annex 1 provides general advice on procurement, tender preparation, evaluation and award of contract.

## **2.4 COMMUNITY PARTICIPATION**

For dams being sponsored by governments or other agencies for community operation and management, whether for agriculture or water supply, it is essential to consult local people. Try to obtain a representative view, not that of just landowners or important people in a community, but also those who will be most directly affected or benefit from any dam, to determine their needs and views. This is particularly important where the community is expected to contribute towards the



siting and construction (i.e. with the provision of land, their labour and possibly local materials) operation and maintenance of the dam. Responsible ownership of the dam and its catchment by the community, even if the dam is to be built by an outside agency, is vital for future maintenance and longevity of the structure.

Social and gender issues should be considered at this time and throughout the design and construction process. Men and women differ in their preference and needs for water and will be affected differently when the dam is finished and is storing water. It is important not to constrain the participation of women or the poor in decision making, in membership of groups associated with the dam (and any irrigation scheme) and in evaluating changes that will occur in workloads for men and women following the introduction of the dam and its related infrastructure. Section 2.5 provides further guidelines on this.

The establishment of dam committees at an early stage is strongly recommended. The main users of the dam should be well represented on this committee – in Africa women are often responsible for drawing water and should therefore be consulted on the site to be selected and be included in the committee. The same committee should later be converted to the operation and maintenance committee once the dam has been completed.

Training local people in all aspects of dam repair and maintenance may need to be included in the construction programme. Where local participation is expected in the construction process any contracts awarded to private contractors should clearly define all contributions to be made by the community and the contractors asked to modify their work programmes and practices accordingly. This may lengthen the construction period and increase costs but may prove worthwhile in the long term in enhancing ownership responsibilities and skills amongst the beneficiaries.

## **2.5 SOCIAL AND GENDER ASPECTS**

In most countries land and water rights are closely related, although water is often a public good, and therefore its use is associated with permits, concessions, and other tenure systems. Irrigated and rainfed land is the main source of livelihood for many rural populations. Women have much less access to this essential asset than men. The distribution of water and land is a major determinant of poverty.

Women and girls are typically responsible for collecting water for daily needs. This includes water for drinking, livestock, cooking, cleaning and overall health and hygiene within the household. According to the United Nations Population Fund (UNFPA), in 2002, women in many developing countries walked an average of 6 km a day to collect water. In southern Africa, migration of men from rural areas has led to an increase in women-headed households and an overburdening of women with tasks of maintaining households as well as farms. The availability of clean water close to home saves women's and girls' time, which can be spent on other productive and human development activities, such as crop production and education. Equally, it must be clear that the development of any irrigation scheme should not onerously increase the work load of both men and women.

Clear water rights lead to improved access to water, which is critical for maintaining good health and a sustainable livelihood. Studies from Africa show that both rural and urban women are engaged in small-scale enterprises and that improved access to water would help them to pursue these activities more effectively. Water quality

is very important in this context for the health standards of the whole household. Planning projects for multipurpose use of water requires a thorough investigation of the non-agricultural uses and, in particular, an assessment of women's needs.

Designing for a safe and hygienic water supply from dams is thus important. Protected shallow wells or boreholes, fitted with hand pumps, downstream of the embankment, to benefit from any underground seepage, can be useful combined with restricting access to the reservoir (fencing). Alternatively, a pipe through the embankment (installed at the time of construction) with a simple sand filter and water outlets for domestic and livestock uses could be considered. All designs and installations must be completed with the full participation of the end users to ensure that they are appropriate and sustainable.

To identify key issues in social and gender aspects, and to assist in evaluating anticipated impacts that any project may bring about, FAO has guidelines for the social analysis of investment in agriculture and rural development. The Gender in agriculture sourcebook, (World Bank, *et al.*, 2009) is another useful reference on this.

## **2.6 THE USBR MANUAL ON SMALL DAMS**

The reference text for dam construction is the United States Department of the Interior Bureau of Reclamation (USBR) Manual on the design of small dams (2006), and applicable to small dams constructed in the United States. 'Small' dams so defined are up to 90 m high. The technologies, procedures and methods of design and construction provided are tailored for such dams. Many of the design and construction procedures are not applicable to smaller 'farm' dams and cannot be downsized to become appropriate to the less sophisticated techniques and methodologies required. The USBR Manual is designed to be used by qualified, experienced engineers working on a range of dams and on large catchments in the United States. It is a useful reference but is not directly applicable to the small dams the present manual is targeting.



Earth embankments 3

## 3 Earth embankments

### 3.1 INTRODUCTION

Earth embankments have been used since the earliest times to impound and divert water. They are simple compacted structures that rely on their mass to resist sliding and overturning and are the most common type of dam found worldwide. Modern haulage methods and developments in soil mechanics since the end of the nineteenth century have greatly increased the safety and life of these structures.

The main advantages involved in the construction of small earth dams are:

- Local natural materials are used.
- Design procedures are straightforward.
- Comparatively small plant and equipment are required.
- Foundation requirements are less stringent than for other types of dam. The broad base of an earth dam spreads the load on the foundation.
- Earthfill dams resist settlement and movement better than more rigid structures and can be more suitable for areas where earth movements are common.

However, disadvantages also exist and these are:

- An earth embankment is easily damaged or destroyed by water flowing on, over or against it. Thus, a spillway and adequate upstream protection are essential for any earth dam.
- Designing and constructing adequate spillways is usually the most technically difficult part of any dam building work. Any site with a poor quality spillway should not be used.
- If not adequately compacted during construction, the dam will offer weak structural integrity, offering possible pathways for preferential seepage.
- Earth dams require continual maintenance to prevent erosion, tree growth, subsidence, animal and insect damage and seepage.

The earliest embankments were constructed on the principle of a solid wall of earth, whether impervious or not, across a stream or river. When built properly, such homogeneous embankments can still be cheap and reliable. They are, however, generally inferior to the modern method of zoned construction in which an embankment is built in three sections:

- upstream and relatively impermeable section;
- central core or hearting of highly impermeable material (which, with any below ground cutoff, will effectively seal the dam against seepage); and
- downstream section of poorer, coarser material that allows freer drainage of the structure and which, by its weight, anchors the complete embankment to its foundation and prevents slip and other movement.

### 3.2 THE HOMOGENEOUS EMBANKMENT

With this older type of dam, the build up of excess pore pressures within the embankment and seepage can be a problem, especially for a reservoir having high, or rapidly fluctuating water levels for long periods; or for a dam having impervious foundations. If seepage is excessive this can lead to instability and eventual failure of all or part of the downstream face. **Figure 1** illustrates the problem and offers some solutions.

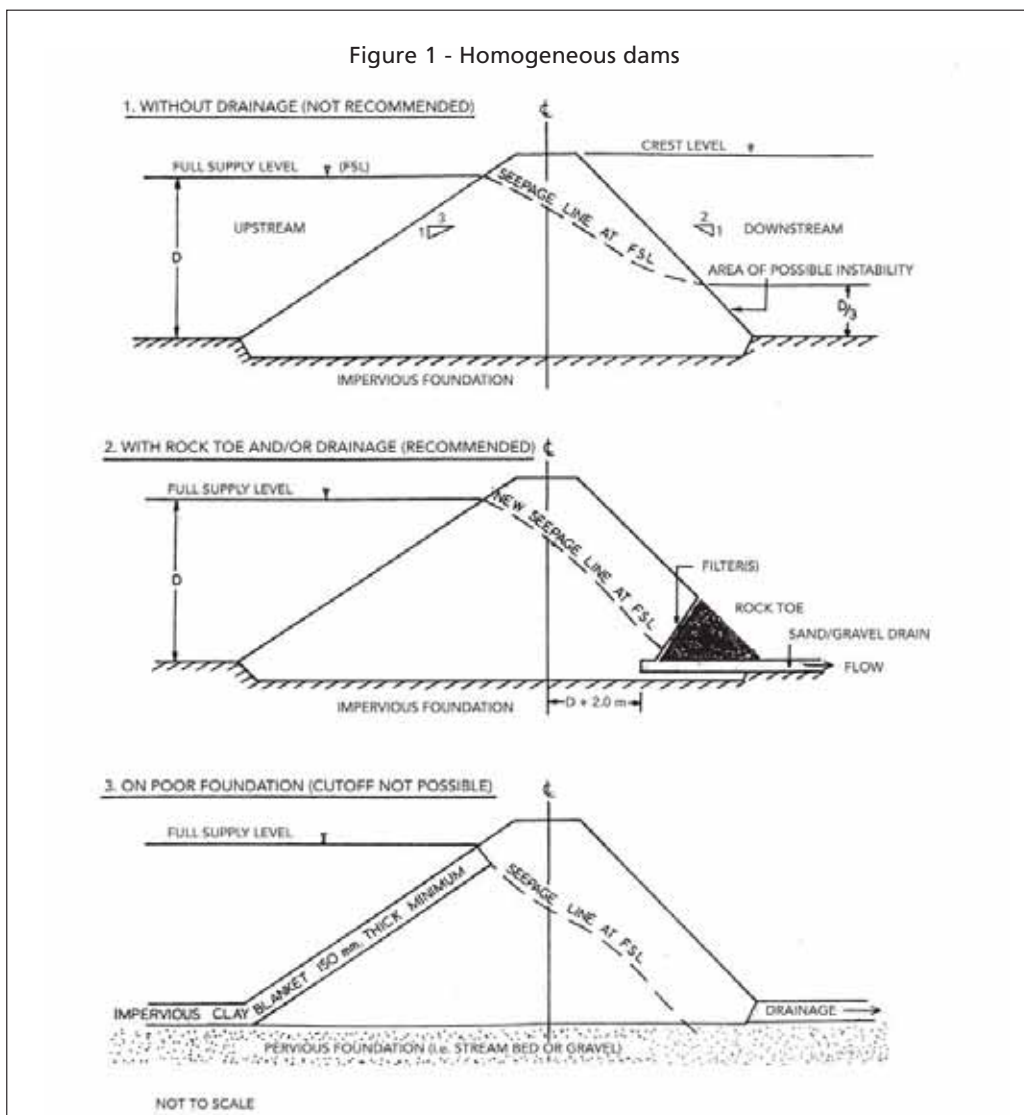

Either a rock toe or drainage layer ('blanket') of gravel or similar material will help relieve seepage problems in the downstream areas of an embankment on impervious foundations. The rock toe should be overlain by coarse sand and gravel to prevent embankment materials being drawn into it, a situation that could ultimately reduce the permeability of the toe and cause subsidence of the dam. In more pervious foundations (which often exist where dams are constructed on stream beds) exposure of a natural drainage layer can have the same effect of relieving seepage as an artificial gravel blanket or drainage layer.

Any seepage relief structure should only underlie the downstream section of the dam and should not extend into areas of the embankment that could permit percolation or direct seepage from upstream.

Generally, homogeneous dams should have relatively flat slopes (1:3 upstream and 1:2 downstream) as insurance against possible instability. A flatter upstream slope, required by all earth dams, allows the saturated section below water level to resist slumping. Also the weight of the water stored above it exerts a downforce which, when combined with the weight of the dam, equals or exceeds the horizontal thrust exerted by the depth of the water against the embankment. Note that the latter is dependent on the depth, not the volume of water, and that the horizontal thrust increases according to the square of the depth of the water. Therefore, building higher dams becomes more critical as, for example, doubling the water depth of a dam from 2 m to 4 m would increase the thrust fourfold.

Water levels should not be allowed to fall or rise too fast, especially if the embankment material is impermeable. This is because a rapid lowering of the reservoir could lead to slumping of the upstream face or, if the wall has been allowed to dry, a rapid rise in level could lead to erosion through cracks and fissures. Both may eventually result in erosion, loss of material and, in a worst case scenario, a breach.

### 3.3 THE ZONED EMBANKMENT

This is a better alternative, particularly for larger dams that readily allow the use of construction machinery. With this type of dam, possible seepage hazards are reduced to a minimum. Compared with homogeneous embankments, costs are likely to be higher, mainly because the earthworks material is divided into three categories: pervious for the downstream section, impervious for the core (or hearing) and semi-impervious for the upstream section, all of which has to be excavated from separate borrow areas (preferably within the reservoir area), thus increasing excavation and movement costs. Slopes, however, can be reduced to around 1:2 upstream and 1:1.75 downstream (or 1:2.25 upstream and 1:2 downstream for sites where only relatively poor impermeable material is available) and the material excavated in construction of the core can be used in the embankment, thus economizing on the use of earthworks.

**Figure 2** illustrates an ideal example of a zoned dam. Note should be made of the rock toe, which may be required for stability and to drain the downstream section (gravel drains may be necessary) and the stone pitching on the upstream face which, in this case, is necessary for protection of the wall from wave action. When laid correctly, stone pitching (**Figure 3** provides an example) can prove an inexpensive (if available locally) and efficient means of protection but should not be used on the ends of embankments and abutments and along the sides of spillways. These areas of a dam are extremely sensitive to erosion and may need to be concreted or shielded by gabions for maximum protection. The FAO publication on small dams and weirs in earth and gabion materials (FAO, 2001) provides guidelines on this.

Artificial impermeable materials, such as heavy duty plastic sheeting, have successfully been used in many parts of the world as an alternative to clay cores. In the tropics, however, such materials have been found to attract termites and rodents; have been burrowed into by animals and have not resisted settlement of the embankment after construction. Similarly, ant hill/termite mound material, often

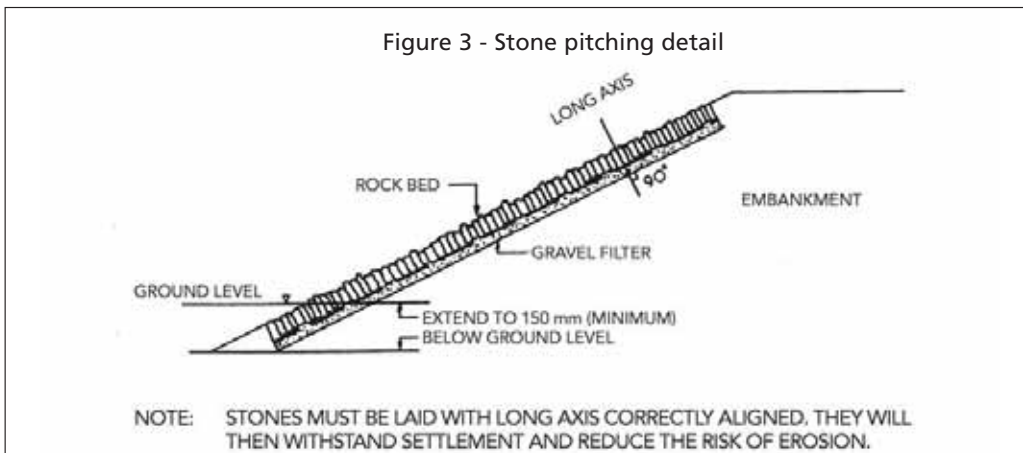
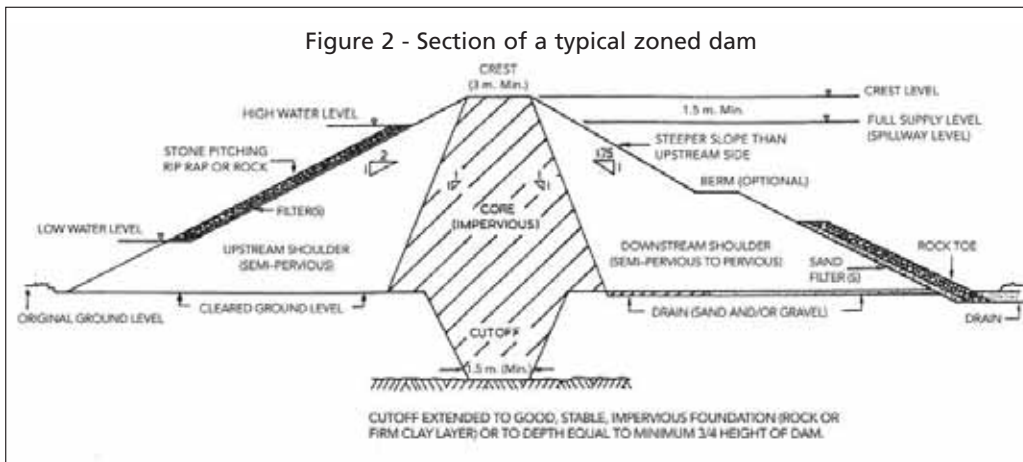

used because of its relatively high clay content, is losing favour because of its undesirable organic and mineral constituents; its variability within a small area and, once used, its subsequent attraction to termites (and their predators) despite its being treated with insecticide or mixed with diesel fuel. Where suitable core material is unavailable within economic limits, such material may have to be used, but must be analysed if possible; well 'killed' before excavation and treated when being installed.

Care is needed in the use of insecticides that could contaminate watercourses when absorbed by seepage or other water.

### 3.4 CUTOFF TRENCH AND CORE

Most dams, homogenous or zoned, can benefit from the construction of a cutoff in the foundation. A cutoff will reduce seepage and improve stability.

Whether stable clay, or other material is being used, the cutoff trench must be excavated to a depth that will minimize all possible seepage. Ideally, the cutoff trench should be dug down to solid rock that extends to great depths. If underlying rock is fissured or uneven it can be cleaned off and concreted to offer a good surface on which the clay can be laid. For larger indentations or cracks, slush grouting should be used, which is a thick slurry mix of cement and water poured and broomed

into the larger cracks and fissures before any concrete is laid to fill the remaining indentations and to offer an eventual mostly flat surface. For more even surfaces with smaller cracks, a cement wash (a weaker mix of cement and water to form a creamy texture) can be brushed across a surface to seal it and again establish a mostly flat surface layer.

The cutoff material should be placed in layers to a maximum 50-75 mm thick and to a minimum width of 1 m for small dams (i.e. hand laid cores) and layers 75-150 mm thick and 2-3 m wide for larger dams (i.e. material laid by scoop or scraper and compacted by machinery).

Every layer must be well compacted and if the whole dam length cannot be completed at any one time. Each section must be well keyed and bonded to the next since the cutoff trench and core are designed as one homogeneous unit to avoid seepage and structural problems. Compaction can be carried out by hand (tamping damp material by ramming poles 100-150 mm diameter) or by machinery (rollers or vibrators), or a combination of both. If farm tractors are being used, the tyres can be filled with water and, if a staggered track is followed across the width of the cutoff trench at the time of back filling, much compaction time can be saved. Light irrigation of the borrow area, some hours before excavation, can often assist in the scraping and scooping of the material, as long as it is not too wet.

Rain on the site can cause problems and an over-wet clay will prove difficult to compact. In this situation it is better to wait for the soil to dry before continuing with construction.

Continual or, at least frequent, monitoring of core material quality, moisture content and layering procedures is advisable, especially where inexperienced plant operators and labourers are being employed.

The importance of correct core construction cannot be over-emphasized. Failure to correctly carry out these comparatively inexpensive procedures could lead to expensive problems later that remedial measures will rarely completely resolve. If the core and cutoff trench have not been taken down to a firm foundation, or laid in layers thin and moist enough to allow compaction, it will be too late to introduce corrective measures after construction. In severe cases the dam can fail or not attain legislative approval – in either case an expensive mistake. The cutoff trench, and core of a zoned embankment, must be constructed of impervious material. Use of a soil that will not allow the passage of any water (i.e. impervious) is not necessarily desirable. This is explained in more detail in Section 4.





## Earth works 4

## 4 Earth works

### 4.1 INVESTIGATIONS

Ideally, the entire earth fill should be drawn from within the reservoir area and, if required, from any cut spillway areas. The importance of a correct analytical approach to determine the various soil types for a zoned embankment cannot be stressed too much. Although using a soil laboratory is expensive, the results can more than repay the cost involved and, more often than not, will ensure the exclusion of doubtful material in the construction process. This approach will include selecting the soils to be used, laboratory testing and mechanical analysis (if such facilities are available) to ensure the selected materials are suitable and interpretation of the results of these tests by an experienced engineer or technician to permit the appropriate materials to be used.

At this investigatory stage possible borrow areas should be identified – initially by eye, trying to ascertain soil type from vegetation, visible soil, position on slope and so on.

Preliminary exploration to determine suitable borrow areas for dam construction would:

- Explore areas for large quantities of soil material for inclusion in the embankment and any training walls. Ideally trials should indicate at least 150 percent of the estimated material needed for the dam is available (i.e. to cater for losses and wastage and poorer than estimated materials being found) and that the haul distances are not excessive.
- Explore areas for the provision of more specialized materials such as gravels (for drainage), aggregates (for concrete), filter materials, stone (for rip-rap or stone pitching) and high-quality clays for lining upstream surfaces and any canals.

The FAO Manual, on small dams and weirs in earth and gabion materials (FAO, 2001) has a detailed section on borrow materials, sampling and testing. The section below however provides basic details to follow in ascertaining the more favourable areas for investigation.

#### 4.1.1 Soil pits and trenches

Dig soil pits and auger holes to assess the top and subsoil layers and the foundation condition in the embankment area. Auger holes dug on a grid to depths of 3 m throughout a potential source area will allow a general assessment of soil types to be made. A series of trial pits and trenches can then be dug in more promising areas to allow a visual assessment of the soil profile to be made in line with local soil coding and classification techniques. Samples can be taken for subsequent texture and laboratory analysis.

#### 4.1.2 Texture tests

Texture tests are carried out to determine soil types. Excluding stones and gravels, the mineral part of the soil is made up of particles in three size ranges<sup>4</sup>:

- Clay: less than 0.002 mm diameter.
- Silt: 0.002-0.05 mm diameter.
- Sand: 0.05-2.00 mm diameter.

The relative proportions of sand, silt and clay are used to determine the textural class of a soil. The internationally accepted United States Department of Agriculture (USDA) Texture Diagram (refer to **Figure 4**) is a useful tool for initially demarcating soils for dam building. The USDA system is widely used throughout the world<sup>5</sup>.

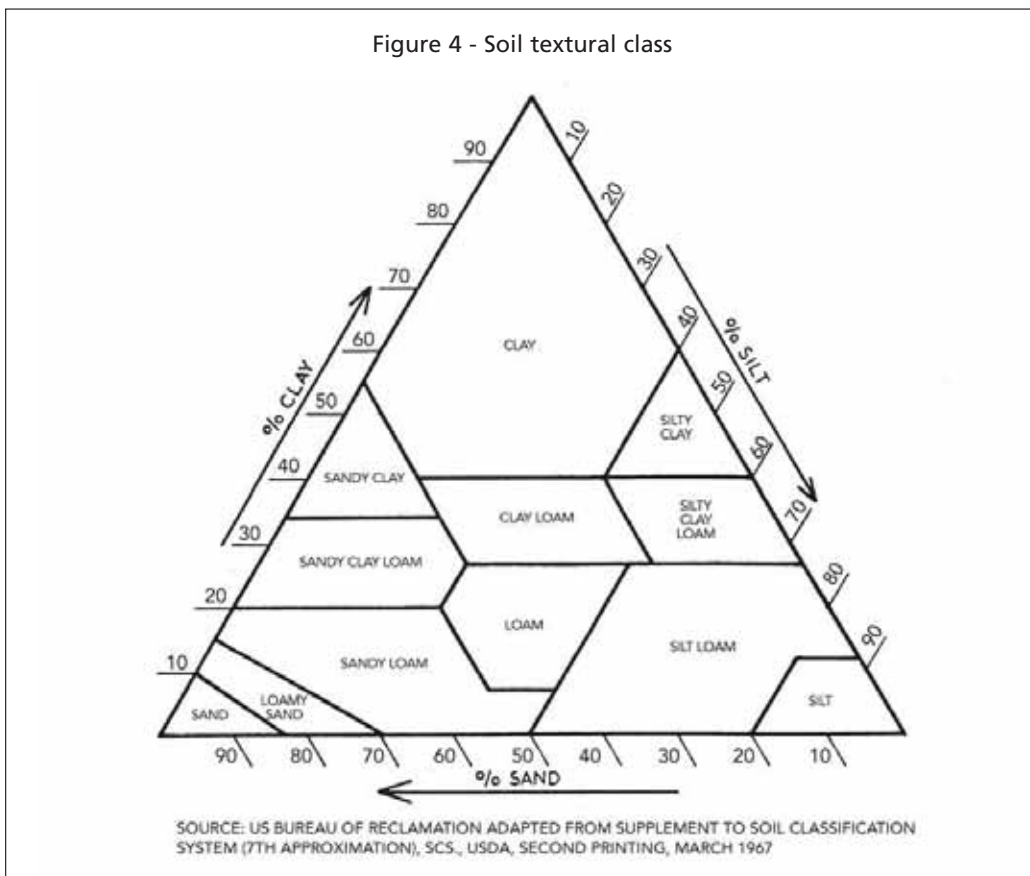

Basically, the textural classes involved are as follows:

Any soil with more than 55 percent clay can be considered as a 'clay'. A 'sandy clay' is a soil with between 33 percent and 55 percent clay and up to 65 percent sand. A 'sandy clay loam' has between 20 percent and 30 percent clay and up to 80 percent sand and loam.

<sup>4</sup> The figures vary according to who is defining: geotechnical engineers, sedimentologists, soil scientists and so on. The definition here is that for the USDA and adopted by FAO.

<sup>5</sup> The United Kingdom system varies slightly from this, mainly with minor differences in the classification of clays and clay-based soils.

Sands can be further defined according to the size of the grains (i.e. fine, medium and coarse) in the sand fraction.

Sands and clays, and combinations of them, are most suitable for earth dam construction. Generally, however, silty soils are unsuitable because of their inherent instability when wet and should not be included in any of the earthworks.

To precisely define textural classes requires laboratory techniques but, with experience and specific local knowledge, hand testing to determine texture can prove important for the initial stages of identifying appropriate earth fill materials. Clay soil areas can be demarcated in the field with the better soils (i.e. higher percentage clays) being reserved for the core and upstream shoulder of the embankment. Silts are often similar in both appearance and feel to wet clays when dry but can usually be differentiated when wet as the clay will exhibit sticky, plastic-like characteristics while silt has a silky, smooth feeling with a tendency to disperse.

Hand-testing techniques involve the taking of a small sample of a soil – usually in the hand not required for making notes – dampening it (avoid soaking it) and rolling it into a ball to examine its cohesive constituents.

A better quality clay can be manipulated into a thin strip without breaking up, rolled into a ball and dropped onto a flat surface from waist height without cracking unduly. Also, when cut it will exhibit a shiny, smooth surface.

The latest USBR Manual on small earth dams (USBR, 2006) has updated the section on soils according to types, defines a ‘Unified Classification’ and makes recommendations on slopes for dam construction (albeit for larger dams than this handbook will target) according to soil type. Compaction rates are also indicated to guide designers and constructors for smaller, simpler dams on smaller catchments and to reduce the needs for mechanical and laboratory testing of such soils.

#### **4.1.3 Infiltration tests**

At this stage, preliminary infiltration tests to obtain an indication of the soil’s permeability can be performed. The simplest way to carry out such tests involves filling auger holes or small pits with water, taking care not to over compact the soil within. A comparative evaluation of falling water levels over an area can then provide an indication of permeability and may indicate relative clay contents. Infiltration rings, which are used in the assessment of infiltration capacity for irrigation design purposes, can be used for the upper surface layers of soil.

#### **4.1.4 Core and cutoff material**

A soil is required that will limit the passage of water but not to such an extent that undesirable differential pressures could build up across and within the embankment. The impermeability of the soil used will vary between localities, but some standardization of water tightness can be achieved through varying the degree of compaction involved. A more pervious material will require greater compaction and vice versa. Generally, soils containing a significant percentage of clay are ideal for the core but clays with a tendency to crack should be avoided. If the latter are used they should be carefully compacted, placed in lower parts of the dam that are unlikely to dry out (such as in the cutoff trench) or covered by a gravel layer or topsoil with grass.

#### 4.1.5 Other embankment materials

Semi-pervious materials such as sandy clays and clay loams with a proportion of fines, such as clay or perhaps silt particles, are suitable for inclusion in the upstream shoulder. These will allow a limited passage of water and, in a properly constructed embankment, will resist slumping when wet. Where poorer soils are used, special attention to compaction techniques will have to be given to minimize the volume of air spaces in the soil and to maximize its stability when wet.

Pervious materials such as coarser grained sand and gravels – suitably washed and screened/sieved for size and grade – are used in the downstream shoulder and sections of the embankment requiring mass and drainage. Always seek specialist advice for use of these materials in drainage and filter works. These can often be better compacted dry or if only slightly damp. Once completed, a dry downstream face will prevent slippage and reduce risk of failure.

### 4.2 SOILS

Within a river valley a cross-section of soils may be available. The valley sides, where less leaching has occurred, can provide soils with a higher proportion of clay. The more heavily leached areas can provide amounts of sands, gravels and/or silts. The streambed proper should be a source for silts, sands and gravels, the latter being useful for drains and concrete work. Of great economic importance is the need to find such materials close to the dam site, preferably within the reservoir area, and in large enough quantities to justify their removal. Avoid complete removal of impervious materials, as exposure of more permeable layers beneath could lead to seepage problems in later years, especially when under pressure of several metres of water.

Investigation of proposed borrow areas is a necessary feature of any dam survey. This is carried out using auger holes, soil pits, boreholes and utilizing existing features such as wells and animal burrows to gain an extensive knowledge of the area.

#### 4.2.1 Clays

The best clay soil is always reserved for the core and cutoff and must be well compacted. Basically, the lower the clay percentage (to an arbitrary minimum as low as 3-5 percent), the more compaction and care in construction is required.

The upstream shoulder does not require highly impermeable clays as these could lead to undesirable uplift pressures developing beneath this section of embankment. More permeable clays usually have a good crumb or granular structure and include the typical red (but not lateritic) soils and the lighter self-ploughing basalt soils of central and southern Africa with their ability to move topsoil (when dry and crumbly) down through cracks in the profile. Sandy clay soils are most suited for inclusion in this upstream section as they compact well, have much reduced seepage characteristics but do not allow the build up of high soil-water pressures. Clays are not required in the downstream shoulder as it is essential that this section is free draining.

#### 4.2.2 Silts

Avoid including silts in any section of the embankment. The lack of cohesion, poor structure, fine material and difficulty in compaction are their main drawbacks. A

small proportion of silt is permissible, say in a silty-clay, but care must be taken in its use and application to ensure it is balanced with other soils and to keep percentage contents low.

As they can be confused with fine clays, it is important to differentiate the two when testing for texture. Laboratory analysis may, therefore, be required.

#### 4.2.3 Sands

A soil with a predominance of sand should not be used in dam construction. A sandy soil can be used in the downstream shoulder but should not be used elsewhere unless there is no alternative. If a sandy soil is used in the rest of the dam special attention must be paid to compaction, the best soil reserved for the core, and some consideration given to obtaining embankment water tightness by other means.

Sands do have an important role in larger dams as a filter material.

#### 4.2.4 Materials to avoid

Should there be any question about a soil's suitability, it is safest to avoid using it. Some materials should never be used in dam construction, in particular the following:

- Organic material (except when used to top dress the embankment and other parts of the dam site at the end of the construction period).
- Decomposing material.
- Material with a high proportion of mica, which forms slip surfaces in soils of low clay percentages.
- Calcitic soils such as clays derived from limestone which, although generally stable, are usually very permeable.
- Fine silts, which are unsuitable for any zone of the dam.
- Schists and shales which, although often gravelly in texture, tend to disintegrate when wet. Schists may also contain a high proportion of mica.
- Cracking clays that fracture when dry and may not seal up when wetted in time to prevent piping through them.
- Sodic soils, which are fine clays with a high proportion of sodium. They are difficult to identify in the field, so any fine clay should be analysed.

#### Sodic soils

Contact between a sodic soil and water leads to deflocculation occurring in the profile in which sodium has accumulated, entered the exchange complex and caused dispersion of the colloids. Consequently, reduction occurs in pore spaces affecting infiltration, permeability and aeration. The pH<sup>6</sup> and electrical conductivity (affected by soil salinity – sodium, magnesium and calcium being important) measured are in most cases high. Basically this leads to highly dispersive behaviour when wet (i.e. as most dam soils would be) and thus these soils do not act at all like clays (which bond together when wet) and are completely unsuitable to use in any embankment.

<sup>6</sup> pH is the standard measure of acidity related to the concentration of hydrogen ions. A pH of 7 is neutral, soils with a pH between 1 and 7 are acidic and those above 7 (to 14) are alkaline.

Any clays with a predominance of sodium (and, to a lesser extent, magnesium) among the exchangeable cations should be avoided as earthworks' materials. Laboratory results will generally show exchangeable sodium percentage (ESP) values higher than 15 and pH in the range 8.5 to 10 although lime-free soils can show pH values as low as 6. Structure will have significantly deteriorated and compaction tests will indicate easily mobilized soils that are structurally unstable when wet and under load. The proportion of clay to exchangeable sodium will also be important in so much that a sandy-clay soil with lower ESP values (i.e. 8 or above) will prove more unstable than a clayey soil with a higher ESP value.

Sodic soils are virtually cohesionless when wet and are responsible for many catastrophic earth dam collapses. Such failures usually occur soon after first filling of a dam reservoir and it is normally not advisable to attempt repair work as the embankment and foundation may still have sodic areas as yet unaffected. If sodicity is suspected the best rule is not to use any of the soil concerned and avoid such areas when extending dam, core or foundation work. However, for soils with low levels of sodicity, chemical treatment with gypsum and higher levels of compaction to increase the *in situ* impermeability (i.e. to keep the sodic soils dryer than normal) may help maintain stability where such soils have inadvertently been included in earth fill materials. Drainage will also be important to lower the phreatic surface within the embankment and to reduce pore pressures.

In central and southern Africa, sodic soils are most commonly found in 'mopane' (*Colophospermum mopane*) woodland and scrubland, which develop on granitic bedrock-derived soils (these have higher sodium-releasing mineral contents than their basaltic equivalents, which tend to be richer in calcium materials) in the lower rainfall and relatively hotter climates that allow sodium to accumulate in the upper soil horizons.

Marine clays found in Canada, Norway and Sweden, termed 'quick clays' and renowned for their viscosity and ability to flow great distances when wet are similar to mopane soils and have been created by the deposition of sodium within the soil horizons as pore water levels decline.

### 4.3 MECHANICAL ANALYSIS

Mechanical analysis of soil samples to assess constituents, mineral content, compaction characteristics and to check for other factors such as mica, silt, sodicity, etc., that may make apparently good soil unsuitable, should be carried out. Correlation of these results, which accurately assess silt, clay, sand and other particles in a soil, with previous work will allow estimates to be made of earth fill available, overburden to be removed and unsuitable areas to be avoided.

The importance of a correct analytical approach to determine the various soil types for a zoned embankment cannot be over stressed. Although using a soil laboratory is expensive, the results can more than repay the cost involved and, more often than not, will ensure the exclusion of doubtful material in the construction process.

### 4.4 LABORATORY TESTS

Laboratory tests on selected samples should be undertaken to confirm the field evaluations and to determine the physical properties of the soils. The following tests (refer to the methods and procedures detailed in the nine documents compris-

ing the British Standard<sup>7</sup> 1377 of 1990 (and 2007 amendments) for definitive information on compaction, compressibility, permeability and durability and shear strength) are recommended:

- Gradings: both mechanical sieving and hydrometer tests to determine the particle size distribution, identify the predominant soil type and the likely permeability of the material.
- Atterberg tests: measure the plastic limit and liquid limit of soil to enable the material to be classified and its suitability as a fill material assessed.
- Proctor test: to determine the maximum dry density and the optimum moisture content for use in compaction control during construction. Soils compacted to the maximum dry density are then at their maximum strength.
- Crumb test: to determine the disposition of the soil to disperse.

Examples of typical soils materials envelopes, based on a southern African laboratory (sieve) analysis, and according to particle size are given in **Figure 5**. In this figure, any soil materials meeting the specifications found between the heavy black lines would be suitable for inclusion in the parts of the dam embankment noted on the graphs. ‘Shell zone material’ refers to the upstream and downstream sections of a zoned embankment: they may need to be differentiated further where different materials are recommended for each section.

#### 4.5 BORROW AREAS

Borrow areas within the reservoir area should be given first preference, followed by those located on the valley sides close to the proposed embankment. Borrow pits in the reservoir have the advantage of increasing the upstream storage capacity and require no remedial work once the dam is completed.

Borrow pits should never be located close to the downstream toe area of the dam, the spillway or outfall or in any area prone to erosion.

Borrow pits located some distance from the dam site will increase construction costs, wear and tear on plant and machinery and the timing of the construction so always identify source materials as close to the dam site as possible.

---

<sup>7</sup> British Standards are available on line from the BSI Group website or from other websites and booksellers.



Figure 5 - Material grading envelopes

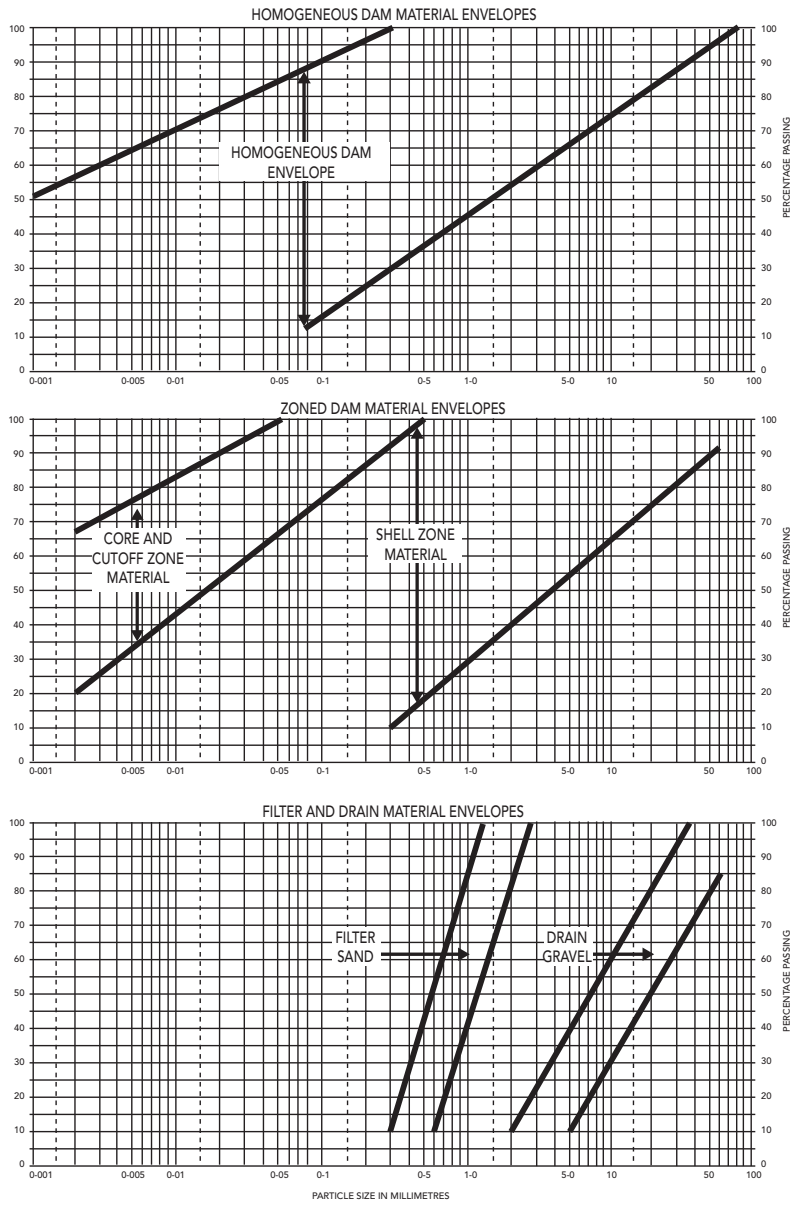

CLAY	FINE	FINE	FINE	FINE	FINE	FINE	FINE	FINE	FINE
	SILT FRACTION			SAND FRACTION			GRAVEL FRACTION		

MATERIAL GRADING ENVELOPES



## Site selection and preliminary investigations 5

# 5 Site selection and preliminary investigations

## 5.1 INTRODUCTION

Although the selection of a suitable site is essentially a field exercise, the use of aerial photographs<sup>8</sup> and large-scale maps can provide a useful assessment of the local topography and hydrological conditions before any field visit takes place. This is especially important on larger sites and catchments where much field time can be saved by allowing the poorest sites to be excluded and a list of the more promising sites to be drawn up.

Once the aerial photography interpretation has been completed and possible sites identified, a field visit is essential. Use of an accurate global positioning system (GPS) at this stage can prove useful. If the site proves difficult it should not be considered unless other overriding reasons demand that the dam be located in a specific area – in all such cases competent engineering advice is needed before any further work is done. It is important to identify where the water to be stored is to be used: irrigation, for example, involves the conveyance of large quantities of water and, if the dam-site is a long distance away from the cultivated area, much expenditure on pipelines and pumping may be required. For large irrigable areas, large diameter and costly high pressure pipes may be required and it may prove more economic to choose a poorer, more expensive dam site close to the land involved than a better site further away.

Other factors, such as access, availability of materials, land tenure issues, environmental concerns, community needs, the distance to the nearest power source and inundation of roads, bridges, and buildings should all be considered at this stage so that costly investigation work is not wasted.

## 5.2 AERIAL PHOTOGRAPHY

The procedure for using aerial photography is as follows:

- Area boundaries must be identified and delineated.
- Irrigable areas, pasture and developed land must be marked to allow the best location of potential sites. Catchment areas – outlined from following hill crests and other features – are normally taken from maps as catchments may extend beyond the limits of available photography. If the photograph is becoming crowded with detail, non-essential details can be erased to aid easier interpretation.
- Stream lines should be drawn in and areas that appear to have flatter gradients should be more heavily marked. Dam sites on steep slopes are rarely economic as embankments give limited storage so, where steep slopes (i.e. over 4-5 percent) are seen on the photograph or the map, such areas should be given low priority.

<sup>8</sup> 1:5 000 to 1:12 500 scale photos and 1:25 000 to 1:50 000 scale maps are most suitable for interpretation by eye and stereoscope. Satellite imagery to a suitable scale can also be considered.

A good dam site should have a catchment area that is not so big that an expensive spillway may be required but is also not so small that the yield from the reservoir is too low or erratic to be able to supply an economic area for any irrigation scheme.

Assessing the slope is difficult without a knowledge of the area and experience in aerial photography interpretation, so it may not prove feasible at this stage. Low gradients can be deduced from natural features such as meandering streams and ox-bow lakes, silt accumulations, swampy areas, right-angled tributary junctions and large-contour conservation and drainage spacings in nearby cultivated land. Once streamlines have been marked in, and channel sections evaluated, the more favourable sites can be located.

Priorities can then be drawn up based upon the indications above and the following geographical points:

- Where one or more streams/tributaries meet the main channel, the site may offer maximum storage.
- A desirable site is one that is close to where the water is required or that can allow delivery by gravity flow, low pressure pipeline, or canal.
- Where narrow channel sections exist for the dam itself, and with wider reservoir areas immediately upstream, this would result in a short embankment and large storage capacity.
- Where rock bars are found either in the river (for weir sites or centre-spillway dams) and/or on the valley sides for safe spillways. They are virtually essential on larger catchment areas where grass spillways are not advised.
- Where sudden changes in streambed gradient (from flatter to steeper downstream) may indicate good storage potential and allow a free draining site to be chosen for the embankment.

Streambed gradients, and estimates of dam height and length, can be made from photographs using a parallax bar or from digital maps through appropriate software. Even for an experienced operator, revision of such estimates must be made in the field. The extent of the reservoir upstream of the dam (the throwback) can be assessed by eye from photos or, in the case of larger dams, from local topographic maps, but again this will require field confirmation.

### 5.3 FIELD VISITS

Once the sites have been located, a field visit to the area can be organized to allow the most suitable site to be chosen. There is no alternative to physically visiting each potential site, and any others that become apparent at the time, or can be sited by discussing the above factors with local people, as interpretation from the aerial photograph or map is only a tool for preliminary assessment. A rough reconnaissance of every site within the involved area including, if necessary, estimates of levels and gradients (a sufficiently accurate GPS or hand level will prove invaluable at this stage), with checks on spillways, borrow areas and foundation conditions, will allow the relative merits of each site to be assessed. The most favourable sites can then be determined and preliminary surveys carried out.

#### 5.4 PRELIMINARY SURVEYS

The economic and design implications of each site can be determined from a brief preliminary survey, using a level/theodolite or accurate GPS equipment to take a line of spot heights across the profile (close to where the proposed embankment centre-line and spillway are estimated to be) and up the valley to provide indications of streambed gradient. The gradient is necessary to estimate the throwback of the dam and, for larger dams on flatter gradients, can often be estimated from contoured topographic maps of 1:50 000 scale.

For each site, the survey must be sufficiently accurate and detailed to enable comparative estimates to be made for various heights of dam. The most economic height is usually calculated on the basis of cost per unit volume of water. Comparison of the various alternative sites is then possible. More advice on surveying the site for later design work is given in Section 6.2.

#### 5.5 CATCHMENT YIELD

The catchment yield, 'Y', is based on the expected annual runoff from a catchment and is an important factor in assessing the feasibility of a dam and in determining the required height of the embankment. The latter is important to allow the dam designer to size the dam to suit expected inflow and estimate the area that can be irrigated. It is estimated as follows:

- Where the average percentage of runoff is not known, use, as a guide, a figure of 10 percent of the mean annual rainfall for the catchment area. If more information is known, take the rainfall on a return period of 1 in 10 years as a guideline.
- Calculate the annual runoff for the catchment, in mm, based on the percentage determined above. This is 'Rr'.
- Measure<sup>9</sup> the catchment area 'A' in km<sup>2</sup>, upstream of the proposed embankment. Ignore any upstream dams (as these may already be full at the time of a flood event – often at the end of a rainy season – and thus offer no retardation of any flood moving downstream) and calculate the area of the whole catchment.
- The annual runoff for the catchment (the catchment yield in an average year), Y, in m<sup>3</sup>, is given by:

$$Y = Rr \times A \times 1\,000$$

#### 5.6 STORAGE CAPACITY

At this stage, this is worked out as follows:

$$Q = \frac{LTH}{6}$$

Where:

Q is the storage capacity in m<sup>3</sup> and should not exceed Y above.

L is the length of the dam wall at full supply level (FSL) in m.

T is the throwback, in m and approximately in a straight line from the wall.

<sup>9</sup> Use a planimeter for topographic maps or the appropriate computer software for digital maps derived from satellite imagery.

$H'$  is the maximum height of the dam, in m, at FSL.

- 6 is a factor (conservative generally) that can be adjusted (to 5 or 4) with experience and local knowledge.

All the above measurements can be determined by the use of a level or theodolite (or accurate GPS equipment) at the site, either in the form of a cross-section survey at the centre line of the proposed dam or, more accurately and more time consuming (but more useful where comparison of similar sites is involved), by a contour survey followed by a survey or estimate of the throwback.

The capacity estimated in this way is accurate to within about 20 percent, but it must be revised by a more detailed survey when the site has been approved for possible construction.

The formula considers the water volume to be an inverted pyramid with a triangular surface area ( $LT/2$ ) and  $H'/3$  for the height/depth, and is a simplification of reality. With experience, one is able to judge fairly accurately how an individual valley will compare with such an idealized picture and, therefore, to adjust the resulting conclusions.

## 5.7 PRELIMINARY VOLUME OF EARTHWORKS

The volume of earthwork can be estimated as follows:

$$V = 0.216 HL (2C+HS)$$

Where:

V is the volume of earthworks in  $m^3$ .

H is the crest height (FSL+ freeboard) of the dam in m.

L is the length of the dam, at crest height H, in m (including spillway).

C is the crest width in m.

S is the combined slope value.

For example, if the slopes of the embankment are 1: 2 and 1:1.75,  $S = 3.75$ .

This formula is based on areal equations for the cross-section and longitudinal section with the inclusion of an empirically developed adjustment factor. Again, it presents an idealized solution and as for the capacity formula should only be used at the preliminary survey stage. The formula is, however, reasonably accurate and if a general average figure is known for costs of earthworks, a guide cost for the total embankment can be derived.

## 5.8 CATCHMENT AREA AND SPILLWAY DIMENSIONS

Accurate estimation of catchment area, either from an aerial photograph or a large-scale topographic map, is essential in the calculation of catchment yield and peak flood. For both, hydrological data (mainly rainfall and runoff), topographical factors and the shape of the catchment will be the main influences. The maximum design capacity of the reservoir is directly related to the catchment yield multiplied by a design factor that has usually been derived locally from the history of other

dams. In the case where a series of small dams is built in a catchment, the size of the catchment area for each dam should be taken as the total catchment area above the dam under consideration, not only the area between it and the one above it. The dam designer has to assume that the peak flood will occur when all the dams above are full and therefore will not have significant retardation or retention effects on the flood – this is most important for designing the spillway to safely pass the peak flood.

Dams should not be sited on catchments so small that they are unlikely to fill in an average year, except very rarely where other considerations, such as the provision of essential water supplies, are to be taken into account.

Estimations of peak flood are required for spillway design, the dimensions and physical characteristics of which are extremely important. If a suitable spillway of sufficient size is not available at a particular site, or would prove too expensive, it is advisable to move on to a better alternative site where spillway conditions can be met. On larger catchments (i.e. greater than 5-8 km<sup>2</sup>) and rivers of a flashy nature, rock spillways are virtually essential. Therefore, good solid rock of adequate width must be available for all but the smallest dams and, as a very rough guide at this stage and subject to re-assessment at the detailed design stage, a minimum width of 15 m at 1.5 m freeboard for a dam on a catchment of around 5 km<sup>2</sup> may prove suitable. However, advice from local engineers and experienced local people should be sought if hydrological data and/or design charts are not available.

It is probable that more earth dams in southern and western African suffer problems through poor spillway design than for any other reason. If there is insufficient rock, the site should not be used for a dam.

Grass spillways, whether cut or natural, are really only suited to small catchments (i.e. up to 5 km<sup>2</sup>) and low velocity flows (certainly below 1 m/s<sup>10</sup>) and even then may require continual maintenance throughout the life of the dam to prevent erosion from becoming too serious a problem. The ability of vegetation or soil to resist erosion is limited and maintenance of an even surface and uniform cover is very important. The stability of the channel as a whole will depend upon the stability of the most sparsely covered section and it is therefore wise to establish a good creeping grass cover throughout.

The grass cover condition will directly affect the channel's roughness coefficient, which will in turn depend upon flow. A low flow will meet high resistance while a high flow will flatten the grass and thus meet much lower resistance. Maximum allowable non-erosive velocities are highest in grass spillways that have been planted to shorter creeping varieties such as kikuyu, couch and star grasses. These can establish a uniform low cover offering minimum resistance to flow and maximum protection to the soil beneath.

However, where even normal flows are expected to constitute an erosion risk (i.e. if flow is expected to continue during the dry season and/or over a period of several months or more) a drop-inlet overflow spillway should be planned for and located at the opposite end of the embankment to the main spillway and at an elevation on the upstream side of the dam slightly lower (usually 50-100 mm) than full supply level.

---

<sup>10</sup> Table 4 in Section 6.

Spillway design dimensions are linked to the size and the character of the catchment. A catchment with rocky or steep surfaces (and thus high runoff) of the same area will have higher peak floods than a catchment within the same climatological zone with flatter, well-vegetated slopes. Similarly, a long narrow catchment will have a greater time of concentration of flood water after a rainstorm than a broad catchment with the same characteristics and therefore produce lower peak floods from the same area.

## 5.9 PEAK FLOODS

The peak flood is the probable maximum flood (PMF) to be expected from a catchment following a rainfall of estimated intensity and duration for a selected return period<sup>11</sup> taking into account the hydrological characteristics of the catchment. In many parts of the world information is not available or smaller streams are not gauged to allow estimation of such floods for spillway design purposes. On bigger dams and catchments, where it is more important that the spillway is correctly and properly dimensioned, it is economic to study the hydrology, climate, topography and so on to arrive at reasonably accurate estimates of PMFs. However, for smaller dams and catchments, unless this information is already available, the engineer can rarely justify the cost of such an exercise and must resort to other means to safely estimate the PMF.

Where the designer cannot use a hydrologist, or detailed hydrological information is unavailable, the **Rational Method** – based on catchment area and an assumed uniform rainfall intensity and runoff – is a useful tool for the estimation of peak floods on small catchments. For this manual it is assumed that the Rational Method will be used for most cases.

The Rational Method is most appropriate for catchments under 15 km<sup>2</sup> and requires the engineer to know the catchment area and the maximum daily rainfall. Other factors such as topography (especially the slope), the shape of the catchment and the vegetation cover may also require consideration. These are generally taken into account in the calculation of the ‘Time of concentration’.

Where other structures already exist in the catchment, ignore any flood reduction effects they may have as, in many countries, the maximum probable flood will occur at the end of the rainy season when all storage areas, natural or otherwise, are at full capacity and they will, therefore, have little effect in ameliorating runoff and retaining flood water.

## 5.10 CALCULATING THE PMF USING THE RATIONAL METHOD

The procedure to follow in calculating the probable maximum flood using the Rational Method is:

1. Locate the dam or new site on the appropriate topographic map (1:50 000 scale is normally suitable for all but the smallest catchments) and draw on the catchment boundary upstream of the embankment centre-line. Using a planimeter measure the catchment area, ‘A’, in km<sup>2</sup>.
2. Using a linear measuring wheel or similar device, measure the ‘actual length, L’, of the main river/stream, upstream of the site and to the main river source, in km.
3. Estimate the elevation difference, ‘h’, in m, between the dam site and the

<sup>11</sup> Usually 1 in 20, 25 or 50 years for small dams but it can be as high as 1 in 1 000 years for larger dams. In the case of Kariba dam, the spillway is designed for a 1 in 10 000 PMF.



main stream at its source. A contour map is essential for this and some extrapolation may be required where contour intervals are large.

4. Determine the time of concentration, 'Tc', in hours, using the formula:

$$T_c = (0.87 L^3/h)^{0.385}$$

5. From rainfall records or a rainfall distribution map, estimate the mean annual rainfall for the catchment. Using a graph similar to **Figure 6a**, estimate the one day storm rainfall, 'P', for the selected return period<sup>12</sup>. Use 1:20 to 1:25 year return periods for smaller catchments and 1:50 year return periods for larger dams, larger catchments or dams where safety issues are more important (i.e. near populated areas).
6. Derive the storm depth ratio, 'R', from the graph in **Figure 6b** and using the Tc determined above.
7. Calculate the extreme height channel slope as a percentage [100 h/(1 000 litres)] and estimate a runoff coefficient, "Cr", for the assumed return period using the graph in **Figure 6c**. If runoff is known to be excessive, such as on bare, eroded slopes, the runoff coefficient can be increased by up to 20 percent.
8. Determine the probable maximum flood (PMF), 'Qp', in m<sup>3</sup>/s, using:

$$Q_p = 0.278 A P R C_r / T_c$$

Where no other data are available and figures such as 6a to 6b cannot be drafted, a very approximate peak flood estimate can be made by taking the highest daily rainfall figure for the catchment and assuming that all dams in the same catchment are 100 percent full, the ground is saturated and that 100 percent runoff will occur. For example, if a rainfall of 223 mm fell on a catchment area of 19 km<sup>2</sup>, the estimated peak flood would be in the region of 49 m<sup>3</sup>/s over a 24 h period. Always stay on the conservative side when using approximations or estimates for peak floods; 2-4 m<sup>3</sup>/s per km<sup>2</sup> of catchment area per 24 h period is a guide but this figure should always be adapted bearing in mind local topographic and climatic conditions.

In Zimbabwe, the appropriate government departments, using accumulated meteorological and hydrological data, provide dam designers with charts to estimate spillway dimensions on small dams up to 14 m high on catchments up to 120 km<sup>2</sup> in area and formulae and tables for medium dams on larger catchment<sup>13</sup> areas. The Ministry of Agriculture, in conjunction with its field staff and engineers and the Water Court, control the building of smaller, farm-type dams in Zimbabwe and the charts are provided to farmers and agricultural extension workers to allow the calculation of dimensions of most spillways with a good factor of safety. The procedure for using the charts is straightforward and they can prove an invaluable tool to the dam designer – engineer in that area, although in most cases they are used with some modification based on local knowledge and experience.

The charts are based upon data and formulae tailored for central and southern African climates and topography. In Zimbabwe (and Zambia), the rainfall intensity and duration is that expected in a subtropical, rainy-dry season climate with total precipitation rates varying between 450 and 850 mm and falling during the five or six cooler months of the year.

<sup>12</sup> The return period is the flood recurrence interval for a selected discharge in a stream or river.

<sup>13</sup> For larger more complex dams on larger catchments, the Ministry of Water Development produces probable maximum flood tables based on a range of return periods from 1 in 25 to 1 in 10 000 years plus other information to safely and accurately size spillways.

For climates with less intensive rainfalls such as lower, coastal African locations and some North American and Australian environments, the peak floods would be lower and the spillways that much smaller.

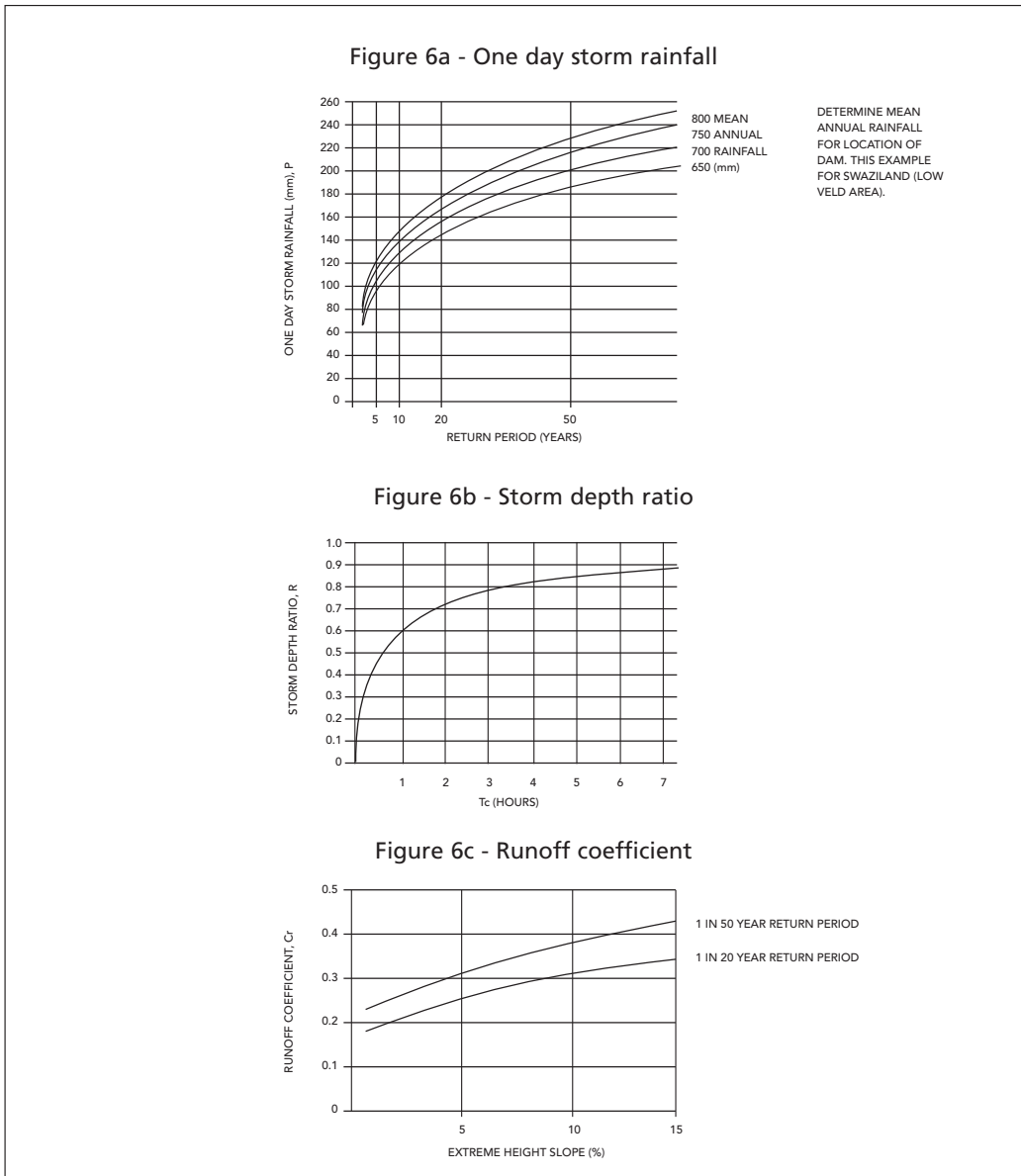

Where data are available, it would not be difficult to draw up similar charts or tables and once peak floods are determined, the hydraulic parameters for estimating spillway widths and depths are available.

In all cases, however, such charts and tables are by their nature generalized and should always be used with caution and, wherever possible, be adapted to suit local conditions.

Once the PMF has been estimated, the spillway width can be calculated using the formula:

$$Q_p = 1.7 b D^{1.5}$$

where  $b$  and  $D$  are in m and  $Q_p$  is in  $m^3/s$

'1.7' is a factor derived for concrete ogee type crests and can vary up to 2.25 according to site conditions and factors of safety. 1.7 is generally used for spillways for small dams on small catchments.

' $b$ ' is the minimum width ('breadth') of the spillway and is calculated by introducing the values for  $Q_p$  (estimated using the options above) and  $D^{1.5}$ . It is assumed that  $b$  is large when compared to  $D$  and that the spillway channel will thus be rectangular.

' $D$ ' is the depth of the spillway at the crest and will comprise all or part of the design freeboard.  $D$  is normally in the range 0.75 m to 1.5 m for small dams and comprises the total freeboard. However, where wave action or backing up of floods may affect the dam, an additional 'dry' freeboard of up to 0.75 m. should be added to the figure above for safety reasons.

Once all the other values are known, ' $b$ ' can then be calculated and the best option for varying depths, ' $D$ ', can be chosen.

The width ' $b$ ' is the minimum width for the spillway to accommodate the design flood. It assumes that there is no constriction downstream of the spillway. The width and depth may have to be adjusted to suit the local topography and spillway bed material later in the design process.

## 5.11 ESTIMATES OF STORAGE REQUIRED

At this time, it is wise to better assess the economic amount of water required from the dam.

This will, for irrigation dams, comprise irrigation requirement, other uses (live-stock/domestic water), losses to seepage and evaporation and dead storage.

- Irrigation requirement can be calculated by multiplying the gross annual irrigation requirement per hectare by the area proposed. This may have to be adjusted once the estimated storage for the dam chosen is calculated.
- Environmental flows to release normal flows into the river or to comply with any legal requirements downstream.
- Other uses such as livestock water can be calculated by estimating water use for this. FAO can provide advice as well as locally based government and other organizations. As a guideline the following (assuming the animals are on dry pastures and good quality water is available) can be used:
  - Cattle 40-80 litres/day for each animal (milking cows may need 100 litres/day).
  - Young stock 25-50 litres/day.
  - Pigs 25 litres/day.
  - Poultry 30 litres/day per 100 adult birds.
  - Bee hive 2 litres/day.
  - Sheep 2-6 litres/day.
  - Goats 3-8 litres/day.

- Camels            30-40 litres/day.
- Horses            40-50 litres/day.

Add 10 percent to any calculated total for water use by wild and feral animals and add a further 10 percent if the water is higher in salt content than recommended. Slightly saline waters can be tolerated by animals (but pigs and poultry are most sensitive) but they will have higher intakes to allow a greater water turnover to regulate body salt balances.

- Troughs are always recommended. Dams should be fenced off and no livestock allowed to drink directly from the reservoir or to damage the surroundings to the dam by overgrazing the catchment, tracking in the immediate surrounds of the reservoir and wallowing in the reservoir itself.
- Domestic water uses – opting for piped water supplies using filters or similar – can be calculated by determining the likely numbers of people who will use the dam for water and estimating total annual or dry season needs. A minimum of 20-50 litres/day per person in more rural areas can be used if piped water supplies are not to be provided but consideration for increases in use should be made in areas where populations are high and levels of urbanization may increase.
- Seepage losses are always difficult to estimate before the dam is built and to calculate after the dam has been constructed. As all dams will seep, it is best to estimate that a well constructed embankment will lose about 10 percent of its water to seepage in any one year.
- Evaporation losses can be calculated from local records noting that shallow large surface area reservoirs will have higher evaporation rates than narrow deep reservoirs. Wind is also an important factor in dry areas. Annual rates of evaporation from dams in Africa can exceed 30 percent but for calculating water uses (i.e. for irrigation), where actual figures are not known, dry season losses can be taken as 20 percent maximum.
- Dead storage is the amount of water retained in the dam that cannot be accessed. The dead storage will vary according to design, pumping suction heads and positions of any outlets in the embankment. It will also be more, proportionally, for a small dam than a larger dam and will offer an area in all dams for sediment to accumulate. For design purposes, a figure of 5 percent maximum of the total water stored can be used to estimate dead storage.

Once the above has been estimated the remaining amount available for irrigation can be calculated. It is at this stage the areas proposed under irrigation can be adjusted and any economic analysis made.



Detailed design 6

## 6 Detailed design

### 6.1 INTRODUCTION

Once all preliminary investigations have been made and a suitable site has been found, the next step is to carry out a detailed survey of the valley and reservoir area to allow more accurate estimates of quantities and to provide the necessary data for design work to be undertaken. The aim of such a survey is to present, on paper, a contour map of the reservoir up to and exceeding the maximum flood level, and to provide details for the location of the embankment, spillway and outlet works. From the contour map, the capacity of the reservoir can be assessed for varying dam heights. A depth-capacity curve can then be drawn up to provide a quick and easy method for the dam designer to choose the optimum full supply level. A simplified example of a depth-capacity curve is shown in **Figure 7**. Often the depth-surface area curve (usually with a reversed scale) is added to these graphs.

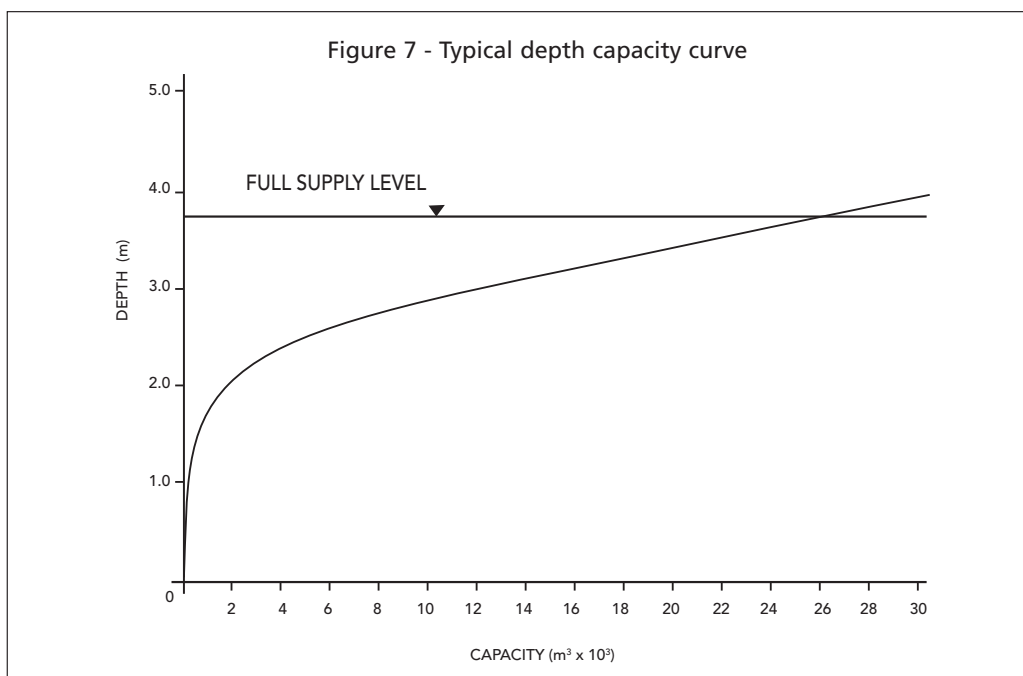

### 6.2 CONTOUR SURVEY

On very large sites it may be possible to draw up a contour map – at an interval suitable for the design (normally 0.5 m is satisfactory for small dams) – from aerial photography or satellite imagery using specialized stereo plotting and digitization techniques that, although expensive, may pay for themselves in the time saved in avoiding groundwork. However, if this is not possible, as is usual on smaller sites, one of three methods of ground survey<sup>14</sup> below will be necessary:

<sup>14</sup> High levels of accuracy are not required at this stage considering that elevations will later be affected by site stripping pre-construction.

### 1. Grid survey

This is a simple and straightforward but time-consuming method. Also it may not be possible if the area is heavily vegetated and/or physically inaccessible.

### 2. Cross-sections

Cross-section surveys are taken along various lines within the river valley(s) from benchmarks previously established. Levels are observed at set intervals and outstanding features (changes of slope in particular) are also noted.

### 3. Spot heights

This is especially suited to larger areas. A circuit of benchmarks is established and spot height observations with bearing, distance and elevation are made from each station. For smaller dams, and if a theodolite or electronic instrument is used, it may be possible to take all the readings from one station. Alternatively, reasonably accurate GPS surveys can be used to establish a network of elevation readings across the site.

## 6.3 REVISED CAPACITY

From the contour survey, an estimation of the surface area of the reservoir can be made for the full supply and other levels. The approximate capacity of the reservoir can be assessed from **Table 2** below. For example, to find the capacity of a reservoir with a maximum depth of 3.25 m and a surface water area of 32.7 ha, the following steps, extrapolating where needed, are made:

- (i) 30 ha at 3.25 = 325 000 m<sup>3</sup>
- (ii) 2 ha at 3.25 = 21 666 m<sup>3</sup>
- (iii) 0.7 ha at 3.25 = 7 583 m<sup>3</sup>

$$\text{Total capacity} = 354\,249\text{ m}^3$$

A quick reference check using the formula:

$$Q = \frac{H' A'}{3}$$

where H' is the maximum depth in m. (3.25 m) and A' is the surface area in m<sup>2</sup> (327 000 m<sup>2</sup>) results in a figure of 354 250 m<sup>3</sup> and closely correlates with that already determined from **Table 2**.

## 6.4 REVISED VOLUME OF EARTHWORKS

### Method 1

Although this method is not as accurate as Method 2 it is useful for the relatively rapid calculation of volumes of a number of proposed dams for comparison purposes. It is reasonably accurate in its estimates of quantities and subsequent costing of the proposed works. The embankment volumes are calculated, as in the example shown in **Figure 8a**, as follows:

Fill in the reduced level column on the left-hand side of the sectional paper, starting with the settled crest level on the top line. It is advisable, for ease of working, to consistently use a reference reduced level of 100 (largely to avoid having negative

values when referring to the crest height and to make any calculations above or below this reference level easy to work out) either for the highest or for the lowest point of the proposed embankment.

Table 2 Approximate reservoir capacities (in m<sup>3</sup>)

Reservoir area (ha)	Depth of water at deepest point						
	1 m	1.5 m	2 m	2.5 m	3 m	3.5 m	4 m
1	3 333	5 000	6 666	8 333	10 000	11 666	13 333
2	6 666	10 000	13 333	16 666	20 000	23 333	26 666
3	10 000	15 000	20 000	25 000	30 000	35 000	40 000
4	13 333	20 000	26 666	33 333	40 000	46 666	53 333
5	16 666	25 000	33 333	41 666	50 000	58 333	66 666
6	20 000	30 000	40 000	50 000	60 000	70 000	80 000
7	23 333	35 000	46 666	58 333	70 000	81 666	93 333
8	26 666	40 000	53 333	66 666	80 000	93 333	106 666
9	30 000	45 000	60 000	75 000	90 000	105 000	120 000
10	33 333	50 000	66 666	83 333	100 000	116 666	133 333
20	66 666	100 000	133 333	166 666	200 000	233 333	266 666
30	100 000	150 000	200 000	250 000	300 000	350 000	400 000
40	133 333	200 000	266 666	333 333	400 000	466 666	533 333
50	166 666	250 000	333 333	416 666	500 000	583 333	666 666
Reservoir area (ha)	Depth of water at deepest point						
	4.5 m	4.75 m	5 m	5.25 m	5.5 m	5.75 m	6 m
1	15 000	15 833	16 666	17 500	18 333	19 166	20 000
2	30 000	31 666	33 333	35 000	36 666	38 333	40 000
3	45 000	47 500	50 000	52 500	55 000	57 500	60 000
4	60 000	63 333	66 666	70 000	73 333	76 666	80 000
5	75 000	79 166	83 333	87 500	91 666	95 333	100 000
6	90 000	95 000	100 000	105 000	110 000	115 000	120 000
7	105 000	110 833	116 666	122 500	128 333	134 166	140 000
8	120 000	126 666	133 333	140 000	146 666	153 333	160 000
9	135 000	142 500	150 000	157 500	165 000	172 500	180 000
10	150 000	158 333	166 666	175 000	183 333	191 666	200 000
20	300 000	316 666	333 333	350 000	366 666	383 333	400 000
30	450 000	475 000	500 000	525 000	550 000	575 000	600 000
40	600 000	633 333	666 666	700 000	733 333	766 666	800 000
50	750 000	791 666	833 333	875 000	916 666	958 333	1000 000

Draw in the longitudinal section by accurately plotting ground levels against distance (on the upper scale marked crest length) and join these points with lines to show the cross-section profile of the valley. The spillway is not included.

Draw the cross-section of the proposed dam at its maximum height (i.e. above stream bed) after settlement, starting with the upstream toe on the left at zero (using the horizontal scale at the bottom and marked base width), working up to the crest, along and down to the downstream toe. This plotting must be carried out accurately as scaled dimensions are to be used in the calculations. Calculate, and check by measurement, values of  $w$  (i.e. the mean width of each 0.5 m or 1 m cross section) commencing with the crest section and enter it in the appropriate column and line.



Measure carefully the values of *l* (i.e. the length of the longitudinal section to correspond with each position of *w*) and again enter it into the appropriate column and line. Multiply each *w* by the corresponding *l*, and the height of the section *h*, and enter the result in the Volume column on the appropriate line. Total this column to give the volume of the earthworks in the dam.

If a training bank (to channel flows in the spillway to safe discharge) is to be constructed, this should also be calculated using the formula shown and added to the total volume above. Finally, add 10 percent to this total to include extra earthworks for settlement.

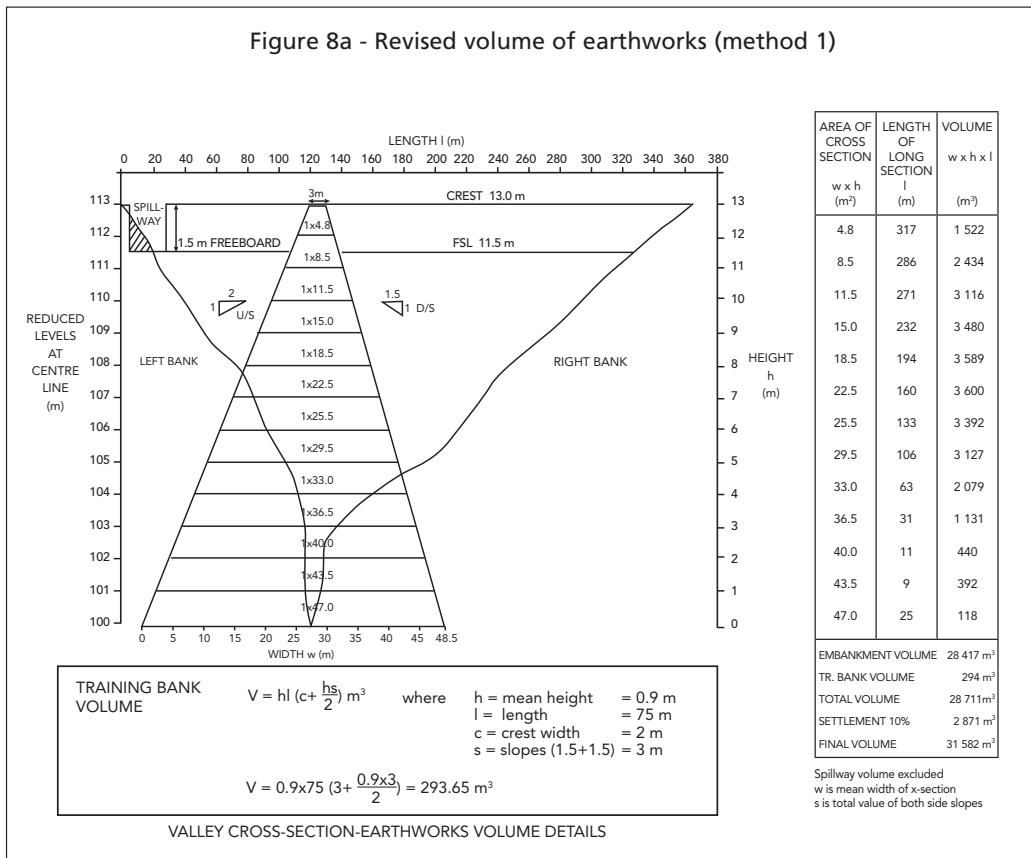

Comparison of this result with the result obtained from the formula

$$V = 0.216 HL (2C + HS)$$

is likely to lead to quite a significant difference. The formula result should be much greater, but this is acceptable as the formula is used for calculating the total cost of the dam and not the earthworks alone. At the reconnaissance stage, a general planning cost is required and this is calculated by using an estimated overall rate per m<sup>3</sup> of earthwork that will include all of the items detailed in **Table 3** in the next section.

### Method 2

Method 2 (see **Figure 8b**) is much the same as Method 1 except that the cross-sectional area is calculated more accurately. The cross-section is squared off as illustrated and each rectangle has its respective area calculated in a straightforward manner (i.e. length x breadth). The remaining triangular pieces which flank each rectangle have constant areas that are calculated as follows:

- upstream slope 1:2, height of section 1 m, area of upstream triangle =  $(2/2) \times 1 = 1 \text{ m}^2$
- downstream slope 1:1.75, height of section 1 m, area of downstream triangle =  $(1.75/2) \times 1 = 0.875 \text{ m}^2$

Therefore, each cross-sectional area can now be estimated relatively quickly and the method of assessing volumes proceeds as in Method 1.

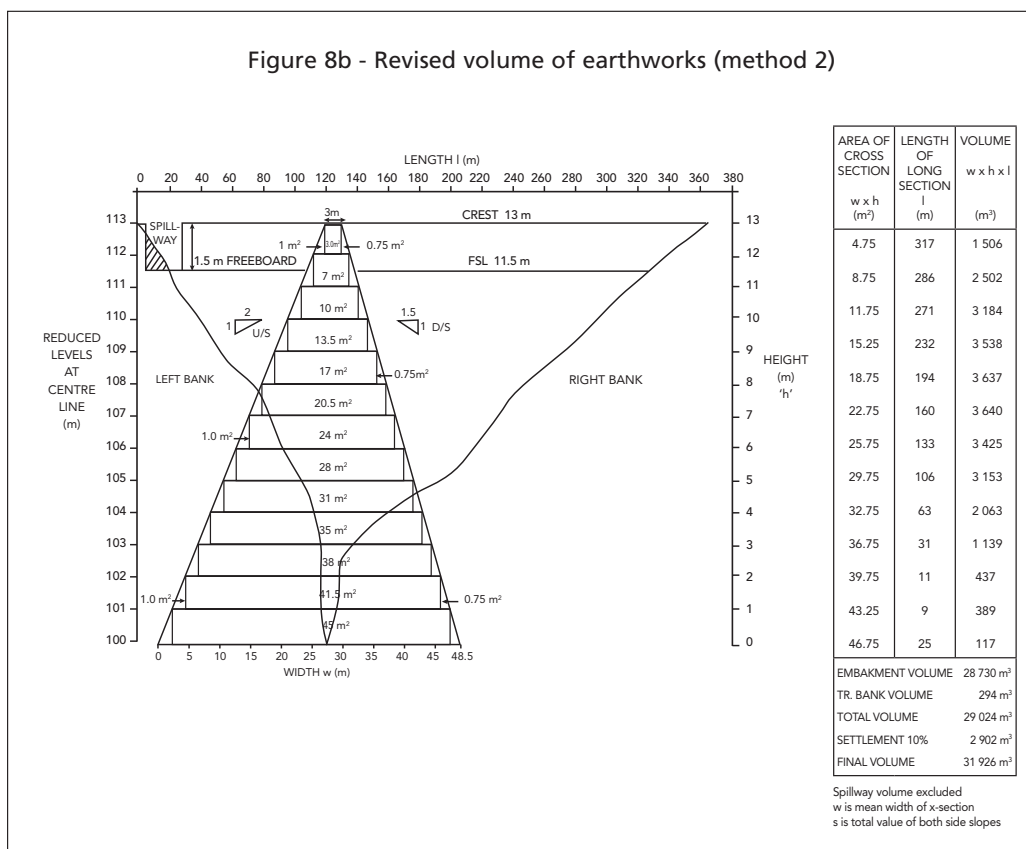

Finished versions of the method can then be presented on design drawings with allowances for over-excavation, training walls and settlement and without the calculations.

## 6.5 DESIGN DRAWINGS

It is important to provide comprehensive, useful design drawings for implementing the works and for eventual tendering and award of contract. Standardizing these drawings is equally important and being able to present one sheet with sufficient data on it to explain the design, list the main quantities and provide details of the

location is essential. Further drawings for more specialized aspects of the works can also be provided.

Standard drawings in A3 format are provided in Annex 4 with examples of the more specialized drawings required. Regardless of the design and its complexity or otherwise, all drawings should be of a high standard and be presented on quality paper as well as in electronic format.

## 6.6 ESTIMATED COST OF DAM CONSTRUCTION

The costing of the dam can now go ahead, with estimates based on either costs for dams already constructed in the same locality or rates provided by local contractors and or government departments. A list of quantities following the guidelines given in Table 3 can then be drawn up.

Should the dam (or dams) design and costing be prepared for tender or contracting to the private sector it is important that the details on costing for Table 3 and any engineer's estimates remain confidential and be used as a guide in evaluating any bids or other proposals from potential contractors to construct the dam(s). Annex 1 has more details on this.

Table 3 Quantities and costs of dam construction

Item	Description	Unit	Quantity	Rate	Amount
1	Site investigation	Sum			
2	Engineer fees	Sum			
3	Movement charge	Sum			
4	Clearing site	Hours			
5	Excavating cutoff/core	m <sup>3</sup>			
6	Backfilling	m <sup>3</sup>			
7	Embankment work	m <sup>3</sup>			
8	Training bank(s)	m <sup>3</sup>			
9	Spillway	m <sup>3</sup>			
10	Topsoil return	m <sup>3</sup>			
11	Trimming/tidying	Hours			
12	Other	.....			
				Subtotal	_____
				Contingencies @ x%	_____
				Total	_____

## 6.7 OUTLET WORKS

With any dam the major outlet work is the spillway, but other minor outlet structures may be required to release water for irrigation, trickle flows or other purposes.

### 6.7.1 The spillway

The spillway is the most important outlet and has to be designed to accommodate the anticipated peak flood. It has to be a permanent structure that will not erode and is located at a level that allows for the required water depth and freeboard ascertained at the site selection and investigations stage.

Critical items are the entrance width ‘b’ (already discussed above and dependent on the peak flood), the outfall (dependent usually on ‘b’ – refer below) and the material the spillway will be constructed with and sited upon.

For grass spillways, the erosion hazard is an important consideration. Therefore, this type of spillway should be horizontal at its entrance, ideally with a concrete or masonry sill to level the entrance and control velocities and erosion. It can have a slight crossfall (but no more than 5°) across the spillway and must have a safe outfall to return floodwaters to the stream. Allowable flow velocities will depend upon depth of flow (and in turn affect the freeboard) and the floor material of the spillway.

Guidelines to follow are presented in **Table 4**. The guidelines assume that an earth spillway is level and grassed with good, mat-forming creeping grass.

**Table 4** Guideline discharges and velocities for earth dam spillways

Type of surface	Sand to sandy loam	Sandy loam to sandy clay loam	Sandy clay loam	Light clay	Heavy clay gravel friable rock	Hard rock
Max velocity (m/s)	0.30	0.60	0.75	1.00	1.25	1.50
Flow depth (m) at spillway entrance	0.15	0.30	0.50	0.60	0.75	1.50
Discharge (m <sup>3</sup> /s per m width)	0.05	0.20	0.35	0.60	1.00	2.50

Calculations of minimum spillway width made for hydrological reasons should, at this stage, be modified to meet the guidelines above. Always accept the more conservative value – to thus increase spillway width – where dimensions vary.

### 6.7.2 Other outlet works

**Trickle flow outlets** are necessary where there would be perennial stream flow on grass spillways, as these will protect the earth spillway from the hazards of rills formed by a continuous low flow. The trickle flow can be passed out of the dam by either a drop-inlet overflow in the embankment or a trickle flow channel in the spillway. This may involve the use of reinforced concrete for which a set of standard specifications and methods of construction are advised.

### Drop inlet overflows

A drop inlet overflow consists of a pipe (or pipes) installed at the time of construction and set to an upstream level just below spillway (full supply) level. It is of a diameter large enough to carry all but the flood flows. Depending on the design discharge, the pipe can either protrude directly from the wall (for smaller flows) or have an inlet chamber (for larger flows) located adjacent to the wall but designed to prevent vortexing and possible erosion of the upstream face of the embankment.

The main spillway can be reserved for flood flows and problems of gullying will thus be avoided (erosion may still occur as a result of floods. This should only happen infrequently and can be treated accordingly).

The pipe, as illustrated (with inlet chamber) in **Figures 9a** and **9b**, must be carefully laid, true to line and level. Steel pipes should be flanged and concrete pipes should have staunching rings (anti-seepage collars) to prevent seepage of water along the

outside of the pipe. The pipe should be laid in a trench cut in original ground on the valley sides before the embankment is built. If stream flows are not known, the minimum diameters of pipe are as follows:

- 300 mm for very small catchments.
- 375 mm for catchments up to 5 km<sup>2</sup>.
- 450 to 550 mm for catchments between 5 and 8 km<sup>2</sup> (i.e. '44 gallon' drums in concrete).

For known expected maximum stream flows the diameters of the pipe and its physical gradient can be selected from **Tables 5a** or **5b**.

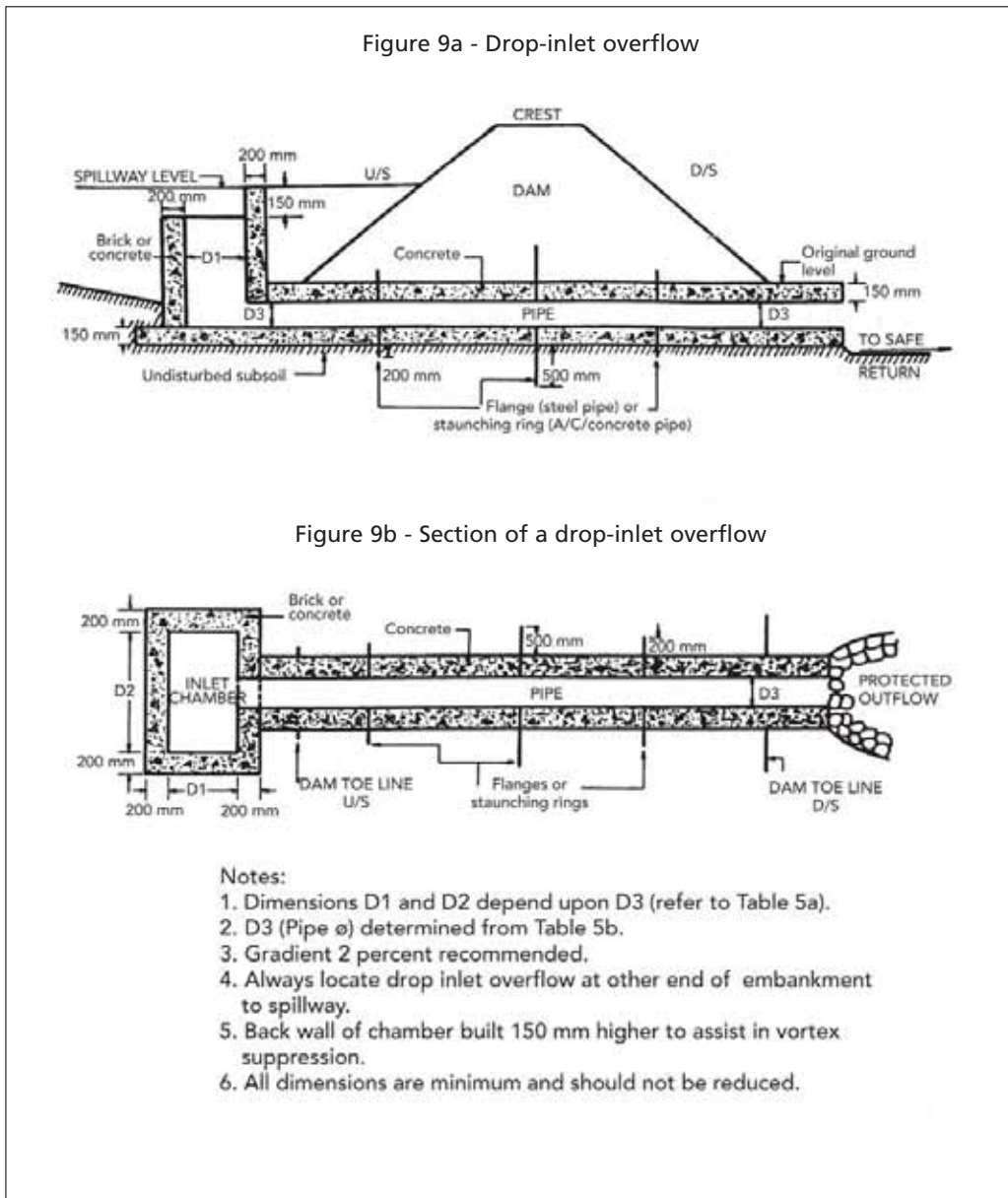

**Table 5a** is based on a maximum flow velocity of 2 m/s or a maximum friction head loss of 2 m per 100 m of pipe. See **Figures 9a** and **9b** for D1 and D2.

### Trickle flow spillways

Where normal flows are small or a drop-inlet overflow was not installed at the time of construction, a trickle flow spillway can be constructed within the existing grass spillway(s). A well founded stone-pitched or brick-lined channel designed to carry average stream flow can avoid subsequent erosion of the main spillway. A concrete or masonry sill placed across the entrance and exit of the grassed spillway will also reduce risk of erosion as well as allowing for control of the full supply level in conjunction with a drop-inlet pipe. Maintenance (de-silting and repair works) may be required after major floods or at the end of each rainy season.

**Table 5a – Guide to minimum dimensions of drop-inlet chambers and pipes**

Dimension D1 (mm)	Dimension D2 (mm)	Diameter D3 (mm)	Capacity (litres/s)
300	300	100	15
500	300	150	30
600	500	225	70
1 200	500	300	125
2 000	1 000	375	200
3 000	1 600	400	250

**Table 5b – Gradient chart for drop-inlet overflow pipes**

Q (l/s)	Internal diameter of pipe (mm)							
	75	100	125	150	225	300	375	400
	Approximate gradient required (1: ...)							
1.5	320	1 470						
3	80	370	1 210					
6		90	300	800				
9			135	350				
12			75	200	1 750			
15			50	130	1 130			
20				80	700			
25					350	1 600		
30					280	1 300		
40					180	830		
50						400	1 300	
60						325	1 070	2 300
75						210	690	1 800
100							300	750
150							170	450

Note: Pipes are assumed flowing full, under negligible water pressure and are constructed of concrete or similar.

### 6.7.3 Training banks and spillway outfall

Whether the spillway be grass, rock, drop-inlet, or trickle flow, an essential requirement will be a safe return to flow downstream of the embankment. For any spillway the avoidance of bends or constrictions to the channel must be adhered to.

Grass, and occasionally rock spillways, may require the construction of training banks (stone pitched if necessary) to guide the flood flows away from the steeper

slopes and the downstream toe of the dam. A maximum slope of about 5 percent for the return should be the goal and this should only be exceeded where rock is to be used for the return. The actual outfall should be designed to be non-erosive and, as a rule of thumb, the final width should be 1.5 to 2 times the entrance width 'b' thus reducing velocities of flow to manageable levels. Examples of training bank and outfall designs are provided in the sample layout drawings in Annex 4.

On rock spillways, downstream erosion that will not endanger the embankment or cause environmental problems and which will stop once the flow has eroded back to the rock, is permissible. For drop inlet overflows the construction of a channel of brick or stone from pipe outlet should be sufficient and this can then be led to a safe dissipation point downstream.

If farm machinery or other vehicles are expected to use the embankment and spillway as a road, the side slopes of the spillway should not exceed 25 percent and some protection (i.e. stone or concrete crossings) from erosion by traffic should be constructed at the time of building the dam.

#### 6.7.4 Other outlets

Where the expected flows are sufficiently small, pipes leading through the embankment high up on one bank at full supply level may be used and will prove cheaper than a box inlet type overflow. Care must be exercised in leading the flow back to the streambed and usually a stone pitched, brick or concrete lined channel is required. Outlet pipes are often required where a regulated flow of water is needed and these will be of steel or concrete with a control valve installed. The best option is to lay the piping beneath the embankment (even if high up on the bank) at the time of construction and it is important to ensure good rock or compacted soil foundation along its entire length. The trench should be cut to size, (i.e. as narrow as possible), with provision for seepage collars or flanges every 4-6 m and the pipe laid on a bed of concrete and then covered by more concrete.

If the dam is already constructed and an outlet pipe is required, excavation into the embankment is not recommended as this would create an area of weakness in what is meant to be a unified structure. The alternatives are either to pump from the upstream side over the embankment or to construct a siphon.

The pump(s) could be located on a raft with a flexible connection to a fixed pipe on the dam, or be positioned on a ramp that will allow them to follow water levels as they rise and fall to avoid too high suction lifts occurring (i.e. more than 3-5 m).

Siphons require careful construction to ensure all joints and valves are airtight and, as insurance, some means of priming at the highest point may be incorporated in the pipeline. With a siphon it is essential that the outlet be located at a level below that of the inlet when the water level in the reservoir is at its lowest. Siphoning water over an elevation of more than 5 m is not advisable and it may be necessary to minimize the elevation difference by burying the pipe into the top portion of the embankment.

### 6.8 THE EMBANKMENT

The embankment is the principal part of the dam and certain guidelines in design and construction must be followed: the side slopes must not be steeper than 1:2 on the upstream and 1:1.75 on the downstream sides. Where embankments are made of poor materials, or are likely to suffer erosion from cattle trampling or

wave action, the slopes should be made flatter to suit the circumstances involved. Anthills and solid rock outcrops should be avoided unless there is no alternative. Anthills should be completely excavated and the hole filled in, preferably with soil, or, as a last resort, with treated ant heap material in well compacted thin layers. Rock outcrops will require scraping down and key walls built into the embankment or core.

### 6.9 FREEBOARD

Freeboard for small dams should never be less than 0.5 m with 0.75 m to 1.0 m preferred. Where wave action is likely, additional freeboard may be required. This can be estimated using the following formula:

$$\text{Freeboard height, } H'' \text{ (in m)} = 0.014 (F)^{0.5}$$

where  $H''$  is the freeboard height and  $F$  is the fetch which is the longest distance, in km, across the storage area (usually measured in a straight line from the centre line of the proposed embankment to the tailwater area of the proposed reservoir). The overall freeboard height can then be calculated taking into account the wet freeboard,  $H''$ , (as estimated with the formula above) required to counteract wave action and the dry freeboard (estimated by the engineer) for safety and other factors. The total freeboard is effectively the design depth for the spillway (at its entrance).

### 6.10 CORE DEPTH AND THICKNESS

Cores and cutoffs are expensive items in construction and should be designed to the minimum required according to the FSL, the method of construction and taking into account the comments below. The core will usually comprise the centre of the embankment (refer to zoned dams above) and be designed to reduce seepage to manageable levels.

For designing small dams, as the cutoff can be excavated by hand or small machinery, it need not exceed 2 m wide. For larger dams, cutoffs can be excavated by bulldozer or scraper and then will require a width, usually 4 m, that permits access.

Depths of cutoff should be to good foundation (solid rock or impermeable subsoil layer) or to at least 0.75 times the height of the embankment. When using the latter guideline, if poor material is encountered at the depth for finishing the excavation, the cutoff should be continued until good foundation is encountered. It is very difficult to rectify cutoff problems once the dam is completed and the reservoir full of water so care must be taken in constructing this vital part of the dam and costs should not be compromised. To further ensure that the cutoff is constructed properly, and especially for trenches being excavated by contractors, the supervising engineer should insist that the finished trench is inspected before backfilling commences.

Excavation of any trench requires safety factors to be considered and, for deep trenches, benched or sloping sides or other measures may be required to reduce the possibilities of the sides collapsing. Sloping or benched sides also permit easier compaction and improves the bond between the backfill and the existing ground.



### 6.11 CREST WIDTH

The crest width of an embankment is selected taking into account the size of the dam, the catchment characteristics and topography and whether road or other access will be required across the embankment. In all cases, the embankment crest width should be designed to allow the safe passage of plant and equipment to be used in the dam construction and should be no less than 2 m wide.

Alternatively, and most appropriate to small dams exceeding 5 m in height, a standard crest width of 3 m can be adopted or the formula below can be used:

$$Cw \text{ (in m)} = 0.4H + 1$$

where Cw is the crest width and H is the maximum height of the dam in metres.

Always adopt the widest crest width possible (and flatter embankment slopes) where foundations or construction materials are suspect.

To reduce erosion, all crests should be given a 2.5 percent crossfall to drain rainwater to the reservoir via the upstream slope of the embankment.

### 6.12 SETTLEMENT ALLOWANCE

The embankment will always settle a little after construction and the finished crest should be given a settlement allowance that raises it above its design height at the mid-point by between 5 percent and 10 percent and tapering off to the spillway and valley sides.

### 6.13 STONE PITCHING AND TRAINING BANKS

Stone pitching is usually not necessary, as a good grass cover is normally sufficient to protect the embankment here.

However, occasionally training banks may require stone pitching protection, depending on the climatic regime and likely flood flows. The training banks should be long enough to divert water safely away from the downstream toe of the dam. They should have the same proportions and crest level as the main embankment. Where natural spillways are to be used, the training bank material must be imported from borrow areas as excavation on the site of the natural spillway is not desirable. Similarly, the traversing of plant and vehicles over a natural spillway could lead to problems later in establishing a good grass cover on partially compacted soils and erosion in places where wheel tracks have been made.

### 6.14 SEEPAGE

Seepage is always a potential problem that should be considered at this stage and the designer-builder will have to bear in mind the permeability of the fill materials and of the foundation, the position and flow of groundwater at the site, the type and design of any core or below ground cutoff within the embankment, and the use of drainage devices to collect and safely channel seepage water in the downstream section of the embankment. All earth dams will have some seepage and it is unrealistic not to expect this. If seepage is considered as a potential problem, counter-measures – such as filters, drains, clay blankets and flatter side slopes – introduced at the design stage can reduce any risks to a minimum.

## 6.15 FILTERS AND DRAINS

Filters are expensive and are not normally required for smaller dams.

The aim of all seepage ‘filter’ drains is to lower the phreatic surface (the ‘seepage line’) within the embankment to prevent water from emerging from the downstream slope where erosive and absorptive flows could cause slumping of the material and endanger the whole structure.

Trenches dug into the subsoil beneath the downstream face and toe, at the time of construction, and filled with rock and gravel (the latter helping to limit the movement of finer embankment material into the drains) and continued to a collector drain network at least 3-5 m below the toe line, can safely bring seepage lines down to allow flow out from beneath the embankment.

The configuration of the filter zones, however, will depend upon the type of embankment:

- ➔ In a modified homogenous dam, the filter is generally placed as a blanket<sup>15</sup> of sand and fine gravel on the downstream foundation area, extending from the cutoff/core trench boundary to the edge of the downstream toe and then taken to safe discharge by the toe drains.
- ➔ In a zoned dam, the filter is placed between the core and the downstream shell zone. A longitudinal ‘chimney’ drain of gravel material that collects the intercepted seepage flow and carries it to the base of the chimney and, via one or more transverse drains, conveys the water to the toe drains outside the embankment.

Such drains are essential when seepage risks are considered high – for example, a downstream fill material of fairly low permeability, or a homogeneous dam on an impervious foundation, would always require seepage drains. A saturated downstream area can lead to instability and slippage. If this is significant it may deplete the volume of fill to the extent that the weight is insufficient to resist the forces exerted on the embankment by the water pressure in the reservoir and from beneath the dam. Partial or complete failure may then result.

Other measures to reduce seepage are blankets<sup>16</sup> of impermeable material laid on the upstream face and a rock toe constructed to add weight to the structure (and assist in relieving pore pressure in the downstream section of the embankment). **Figure 10** illustrates a typical clay blanket laid, with a new cutoff, on the upstream face of an existing dam or, possibly, a new dam with poor foundation. Clay blankets can be expensive for larger dams and the option of perhaps less costly filters and drains, to safely take seepage away from the dam and relieve high water pressures within the embankment, should be weighed against the loss of water before a clay blanket is installed.

In established dams, seepage drains can be excavated in the downstream shoulder to relieve water problems but results are always less satisfactory than for drains installed at the time of construction.

---

<sup>15</sup> Never less than 500 mm thick.

<sup>16</sup> 300 mm thick for dams up to 3 m high, 500 mm thick for dams 3-5 m high and 750-1 000 mm thick for dams 5-8 m high.

More details on seepage and countermeasures can be found in FAO guidelines on small dams and weirs in earth and gabion materials (FAO, 2001).

Advice on drainage from an expert is always recommended as the capacity and spacing of drains and the ratio of coarse to fine materials in the filters can be important.

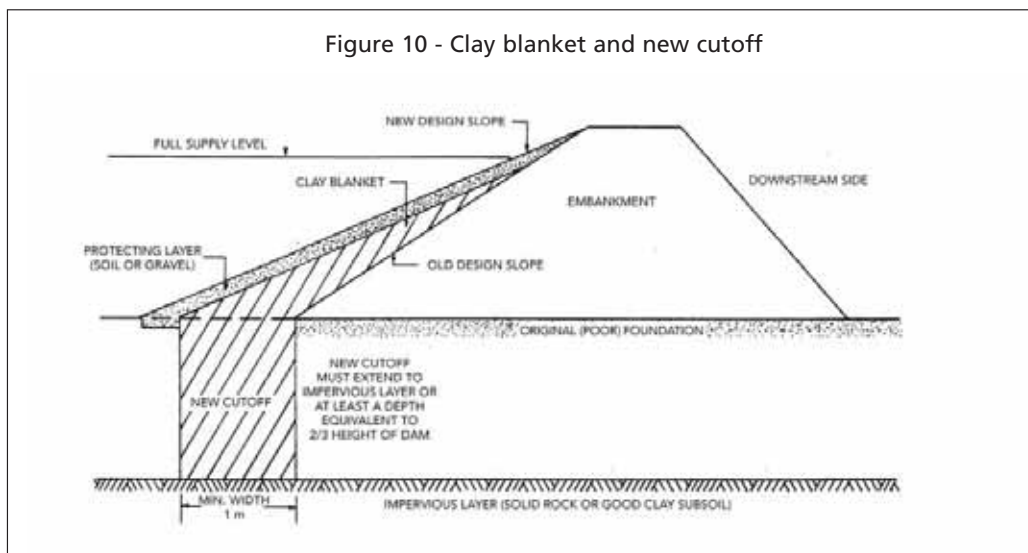

## 6.16 ENVIRONMENTAL ISSUES

It is at this stage that any environmental impact-assessment reports should be completed and any works required to mitigate such impacts be designed and costed. For small dams impacts are usually correspondingly small and may not require significant works. Including a small percentage of the total cost in the bill of quantities and costings (under other works) may suffice to cover any likely costs.

Conserving the catchment before works commence to allow vegetative cover to become well established and thus reduce sedimentation can be considered.

Even if an environmental impact assessment is not required, at the design stage for any new dam, consider the need for environmental flows and releases from the dam – usually in the dry season – to maintain the downstream watercourse in as natural condition as possible.

Provision of drinking water supplies downstream of the dam (using pipes under or through the embankment and simple, sand filters and stand pipes under gravity pressure) will reduce access to the reservoir by people and livestock. Alternatively, wells and hand pumps in the same area may prove suitable and allow local people access to water that may otherwise be lost to seepage.

Fencing the dam and reservoir may be required to prevent access to the embankment and reservoir. Where this is not possible and to reduce the incidence of shistosomiasis, malaria and other water-borne diseases by keeping grass cover around the reservoir and in flowing channels to a minimum (including regular cutting), raising and lowering reservoir levels and removing the possibilities of standing water in and around the dam will help.

Much of the above should become the responsibility of the communities benefiting from the dam and a programme of education (incorporating health and sanitation) on the use of the dam and its resources should be initiated at an early stage in the design/construction process. Involvement of the beneficiaries in any remedial or mitigation works (under any community contribution to the overall works) also engenders a sense of responsibility in using and maintaining the water resource provided.

Dam construction disturbs the landscape around the dam (excavation, clearing areas for storage, accommodation and parking, access roads) and such works should be kept to a minimum. It should be part of any contract for the contractor to remove and store the topsoil of any area to be disturbed and then return such topsoil to the site to allow normal vegetation to re-grow and prevent any subsequent erosion. For borrow areas it can prove difficult to restore them to their original condition but infilling them with waste material from the dam reservoir area and then topsoiling and grassing them will mitigate much of the negative impacts. Alternatively, converting any such pits to fish ponds can be considered (and the pits can be excavated at the time of construction with this eventual aim in mind).



## Dam construction 7

## 7 Dam construction

### 7.1 SETTING OUT THE DAM SITE

This should be completed immediately prior to the start of construction to avoid unnecessary ground clearing and the loss of pegs and benchmarks. Should the original site survey pegs become lost, the dam centre line must be re-established with additional and substantial reference pegs, installed at each end of the centre line, a good distance from where construction will occur. If the original benchmark(s) is (are) not satisfactory another should be established on a permanent site within easy reference distance.

The centre-line pegs should be installed at the ends of the embankment and at every change in ground level. For each change in ground level a ‘mating’ peg (see **Figure 11a**) should be established by level or GPS on the opposite side of the valley, but still on the centre line.

At each peg on the centre line of the embankment, the distances of the toe pegs upstream and downstream are calculated and set out at right angles as in **Figure 11b**.

Unless it is a very small dam, it is advisable to make an extra allowance of 10 percent on the height of the embankment for future settlement. If this is not done at this stage the process can become very tedious and time consuming, as pegs have to be offset from the toe peg or centre line at every construction level. For very small dams (i.e. less than 5 m high) it is common to add a settlement allowance to the top of the embankment at the end of construction.

The toe peg offset distances from the centre line are calculated using the formula:

$$\text{Offset distance (m)} = S \cdot H + 0.5 Cw$$

Where: S is the slope value  
 H is the height of the embankment (m) including 10 percent allowance  
 Cw is crest width (m)

Pegs will be required to indicate the core and crest. If the core is central and has the same width as the crest, the pegs will serve a dual function.

On the spillway side, pegs are located where the spillway cut (if any) begins and ends and additional pegs are placed in an arc along the sides of the spillway channel (see **Figure 11b**). A 15 m interval between pegs is desirable and each should show the depth of the excavation required, note being made of the slope within the spillway itself (usually 1:400) needed to encourage flood water to flow away from the training bank and end of the embankment.

When all the pegs have been installed, and a full pegging layout drawn up, all the ramifications of the project can be discussed with the client and/or plant operator so that any risk of error and opportunity for misunderstanding are minimized and use of equipment and efficiency maximized.

Figure 11a - Mating pegs

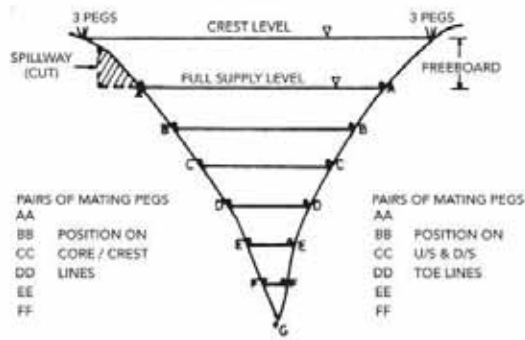

3 Pegs at each end of the embankment  
 peg spillway as required

Figure 11b - Pegging layout

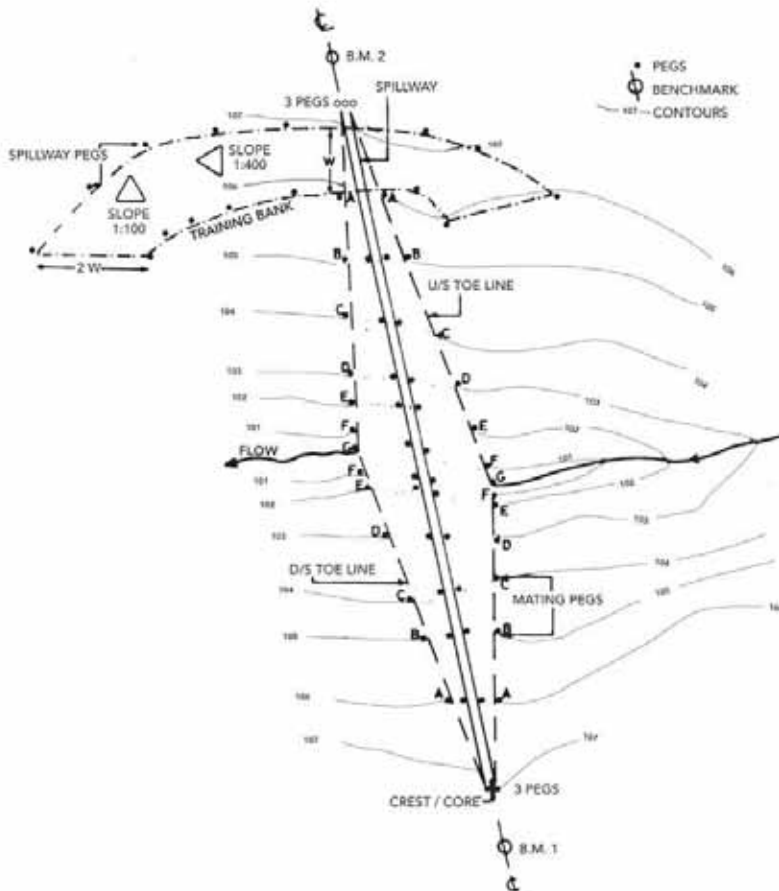

## 7.2 PLANT AND EQUIPMENT

Consideration of what plant and equipment is available, the conditions of operation and distances materials are to be moved, as well as size and type of dam to be built, are the most important factors in determining the plant and equipment to be used.

Bulldozers are not generally recommended as they make it difficult to achieve the levels of compaction and layering essential in any earth embankment. Very small dams made of impermeable material, up to heights of 2 m, can be successfully constructed by bulldozers (calling for settlement allowance of up to 20 percent). Reference should be made to Section 8.6 for more detailed information on this.

Heavy earthmoving machines – such as elevating scrapers and push loading scrapers are not really necessary for small dams unless time is an important factor, short-haul distances are involved and construction rates are particularly economic. For most farm dams, construction by wheeled tractor or crawler drawn dam scoops will be sufficient and, where plant or fuel is not available, ox-drawn dam scoops can be used to construct the embankment. The latter are most suitable for smaller dams and, although they make for a relatively slow process, costs are minimized and an excellent degree of compaction is obtained through the movement of the cattle across the core and embankment. Even tractor drawn scoops are slow and the time element in construction must be considered before a decision to build a dam is made. Dam scoops range in capacity from 0.5 m<sup>3</sup> to 2 m<sup>3</sup>, with the most popular being 1 m<sup>3</sup>, and require a tractor of around 40 KW minimum power to pull them. Considering a typical site with a turn around time of four minutes, one unit would move about 15 m<sup>3</sup>/hour. Working an average of eight hours a day one unit would thus take 83 working days under ideal conditions to move the material involved in the construction of a dam with 10 000 m<sup>3</sup> of earthworks.

Therefore, when farm equipment is to be used on a dam site, scheduling is of paramount importance if the dam is to be constructed within the time period allowed (i.e. often before the next rainy season) without interfering with other farm activities such as land preparation and cultivation.

## 7.3 COMPACTION EQUIPMENT AND TECHNIQUES

The compaction of soil is essential to increase the shear strength of a material to achieve high levels of embankment stability. A high degree of compaction will increase soil density by packing together soil particles with the expulsion of air voids. Comparing the shear strength with the moisture content for a given degree of compaction, it is found that the greatest shear strength is generally attained at moisture contents lower than saturation.

If the soil is too wet, the material becomes too soft and the shear stresses imposed on the soil during compaction are greater than the soil's shear strength, so that compaction energy is dissipated largely in shearing without any appreciable increase in density.

If the soil is too dry, a material compacted in this condition will have a higher percentage of air-spaces than a comparable soil compacted wet. It will take up moisture more easily and become more nearly saturated with consequent loss of strength and impermeability.



A damp soil, properly layered and compacted with a minimum of air voids also reduces the tendency for settlement under steady and repeated loading.

In dam construction, following correct compaction techniques is probably as important as choosing the correct materials. Where laboratory analysis is not available the following guidelines should be adhered to:

- The soil to be compacted must be damp but not too wet and it must be layered along the full length of the embankment in depths appropriate to the equipment used. Farm machinery (e.g. tractor tyres filled with water following a staggered track or small rollers) and hand methods are usually only sufficient to successfully compact layers 75-100 mm deep. Heavier plant such as sheepsfoot rollers (ideal for clayey soils), vibratory and smooth wheeled rollers (ideally for sandy soils) can work with layers up to 200 mm thick and obviously are preferable where large quantities and widths require compaction.
- Where soil moisture content is low, borrow pit irrigation always results in a more uniform distribution of water in the soil to be compacted. It is also more economic than adding water to the construction surface and often assists working of the soil by the excavators. Time is saved on the embankment by avoiding having to water the surface between layers. Judicious planning with ripping and ploughing of the borrow area before irrigation and allowing the water to soak in over one or more days (depending on climate, soil type and quantity of water applied) before excavation will assist the development of uniform moisture contents in the earth fill materials.
- Always adopt compaction techniques that will reduce the gross depth of any layer by at least 25 percent.

### 7.3.1 Rollers

**Sheepsfoot rollers** can compact layers of soil up to 200 mm deep gross (i.e. about 150 mm after compaction) and satisfactory densities can normally be obtained with 6-12 passes at a roller speed of 3-6 km/h when the soil moisture content is right. It is important to keep these rollers clean as soil collecting between the feet will reduce compacting ability. Sheepsfoot rollers are more effective than other rollers in compacting drier clay (but will require more passes) and will churn and blend the soil which is useful in distributing water throughout the construction surface when borrow pit irrigation is not possible.

**Vibrating rollers** are more suited to the compaction of sandy soils and where resulting very high densities are required. In dam construction their usefulness is usually limited to small-scale work such as narrow cutoff compaction, trench work and similar.

**Rammers and plates** have much the same application and are used where space is a limitation and in specialized work such as trenches, behind concrete and around pipe work.

**Smooth wheeled rollers** are more efficient at reducing air-spaces and continue the compaction of lower layers of the embankment through new layers to a greater extent than comparable sheepsfoot rollers. On similar layer depths, and at the same speed, a smooth wheeled roller would probably require slightly fewer passes to obtain similar soil densities when compared with sheepsfoot rollers. However,

the latter often prove more appropriate in use for dam construction as their lighter weight and versatility allow them to be pulled by farm machinery on a variety of surfaces.

On clay soils, smooth-wheeled rollers can form seepage paths between layers of soils laid on the embankment. If a sheepsfoot roller is not available to compact such soils, the layers of clay should be reduced in gross depth and final surfaces roughened (by harrowing or similar) to permit a good bonding between compacted layers.

## 7.4 SITE CLEARING AND PREPARATION

### 7.4.1 Base of the dam

All trees and roots, grass, grass roots and topsoil must be removed. Once the trees have been removed (by hand usually) the dam scoop or scraper can be used to remove about 100 mm of top soil which can then be left in a position from which it can be later retrieved to dress the completed embankment or other disturbed areas.

### 7.4.2 Borrow areas

Borrow areas should have been demarcated according to usefulness some time previous to the start of construction with, if possible, analysis of soil samples being undertaken by a local soils' laboratory. For smaller dams, a visual or rough physical assessment may suffice.

The high percentage organic material top layer must be removed and put to one side for future use. Although borrow areas within the proposed reservoir are desirable, care must be used to make sure that permeable layers are not exposed by the removal of impermeable soil above, as this process, if conducted close to the embankment, could lead to seepage problems later. Also, no excavation should occur nearer than 10 m from the toe of the embankment.

Excavated soil (from the borrow pit) must be frequently monitored to check that its quality and moisture content has not changed and that it is still suitable for emplacement in the embankment. The core and cutoff trench require good quality clay, the downstream shoulder poorer and coarser material (drainage is important) and the upstream shoulder a clay soil of some impermeability.

Compaction of the core and cutoff trench is important and the amount of compaction required in all sections will vary from site to site according to the soil quality. Generally, drier and lower clay percentage soils require more compaction and vice versa. Soils of around 20-30 percent clay are ideal as core material and those of lower percentage clay for the upstream shoulder.

## 7.5 SETTLEMENT

As the dam settles, the crest should fall close to horizontal. It is important to check this by survey every few months in the first years of operation to ensure over- or uneven- settlement does not occur. If this does occur, remedial measures (filling by topsoil and grass is usually sufficient) will be required to restore the crest to its design level.

If poorer and/or coarser soils are to be used, some increase in the settlement allowance considered at the setting out stage may be necessary. In most cases this increase should not be more than 15 percent overall.

## 7.6 SPILLWAY

Natural spillways are generally best for all earth dams but often some degree of cut is required to obtain the necessary design slopes. In all cases the movement of machinery over the spillway area should be minimized to avoid over compacting the existing soil, establishing track ways (which could lead to erosion later) and destroying any existing grass cover. Where a cut is required it should be kept to a minimum and, unless unavoidable, should not involve complete removal of the topsoil. If the latter does occur, over cut will be necessary, the additional depth being required because good quality topsoil and grass cover will have to be placed once the desired profile has been attained. Any large volume spillway cut should be done at a time when the excavated material (if suitable) can be included with the material being moved to construct the main embankment or reserved to fill in borrow pits. Smaller volumes of cut material can usually be included in the training bank.

## 7.7 CONSTRUCTING THE EMBANKMENT

### 7.7.1 The core/cutoff trench

As this is the most important part of any embankment, great care is necessary in the excavation, fill and use of material.

Width and depth should have been determined at the design stage. Width (2 m minimum) will often depend on the equipment used in the excavation and also on the size of the dam.

The minimum depth necessary will depend on site conditions but in all excavations the cutoff trench must be taken down to good quality impermeable material such as clay or solid rock or to a minimum of three-quarters of the dam's crest height. If rock is located and is generally good, it is permissible to fill any cracks or fissures with compacted clay or mortar, provided they can be fully cleaned and traced to ensure seepage paths will not develop later. If an impermeable layer of sufficient thickness has not been reached and the trench depth is to the required  $0.75H$ , the cutoff trench excavation can stop only if the material encountered is not of a coarse or gravelly nature (as often occurs in streambeds). If permeable material is found it is vital that the cutoff is taken through it to a depth sufficient to find more impermeable material.

Before backfilling, the excavation should be checked to ensure that the conditions above have been complied with. Short cuts taken at this stage can prove costly later and seepage through the embankment can become excessive if the correct depth into the correct material is not achieved. A little extra time and care in the excavation of the core is usually worthwhile.

Other requirements such as coffer dams, special compaction, dewatering equipment and safety provisions in the trench should be considered before excavation starts, to allow the work to be carried out efficiently. An assessment of the site condition, for example to ascertain groundwater levels, at the design stage would allow such special provisions to be included in the cost estimates.

Once the excavation has been checked and found satisfactory, backfilling can occur. The best clay soil should be used and compacted in layers no more than 75-100 mm thick (50-75 mm is best), throughout the length of the trench. Although compaction can be achieved by staggered wheel tracks (if tractors are used, fill the tyres

with water), it may be more desirable to use hand labour and tamping devices (75-100 mm diameter wooden poles are usually sufficient), or towed equipment (where thicker layers are permissible), to obtain the high levels of compaction required. For broader cores, sheepsfoot rollers or vibrating compacters may be more economical.

Water bowsers or irrigation equipment may be useful in assisting compaction.

Ant heap material or cracking clays are not recommended for core filling but if the former is used it should be chemically treated and in all cases kept as far as possible below the ground level sections of the core (which should remain wet throughout the year).

### 7.7.2 Embankment

Once the cutoff has been brought up to ground level, the embankment can be constructed. If necessary, and usually because of time limitations, it may prove prudent to construct the cutoff some time before the rest of the dam (i.e. during the previous dry season ensuring the works are protected from erosion).

The embankment can proceed with careful and continuous monitoring of the soil types being used to check that the right soil is placed in the appropriate section. The core is continued up through the centre of the wall as the other sections are placed. Because of the width involved, hand compaction may not be feasible and other methods will have to be used. As mentioned, no layer should exceed the recommended depth and, if the tractor/scrapper operative proves incapable of maintaining such a standard, graders or labourers with shovels and rakes may be needed.

The removal of the soil from the borrow areas can be assisted by ripping or irrigating the area involved (avoid over-watering which could lead to traction problems). The latter is especially desirable for core and upstream sections where the soil, if used wet, may be more readily compacted.

At stages determined by the designer/supervisor, the embankment as constructed should be surveyed to check that the slopes conform to design limits. If there is any variation, remedial measures will be necessary:

- If the slopes are too flat a berm could be constructed to allow an overall slope closer to the design.
- If the slopes are too steep, rectification is more difficult as, before earth can be placed to flatten the slopes, keys are required in the existing face to reduce the formation of slip surfaces between the older and newer material. In the latter case, although the slope may be corrected in this way the stability of the dam is never as good as it should be, since it is difficult to obtain the same compaction levels and cohesion as in the original structure.

It is better therefore to avoid such problems by careful and frequent monitoring of the structure as it takes shape, especially at the beginning of the work when operators and other staff are more prone to make mistakes. Guide boards and pegs can assist at this time with boards cut to the correct angle to be laid on the slope with a spirit level or plumb bob to show horizontal or vertical.

When the embankment is at the correct height it must be surveyed to check in particular that the crest has been built slightly convex with more soil laid in the centre where the most settlement will occur. The crest should have a slight

slope (crossfall) towards the upstream side of the embankment to permit the safe drainage of rainwater to the reservoir rather than the downstream slope. Over the next few months, and finally after one year, the embankment should be rechecked to assess settlement and to allow the placement of soil at any sections that settle to below horizontal. The spillway should be checked to prove the design slopes were adhered to. If large flood flows occur, or are expected, stone pitching or concreting of the end of the embankment and one or both sides of the spillway channel may be necessary to reduce the risk of erosion.

It is very important that good grass cover, preferably of creeping grass type, is established on both the embankment and the spillway before the likelihood of heavy rains. This could mean constructing most of the spillway before work on the embankment itself starts, ideally at the end of the previous rainy season when water for establishing grass is available.

Either way, the last soil layers to be laid on the embankment, and on any spillway cut sections, should be of good quality topsoil so as to encourage rapid and dense grass growth. Manuring and irrigation may prove beneficial. To minimize erosion caused by people and animals the embankment should be fenced and gated and, in some cases, special protected pathways for watering livestock should be provided to keep animals well clear of sensitive areas. If erosion does occur, particularly at the early stages, much time and effort can be saved by prompt remedial action. After any heavy rainstorm the dam should be inspected. Any rills or gullies filled in and replanted with grass before the situation becomes too advanced. Where soil and grass cover are difficult to establish, wiring of the topsoil and vegetation may assist in re-turfing with suitable sods in any holes that occur.



Special cases 8

## 8 Special cases

### 8.1 INTRODUCTION

With specialized technical advice and supervision, earth embankments can be successfully constructed on sites that are likely otherwise to cause difficulties. If it is considered that the risks and extra expenses involved are worth taking, dams can be constructed on problematical sites by following the normal procedures already outlined but modifying them to suit each particular site. If civil engineering advice and expertise are not available, the height of the embankment should be kept to the minimum commensurate with the water storage required.

### 8.2 EARTH EMBANKMENT ON ROCK FOUNDATION

In some cases – and where there is no risk of the embankment sliding on the rock surface – an earth embankment may be cheaper than a masonry dam or weir. The construction of such a dam is straightforward and many of the procedures described previously are involved. However, there are one or two items whose importance must be stressed.

The rock on which the embankment is to be built must be solid throughout its length (minor cracks should be traced, cleaned out and filled in with concrete) and be of a width sufficient to provide a good base for the wall. It is better if the rock width is greater than the required base width, but this is not absolutely necessary for a successful dam to be constructed. Some investigation will be needed to ascertain that the rock extends to a depth great enough to act as a cutoff to seepage that may occur.

Once proved suitable, the rock should be cleared of all weathered or loose material. A low and wide key wall is then constructed along the proposed dam length (usually at or near the centre line) to minimum dimensions of 0.6 m wide and 0.4 m high. Immediately before the bricks, stone or concrete are placed, the rock foundation is prepared with a cement wash (cement and water mixed to a cream consistency) to assist anchorage. Anchor bolts or cutting of a trench into the rock, if equipment is available, will be of assistance. The key wall should not be 100 percent solid, but should have, at regular intervals, small gaps or pipes that will allow passage of seepage water through it without significantly affecting its structural abilities.

The central core of the embankment is to be beside and on top of this key wall and it is usually necessary to place the initial layers each side of the wall, to the design width, by hand. Following normal procedures, the best clay soil available should be used and laid in layers, 50-75 mm thick and well compacted by wetting, careful ramming and/or rolling. Once the core has reached to above the key wall, placement can follow using machinery and the embankment's construction can proceed as already outlined.

Alternatively, the core can be placed first to a height exceeding 0.5 m and then a central section of 0.6 m wide excavated from it to the rock and the key wall constructed within this trench.

If settlement of the embankment is likely to be significant or of a nature that could cause cracks in the key wall (differential settlement can lead to a rigid structure being deformed to such an extent that fractures occur), some form of reinforcing is advocated to strengthen the structure. Fencing mesh or reinforcing wire placed in the wall is usually adequate.

### **8.3 EARTH EMBANKMENT USING POOR EARTHWORK MATERIAL**

If good clay soils are not available, an embankment can be constructed safely, if certain modifications to the design are made.

The core should be placed using the most impervious material available; any heap material can be considered only as a last resort and must be treated before and during backfilling. Cracking or swelling clays may be used but it is advisable to mix them with coarser soil as all that is required of a core material is that it has sufficient clay in it for binding and rendering the mass as plastic and as impervious as possible. If it is likely that this material is to be used the dam owner should be advised that the embankment should not be allowed to dry out or fill up too quickly, and should be kept as full of water as is possible.

The embankment itself should be designed with as flat a slope as can be economically entertained, but no steeper than 1:2 for the downstream face and 1:2.25 or 2.5 for the upstream. As is normal, the coarser material should be laid on the downstream side of the core.

### **8.4 AN EXISTING EMBANKMENT WITH SEEPAGE PROBLEMS**

Excessive seepage from a dam can indicate serious problems. Dirty water seeping from the downstream face is an indication that soil material is being eroded within and being carried from the embankment. This is usually associated with poor soils and poor compaction in the embankment or in the cutoff/core and remedial measures can be put in place that will reduce seepage to manageable and safer levels.

To improve the impermeability of the embankment, a clay blanket of 0.25-1 m thickness should be laid on the upstream side of the core (refer to **Figure 10**). Puddling of the reservoir floor immediately upstream of the dam, and gravel drains and filters placed on the downstream side, are recommended. More details on measures to reduce seepage and improve drainage are provided in *Finishing Works*.

Once a dam has developed seepage problems such as this it must be regularly checked – installing piezometers to measure phreatic levels in the embankment is recommended – to assess whether seepage is being controlled and whether more problems are developing, and if so how important they are. Throughout the dam's life continual inspection and maintenance is necessary, especially in the first few years after the remedial work has been completed.

### **8.5 MASONRY CENTRE SPILL DAMS**

Masonry centre spillways are normally required when there is no alternative but to spill floodwater over a central portion of the dam. For most farm dams the centre spill structure can be a gravity weir founded on rock and constructed from masonry or concrete or, if founded on less rigid material, can be constructed from gabions (see details in the FAO publication on small dams and weirs in earth and gabion materials (2001)) with headwalls each side to key the spillway into the earth embankment.



Figure 12a - Inside face of typical stepped headwall

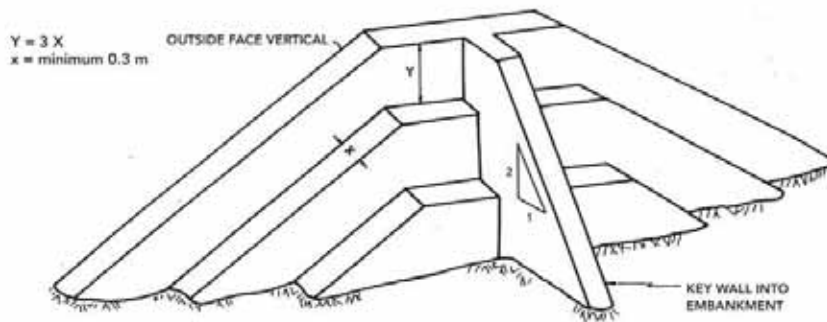
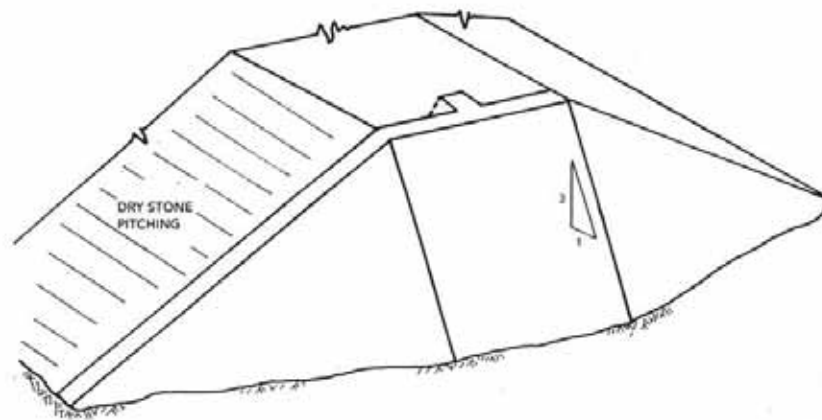

Figure 12b - Exterior face of typical battered headwall



An example of a suitable headwall is shown in **Figure 12**.

Spilling must be done on to rock or into an energy dissipater (a stilling basin) and suitable provision made downstream to counteract any erosion risks in the stream-bed. River training through use of stone-pitched or concrete channels and gabions may be necessary in extreme cases.

For larger dams, civil engineering advice should be sought to ensure the stability of the centre spill structure.

## 8.6 BULLDOZER DAMS

Although not recommended as sound and long-lived structures, bulldozer dams can provide cheap and useful ways of storing small quantities of water for such purposes as stock watering, water planting, fish farming, garden irrigation and domestic uses.

The use of bulldozers to push up a wall of soil across a watercourse is not advised. Any correctly built bulldozer dam should follow the procedure below:

- Maximum height 4 m.
- Minimum base width (for this 4 m height) of 20 m and including a crest width of 3 m.
- The foundation area must be cleared of all organic material and topsoil to a maximum depth of 150 mm.
- The foundation must be well compacted and should have key trenches excavated if necessary.
- Earthworks' material is pushed by bulldozer, from the reservoir side only, and spread over the complete length of the dam in layers up to 150 mm (less is better) thick.
- Each layer is compacted using the best means available (i.e. cattle, tractor tyres full of water, labourers using poles, etc.).
- The side slopes must be no steeper than 1:2 and flatter is better.

A spillway is always needed for these dams unless they are expected to fill from seepage or directly from rainfall as 'dewponds' in the United Kingdom and 'haffirs' in Ethiopia and Eritrea. A small pipe, installed in a trench on one side of the dam at a suitable elevation (0.5 to 1 m below full supply level), may suffice unless streamflows are high. For the latter, an emergency spillway on one bank may be required. It is important that this spillway is truly horizontal at the embankment, is well grassed and the end of the embankment and the toe of the dam protected from erosion by rip-rap, stone pitching or gabions.

The keying of such embankments to boulders or anthills is not recommended as the boulders are likely to provide poor anchorage and have attendant seepage problems and anthills will lead to termites moving into the dam to cause major problems after a few years.

Maintenance is a continual issue with bulldozer dams, but with regular inspection, especially after heavy early rains or floods, this can be kept to a minimum.

If dry season water supply is essential, or evaporation rates are high, excavation of the deepest part of the reservoir to produce a total depth of four or more metres may be worthwhile. In any case, to reduce risks of endangering the dam's stability, excavation should not take place nearer than 10 m from the upstream toe of the dam and well clear of any spillway section.

## 8.7 DAMS IN LOW RAINFALL AREAS

Where, because of low rainfall, it is not possible to establish and maintain grass cover on the spillway and embankment, other measures to prevent erosion should be taken.

The spillway should be stone-pitched throughout with large stones, well wedged (refer to **Figure 3**), and with the long axis of each stone at 90° to the ground surface. Any spaces between stones should be filled with soil and planted with suitable creeping grass.

The embankment itself can be stone-pitched but, as this is likely to be costly, it may be more feasible to stone pitch or put rip-rap, correctly sized and placed, on areas of high risk such as the ends of the embankment and areas likely to be affected by

wave action, and then to place loose stone and rock on the rest of the embankment. At the design stage it may be necessary to adopt flatter slopes to facilitate this.

Irrigation of the spillway and embankment before the rainy season to encourage creeping grass growth between the stones should be advised where possible. Again, regular inspection and maintenance of such dams is necessary if their lives are to be maximized and repair work is to be minimized.

### 8.8 ESTIMATING CAPACITY IN A RAISED DAM

The capacity of a new dam or a raised dam can be estimated using survey methods and the formula:

$$Q = \frac{LTH'}{6}$$

Where aerial photos are used and the reservoir surface at full supply level is calculated and the deepest point known, the formula  $Q = \frac{H' A'}{3}$  can be used.

However, in the case of a raised dam it may be possible to use the formula  $Q = k(H')^3$  if the following is known:

- old capacity (Q), in m<sup>3</sup>
- old H' (deepest point at FSL), in m
- new H' (deepest point at new FSL), in m

Then, by calculating factor k and including it in the equation  $Q = kH'^3$ , the new Q can be readily determined without recourse to time consuming and occasionally difficult survey methods.

For example, if:

$$\begin{aligned} \text{old } H' &= 10 \text{ m and } (H')^3 = 1\,000 \\ \text{old } Q &= 200\,000 \text{ m}^3 \\ k &= \frac{(H')^3}{Q} = 200 \end{aligned}$$

Therefore if:

$$\text{new } H' = 15 \text{ m}$$

Using the above formula:

$$\text{new } Q = 200 \times 3\,375 = 675\,000 \text{ m}^3$$



Finishing works 9

## 9 Finishing works

### 9.1 INTRODUCTION

When the embankment has been constructed, and all major outlets and drains installed, the dam can then be finished off. It is quite important that the training banks along the spillway sides are well established with grass cover and protected with other erosion prevention measures before the spillway is to be used. Rains on an unprotected embankment and water flow through an incomplete spillway can, at the least, cause minor rills and gullies and, at worst, destroy the structure altogether. Therefore, when most of the heavy earthmoving and other work has been done, it is vitally important not to neglect the minor finishing touches that, if delayed, can negate much or all of the work already performed.

Even when finishing works have been carried out properly, and at the right time, minor problems with erosion and settlement are commonplace. Because of this a programme of regular inspection and maintenance has to be instigated to ensure that no major hazards arise.

The remainder of the site should not be ignored. Areas used for storage, accommodation or the access and parking for plant and equipment should be restored as much as possible to their original condition. Topsoil and grass reserved at the beginning of the works can be spread on such areas to allow vegetation to re-establish itself and erosion risks of exposed soils to be minimized. Borrow pits and other areas used to excavate materials should also be filled in as much as possible (using any leftover or unused materials) and then grassed unless they can be converted to water-storage ponds.

### 9.2 INSPECTION REQUIREMENTS

At the time of siting the dam it should have been made clear to the local community/dam owner that to maintain the dam in good condition and to prolong its life as a sound, useful water resource, competent and timely inspection and maintenance are going to be required.

All dams must be inspected at least annually. In dry season climates the best time to carry out this work is before the beginning of the rainy season, when most of the dam and its reservoir area can be seen. Time after the inspection (and before the rains begin) must be allowed for to complete any remedial or repair work.

All dams with grass spillways must be visited after every heavy rainstorm and flood. This is most important at the beginning of the rainy season when, because of limited grass cover, erosion risks are highest.

All new dams that have not completely stabilized and settled require frequent visits and, again, the beginning of the rainy season is an important time, especially if a grass cover has not been established. After the first year or so, a more routine inspection programme can commence. Initially visits (which will vary from site to site) should not be less than twice a month and after every rain or flood.

### 9.3 TRAINING BANKS

Training banks are required along one or both sides of the spillway to keep flood-water away from the downstream toe and shoulder of the embankment and within the channel. Training banks are often constructed without a core, but often will use the same slopes as the main embankment. However, the design can vary according to site conditions and crest widths and heights can be reduced as required. In construction, care should be taken to avoid traversing the spillway and no earth should be removed from the channel bed for this bank unless cut is required to form the spillway.

Concrete or stone pitching at the end of the main embankment and along the inner sides of the training banks may be advisable.

### 9.4 OTHER WORKS

In finishing the main embankment, the crest should be given a slight downward slope towards the reservoir so as to encourage runoff towards the reservoir and the less erodible upstream section of the embankment. The accumulation of water on and in the downstream shoulder must be avoided.

Tidying up, cosmetic work and other minor works can often be left to the farmer/dam owner/community rather than the contractor. These activities prove unnecessarily costly if heavy plant is to be used. Such finishing work should include the following:

- Grass planting (spillway, outfall and embankment)
- Sodding spillway (cut sections) and around stone-pitched areas
- Stone pitching spillway (low rainfall areas)
- Finishing trickle flow outlet and the outfall pipe arrangements
- Digging seepage drains
- Fencing
- Fertilizing and irrigating grassed areas
- Stone pitching training bank and embankment
- Concreting high erosion risk areas

Last, if gauges at the spillway, or other outlets or reservoir depth indicators are required these should be installed at this time (when they cannot be damaged by plant and traffic associated with the construction). Similarly, signboards and any safety advice notices should be considered at this time.

### 9.5 MAINTENANCE PROCEDURES

A farm dam is usually to be found in its best condition immediately after construction. To keep it in good order it is very important that maintenance is carried out regularly.

Preparation of a check list of activities to be completed annually (or more frequently) should be prepared and maintained as record of maintenance activities and works carried out.

This check list should include the following:

### 9.5.1 Grass cover

It is essential that a good creeping grass type (i.e. kikuyu, couch or star grass) is established on all bare earth surfaces as soon as possible after construction and preferably before the first heavy rains. At the time of construction all topsoil removed from the site (i.e. for foundation or spillway excavation work) should have been stockpiled and the latter used to finish off the dam with a good last layer (50-75 mm deep) of soil. This can then be mixed with manure or fertilizer (300 kg/ha of nitrogenous based fertilizer) and planted to grass. Where water is available, irrigation will greatly assist the establishment of a grass cover which will reduce erosion and related problems to a minimum.

In harsher environments or where soils used as earthworks' material are likely to be susceptible to erosion the designer/engineer can adopt one of several short-term solutions:

- Cover soil with a layer of gravel or loose light stone pitching (rip-rap in wet or wave action areas) which, if there is any, the grass can grow through. Where gravel and stone is expensive or difficult to find such protection should be limited to steeper slopes. If these areas are lightly irrigated before the rains start, the material will be bound together by the growing grass.
- Plant a short-lived cover crop, such as rye grass, pigeon peas or similar, that will grow rapidly and provide limited protection to the embankment and spillway while a creeping grass establishes itself beneath. Cutting the crop before seeding takes place is necessary.
- Use a hemp or similar net-like fabric that can be pinned or anchored to slope faces and will provide some protection to newly emergent grass and the soil beneath when runoff is severe.

An expensive and often last resort is to adopt flatter slopes (3:1 or 3.5:1) at the design stage and thus reduce the velocities and spread of the runoff more evenly across the embankment.

Once a grass-cover has been established it should be maintained in a dense, short condition – this is obviously difficult in climates with long dry seasons but can be assisted by:

- Irrigation – where water is scarce reserve a supply for use when temperatures begin to rise and just before the rainy season begins. Either use an irrigation system or a water bowser to supply around 25 mm or more of water per week.
- Cultivation – do not burn off grass as this will encourage taller clumping varieties to grow at the expense of the preferred shorter, creeping type. Either cut the grass or allow limited but well-supervised grazing; being careful to avoid damage and tracking across the embankment or spillway.
- Fertilizer – a careful application of manure or fertilizer before irrigation or the start of the rains will prove helpful.

### 9.5.2 Fencing

This is vital to keep livestock, people and vehicles off sensitive areas such as the spillway, the outfall and the embankment. Good fencing will assist in maintaining the grass-cover, will minimize erosion and control access to the dam and reservoir area.

Most gullies in the spillway areas and on embankment slopes are started when rainfall and the subsequent runoff concentrate in depressions caused by footpaths, vehicle tyres or animal tracks.

Therefore, keep all fences in good order, check all posts during the annual inspection and inspect the wire whenever possible. The local community or dam owner should provide the fencing at the time of construction and must be made aware of the importance of maintaining it.

### 9.5.3 Settlement

However well the dam was built, it will always experience some settlement. Most dams settle out in the first year or so after construction. Invariably most settlement occurs at the highest point of the dam where mass is greater and other pressures highest.

At the time of construction a settlement allowance should have been incorporated on the top of the embankment. At every inspection the crest must be checked to ensure it remains horizontal and that no low spots have developed. All over-settlement must be attended to with backfill and additional monitoring. If this is neglected, and should either the crest level fall overmuch, or an exceptional storm lead to backing up of floodwater from the spillway, the dam will overtop, water will concentrate in the low spots and serious damage result.

Unusual settlement in an older dam can indicate foundation movement or removal of embankment material by seepage or erosion. Always seek expert assistance when this occurs.

Another form of settlement can arise when, due to poor construction techniques, the core has been compacted comparatively more than other parts of the embankment. **Figure 13** illustrates this. The upstream and downstream sides or shoulders of the embankment settle more than the core as they are less well compacted and, as the foundation is firm (and it cannot fully absorb the differential settlement), cracks appear along the crest edges as the settlement takes place. These cracks do not represent a serious problem and can usually be treated by ramming in damp soil complete with grass as soon as they develop. It is important to prevent water entering such cracks (otherwise erosion and waterlogging will follow) and in the rainy season it may be necessary to sandbag the area to minimize runoff. When large, deep cracks appear on older dams (indicating foundation movement or slumping of either shoulder), the reservoir water level must be lowered and expert assistance must be sought without delay.

### 9.5.4 Seepage and drainage

All earth dams will leak to some extent and seepage only becomes a problem if it endangers the embankment – either by encouraging erosion in the downstream area or by causing waterlogging of the dam and thus affecting its stability. Dirty water seeping from the downstream face of any dam is cause for concern. As finer materials are eroded, and carried out of the embankment, this could lead to piping or slumping in the structure.

At the time of construction and, particularly if the dam does not have a dry, well-drained downstream foundation area, drains should be installed before the embankment is built. If this was not done and seepage has become excessive, the following may reduce the problem:



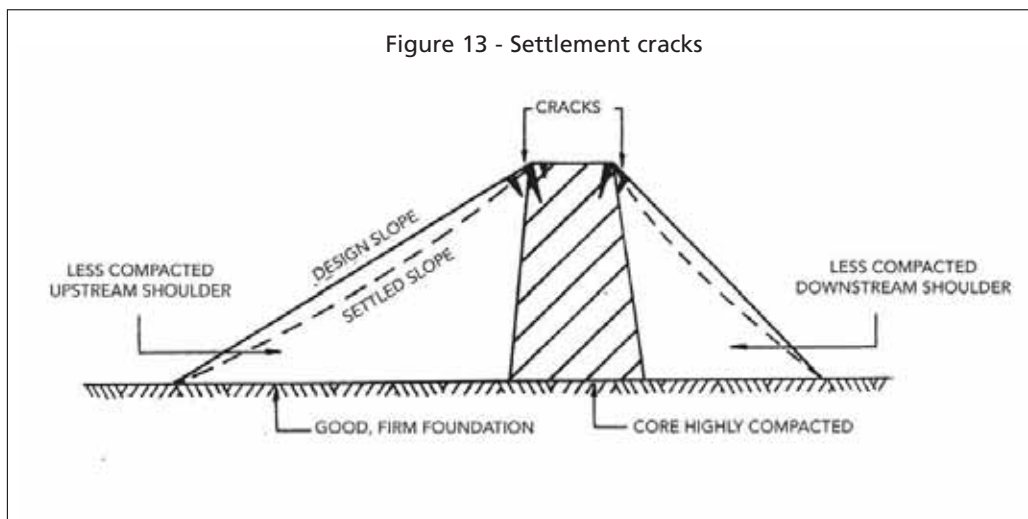

- Minimize the seepage by sealing the upstream face and reservoir areas. This can take the form of a 500 mm thick clay blanket laid and compacted on the areas with highest water pressure and protected (from erosion and drying out) by topsoil or gravel. If the dam water level can be lowered, construct a new cutoff beneath the upstream toe. **Figure 10** illustrates an example where both a clay blanket and new cutoff have been installed. In both cases the most impervious clay available should be used and should be laid on the upstream face once it has its layer of topsoil removed and been disked or ploughed to encourage a good bond between the old and new surfaces. Once installed it is important to prevent damage to the new surface by deep-rooting plants or burrowing animals. Obviously, this work can only take place when the reservoir is dry.
- Trench into and beneath the downstream toe to relieve water pressure in this shoulder of the embankment – always ensuring that the excavation work is safe. Backfill the trenches with rock and gravel to allow continued drainage and restore the embankment to its original slope with a final layer of topsoil and grass. All drains should feed a central collector drain which is then taken to a safe, non-erosive discharge area further downstream. This work is best carried out during the dry season but can be done as required if the dam is in danger. In both cases, if possible, the water level in the dam should be lowered before these operations are completed to reduce risk.

## 9.6 TREES AND BUSHES

Do not allow trees, bushes or other deep-rooted plants to grow anywhere near the embankment, the spillway and its outfall. Keep all parts of the dam clean with a low grass cover to protect against erosion and assist inspection and maintenance. Trees on the embankment do not help stabilize the soil and their roots will eventually reach to water. When dead and decomposed, pathways for insects, animals and water are then formed. Therefore, remove all trees and bushes before they become established. In a situation where large, old trees have been allowed to establish themselves on the embankment they should be removed when the upstream water level is low. The trees should be cut as low as possible and, if the stumps cannot be excavated, they should be soaked in petrol and burnt or treated with chemicals to

allow their rapid decomposition. All remaining material and roots must be removed and all excavation works backfilled, compacted and restored to the design slope with topsoil and grass cover.

Trees or bushes on the spillway will alter its hydraulic characteristics and can reduce its capability to safely carry away flood flows. Such flows are encouraged to concentrate in channels (and thus may lead to erosion) rather than to spread evenly over the full width of the spillway (thus maintaining lower velocities and avoiding turbulence). Again, tree roots do not assist the stability of the soil.

## 9.7 EROSION

This is a common problem on any dam where grass cover and fencing have not been maintained. If not rectified at an early stage gullies can form and soil can be lost to runoff and floods leading to stability and seepage problems.

The main causes of erosion are:

- Lack of suitable grass cover.
- Tracking by livestock and people on the embankment and spillway.
- Low flow channels developing on the spillway.

All erosion should initially be treated by restoring the affected areas to their design dimensions, (i.e. backfill, compact and grass all eroded sections) and re-fencing as required.

Low flow channels in the spillway are often associated with dams constructed on perennial rivers where, during the dry season, low flows are allowed to meander across and down the spillway (especially on spillways that have not been maintained) and have concentrated into small gullies. The best solution to this problem is to install an overflow pipe beneath the embankment at the time of construction with a protected inlet location just below spillway level. This will carry all normal river flows while the spillway is reserved for floods only. However, if such an overflow is not available it is unwise to excavate into the embankment once the dam has been built; therefore it is better to modify the spillway to cater for normal flows. Excavate and line a small channel with sufficient capability to carry the estimated volumes of water involved and ensure (as in any outlet) that it is taken to safe, non-erosive discharge.

A disadvantage of this is that after every flood these channels require checking and de-silting and, where such measures have been instigated, special attention must be paid to their condition at every inspection.

Where spillways have been damaged by flows, whether small or large, it is important to restore them to their design dimensions – backfill, compact and grass all low spots, protect eroded sides with stone pitching or masonry and ensure all outfalls (discharge areas) are safe with flat, broad slopes to allow non-erosive disposal of flood waters.

The construction of concrete sills at the entrance, and at regular intervals down a grass spillway, will ensure a horizontal surface is maintained for the channel bed, will limit erosion to within each section and act as energy dissipaters. Each sill should be a minimum of 0.3 m wide and 0.3 m deep and be well keyed to the sides and the bed of the spillway. Depending on the slope, they can be positioned at

intervals of 30-50 m down the spillway. As gullies often develop first in the outfall area (usually the result of too steep slopes, restricted discharge area and poor maintenance), sills will assist in restricting erosion that may move back up the spillway if remedial work cannot be immediately undertaken.

### **9.8 TERMITES AND ANIMAL BURROWS**

With a regular, competent inspection programme, ant or animal activity should never be a problem. Any ant workings found should be suitably treated with a recommended fumigant, dug out and the excavation backfilled in layers with good material and the careful use of a long-life insecticide. All slopes must be restored to their original design shape. If, the excavation required is large (usually because of no or poor inspection), always seek expert advice and never attempt to carry out the work in the rainy season or if the dam is full.



Repair work 10

# 10 Repair work

## 10.1 INTRODUCTION

Only carry out repair work that is simple, straightforward and falls within your capability. For difficult, large-scale or technically complex work always consult a qualified engineer. Poor repair work can be dangerous and lead to more serious problems developing later in the dam's life.

Before any repair work is begun always try and ascertain and rectify the cause of the damage so that the problem will not recur. Modes of failure can be attributed to four basic causes:

- Overtopping: can be counteracted by conservative spillway design, generous freeboard allowances, and avoiding areas where landslides could affect the reservoir.
- Slope failure: avoid by following correct design and construction procedures based on site investigations and materials' analyses.
- Spreading of the embankment base: minimize risk by avoiding poor foundations, the adoption of flatter side slopes and reducing the height of the dam.
- Piping: avoid the development of piping by following correct design and construction procedures, filling of cracks as they develop (normally after settlement of a new dam) and the introduction of drainage downstream through filters and toe drains should seepage become excessive.

Problems can develop from structural defects associated with poor design and construction and can often have catastrophic results when the dam breaches or collapses. Non-structural defects such as too small or too large catchments and spillways relate directly to faults in design. The major results of these defects are outlined below along with remedial measures that can be taken.

## 10.2 STRUCTURAL DEFECTS

These are all directly associated with the embankment and spillway and can be associated with foundation, materials used, design and construction techniques.

### 10.2.1 Slumping and sliding of the downstream face

Occasionally this may apply to the upstream side of the dam. It is usually the result of poor quality material, too steep side slopes, inadequate drainage and/or excessive seepage. If severe, the dam's stability can be affected and it is then very important to lower the reservoir water level as soon as possible.

Use of good material and well designed side slopes at the time of construction and following correct construction procedures will prevent these problems developing.

However, when serious problems do develop, especially in an old dam, major reconstruction work is the only solution and should include drainage relief measures in and underneath the downstream section, clay blankets upstream, the

flattening of side slopes and reduction in reservoir water levels. The latter can be maintained by lowering the spillway or drop inlet levels.

Other factors, such as low strength soils, poor compaction and compressible foundations, also contribute to partial slope failures and can be very difficult to remedy.

### 10.2.2 Foundation slope movements

Movement of the embankment on its foundation can lead to complete failure of the dam. Usually associated with a poor choice of site and, with larger dams, movement of the embankment will lead to cracks appearing in the structure. They are most serious when they extend transversely across the embankment and below the water line. Reduce the water level immediately and fill all cracks with good material and plant to grass.

Earth dams can absorb some movement without suffering damage but if cracks continue to form, or suddenly appear in old dams, it is best to seek expert advice immediately.

### 10.2.3 Piping

This occurs when seepage establishes a tunnel or pipe through an embankment and in severe cases can lead to undermining and the eventual collapse of the dam. It is most serious in dams constructed of poorer soils with greater permeabilities.

To avoid this it is best to anticipate such problems at the design stage and construct drains beneath the downstream section before the dam proper is started. However, when piping is excessive, or not allowed for, measures already outlined to reduce seepage should be followed.

When brown, muddy water is seen to emerge from the downstream face of the dam or seepage starts to increase, this can mean serious internal damage is occurring. This may be associated with the development of whirlpools on the upstream side when most severe. Always reduce the water level and carry out repair and remedial works without delay.

### 10.2.4 Breaching

A dam breaches when a section of the embankment finally gives way and a hole appears that can cause complete failure. Unless caused by overtopping by an exceptional flood (or too small a spillway), breaching is usually the result of one of the problems outlined above developing into a major fault. Always investigate the cause of the breach before commencing permanent repair work and, once the problem has been solved, the breach can be filled and the dam restored to its design condition. However, to fill the breach, certain guidelines must be followed – referring to **Figure 14**, the following must be adhered to:

- Always carry out repair work in the dry season and ensure there is enough time to complete the repair before the rains start.
- Remove all loose and poor material from the sides and the floor of the breach and ensure excavation is carried to good foundation (i.e. subsoil, rock, firm well compacted embankment or core material).
- Cut back the sides of the breach to a relatively flat slope (1:3 minimum and 1:5 or less where possible). This ensures plant and machinery can pass up and down the cut slope (to back-fill and compact) rather than through the breach area and that, when the gap is plugged, the repaired area is securely founded on the old dam material.

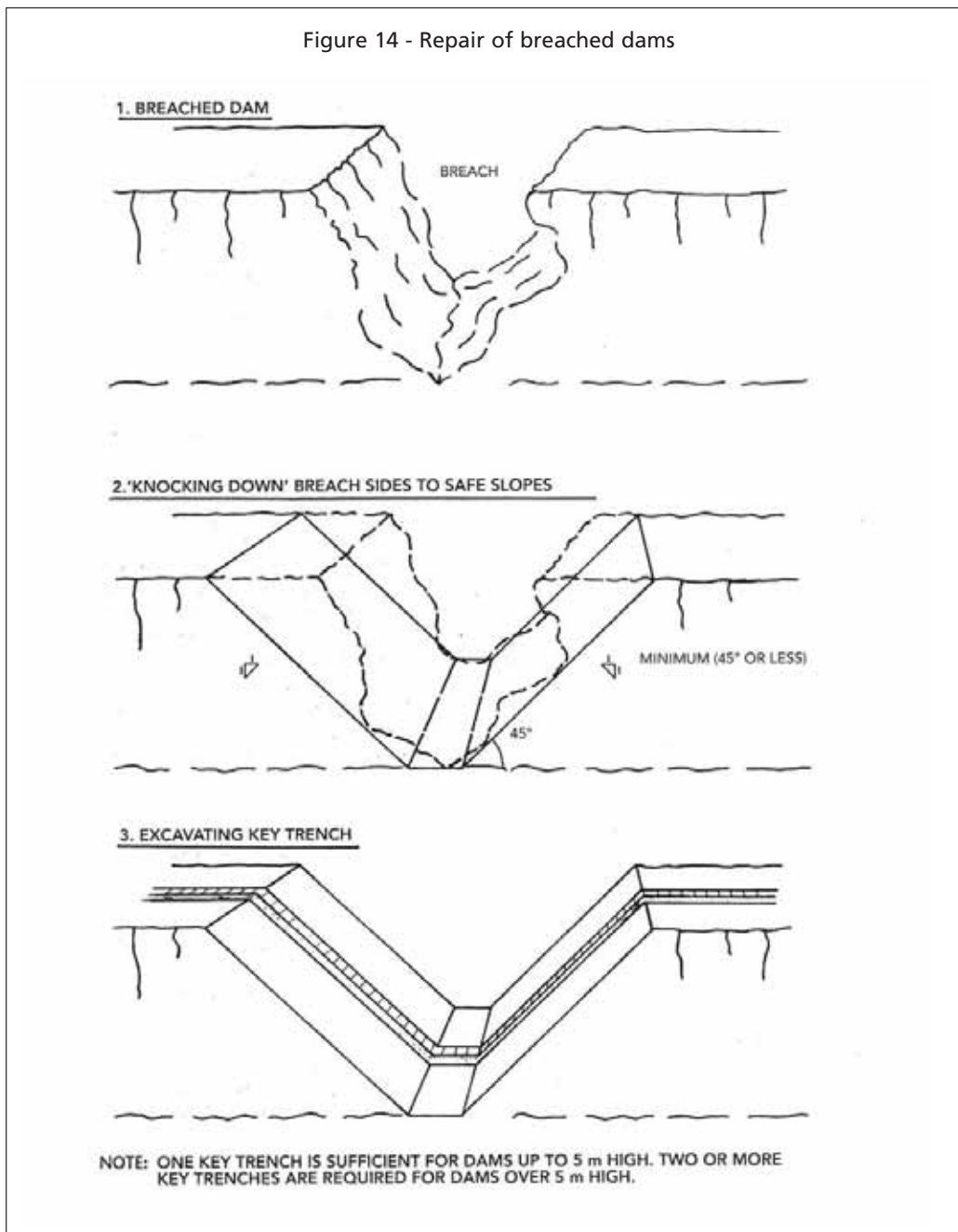

- Excavate key trenches as required.
- Reconstruct the embankment (refer to Section 7) to the new design requirements ensuring all backfill is installed in layers and is well compacted.
- Check and inspect the repair frequently immediately after reconstruction and pay special attention to the area subsequently.

It is very important to ensure a good bond between the old and the new material. If the sides are not cut back, and the key trenches not excavated, the repair area can

easily fail again. When the repair is done properly the area is better able to resist the pressure of water behind it and a slip surface between the old dam material, and the new is less likely to develop. A little extra care and attention at the time of repair is always preferable to a rushed, more general infilling of the breach.

A drawing illustrating a typical breach repair is provided in Annex 4.

Whenever a dam has suffered from a major problem like this, always ensure that the water level is not allowed to rise and fall rapidly. It should be kept below the maximum for a few years to assess the effectiveness of the repair and to enable the repaired section to settle. This section should be given special emphasis at times of inspection and monitoring.

#### **10.2.5 An eroded spillway**

Spillway erosion and the inability to carry flood flows are the main reasons behind many earth dam failures. Once erosion on a grassed spillway or a friable rock spillway has started, it is very difficult to prevent it recurring without continual maintenance and remedial procedures. Normally this signifies that solid rock should have been used for spilling flood water.

If a trickle flow has not been constructed, a lined channel in the spillway should be excavated and, to reduce risks, another second spillway may be built on the other end of the dam wall. Careful placement of sand bags or stop logs can then allow the alternating use of spillways to enable the maintenance of one or the other to be initiated. Stone pitching and concreting of the spillways and embankment are expensive solutions, which may have only partial success, if concrete is laid on earth it can easily be undermined and eroded. Simpler measures, such as increasing the available spillway width; the construction of a concrete sill at the spillway entrance (to prevent erosion in a sensitive area and dissipate some energy); the generous grassing of the spillway bed and protection (stone pitching, loose rock or gabions) of the sides including the outlet into the river or stream where the gullying will usually start; as well as continual inspection and maintenance in the flood season, will always minimize risks.

Where flood flows far exceed spillway capacity, the backing up of water in the reservoir can attain a level where it overtops the embankment. The correct assessment of anticipated flood flows and the maximizing of safety factors such as spillway width and freeboard, especially where hydrological information is insufficient, are absolutely vital. A spillway that is too wide is not a problem but one that is too narrow can, at worst, result in the loss of the dam and, at best, in further expenditure that could easily have been avoided.

#### **10.2.6 Wave action**

Wave action on the upstream face can cause erosion, which can increase the slope angle to an undesirable steepness or establish 'beaches' on the slope that could lead to the slumping of this section. If this is allowed to continue, it can reduce the crest level to below the full supply level. This is often exacerbated by poor grass growth and erosion from animal tracks and, as a result, it may become necessary to reconstruct the entire upstream area to reduce slopes and allow for the laying of rip-rap in the most susceptible areas. For large dams with high fluctuations in water level, the works involved can become quite expensive.



### 10.3 NON-STRUCTURAL DEFECTS

A dam that does not fill with water has failed just as much as one that suffers from the problems of embankment and spillway failures. Basically, non-structural defects result in the dam not meeting its design capabilities and usually this leads to a reduction in available water storage. Two main reasons can be identified:

#### 10.3.1 Dam reservoir fails to fill up

The dam may be too large for the catchment. This problem can be prevented at the design stage<sup>17</sup> by correctly assessing the catchment yield (i.e. average runoff per hectare or square kilometre in a 1 in 10 year (or as the designer/dam owner requires) rainy season including taking other dams and water uses into consideration). Reservoir inflow can be increased by constructing storm and contour drains to enhance runoff and channel water from the surrounding catchment if considered economic.

Where the yield is known to be satisfactory, it may be that the water is by passing the dam to such an extent that the reservoir cannot fill up. Often, as water pressure builds up, permeable material beneath the core or faults extending into the reservoir, can act as seepage drains. Water may re-appear downstream or contribute to groundwater recharge making identification and rectification of the problem difficult.

The careful monitoring of excavation at the time of construction of the cutoff trench to ensure it is dug deep enough, and that no permeable layers are likely to be beneath it (i.e. old stream beds or slate/schist type bedrock), will minimize the risk of such problems arising. The investigation of the river bed upstream of the dam at the feasibility study stage to locate swallow holes will also help. In order to ensure that borrow areas in the reservoir maintain water tightness under pressure, they should not be completely excavated of clay material.

Where leaks are suspected, the possible source area can be sealed by puddling clay in the reservoir immediately upstream of the embankment (especially where the water is deepest) and/or excavating a new cutoff trench to an impervious layer beneath core level, in the upstream section of the embankment. The latter may prove most economic if a large reservoir area has to be layered with impermeable material.

#### 10.3.2 Dam silts up

This is usually a long-term problem that can be avoided if dams are not constructed on rivers that carry heavy sediment loads. If undetected at the feasibility study stage, certain remedial measures can be taken:

- The local catchment land practices can be improved by better crop rotation, reduced stocking rates and by introducing conservation methods.
- The vegetation cover in the catchment can be maximized, especially in dry season type climates where early rains lead to high erosion levels. Deforestation should be minimized throughout the catchment and the practice of establishing gardens for fruit and vegetables close to the reservoir or river (to facilitate hand irrigation), common in many locations, should be discouraged.
- Where the latter does occur, improved cultivation practices such as contour ridging and ploughing, maintaining a band of uncultivated land close to the

---

<sup>17</sup> Refer to section 5.5.

- river and reservoir and conserving waterways can reduce runoff and erosion.
- Gullies and other high runoff areas must be reclaimed or at least stabilized.
  - Silt traps upstream of the main dam can be constructed. Small dams or sumps collect a major proportion of the silt before it reaches the reservoir. These are usually temporary, often expensive and require regular de-silting and therefore should be regarded as stop-gap measures while methods to reduce the silt at source are initiated.

Where a reservoir is severely silted, it is not normally economic to excavate the reservoir. Moving and safely dumping huge quantities of wet silt can prove difficult. The preferable alternative is to raise the dam once the sediment inflow has been reduced by the measures above. This will increase the storage capacity at the expense of a relatively small increase in earthworks' volume.

For dams being constructed on rivers with high levels of silt, the construction of an embankment with a wide crest will facilitate the raising of the dam in subsequent years.

## Bibliography and further references

**British Standard 1377**, London, UK, 1990 nine standards: references 1377-1-1990 to 1377-9-1990 inclusive and including later amendments at [www.bsigroup.com](http://www.bsigroup.com).

**Food and Agriculture Organization**. 2001. Small dams and weirs in earth and gabion materials, AGL/MISC/32/2001. FAO Land and Water Development Division, Rome.

**Food and Agriculture Organization**. 2006. Simple methods for aquaculture – Manuals from the FAO training series, CD-Rom set. FAO Inland Water Resources and Aquaculture Service.

**Hudson, N.W.** 1975. Field engineering for agricultural development. Oxford, UK, Clarendon Press.

**Ministry of Agriculture and Cooperatives of Swaziland**. 1990. Repair and maintenance of small earth dams. Field Support Guide 109, Swaziland.

**Ministry of Agriculture and Cooperatives of Swaziland**. 1992. Handbook on dam design and construction.

**Nelson, K.** 1997. Design and construction of small earth dams. Australia, Inkata Press. Third edition.

**Schwab, G.O., Fangmeier, D.D., Elliot, W.J.T. and Frevert, R.K.** 1981. Soil and Water Conservation Engineering. New York, John Wiley & Sons. Third edition.

**Sherard, J.L., Woodward, R.J. and Gizienski, S.F.** 1964. Earth and rock dams. New York, John Wiley & Sons.

**Stephens, T.** 1991. Handbook on small earth dams and weirs – A guide to siting, design and construction. Bedfordshire, UK, Cranfield Press.

**Terzaghi, K. and Peck, R.B.** 1967. Soil mechanics in engineering practice. New York, John Wiley & Sons. Second Edition.

**United States Bureau of Reclamation (USBR)**. 2006. Design of small dams. Water Resources Technical Publication Series. Washington, DC.

**World Bank, Food and Agriculture Organization of the United Nations, International Fund for Agricultural Development**. 2009. Gender in agriculture sourcebook. Washington, DC.

## Glossary

Atterberg limits	They are a basic measure of the nature of a fine-grained soil. Depending on the water content of the soil, the soil may appear in four states: solid, semi-solid, plastic and liquid. In each state the consistency and behaviour of a soil is different and so are its engineering properties.
Backfilling	The on-site filling of a trench or other excavation with either material originally excavated from the same excavation or using material imported from elsewhere.
Berm	A horizontal bench or terrace-like area on an embankment slope, included for stability or where a change of gradient is required.
Borrow pit	A source for earthworks' materials for embankment construction. Best located within the reservoir area to improve storage and avoid the need for restoration measures after the dam has been completed.
Breaching	Complete removal of a section of the dam by the reservoir water breaking through the embankment. Can be induced by erosion, foundation movement or overtopping.
Catchment area	This is the area upstream of the dam that takes in all the streams and rivers that supply the dam.
Catchment yield	The estimated total runoff from a catchment area for a certain period; usually one year.
Compaction	The compression, by mechanical means of a soil material, in embankment construction, to improve its stability and load-bearing characteristics.
Core	The central section of a zoned dam, constructed of highly impermeable material to seal the embankment from seepage. The below ground section of the core is referred to as the cutoff.
Crest	This is the top of the embankment. The spillway crest is the level at which water will begin to flow in the spillway.

Crumb test	Is a simple, quick method for identification of a dispersive clay soil.
Cutoff	This is the area excavated, below ground under the core and through any permeable material to reach a more impermeable stratum, and to be backfilled (and compacted) with highly impermeable material to seal the foundation against seepage.
Desilting	The excavation of silt or other material from a dam reservoir to improve storage capacity. It may be more economic to raise the height of the embankment to achieve an increase in storage than to desilt a large basin area.
Earthworks	All the soil material to be used in the construction of a dam will comprise the earthworks.
Embankment	This is the dam wall.
Erosion	The removal of soil and rock by natural agencies such as rainfall, river flows, seepage or slumping. Often accelerated by people or animals by overgrazing or by the formation of paths and tracks.
Fetch	The maximum unobstructed distance, at full supply level, that the wind can travel across a reservoir to raise waves that will impact on the embankment.
Filling	The embankment construction. This is usually done on a layer-by-layer basis accompanied by moistening and compaction.
Flood flows	Above normal river flows following excessive rainfall.
Freeboard	The difference in height between the crest of the dam and the level of the spillway entrance.
Full supply level	The maximum water level the dam is designed for. For small dams this is the same as the spillway entrance level.
Gabions	A patented mean for erosion protection in the form of wire baskets or mattresses selectively filled <i>in situ</i> with rock.
Geotextile	A synthetic permeable fabric of varying thickness with filtering and drainage properties. When placed behind and beneath gabions, they limit the movement of soil material in suspension from the natural ground into the gabion basket or mattress.

Homogenous dam	An embankment constructed with one consistently similar soil material to produce an homogenous structure.
Modified homogenous dam	An embankment similar to an homogenous dam but with a filter zone in the downstream side to safely draw down the phreatic surface and then pass the drainage/seepage water out of the embankment.
Moisture conditioning	The wetting (but not waterlogging) or drying of a soil to assist compaction.
Outfall	The area at the end of the spillway where it discharges to a stream or similar. Erosion often starts here if the outfall has not been properly designed, protected or maintained.
Overtopping	This is where excessive flood flows pass over the embankment because of insufficient spillway capacity. Erosion always follows and, if severe, can lead to major damage.
Probable maximum flood	The peak flood from a catchment based (for the design of the dam and spillway) on a return period of 1 in X years.
Perennial flow	A stream that flows all year round is said to be perennial. The alternative, where a stream dries up periodically is said to be seasonal.
Permeability	Is a measure of the ability of a porous material (often, a rock or less consolidated material such as soil) to transmit fluids.
Phreatic surface	The top water level in any saturated zone of the embankment.
Piezometer	A small diameter observation well in the embankment equipped with a measuring device, to record water levels and in particular notify engineers of variations.
Piping	Piping occurs when hydraulic flows (seepage) through the embankment carry soil material in suspension causing pipes to develop in the structure and lead to internal erosion.
Planimeter	An instrument to measure area from a plan or map.
Proctor Test	A standard test, developed in the United States, for moisture and compaction control for cohesive soils.

Puddling	The use of clay to seal a surface by mixing the soil with water and layering it on a surface and then compacting it by machine or hand (historically by cattle trampling) to make it watertight.
Seepage	Water moving through or under an embankment is referred to as seepage. All dams will, to some extent, seep and, if small or controlled, such seepage is not considered a serious problem.
Settlement	The embankment, however well built, will settle to some extent. Provision for this should be included at the time of construction (settlement allowance) by raising the midpoint of the embankment and tapering this raised area off to the valley sides.
Shear strength	The resistance to deformation in soil by cohesion, usually increased by compaction at a certain moisture content.
Slumping	The movement of earth through erosion or water-logging (especially on steep slopes) away from either face of the embankment. May also be referred to as slippage or sloughing.
Slush grouting	The filling in, with a plaster-like mortar, of cracks and fissures on a rocky surface in preparation for concrete work or backfilling.
Spillway	The overflow section of the dam, dependent not on the size of the dam but on the size of the catchment and its hydrological and other characteristics. It must be constructed to dimensions to safely carry away the design probable maximum flood (PMF) when the dam is full.
Stone pitching	The protection of a vulnerable surface by the placement of similar sized stones sometime bedded in a mortar. Often used for toe drains.
Storage potential	The maximum possible volume of water the dam can store when the reservoir is full.
Time of concentration	The time between a storm commencing on a catchment and the development of the maximum flood at the dam. Used in spillway design.
Turbulence	Rapid, irregular, highly erosive flow. To be avoided on grass or earth spillways by flat slopes and wide, shallow channels.
Training wall	The extension of the embankment, constructed to safely contain spillway flows and to prevent water

---

	affecting the downstream area of the dam. May also be referred to as the training bank.
Waterline	The level of water in the reservoir is referred to as the waterline or water level. The maximum water level possible is referred to as the full supply level (FSL).
Waterlogging	A soil completely saturated is waterlogged. The downstream section of the embankment can become unstable (especially as it usually designed with steeper slopes and more permeable materials) if allowed to become waterlogged. Free drainage is therefore important in this area of the embankment.
Zoned dam	An embankment, when constructed of varying soil materials, differentiated according to position and role in the structure, is said to be zoned.



# Annex 1

## Procurement guidelines for tender preparation, evaluation and award of contract

### INTRODUCTION

All procurement (and planning) must conform to the three pillars of Integrity, Transparency and Accountability. These apply to all activities before construction, the actual construction (especially if consultants and contractors are to be used) and to the subsequent operation and maintenance of the structure and any related infrastructure such as an irrigation scheme.

Procurement rules exist in most countries and for all international financing agencies and these must be followed. These rules should encourage true and open competition in tendering and contract award, open meetings and equitable and fair distribution of information, effective monitoring and auditing of all processes and implementation activities.

As part of the preparation work, and before any tender is advertised, the procuring agency requires a realistic estimate (based on a good quality design and costing process) of the cost of the structure with a breakdown of significant cost items. To prepare such an estimate, an engineer (**The Engineer**) should be selected and be appointed to not only carry out this preliminary work but continue to supervise the contractor and ensure all works are carried out according to the design and to the highest quality possible.

This estimate must be kept strictly confidential and there should be no links between personnel having this knowledge and the bidders. Should the subsequent bidding result in bids received that vary greatly from this estimate, questions should be raised on the validity of the bids. Underestimates from bidders could lead to poor contract performance and the need for changes and variations as the contract proceeds and overestimates may suggest over pricing, cartel links or other unrealistic bidding.

Decision-making criteria at all stages must be clear, justifiable and objective (with a written record where needed) with no room for discretion at any time, especially in the evaluation and comparison of the bids.

Prequalification of bidders for significantly expensive contracts or a series of small contracts<sup>18</sup> is recommended, but avoiding the possibility of establishing cartels. This prequalification should be based on professional competence (staff and equipment), relevant experience, financial capability and integrity. Any contractor or consultant that has recent, relevant convictions or has been disbarred for irregu-

<sup>18</sup> Awarding contracts for a number of small dams in one area, or for one project as one overall contract, may result in economies of scale in mobilization, the use of plant and equipment and in supervision.

lar, financial activities, or failure to complete contracts, should not be allowed to prequalify.

### **PREPARATION WORK**

The preparation of tender and contract documents, including all survey and design work needed to prepare quantities and guideline costings, should take place in good time. If funds are to be sourced from international lending agencies or donors, their guidelines will have to be followed and examples of advertisements and documents from such organizations should be obtained at the beginning of this process.

Preparation may require the application for land and water rights, environmental impact assessments plus any needed compensation or resettlement plans. These must be completed before the dam construction can be approved and allowed to proceed.

In many places, construction can only take place in the dry season when river levels are low, access to the site easier and moisture control for compaction possible. Thus, the design and tender process should take place in the rainy season and be timed to be completed by the beginning of the next dry season in time for mobilization of plant and equipment as the ground begins to dry out. Clearing access roads, felling and removing trees and stripping foundation areas is often best begun before the ground has completely dried out. The end of one rainy season and the start of the subsequent dry season are the best times for this.

### **ADVERTISEMENT OF THE TENDER**

Always include a site visit in any tender advertisement and award procedure.

The tender advertisement period has to take into account the need for approval (usually at the advertisement and award stages) from the lender or donor, the need to adhere to local or national government regulations and bureaucratic procedures, whether it will be advertised internationally, regionally or nationally and the scope of works. A tender for one small dam could be advertised nationally and potential tenderers given 6 to 8 weeks to respond, including site visits and collection of documents. Thus, the tender period for this, including advertisement and evaluation could be around 12 weeks.

A series of dams being funded by one or more donors may require international advertisement with time for potential bidders to collect documents, make site visits and prepare timetables and bids (in their home countries). Such a tender may require up to 20 weeks to complete with further time required for the winning bidder to mobilize.

The more complicated the works and the size and number of dams to be built, the longer the tender process will take. Guidelines to assist in the preparation of tender and contract documents, and in the award of a contract for a simple project involving only one or two small dams, are given below:

The evaluation modalities (see details hereafter) – or any modified equivalents – are to be attached to every tender document to permit bidders to understand the proposed evaluation process.

Always keep written records of significant events and always advise bidders in writing of any matter that could have legal implications. Any specific information given to any tenderer that is not in the documents should be passed on, in writing, to all other tenderers.

## **THE EVALUATION MODALITIES**

Two options exist for tender, and the choice has to be indicated in the tender document.

In the first option, the technical and financial offer are combined and presented in a single envelope. The second option, called staged tender, involves a two envelope system in which the technical proposal (first envelope) is evaluated and bids ranked before the financial offer (second envelope) is opened. It ensures that price does not influence the technical evaluation of the bid. This approach should be preferred, in particular in the case of complex contracts. Where a two envelope tendering process is used, it should be indicated in the tender document that tenderers are to place the technical and financial components of their tenders in separate, clearly marked, envelopes. These envelopes are to be placed inside a single envelope and normal procedures apply for the lodging of the tender.

A points system should be adopted, based on criteria that can be adjusted according to country, individual dam sites, scope of work and other factors. All tenderers must be made aware of the evaluation procedure to be followed and whether there are any special conditions involved. The following point system can be used as a guide:

### **Technical bid: 50 points**

#### **Experience – 20 Points maximum**

This is calculated according to the personal evaluation of each team member and considers the following: any experience (good or bad) with the contractor, experience of the contractor in the area and in similar works.

#### **Equipment and Staff – 10 Points maximum**

Again individual team member evaluation is used. Factors such as numbers and age of equipment, suitability of equipment for the works involved, experience of staff (including operators and supervisors) and support the contractor has in country (including provision of fuel supplies, site accommodation, mechanical backup and so on) should be considered. Where labour intensive works are being promoted this category could be given more points (20 perhaps and the experience category reduced to 10) and those contractors offering to follow such procedures given the highest number of points.

#### **Work Programme – 10 Points maximum**

Highest points are given to contractors who can complete the works within the already decided project time frame or before the next rainy season begins.

#### **Location of Contractor – 10 Points maximum**

Based on mobilization distance rather than physical location of the contractor, this is also determined at the judgment of each team member. As a guide, highest (i.e. 10) points should be given to contractors located within the local area, then say 8 points for provincial locations, 4 points for nationally based contractors and 2 or less for contractors mobilizing from outside the country.

**Financial bid: 50 points****Cost - 50 Points maximum**

The lowest priced bid receives 50 points and other bids receive points based on 50 minus 1 point for every 2 percent difference from the lowest bid price. Any bids more than 100 percent higher than the lowest bid receive no points.

**The evaluation**

An evaluation team of at least three people should be established. At least one person should have an engineering background (The Engineer is best selected for this) and be able to advise other team members on technical issues if they arise. Inclusion of a local (dam committee) person may also prove useful. A team of more than six may, however, be too cumbersome and thus inappropriate.

Team members should avoid fraternization and other close contact with bidders at this time.

The following steps are to be followed:

**Step 1: RECEPTION OF THE BIDS**

Following advertisement of the tender, ensure that every tenderer who pays the required, non-refundable, fee<sup>19</sup> receives the documents, design drawings, quantities (but no guideline costs), any Community Agreement, the date of the site visit and details on where the tender documents are to be delivered, the deadline for delivery and the location and time of tender opening.

If the deadline is changed, all potential tenderers must be advised either personally (if few in number) or by advertisement in the media.

Bids received should be noted in a diary and the bidder and staff member sign to confirm date and time received. Any bids delivered in unsealed envelopes should be rejected and the bidder advised in writing that his/her fee is forfeited and that s/he cannot re-bid. All other bids are to be kept in a secure and inaccessible location until the time of tender opening.

The site visit should be formally recorded in the same diary and any bidder unable to make the visit should be excluded from the process and his/her bid returned unopened.

**Step 2: OPENING OF THE BIDS**

The responsible officer opening the bids should first advise all those present of the procedure he/she will follow. Brief details on the evaluation process (already provided in the documents and based on the guidelines above should be given to assure potential bidders that the evaluation is to be fair and equitable.

At tender opening, one staff member should be given the responsibility for opening the bids received. A secretary will be required to note persons attending and any comments (especially objections) made. The minutes – brief and noting points only – should be filed for future reference.

<sup>19</sup> Accept cash or bank certified cheques only.

### Step 3: REVIEW OF THE DOCUMENTATION

As each bid is opened, the responsible staff member may name the bidder but then must check that the bid is complete and conforms to the advertised conditions. If for any reason it is not complete (for example the site visit certificate is missing), the bid should be rejected and the bid price not disclosed. The whole document has to be returned to the bidder with a covering letter stating why it had been rejected. There is no appeal on this matter.

Minor omissions or errors can be accepted. Small arithmetic errors should be corrected and the revised figure used in the evaluation. If significantly large errors that may affect the bid price are noted, and at the discretion of the evaluation team, the bid should be rejected.

Unrealistic bids with either costs shown at levels impossible to achieve or for bidders who show that they are completely inexperienced or have completely inappropriate equipment, can also be rejected at this stage.

If the bidders have not been prequalified some investigation at this stage (this process should be noted in the bidding documents and/or tender advertisement) into the integrity of the bidder should be carried out. Any bidder with recent<sup>20</sup> criminal convictions relating to fraud, bribery or corruption or with serious, proved cases of contract malpractice or failure, should be excluded at this time. The bid should not be evaluated. As above, the bid should be returned to the bidder with a covering letter and all other bidders informed of the decision.

### Step 4: TECHNICAL EVALUATION

Once the bids are declared valid, the actual points evaluation procedure can begin.

Tenders should initially be assessed, in accordance with the evaluation methodology being utilized, against non-price criteria, that is, on their technical merits. The evaluation team should not have access to the tender price at this stage. The assessment of the non-price criteria is to be documented before moving onto the next stage of the evaluation.

### Step 5: FINANCIAL ASSESSMENT

Once tenders have been assessed against the technical criteria, a financial evaluation of the prices tendered (or quoted) can then be undertaken. The results of the financial assessment are to be documented before moving onto the next stage of the evaluation.

### Step 6: ASSESSMENT OF 'BEST COMBINED OFFER'

Having separately assessed tenders against technical and financial criteria, a comparison of 'technical worth' and 'price', is undertaken in accordance with the criteria established in the tender document, to determine which tender represents the best combined offer. This stage will establish the final ranking of the tenders.

<sup>20</sup> In the last five years or any other agreed period.

## AWARDING THE CONTRACT

Once the final ranking has been established, the contractor with the highest total should be awarded the contract.

If, for exceptional reasons, a decision is made that does not award the contract to the highest evaluated bidder, other bidders must be formally advised of the reasons why and given a period (10-14 days) in which to object but not change their bids. All objections then have to be looked at and a final decision made. Because this can lead to delays and legal issues it is best not to make decisions that award contracts to bidders other than the highest evaluated.

Lastly, once a decision has been made to award the contract, the potential contractor can be contacted and the contract awarded. It is recommended that the winning bidder should not be negotiated with to either reduce the price (i.e. if above the budget for the dam or project or if all bids are considered unacceptably high in part or whole) or to improve on the bid to include items considered deficient. It is not unethical to do so as long as it is done for the interest of the cost effectiveness and in a open and transparent way.

If the award of contract fails, or is stopped for any reason, the second highest bidder can be brought in. Do not however negotiate with two bidders at any one time in an attempt to play off one against the other. This is extremely unethical and unprofessional.

Once the contract has been awarded, the other, unsuccessful bidders should be formally advised of the award but not of the final price. The actual evaluation is confidential and information therein is only released if a losing bidder should complain and arbitration has to take place. The award decision should be published with a list of all the bidders, major elements of the evaluation process detailed and specific reasons why the award has been made to the winning contractor.

A sample evaluation sheet is provided below (refer to **Table A1**).

**Table A1 – Sample evaluation points table**

Table A1 – Sample evaluation points table							
Project .....							
Name of dam/spillway .....							
Date .....							
	Bid price	Price (50 max)	Experience (20 max)	Staff/equipment (10 max)	Work programme (10 max)	Location (10 max)	Total points (100 max)
Names of bidders	Lowest	50	Calculate	Calculate	Calculate	Calculate	Add from calculations
	Next lowest and so on	Calculate	“ ”	“ ”	“ ”	“ ”	in columns to the left
		“ ”	“ ”	“ ”	“ ”	“ ”	

## CONTRACT SUPERVISION

Continuous monitoring and auditing is required to supervise any contract. This can be carried out by the dam owner, government agencies or consultants appointed to supervise a contract being funded by an international financing agency. For all but the former, the supervisor must in turn be monitored and audited to ensure compliance with the contract and to encourage cost effectiveness and to avoid corruption. The World Bank establishes a panel of experts for every large dam contract and

these personnel are fully independent and are able to carry out regular (and irregular) monitoring and auditing activities throughout the duration of the contract.

Particular attention should be paid to contract variations. Any variation should be scrutinized both individually and in aggregate, and once a financial ceiling is reached (based on the contract price and usually in the range of 10-15 percent) the independent outside experts should be called in. Any proven case of variation in response to bribery and corruption should cause the immediate cancellation of the contract (without any penalty payment to the contractor) and dismissal and prosecution of any supervision personnel involved.

For all contracts, an effective dispute resolution organization/entity is required. As with the panel of experts, this should be independent and suitably qualified to resolve disputes impartially and in the interest of fairness and integrity. This may be a government agency or could be based in the private sector. Details of such an agency should be clearly stated in all tender and contract documents.

## **PAYMENTS**

The sequence of payments to the contractor will have been outlined in the tender and contract documents. Usually these will have been negotiated at contract signing and any variations allowed outlined in the tender documents.

### Advance payment:

Most dam contracts will require an advance payment being made to the contractor for **mobilization** (establishing a site complete with offices, power, communications and water supplies, clearing the dam site, establishing stockpiles of materials, moving equipment and staff to site and related initial activities). This would be recorded as an advance payment and can comprise between 10 and 25 percent of the total contract amount. It can either be made as a lump sum payment or can be proportionally recovered as routine payments are made to the contractor as the works proceed.

### Routine progress payments:

Routine payments can be agreed at contract signing and can take the form of a monthly payment based on estimated amounts of work completed or can be based on proportion of the dam being completed. Either way, the payment requests have to be submitted by the contractor and then checked and approved by the Engineer supervising the works.

All approved payments should be scrutinized and cleared; then paid quickly. Many contractors do not have the financial resources to cater for lengthy delays in routine payments and, where private sector contractors are working for public sector clients such as government ministries, effective and transparent ways and means of ensuring quick payments to the contractors should be established before the project starts.

### Variation payments:

In all but the simplest contracts, a sum for unexpected works or for variations to the design should be catered for. Usually listed in the Bill of Quantities as **Contingencies**, this can be calculated at around 5 to 15 percent of the total contract sum.

Again all such payments should be initially approved by the engineer, scrutinized once the works have been done and then paid quickly to the contractor. Note the comment above on this.

Final payments:

At the end of construction, the works should be inspected and signed off by the engineer. The contractor can then demobilize and leave the site. Usually, the final payment is withheld for a period agreed in the contract – one year is satisfactory and will give the dam a chance to fill and be used before the contractor's liability is removed. During this period, the dam should be closely monitored and checked. Defects should be noted and rectified at his/her expense.

If the contractor is unable or unwilling to do this work, the retained sum can be used to pay another contractor to do the work required.

Once the liability period is over, the engineer certifies the dam as good, and the contractor can be paid the balance owed.

## **FINAL INSPECTION AND MEASUREMENT**

This is an important activity and can be carried out by the engineer to ensure the completed dam has been built to the design and to the highest standard possible. This activity can be carried out jointly by the engineer and the contractor to ensure there are no disputed findings but the engineer is the overall responsible officer.

The final inspection is best completed before the contractor demobilizes to ensure that any outstanding work noted can be completed without delay. As built drawings should be produced and kept on record.

The maintenance and safety programme can then be instigated.



## Annex 2

# Cost Benefit Analysis

The example below is from a project for an 11 m high dam and associated private irrigation scheme costed for Zambia in 2008.

Table A2: Cost Summary Table

Bill	Activity	Unit Rate	Quantity	Cost US\$	Amount US\$
1	Site investigation work	Sum	–	–	12 000.00
2	Engineer's Fees: design and supervision	Sum	–	–	17 000.00
3	Mobilization	Sum	–	–	7 500.00
4	Clearing site:				
	Embankment area	ha	5	2 000	10 000.00
	Reservoir	ha	40	500	20 000.00
5	Cut-off/Core:				
	Excavation	m <sup>3</sup>	750	5.5	4 125.00
	Backfilling	m <sup>3</sup>	750	7.0	5 250.00
6	Embankment	m <sup>3</sup>	22 000	3.5	77 000.00
7	Training banks	m <sup>3</sup>	1 400	6.0	8 400.00
8	Spillway	m <sup>3</sup>	770	6.0	4 620.00
9	Finishing works	hours	240	10	2 400.00
10	Other dam work including settlement works after construction	Sum	–	–	5 000.00
<b>Subtotal Dam</b>				<b>A</b>	<b>173 295.00</b>
11	Irrigation scheme (one centre-pivot)	ha	35		42 000.00
12	Miscellaneous (access road/power line)	Sum	–		30 000.00
<b>Subtotal Irrigation Scheme</b>				<b>B</b>	<b>72 000.00</b>
Subtotal Overall Project				A+B	245 295.00
Contingencies				10%	24 560.00
<b>Grand total</b>				<b>US\$</b>	<b>269 845.00</b>

First prepare the cost table as shown in **Table A2, Section 6.6**.

### INITIAL ANALYSIS<sup>21</sup>:

The total estimated cost of the bulk water infrastructure (dam, irrigation scheme, associated infrastructure such as provision of access roads and power lines and the supervision by a qualified engineer is US\$ 270 000 for a end result of 35 ha irrigated. Thus, the per ha cost for the scheme in capital funding is US\$7 715 about the median range for irrigation development in Zambia in 2008.

<sup>21</sup> The FAO *Rural Invest* toolkit provides an accurate and transparent methodology for formulating, costing and evaluating small-to medium-scale investments using custom developed software. Both income generating and non-income generating can be considered. Further information can be found at [www.fao.org/tc/tci/ruralinvest\\_en.asp](http://www.fao.org/tc/tci/ruralinvest_en.asp)

Table A3: Proposed time schedule for the works

Bill	Activity	April	May	June	July	Aug	Sep	Oct	Nov
1	Site investigation	■							
2	Engineer: design supervision		■	■	■	■	■	■	■
3	Mobilization			■	■	■	■	■	■
4	Clearing site			■	■	■	■	■	■
5	Cutoff/Core			■	■	■	■	■	■
6	Embankment					■	■	■	■
7	Training banks					■	■	■	■
8	Spillway						■	■	■
9	Finishing							■	■
10	Other							■	■
11	Irrigation scheme					■	■	■	■
12	Roads/Power lines				■	■	■	■	■

**Notes:**

Schedule based on a dry season period April-November.

Site investigation could occur the year before.

The spillway must be in place and operational before the rainy season begins.

The irrigation scheme works could begin the following year while the dam is filling.

The irrigation scheme comprises two electric powered pumps, pipeline, fittings and a centre-pivot irrigator for a total of 35 ha. Reservoir area clearing is usually trees and large shrubs only. Topsoil can be stripped in areas that will be used as borrow pits.

The per hectare cost is a useful way of comparing dam sites where irrigation is involved and can be done for just the cost of the dam alone or for the combined costs of the dam and its attendant irrigation scheme.

Second comparisons can be made on the cost of the dam for the amount of water stored – in this case the capacity of the dam (which determined the area that could be irrigated – for wheat in the dry season) was estimated at 280 000 m<sup>3</sup>. Thus, the cost for the water stored was US\$1.47/m<sup>3</sup> taking into account the cost of the dam above plus a 10 percent contingency. Where more than one dam site exists this is a useful means of comparison for economic reasons.

**FURTHER ANALYSIS:**

For assessing economic viability the costs and benefits can be estimated (and again comparisons made between sites and schemes to evaluate the highest potential sites to be developed). In this example, wheat was the dry season crop to be grown on the 235 ha irrigation scheme. Zambia wheat prices in 2008 were US\$450/t and wheat yields from irrigation schemes in Zambia consistently average 6 t/ha. Thus, for 35 ha, yields would total 210 t and bring in a return of US\$94 500 per season based on 2008 prices. The rainy season crops were planned as a mix of maize and soya beans which would yield 8 t/ha for maize and 2 tons/ha for soya bean. Farm gate selling prices in 2008 were US\$220/t for maize and US\$300/t for soya beans.

Table A4: Return to Farming Activities (One Farming Year – April to April)

Crop	Yield (35 ha)	Area farmed	Farm gate price US\$	Production	Total received US\$
Wheat	6 t/ha	35 ha	450/t	210 t	94 500.00
Maize	8 t/ha	15 ha	220/t	120 t	26 400.00
Soya	2 t/ha	20 ha	300/t	40 t	12 000.00
Total					132 900.00

Thus, a rough estimate can be made of the return the irrigator will receive for one farming year for the 35 ha

Average input costs per farming year were US\$750/ha for fertilizer, other inputs including land preparation and harvesting and US\$300/ha for irrigation pumping costs (both dry season and supplemental). Thus, the overall input costs were US\$1 150/ha for 35 ha, totalling US\$40 250 for the farming year. It would seem therefore, without a comprehensive cost benefit analysis, that the construction of the dam and irrigation scheme are economic with annual 'profits' on the 35 ha exceeding US\$90 000, enough to contribute to operation and maintenance costs and to pay off the capital cost of the dam and scheme in 3-4 years.

## Annex 3

# Fish Production in Farm Dams

### DAMS AND FISH PRODUCTION

The majority of small earth dams are constructed for water conservation, irrigation and animal watering, domestic water supplies and other purposes. Dams are rarely constructed for fish farming but can be used for this purpose in conjunction with other uses.

If fish farming is considered at the design stage of the dam, benefits in production and yield can be achieved at little extra expense in the overall cost of the dam. Dams with a likelihood of significant through flow, or those with steep sides and depths greater than 3-5 m, cannot be considered as suitable for significant fish production.

### CONSTRUCTION CONSIDERATIONS

The site for the reservoir should be stripped as much as possible of vegetation to avoid a build up of carbon dioxide and methane in the water after first filling – this is also desirable to reduce the production of greenhouse gases<sup>22</sup> and minimize the effects of the decomposition of organic matter on oxygen levels in the water – when rotting vegetation in the water would provide a hostile environment for any fish. This removal of existing vegetation is advisable – especially in cooler areas where the breakdown of the plant material can take a long time – when regular flows are released from the dam (for example for hydroelectric power generation) as polluted water would then be introduced into the downstream watercourse.

In areas of highly acidic soils (as is common in central and southern Africa) liming the reservoir area with up to 2 t/ha (or the recommended rate for normal crop production) broadcast and then worked into the topsoil before first filling can be useful to reduce acidity and encourage more alkaline water (pH 7.0 to 8.5 is the ideal range) to be stored. Fish production is enhanced in alkaline waters but this would have to be considered carefully where the reservoir water was primarily for irrigation or domestic use where a neutral pH of 7.0 or lower is recommended.

Rocky areas within the confines of the reservoir can be left to provide shelter for fish and insects and for breeding purposes. If desirable one or two such areas can be built up to create islands in the full reservoir and these will encourage bird life as well as provide extra shallow areas for fish breeding and feeding. For larger dams, where netting may occur, rocky areas on the reservoir floor may have to be removed to prevent snagging and damage to nets.

In all cases the dams should not be stocked with fish until at least 3-4 months after first fillin. This will allow the water to ‘mature’ and develop a stable ecosystem that can support fish and other wildlife.

---

<sup>22</sup> It was estimated in 2000 that dam reservoirs contributed up to 7 percent of the world’s greenhouse gases.

## RESERVOIR SIZE AND DEPTH CONSIDERATIONS

### → Large dams with 10 ha or more of reservoir surface area:

Where such dams have significant through flows, or are mostly of depths greater than 5 m, the potential for fish production will be limited. Other factors, including turbidity, water temperature, variations in pH and low oxygen content waters may also affect production.

Generally areas of depth 3-5 m are ideal for fish production.

### → Medium dams with 3-10 ha reservoir surface area:

The constraints to through flow and depth above apply, but generally these dams are well-suited to fish production. Should significant areas of the reservoir provide for shallow water, it may be economic to consider liming the reservoir soil before filling and fertilizing the water, 14-21 days after liming has been completed,<sup>23</sup> to encourage plankton and algae growth and for supplementary feeding of the fish. Fertilizer can take the form of inorganic material (dissolved in water and applied at time of higher water temperatures) or manure. For the latter it is often advantageous to establish piggeries or similar near the dam and apply manure at a rate of up to 100 kg/ha a day – either initially worked into the soil on the dry reservoir bed or placed in small quantities at regular intervals in the shallow water.

Fertilizing/manuring of the water should be done at regular intervals in quantities that do not pollute the water. Fresh manure will be eaten by fish and any remaining portion will induce the growth of minute plant and animal organisms.

Fertilizing should not be done at times of high through flows or at times of low water levels. Care to maintain good vegetation control is also linked. Excessive growth of weeds will lead to lower fish populations, smaller fish, use nutrients that otherwise may produce plankton, interfere with swimming and boating and also encourage water-borne diseases such as malaria and bilharzias. It is important to balance vegetation growth in a dam reservoir so shelter is provided for smaller fish, insects and other small animals, the water is oxygenated and decaying plant life provides an important source of fertilizer without having excessive vegetation and the subsequent adverse affects on the water. Occasionally, manual clearing of weeds may be required to ensure plant growth is not too excessive.

### → Small dams less than 3 ha reservoir surface area:

These structures include seasonal dams and larger fish ponds and are the most effective sources of fish production, especially if they have extensive areas of water between 3 and 5 m deep.

The treatments suggested above including fertilizer or manure and liming combined with good management and supplementary feeding can achieve high yields of fish production. These dams are more suited to fish farming rather than fish stocking and should be managed accordingly.

<sup>23</sup> This is not acceptable for dams that provide domestic water supplies.

For developing fish farming in all dams, a good start is to refer to the Simple methods for aquaculture (FAO, 2006), which includes manuals for management and farming techniques for freshwater fish culture.

Annex 4

## Examples of standard drawings

DRAWING 1: DAM DRAWING (I)

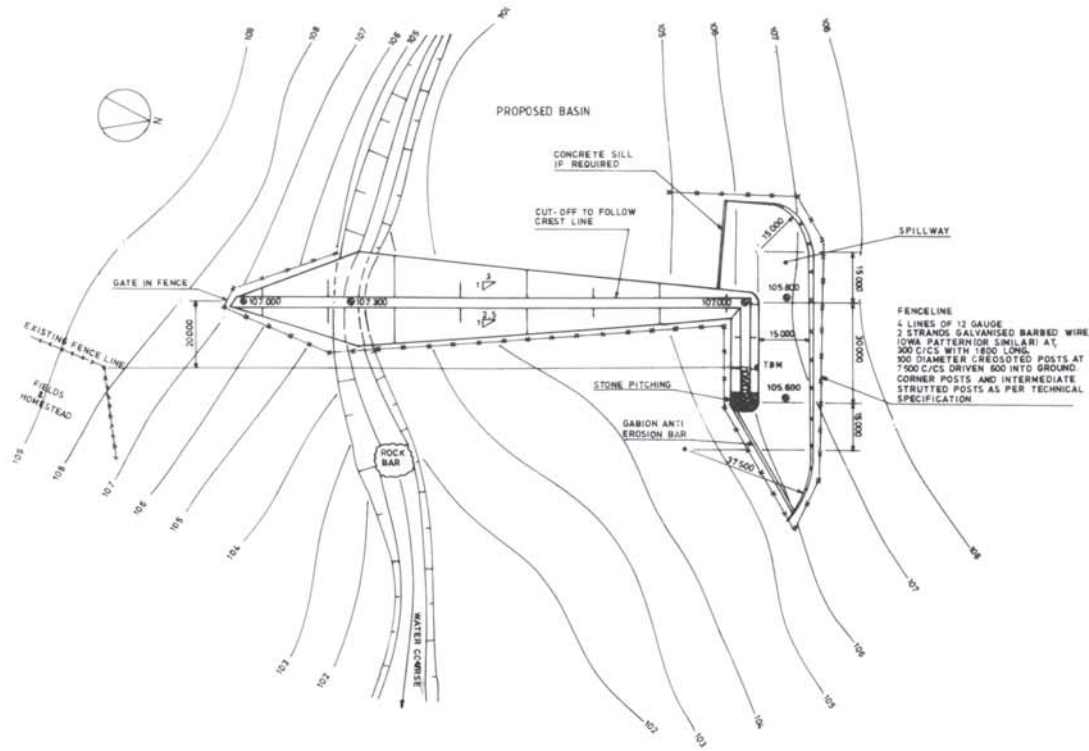

PLAN  
SCALE 1:1000

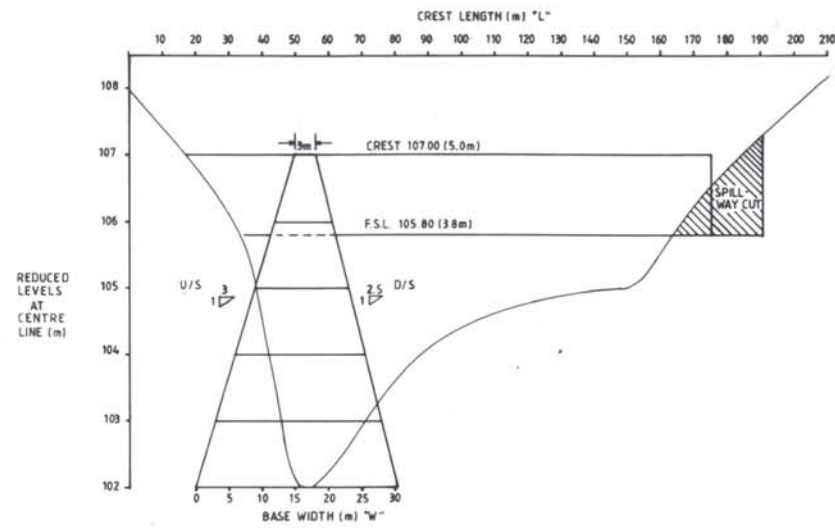

TRAINING BANK VOLUME	$V = HL \frac{C+HS}{2}$ where H=height = 1.1 L=length = 33m C=crest = 3m S=slopes = 4(2+2)	SPILLWAY VOLUME	AREA = 1475m <sup>2</sup> AVERAGE EXCAVATION DEPTH 13m TOTAL VOLUME (net) 1622m <sup>3</sup> (incl. overcut allowance)
	$V = 1.1 \times 33 \frac{3 + 1.1 \times 4}{2} = 225.1m^3$		

AREA OF CROSS-SECTION WxHm <sup>2</sup>	LENGTH OF LONGITUD SECTION L = m	VOLUME WxHxL = m <sup>3</sup>
6.0	150	900.0
11.4	123	1402.2
16.9	63	1064.7
22.4	34	761.6
27.7	16	443.2
EMBANKMENT VOL		4571.7m <sup>3</sup>
TRAINING BANK VOL		225.1m <sup>3</sup>
TOTAL VOL (net)		4796.8m <sup>3</sup>
SETTLEMENT ALLOW 5%		239.8m <sup>3</sup>
FINAL VOL (gross)		5036.6m <sup>3</sup>
[spillway excluded]		

TYPICAL VALLEY CROSS-SECTION AND EARTHWORKS VOL. DETAILS

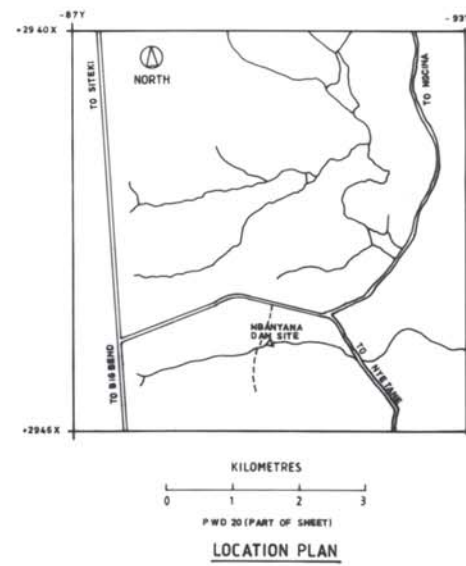
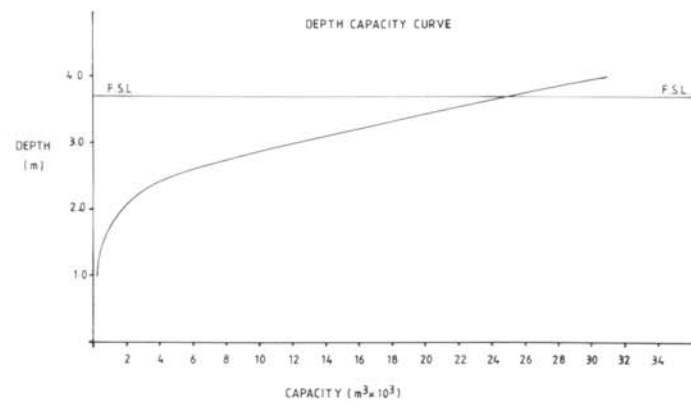

- NOTES
- 1 SPILLWAY 15m WIDE AND 1.20m DEEP
  - 2 EMBANKMENT CREST HEIGHT 5.0m NET (REF. SETTLEMENT, ALLOWANCE)
  - 3 EMBANKMENT SLOPES: 3:1 UPSTREAM 2.5:1 DOWNSTREAM
  - 4 TRAINING BANK SLOPES: 2:1 BOTH SIDES
  - 5 SETTLEMENT ALLOWANCE 5%
  - 6 ALL DIMENSIONS IN MILLIMETRES
  - 7 REDUCED LEVELS FROM ARBITRARY DATUM

DRAWING 1

DESIGNED	DRG. No.	REFERENCE DRAWINGS	No.	DATE	REVISION	MADE	CHKD.	No.	DATE	REVISION	MADE	CHKD.	SCALE
DRAWN													UNLESS OTHERWISE SHOWN
DESIGN CHECK													
DRAWING CHECK													
APPROVED													

**DAM DRAWING (I)**

SCALE

UNLESS OTHERWISE SHOWN

**MANUAL ON SMALL EARTH DAMS**  
A GUIDE TO SITING, DESIGN AND CONSTRUCTION

DESIGNED BY

DRAWN BY

CHECKED BY



**DRAWING 2: DAM DRAWING (II)**

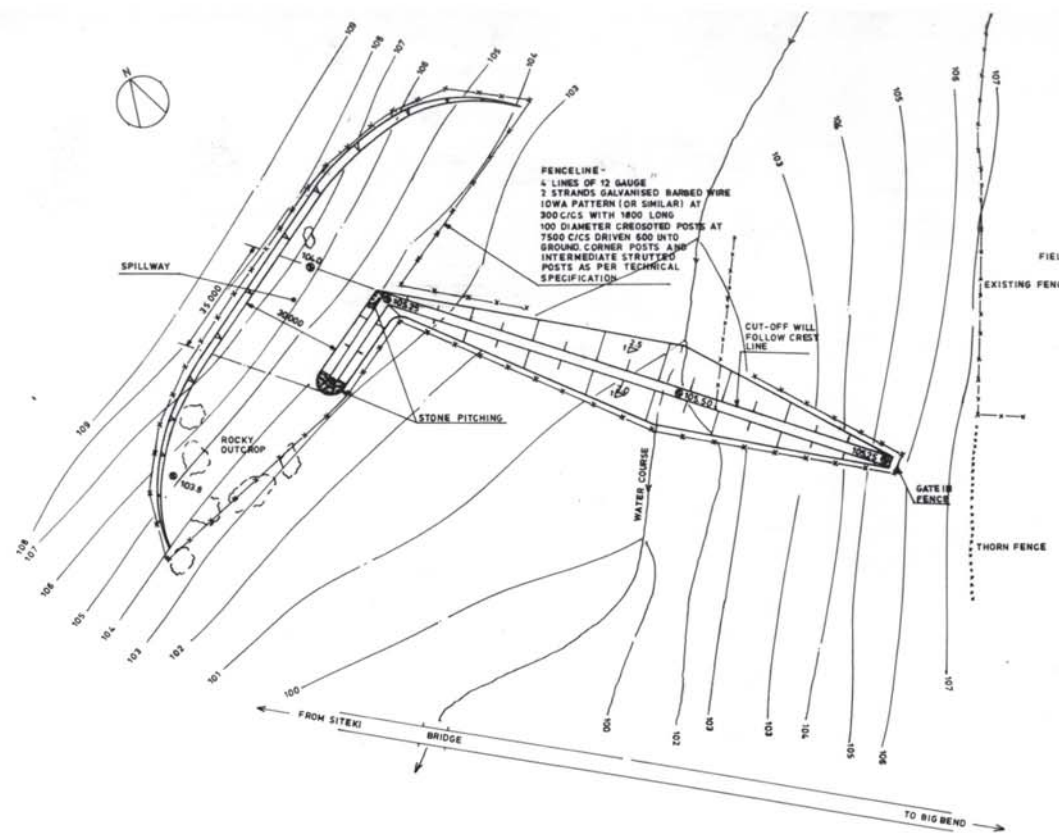

PLAN  
SCALE 1:1000

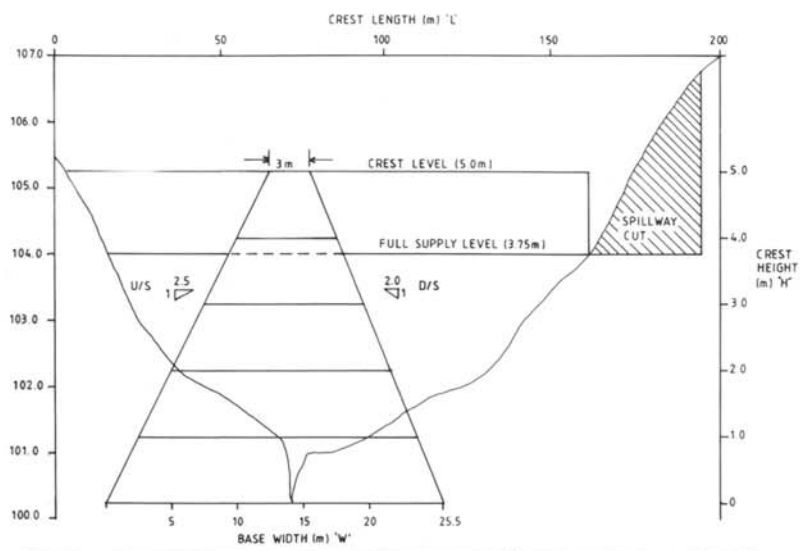

TRAINING BANK:  $V = \frac{HL(C+HS)^2}{2}$  where H = mean height (m) = 1.25  
L = length = 33  
C = crest width (m) = 3  
S = slopes = 4 (2:1)  
 $V = \frac{1.25 \times 33 (3 + 1.25 \times 4)^2}{2} = 226.875 \text{ m}^3$

SPILLWAY VOLUME  
AREA = 7700 m<sup>2</sup>  
AVERAGE EXCAVATION DEPTH = 1.4 m  
VOLUME TO BE EXCAVATED = 10 780.00 m<sup>3</sup>  
(no overcut allowance - rock assumed)

TYPICAL VALLEY CROSS-SECTION AND EARTHWORKS VOLUME DETAILS

AREA OF CROSS SECTION W x H = m <sup>2</sup>	LENGTH OF LONG SECTION L = m	VOLUME W x H x L = m <sup>3</sup>
5.2	152	790.4
9.9	138	1366.2
14.4	110	1584.0
18.0	56	1008.0
23.5	4	94.0

EMBANKMENT VOLUME: 4 893.0 m<sup>3</sup>  
TRAINING BANK VOLUME: 226.9 m<sup>3</sup>  
TOTAL VOLUME (net): 5 119.9 m<sup>3</sup>  
SETTLEMENT ALLOW 5%: 256.0 m<sup>3</sup>  
FINAL VOLUME (gross): 5 375.9 m<sup>3</sup>  
(spillway excluded)

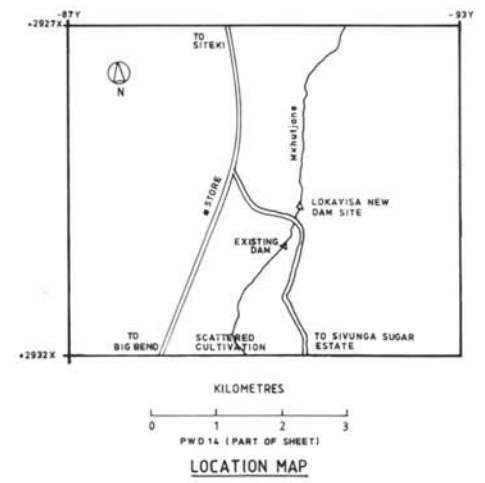
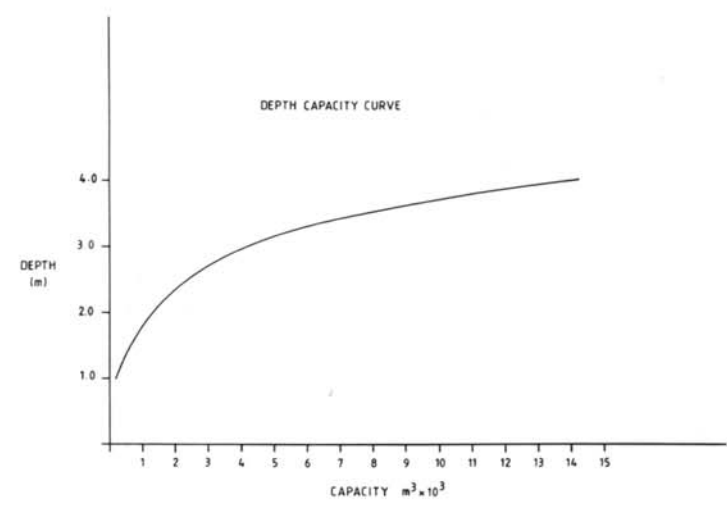

- NOTES
- 1 SPILLWAY 30m WIDE AND 1.25m DEEP
  - 2 EMBANKMENT CREST HEIGHT 5.0m NET (REF SETTLEMENT ALLOWANCE)
  - 3 EMBANKMENT SLOPES - 2.5:1 UPSTREAM, 2.0:1 DOWNSTREAM
  - 4 TRAINING BANK SIDE SLOPES - 2.0:1 BOTH SIDES
  - 5 SETTLEMENT ALLOWANCE 5%
  - 6 ALL DIMENSIONS IN MILLIMETRES
  - 7 REDUCED LEVELS FROM ARBITRARY DATUM

DAM DRAWING (II)

DRAWING 2

DESIGNED	DRG No.	REFERENCE DRAWINGS	No.	DATE	REVISION	MADE	CHKD.	No.	DATE	REVISION	MADE	CHKD.	SCALE
													UNLESS OTHERWISE SHOWN

MANUAL ON SMALL EARTH DAMS  
A GUIDE TO SITING, DESIGN AND CONSTRUCTION

DESIGNED BY

DRAWN BY

CHECKED BY

**DRAWING 3: EMBANKMENT REPAIR**

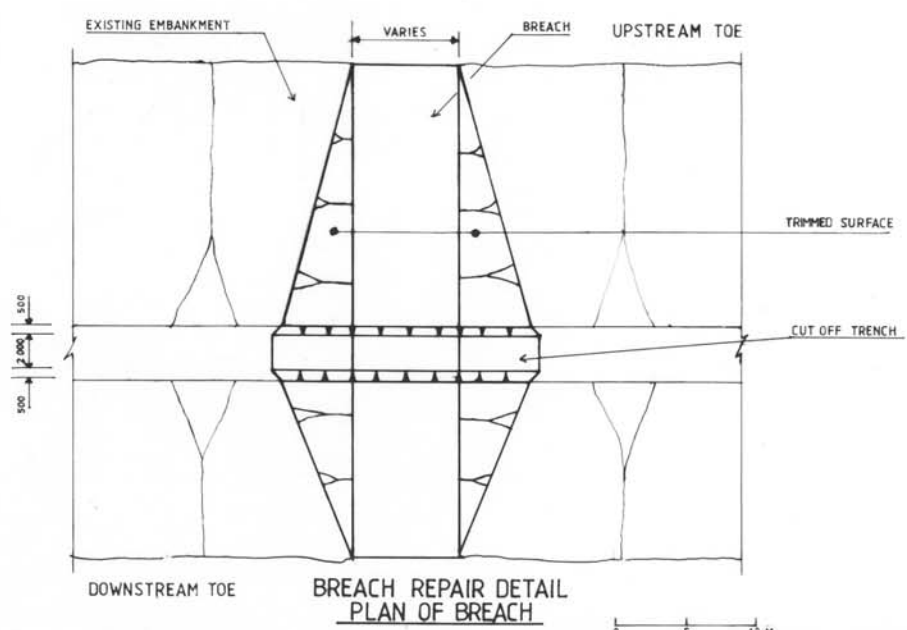
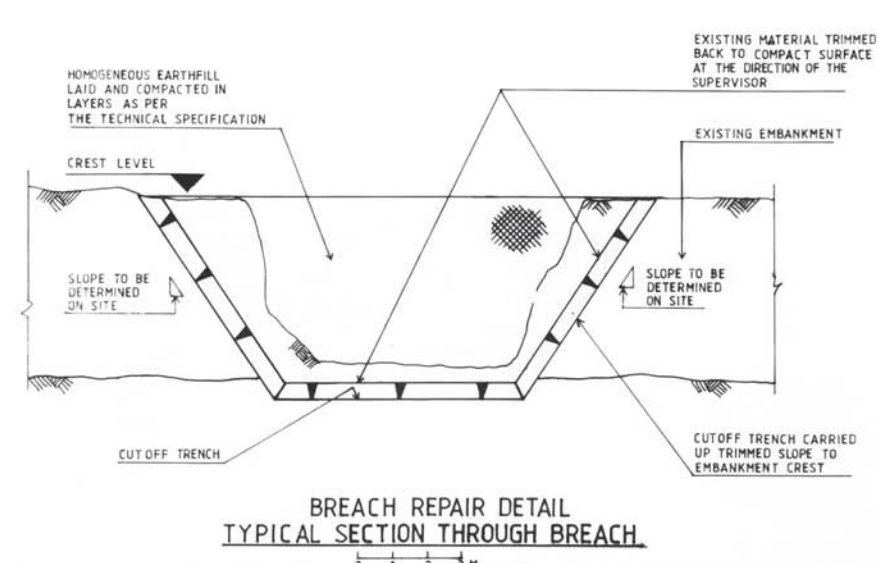
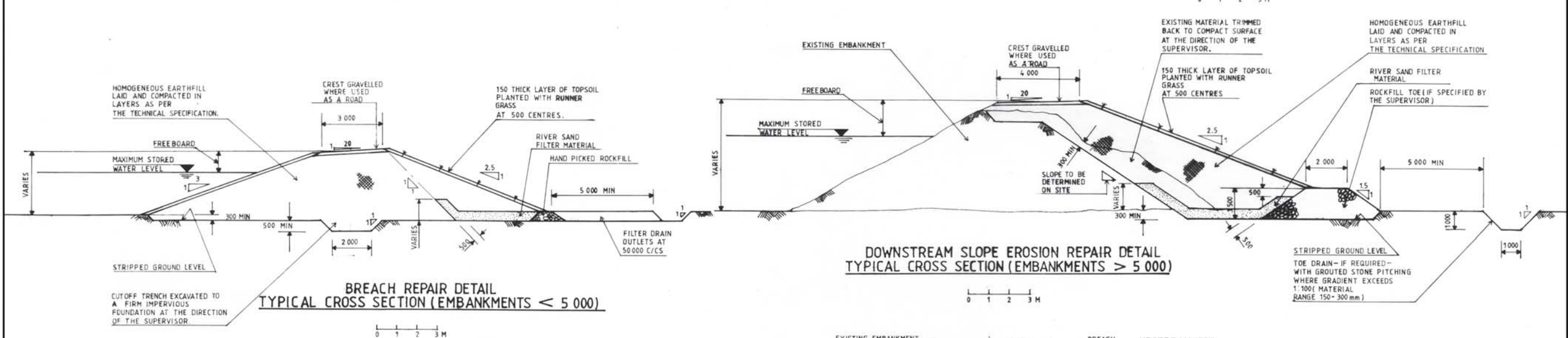
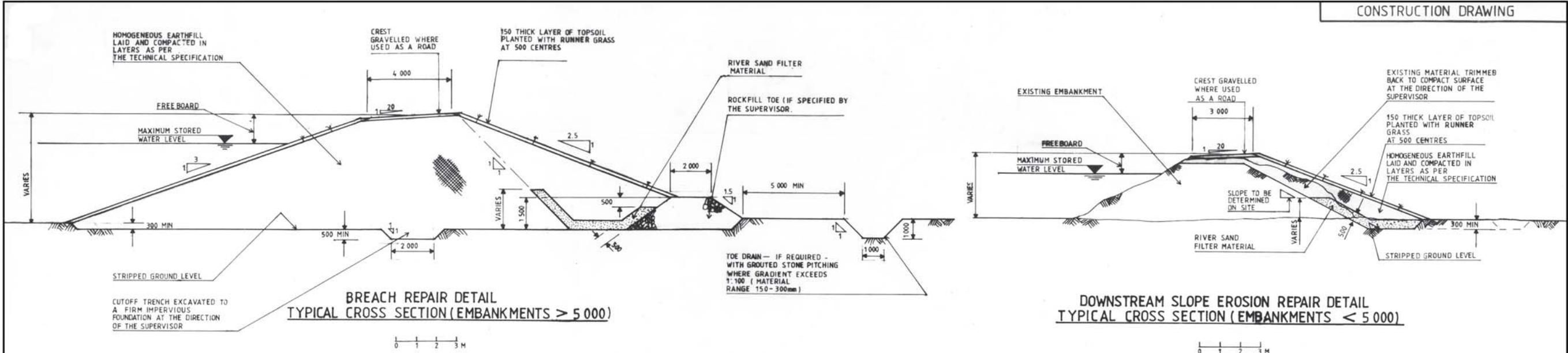

- NOTES**
- (1) DIMENSIONS IN MILLIMETRES
  - (2) DO NOT SCALE - USE FIGURED DIMENSIONS ONLY
  - (3) FILTER MATERIAL GRADINGS TO BE SPECIFIED AFTER OPENING OF EARTHFILL BORROW AREAS
  - (4) ROCKFILL TOE MATERIAL GRADINGS TO BE SPECIFIED AFTER OPENING OF EARTHFILL BORROW AREAS.

DRAWING 3

DESIGNED	DRG. No.	REFERENCE DRAWINGS	No.	DATE	REVISION	MADE	CHKD.	No.	DATE	REVISION	MADE	CHKD.
DRAWN												
DESIGN CHECK												
DRAWING CHECK												
APPROVED												

SCALE  
UNLESS OTHERWISE SHOWN

**EMBANKMENT REPAIR**

**MANUAL ON SMALL EARTH DAMS**  
A GUIDE TO SITING, DESIGN AND CONSTRUCTION

DESIGNED BY	
DRAWN BY	
CHECKED BY	

**DRAWING 4: OUTLET PIPE AND ANCILLARY STRUCTURES**

**CONSTRUCTION DRAWING**

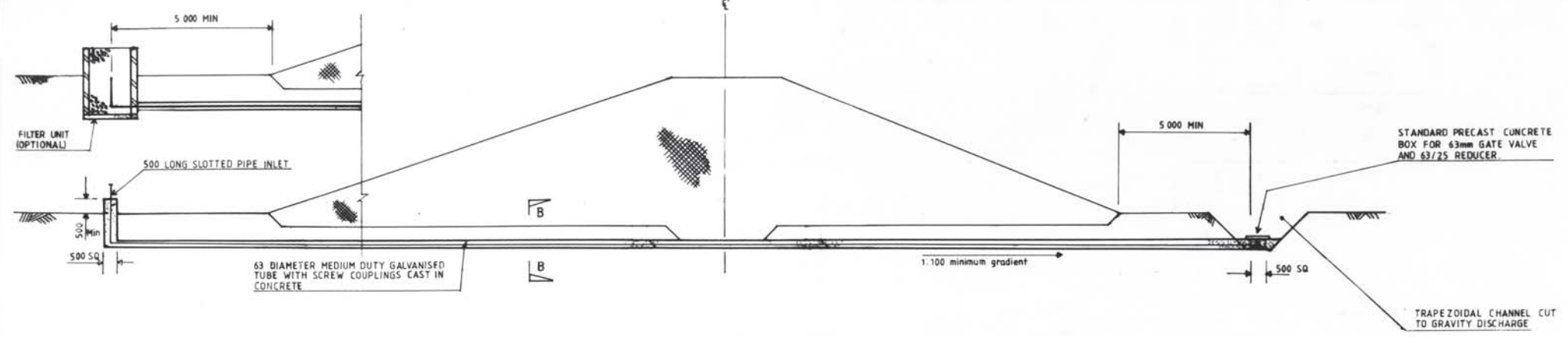

**TYPICAL SECTION THROUGH WATER OUTLET PIPE**

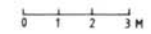

- NOTES**
- (1) ALL REINFORCEMENT ON THIS DRAWING IS DETAILED IN ACCORDANCE WITH BSCP 110 (1972) AS FOLLOWS:
  - (2) **BAR CALLING UP SYSTEM**  

NO. IN GROUP	DIAMETER MM	SPACING M
37	T 16	07 - 250
	MATERIAL TYPE	MARK NUMBER
		POSITION
  - (3) COVER TO REINFORCEMENT TO BE 50 MM, UNLESS STATED OTHERWISE.
  - (4) BENDING TO BE IN ACCORDANCE WITH BS 4466.
  - (5) **MATERIAL TYPE**  
 REINFORCING STEEL SHALL BE IN ACCORDANCE WITH THE REQUIREMENTS OF BS 4449 AND BS 44 THE MATERIAL TYPE IS SHOWN ON THE DRAWING AS FOLLOWS:-  
 R = MILD STEEL BARS GRADE 250  
 T = TYPE 2 DEFORMED BARS GRADE 460/425  
 X = TYPE 1 SQUARE TWISTED COLD WORKED BARS GRADE 460/425
  - (6) IN THE EVENT OF NON-AVAILABILITY OF BAR SIZE SHOWN, THE STEEL AREA, LAP AND ANCHORAGE LENGTHS AT ANY CROSS SECTION MAY BE AMENDED SUBJECT TO THE APPROVAL OF THE ENGINEER.
  - (7) **GENERAL ABBREVIATIONS**  
 N.F. NEAR FACE, F.F. FAR FACE, E.F. EACH FACE  
 B. BOTTOM, T. TOP  
 A.B.R. ALTERNATE BARS REVERSED  
 ALT. ALTERNATE, E.W. EACH WAY  
 STGD. STAGGERED
  - (8) DIMENSIONS IN MILLIMETRES
  - (9) DO NOT SCALE - USE FIGURED DIMENSIONS ONLY

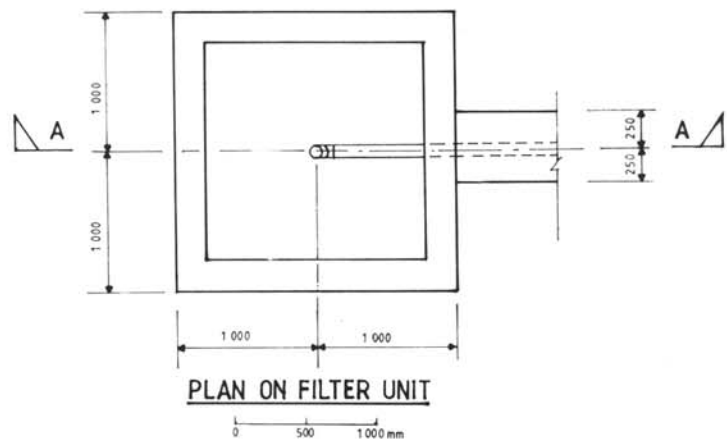

**PLAN ON FILTER UNIT**

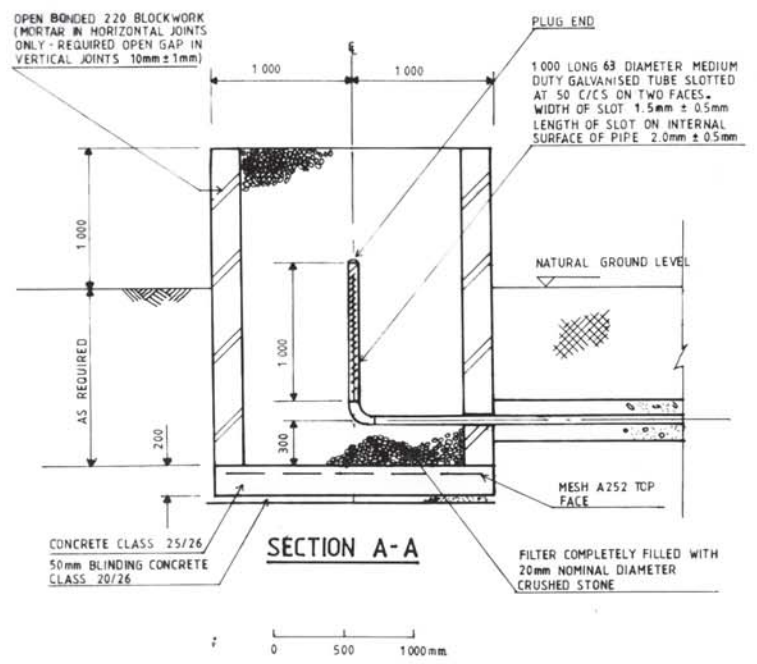

**SECTION A-A**

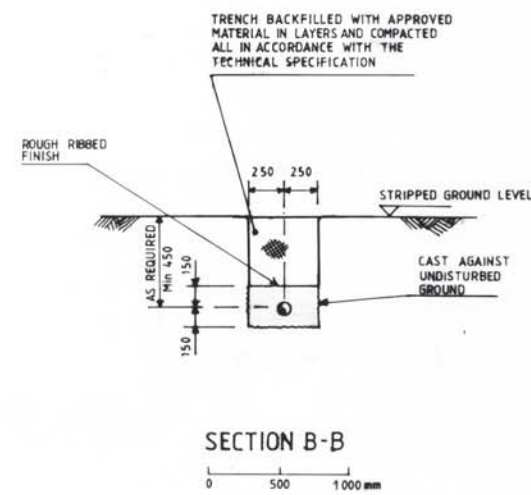

**SECTION B-B**

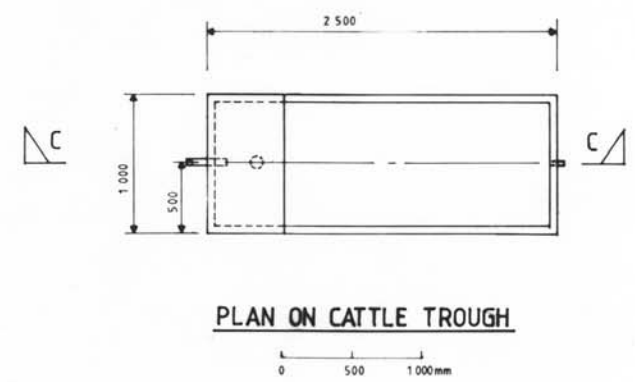

**PLAN ON CATTLE TROUGH**

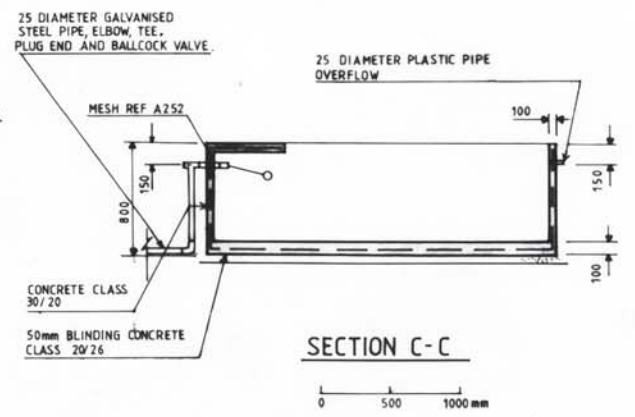

**SECTION C-C**

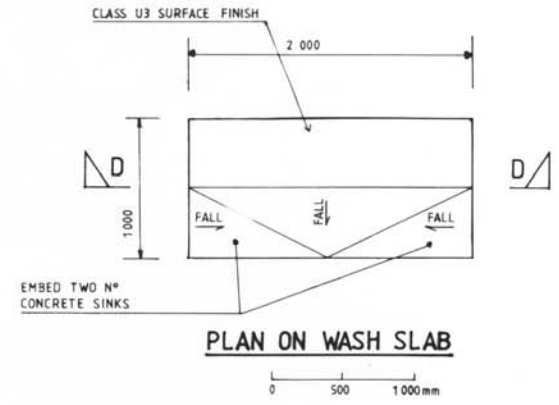

**PLAN ON WASH SLAB**

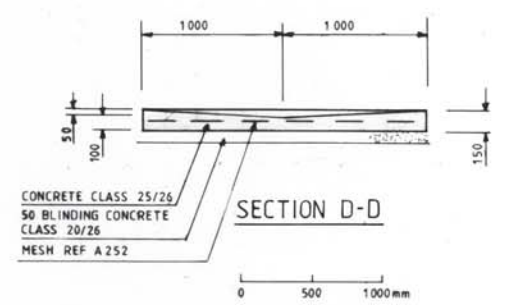

**SECTION D-D**

**DRAWING 4**

DESIGNED	DRG. No.	REFERENCE DRAWINGS	No.	DATE	REVISION	MADE	CHKD.	No.	DATE	REVISION	MADE	CHKD.
DRAWN												
DESIGN CHECK												
DRAWING CHECK												
APPROVED												

**SCALE**  
UNLESS OTHERWISE SHOWN

**OUTLET PIPE AND ANCILLARY STRUCTURES**

**MANUAL ON SMALL EARTH DAMS**  
A GUIDE TO SITING, DESIGN AND CONSTRUCTION

DESIGNED BY	
DRAWN BY	
CHECKED BY	

**DRAWING 5: SPILLWAY DETAILS (I)**

CONSTRUCTION DRAWING

NOTES

(1) ALL REINFORCEMENT ON THIS DRAWING IS DETAILED IN ACCORDANCE WITH BSCP 110 (1972) AS FOLLOWS:

(2) BAR CALLING UP SYSTEM

NO. IN GROUP	DIAMETER MM	SPACING MM
37	T 16	07
		250
		T
		POSITION

MATERIAL TYPE      MARK NUMBER

(3) COVER TO REINFORCEMENT TO BE 40 MM, UNLESS STATED OTHERWISE.

(4) BENDING TO BE IN ACCORDANCE WITH BS 4466.

(5) MATERIAL TYPE

REINFORCING STEEL SHALL BE IN ACCORDANCE WITH THE REQUIREMENTS OF BS 4449 AND BS 4461. THE MATERIAL TYPE IS SHOWN ON THE DRAWINGS AS FOLLOWS:-

R = MILD STEEL BARS GRADE 250

T = TYPE 2 DEFORMED BARS GRADE 460/425

X = TYPE 1 SQUARE TWISTED COLD WORKED BARS GRADE 460/425

(6) IN THE EVENT OF NON-AVAILABILITY OF BAR SIZES SHOWN, THE STEEL AREA, LAP AND ANCHORAGE LENGTHS AT ANY CROSS SECTION MAY BE AMENDED SUBJECT TO THE APPROVAL OF THE ENGINEER.

(7) GENERAL ABBREVIATIONS

N.F. NEAR FACE, F.F. FAR FACE, E.F. EACH FACE,  
B. BOTTOM, T. TOP  
A.B.R. ALTERNATE BARS REVERSED  
ALT. ALTERNATE, E.W. EACH WAY,  
STGD. STAGGERED

(8) DIMENSIONS IN MILLIMETRES.

(9) ELEVATION IN METRES ABOVE ARBITRARY DATUM.

(10) DO NOT SCALE - USE FIGURED DIMENSIONS.

(11) GABION BASKETS TO BE CONSTRUCTED IN ACCORDANCE WITH THE TECHNICAL SPECIFICATION.

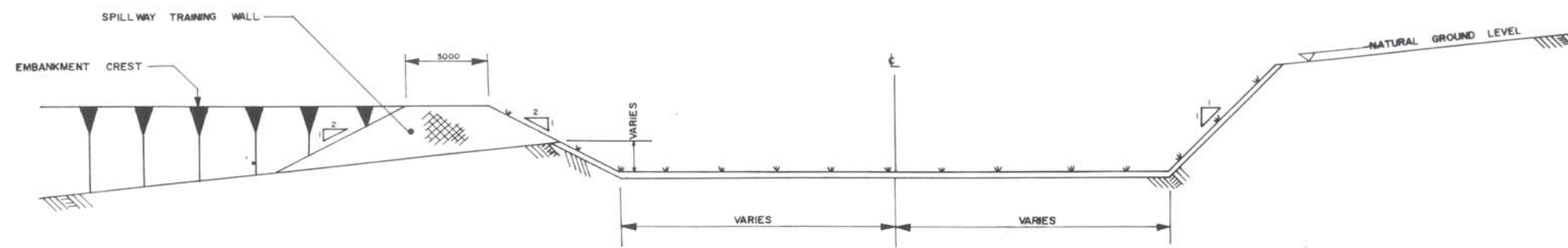

SECTION A-A

0 1 2 3 4 5 METRES

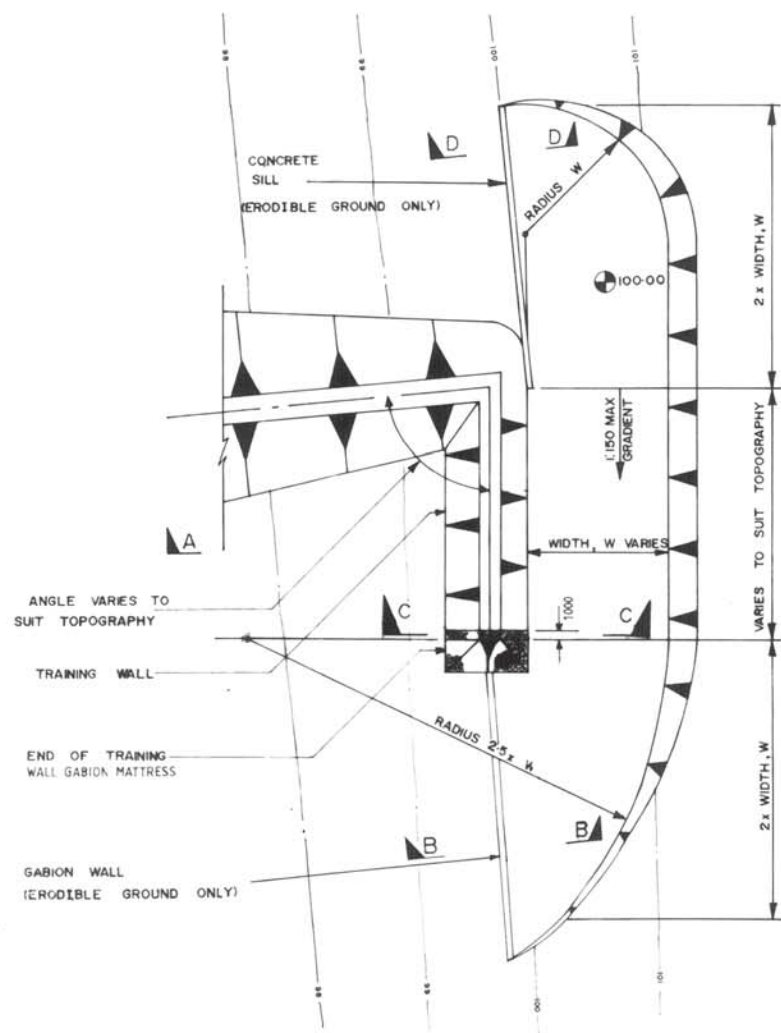

TYPICAL SPILLWAY ARRANGEMENT - PLAN

0 5 10 15 20 METRES

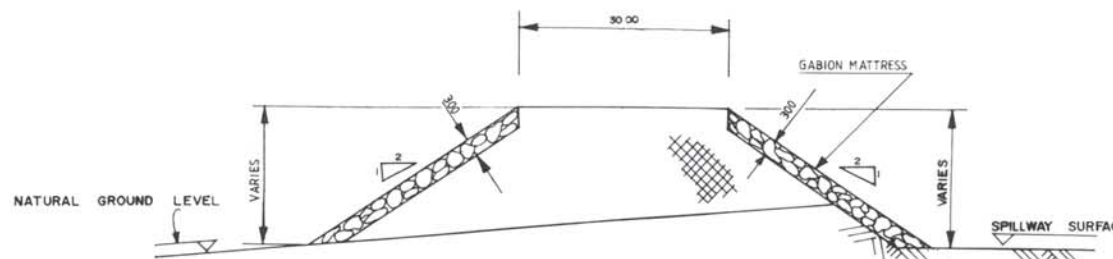

SECTION C-C

0 1 2 3 METRES

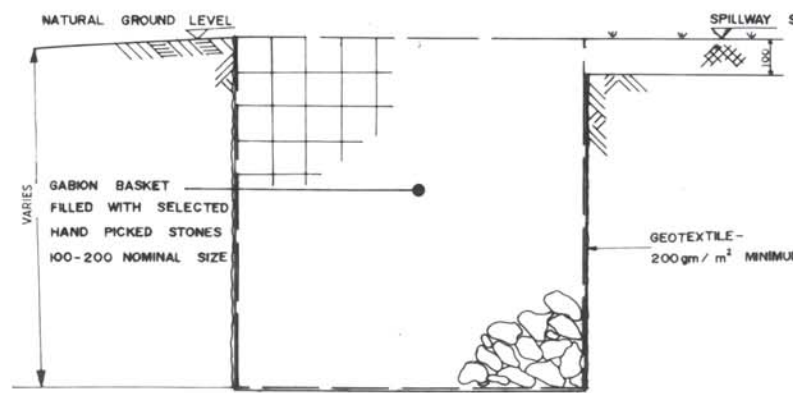

SECTION B-B - GABION WALL

0 100 200 300 400 MILLIMETRES

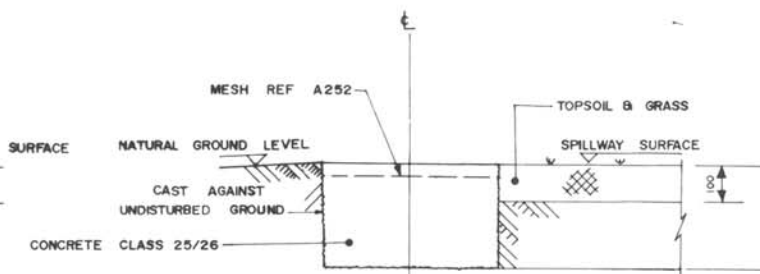

SECTION D-D

CONCRETE SILL

0 100 200 300 400 MILLIMETRES

SPILLWAY DETAILS (I)

DRAWING 5

DESIGNED	DRG. No.	REFERENCE DRAWINGS	No.	DATE	REVISION	MADE	CHKD.	No.	DATE	REVISION	MADE	CHKD.
DRAWN												
DESIGN CHECK												
DRAWING CHECK												
APPROVED												

SCALE  
UNLESS OTHERWISE SHOWN

MANUAL ON SMALL EARTH DAMS  
A GUIDE TO SITING, DESIGN AND CONSTRUCTION

DESIGNED BY	
DRAWN BY	
CHECKED BY	



**DRAWING 6: SPILLWAY DETAILS (II)**

- NOTES
1. Dimensions in millimetres
  2. Do not scale - use figured dimensions only.
  3. Gabion baskets and mattresses to be constructed as detailed in the Technical Specification.
  4. Trimmed gulley face slopes shown as 2:1 approximate only - actual slope to be determined on site.
  5. Gabions to be laid against excavated surfaces only - not against fill.

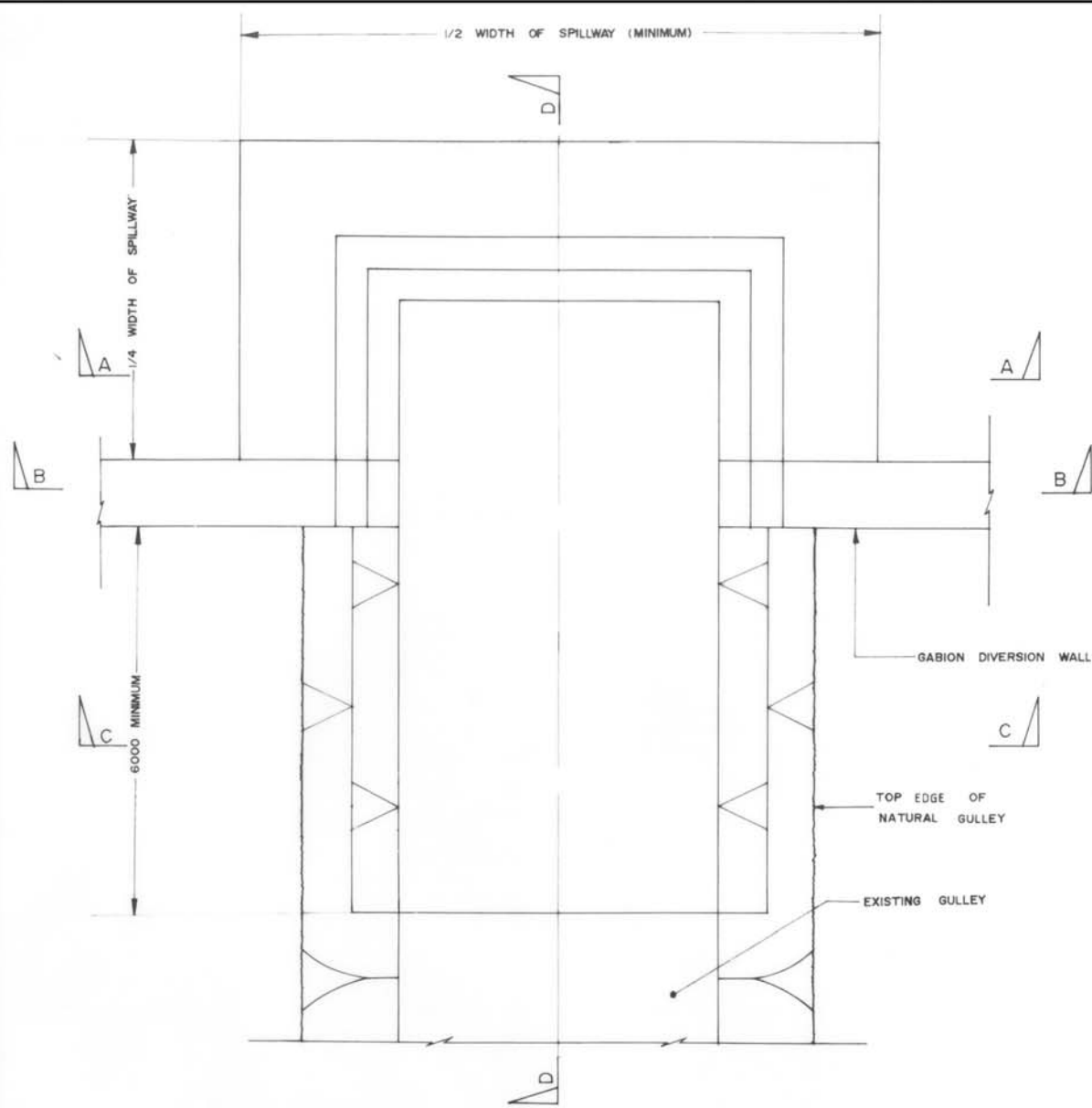

GABION STRUCTURE PLAN

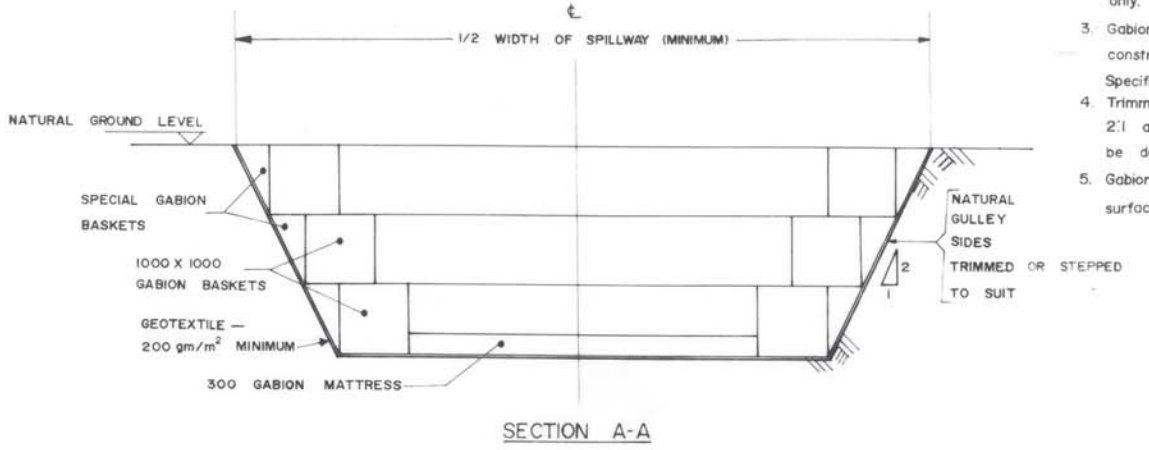

SECTION A-A

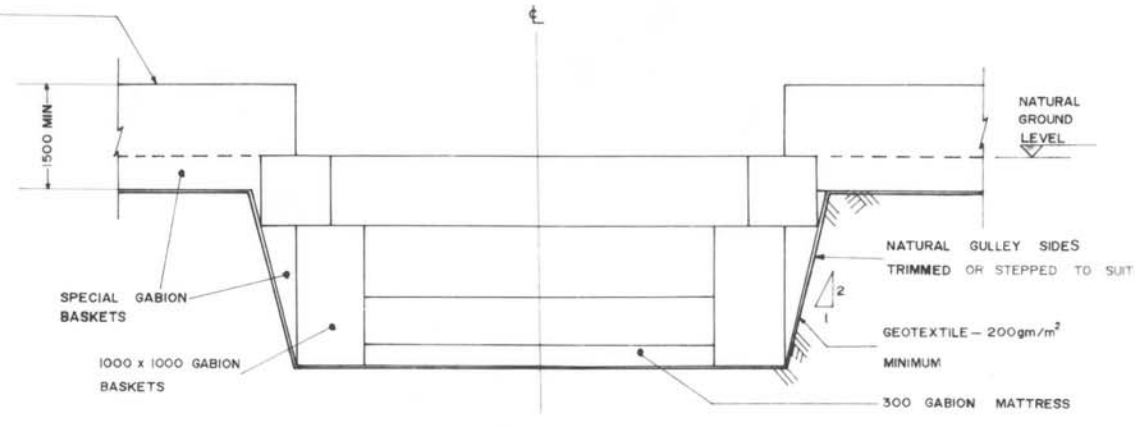

SECTION B-B

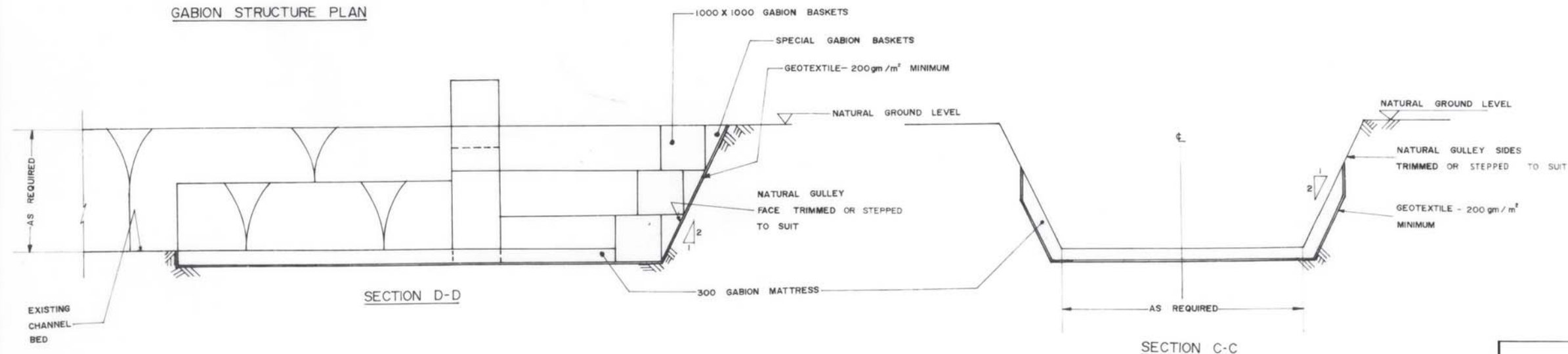

SECTION D-D

SECTION C-C

SPILLWAY DETAILS (II)

DRAWING 6

DESIGNED	DRG No.	REFERENCE DRAWINGS	No.	DATE	REVISION	MADE	CHKD	No.	DATE	REVISION	MADE	CHKD	SCALE
DRAWN													UNLESS OTHERWISE SHOWN
DESIGN CHECK													
DRAWING CHECK													
APPROVED													

SCALE  
UNLESS OTHERWISE SHOWN

MANUAL ON SMALL EARTH DAMS  
A GUIDE TO SITING, DESIGN AND CONSTRUCTION

DESIGNED BY: \_\_\_\_\_  
DRAWN BY: \_\_\_\_\_  
CHECKED BY: \_\_\_\_\_

# FAO TECHNICAL PAPERS

## FAO IRRIGATION AND DRAINAGE PAPERS

1	Irrigation practice and water management, 1972 (Ar* E* F* S*)	39	Lysimeters, 1982 (C E* F* S*)
1 Rev.1	Irrigation practice and water management, 1984 (I)	40	Organization, operation and maintenance of irrigation schemes, 1982 (C E* F S*)
2	Irrigation canal lining, 1971 (New edition, 1977, available in E, F and S in the FAO Land and Water Development Series, No. 1)	41	Environmental management for vector control in rice fields, 1984 (E* F* S*)
3	Design criteria for basin irrigation systems, 1971 (I*)	42	Consultation on irrigation in Africa, 1987 (F I)
4	Village irrigation programmes - a new approach in water economy, 1971 (F I*)	43	Water lifting devices, 1986 (F I)
5	Automated irrigation, 1971 (E* F* S*)	44	Design and optimization of irrigation distribution networks, 1988 (F I)
6	Drainage of heavy soils, 1971 (E* F* S*)	45	Guidelines for designing and evaluating surface irrigation systems, 1989 (I)
7	Salinity seminar, Baghdad, 1971 (F I*)	46	CROPWAT – a computer program for irrigation planning and management, 1992 (E F* S*)
8	Water and the environment, 1971 (E* F* S*)	47	Wastewater treatment and use in agriculture, 1992 (I)
9	Drainage materials, 1972 (E* F* S*)	48	The use of saline waters for crop production, 1993 (I)
10	Integrated farm water management, 1971 (E* F* S*)	49	CLIMWAT for CROPWAT, 1993 (I)
11	Planning methodology seminar, Bucharest, 1972 (E* F*)	50	Le pompage éolien, 1994 (F)
12	Farm water management seminar, Manila, 1972 (I*)	51	Prospects for the drainage of clay soils, 1995 (I)
13	Water use seminar, Damascus, 1972 (F* I*)	52	Reforming water resources policy, 1995 (I)
14	Trickle irrigation, 1973 (E* F* S*)	53	Environmental impact assessment of irrigation and drainage projects, 1995 (I)
15	Drainage machinery, 1973 (F* I*)	54	Crues et apports, 1996 (F)
16	Drainage of salty soils, 1973 (C* E* F* S*)	55	Control of water pollution from agriculture, 1996 (E* S)
17	Man's influence on the hydrological cycle, 1973 (E* F* S*)	56	Crop evapotranspiration, 2006 (E S)
18	Groundwater seminar, Granada, 1973 (E* F S*)	57	Soil salinity assessment, 1999 (I)
19	Mathematical models in hydrology, 1973 (I)	58	Transfer of irrigation management services: guidelines, 1999 (E F R S)
20/1	Water laws in Moslem countries - Vol. 1, 1973 (F* I*)	59	Performance analysis of on-demand pressurized irrigation systems, 2000 (I)
20/2	Water laws in Moslem countries - Vol. 2, 1978 (F I)	60 Rev.1	Materials for subsurface land drainage systems, 2005 (E)
21	Groundwater models, 1973 (I)	61	Agricultural drainage water management in arid and semi-arid areas, 2002 (I)
22	Water for agriculture - index, 1973 (E/F/S*)	62	Guidelines and computer programs for the planning and design of land drainage systems, 2007 (I)
23	Simulation methods in water development, 1974 (E* F* S*)	63	Modernizing Irrigation Management – the MASSCOTE approach. Mapping System and Services for Canal Operation Techniques, 2007 (I)
24	Crop water requirements, (rev.) 1977 (C* E F S)	64	Manual on small earth dams. A guide to siting, design and construction, 2010 (E)
25	Effective rainfall, 1974 (C* E* F* S*)		
26/1	Small hydraulic structures – Vol. 1, 1975 (E* F* S*)		
26/2	Small hydraulic structures – Vol. 2, 1975 (E* F* S*)		
27	Agro-meteorological field stations, 1976 (E* F* S*)		
28	Drainage testing, 1976 (E* F* S*)		
29	Water quality for agriculture, 1976 (E* F* S*)		
29 Rev.1	Water quality for agriculture, 1985 (C** E* F* S*)		
30	Self help wells, 1977 (I)*		
31	Groundwater pollution, 1979 (C* E* S)		
32	Deterministic models in hydrology, 1979 (I)*	Ar	– Arabic
33	Yield response to water, 1979 (C* E F S)	C	– Chinese
34	Corrosion and encrustation in water wells, 1980 (I)	E	– English
35	Mechanized sprinkler irrigation, 1982 (C E* F S*)	F	– French
36	Localized irrigation, 1980 (Ar C E* F S*)	P	– Portuguese
37	Arid zone hydrology, 1981 (C I)	R	– Russian
38	Drainage design factors, 1980 (Ar C E F S)	S	– Spanish
		Multil	– Multilingual
		*	Out of print
		**	In preparation

# Manual on small earth dams

A guide to siting, design and construction

This publication aims to fill a void of practical guidelines for the construction of small earth dams. It presents readers with sound, reliable and practical source material to improve dam siting and design capacity in rural areas, to introduce a beneficiary and gender sensitive approach and to enhance safety and competence in construction. A section also provides convenient guidance on costing, drafting tenders and awarding contracts.

The manual is primarily aimed at technicians and others with knowledge of engineering and basic irrigation systems and processes to apply the concepts, techniques and methods proposed, using simple and straightforward design and construction procedures.

ISBN 978-92-5-106547-1 ISSN 0254-5284



9 789251 065471

I1531E/1/04.10/2000