

DESIGN MANUAL ON BASIC WOOD HARVESTING TECHNOLOGY

BOOKLET 1

FELLING, DEBRANCHING AND CROSSCUTTING

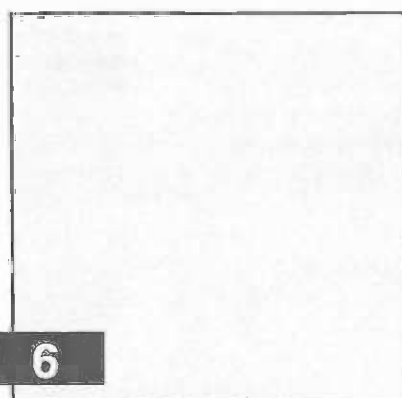
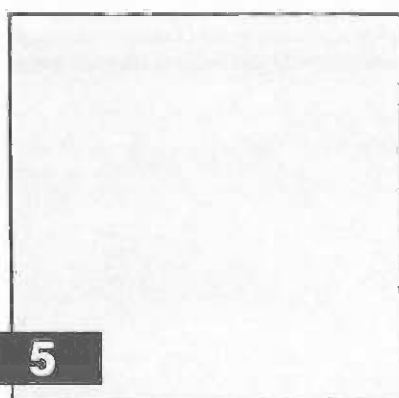
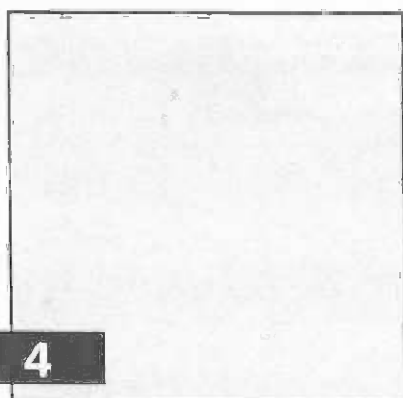
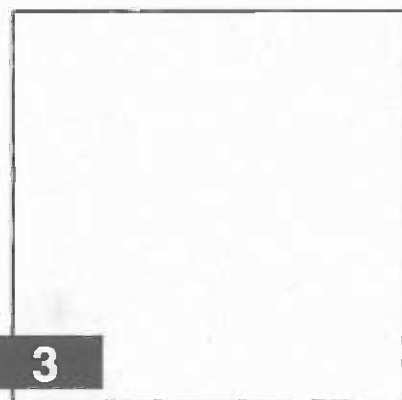
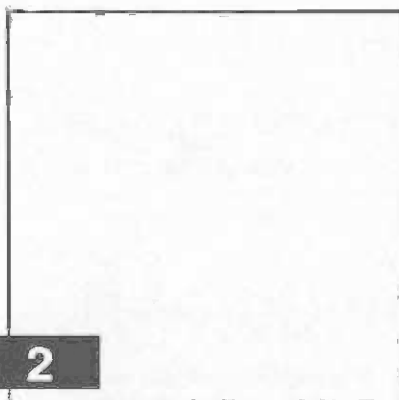
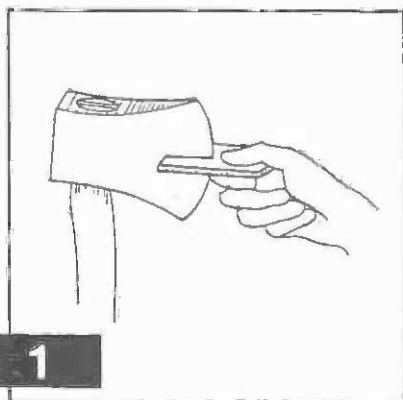

The designations employed and the presentation of material in this publication do not imply the expression of any opinion whatsoever on the part of the Food and Agriculture Organization of the United Nations concerning the legal status of any country, territory, city or area or of its authorities, or concerning the delimitation of its frontiers or boundaries.

M-39
ISBN 92-5-102537-1

All rights reserved. No part of this publication may be reproduced, stored in a retrieval system, or transmitted in any form or by any means, electronic, mechanical, photocopying or otherwise, without the prior permission of the copyright owner. Applications for such permission, with a statement of the purpose and extent of the reproduction, should be addressed to the Director, Publications Division, Food and Agriculture Organization of the United Nations, Via delle Terme di Caracalla, 00100 Rome, Italy.

© FAO 1989

Contents

1. Axe handle
2. Pattern for an axe handle
3. Hanging an axe handle
4. Gauge for axe blades 1
5. Gauge for axe blades 2
6. Log vice for sharpening axe blades
7. Grindstone attachment for
axe blades
8. Axe blade guard
9. Wooden frame bowsaw
10. Stand for filing crosscut saws
11. Jointer for saws 1
12. Jointer for saws 2
13. Saw set
14. Set gauge
15. Raker gauge
16. Sawblade guard
17. Log jack 1
18. Log jack 2
19. Log jack 3
20. Sawhorse 1
21. Sawhorse 2
22. Sawhorse 3
23. Wooden wedges
24. Control for trees felled on slopes

Symbols and abbreviations used

°	Degree (angle)	
∅	Diameter measurement	
kg	Kilogram	= 2.205 pounds (lb)
m	Metre	= 1.094 yards (yd)
mm	Millimetre	= 0.0394 inch (in)

Note

Additional valuable information on the kinds of tools shown in this booklet can be found in FAO Forestry Paper 36, *Basic Technology in Forest Operations* (ISBN 92-5-101260-1).

1. Axe handle

Material

Choose a piece of hardwood, either from the butt of a young tree or from the sapwood of an older tree. Use well-seasoned wood. The grain of the wood must be straight and run parallel to the length of the handle. It should have no knots.



Parallel grain is best

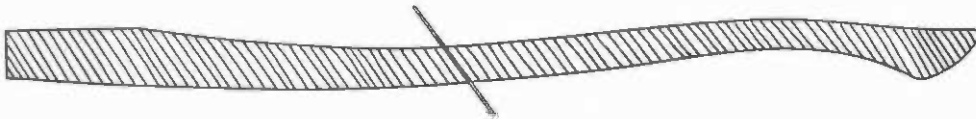

Cross grain will break easily

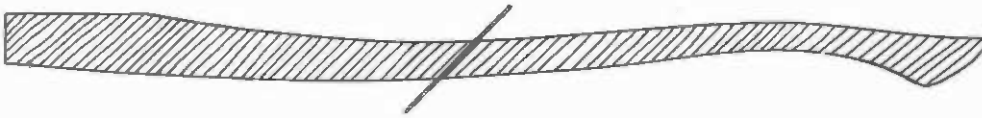

Face grain will warp

2. Pattern for an axe handle

Material

A well-seasoned piece of wood with straight grain.

Instructions

The axe handle should reach from the cutter's armpit to finger tips, and from his hand to the ground (1). If an axe handle is not available as a model, use the pattern (2). Trace the outline of the side of the handle on to the piece of wood (3). Cut away excess wood on the top with a chisel and saw (4). Trace the outline of the top of the handle (5). Cut away excess wood. Finish shaping the handle with a knife. File and sandpaper to the dimensions of the cross sections shown below (6). The finished handle should be comfortable to hold.

1

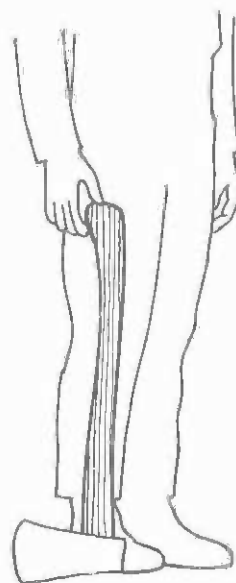
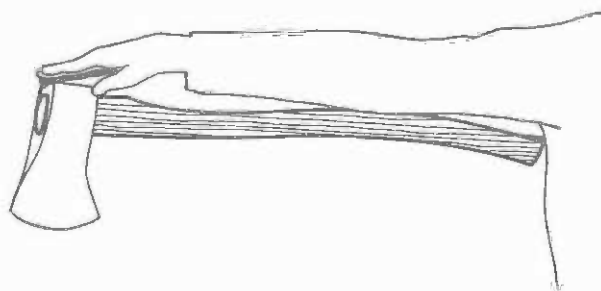

2

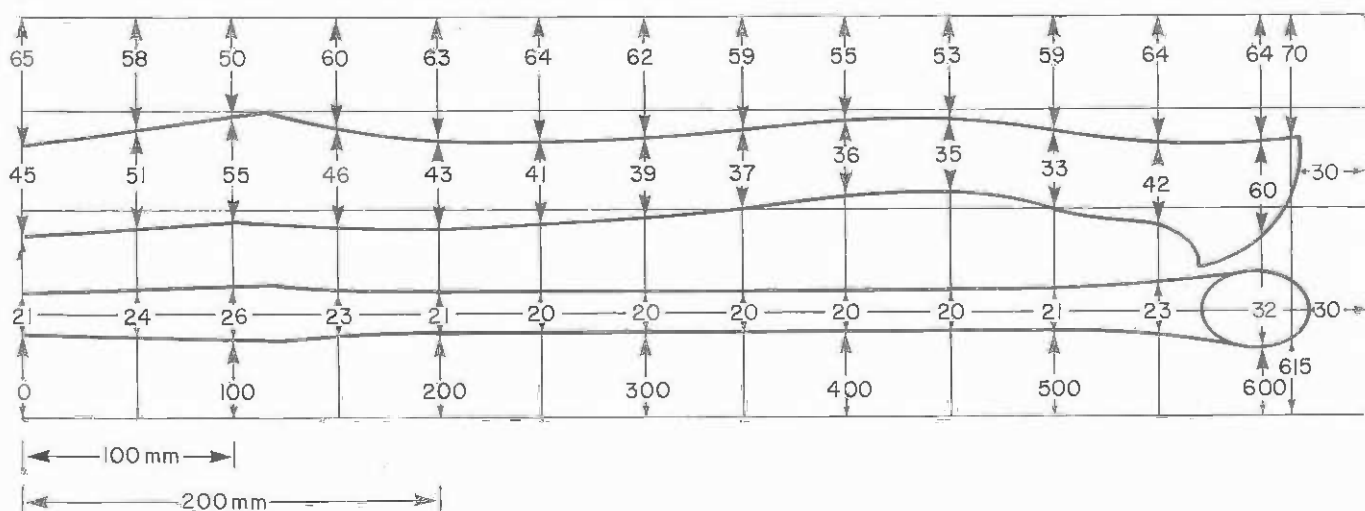

3

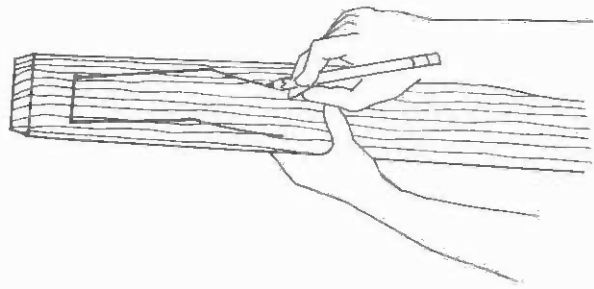

4

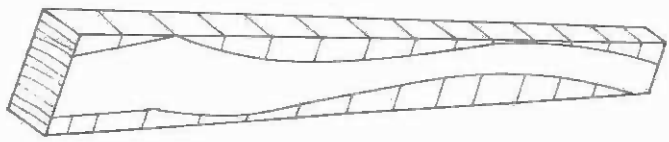

5

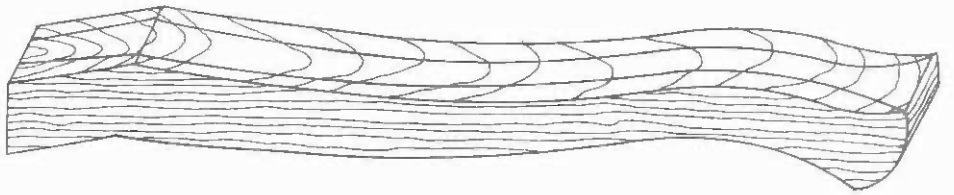

6

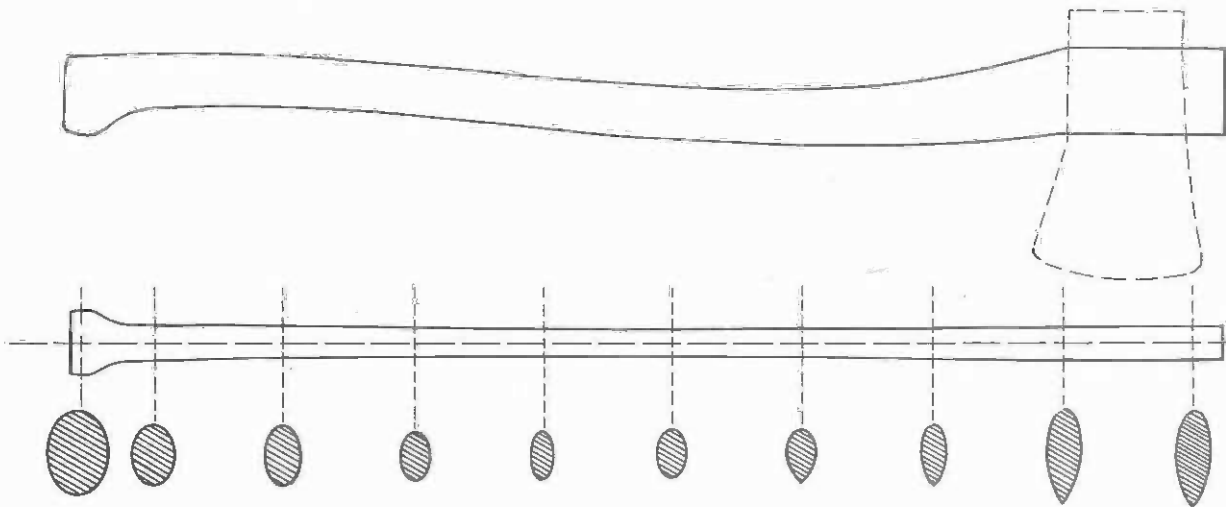

3. Hanging an axe handle

Material

Axe handle, axehead.

Instructions

Using a rasp, shape the end of the handle to fit the eye of the axehead (1). Insert the handle into the head and test for alignment. The line of sight should run through the blade of the axehead and through the knob on the end of the axe handle (2). Remove the handle and saw a slot of approximately 40 mm into the end (3). Cut a hardwood wedge for the slot (4). Insert the handle in the axehead and drive the wedge into the slot (5). Test again for alignment (6). Cut off the excess handle (7). A well-hung axehead will rest on the centre of the blade (8).

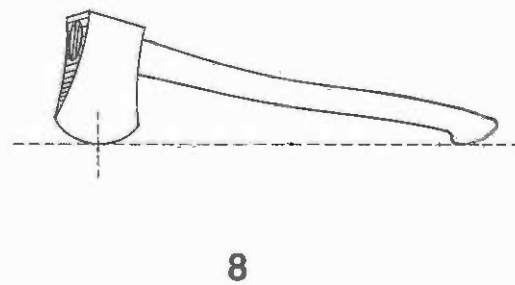
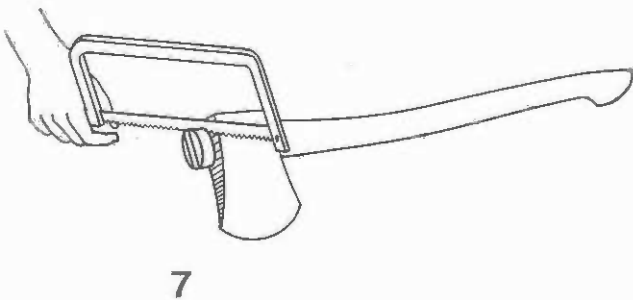
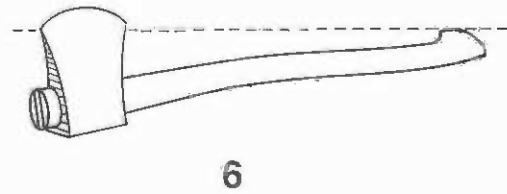
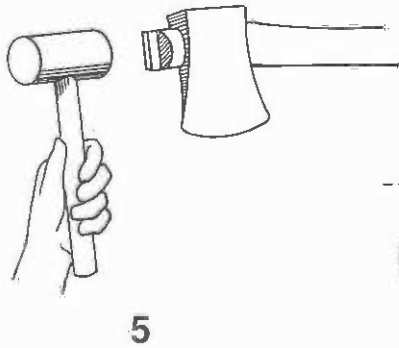
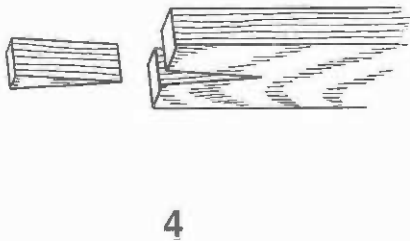
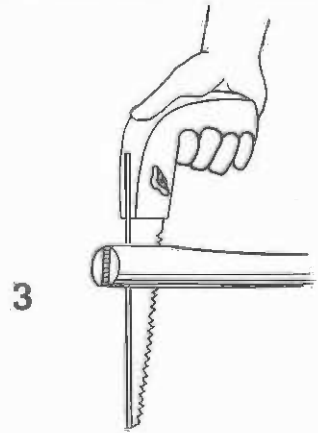
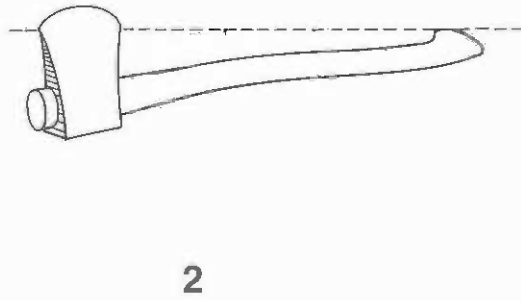
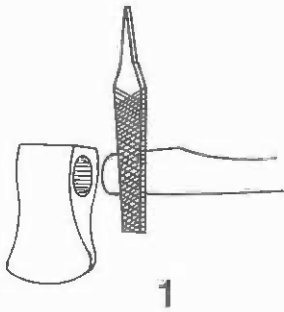

4. Gauge for axe blades 1

Use

To test axe-blade profile.

Material

A piece of sheet iron or aluminium 70 x 30 x 5 mm.

Instructions

Transfer the pattern on to a piece of metal (1). Using a hacksaw, cut a notch 50 mm deep and varying in width from 0 to 10 mm. File the notch smooth. The gauge measures the dimensions of the taper (2). When the gauge fits exactly the blade has the proper profile (3). If the blade is too thick to fit the gauge, it should be ground or filed until it does.

1

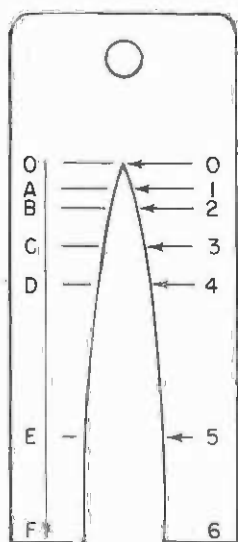

2

Distance from edge of blade

- A. 2.5 mm
- B. 5.0 mm
- C. 10.0 mm
- D. 15.0 mm
- E. 35.0 mm
- F. 50.0 mm

Thickness of blade

- 1. 1.5 mm
- 2. 2.5 mm
- 3. 4.5 mm
- 4. 7.0 mm
- 5. 8.5 mm
- 6. 10.0 mm

3

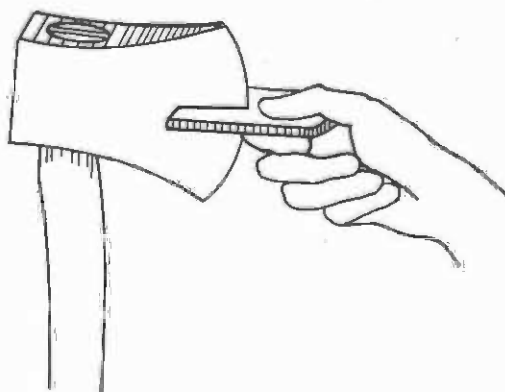

5. Gauge for axe blades 2

Use

To test axe-blade profile.

Material

A piece of sheet iron or aluminium 70 x 70 x 5 mm.

Instructions

Transfer the pattern on to a piece of metal (1). Using a hacksaw, cut the notches. File the notches smooth. The notches measure the dimensions of the taper (2). For the most efficient use, the taper of the blade must vary depending on whether it is for hardwood or softwood (3).

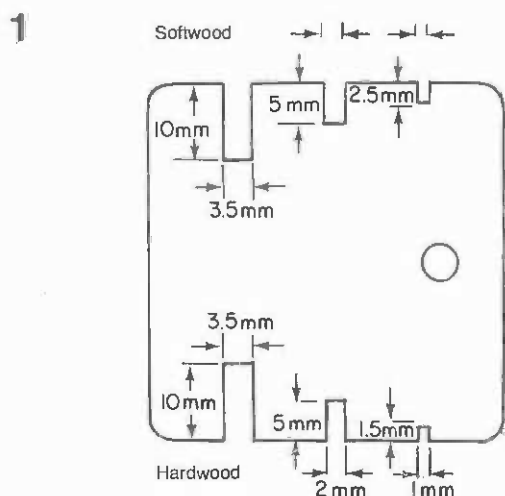

2

	Distance from edge of blade	Thickness of axe blade
Softwood	2.5 mm	1.0 mm
	5.0 mm	2.0 mm
	10.0 mm	3.5 mm
Hardwood	1.5 mm	1.0 mm
	5.0 mm	2.0 mm
	10.0 mm	3.5 mm

3

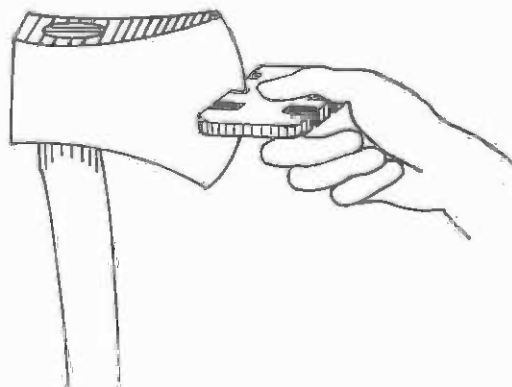

6. Log vice for sharpening axe blades

Use

To hold an axehead in place when filing the blade.

Material

A length of heavy log.

Instructions

Chop a wedge-shaped notch in the log. The angle of the notch should be about 30°. The notch should be wide enough to hold the axehead firmly. The blade is facing upward, ready to be filed.

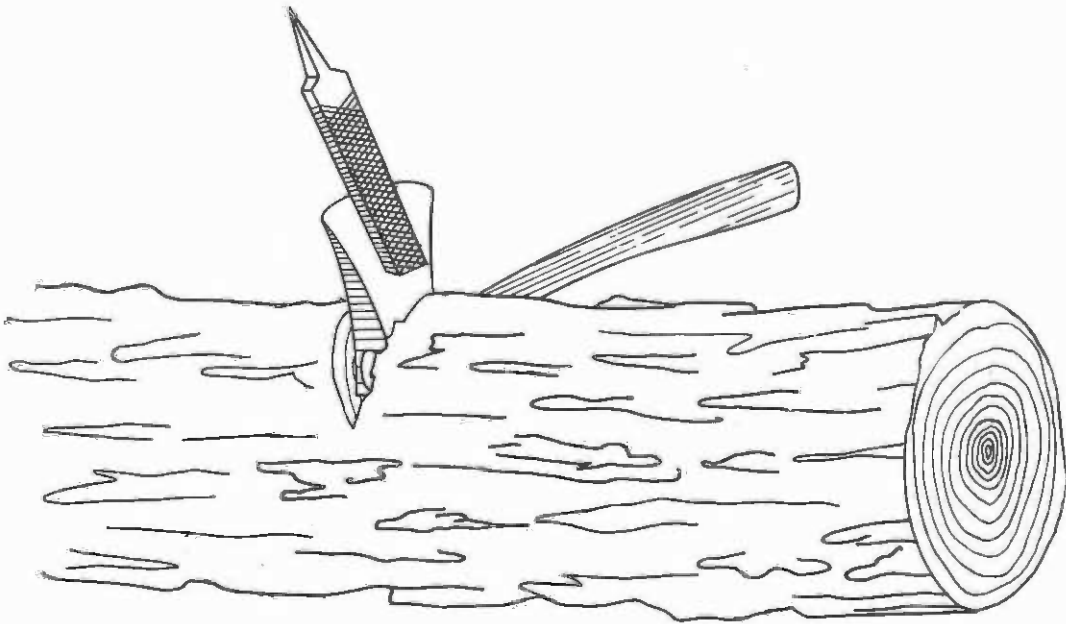

7. Grindstone attachment for axe blades

Use

To apply pressure to an axehead held against a grindstone.

Material

1 piece of wood 700 x 100 x 50 mm for the lever arm,
1 piece of wood of an appropriate height for the upright
200 x 30 mm, about 20 nails 50 mm long.

Instructions

Shape the lever arm using the pattern (1). Drive the nails through the upright and fasten it to the frame of the grindstone at the centre line of the grinding wheel. Push the end of the lever arm into one of the nails. The upright becomes the fulcrum to the lever (2). The axehead is fitted into the notch in the lever arm and pushed against the grindstone.

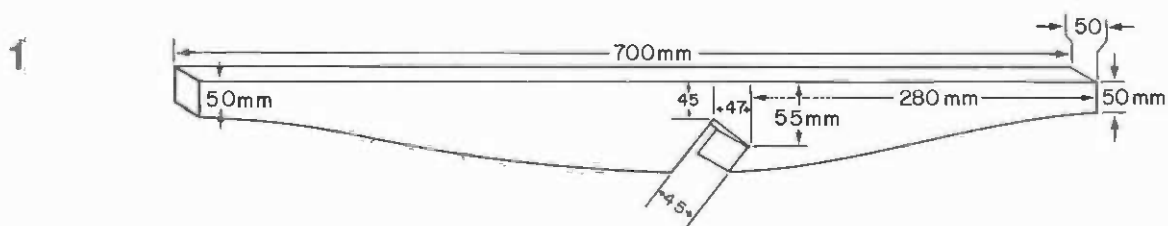

2

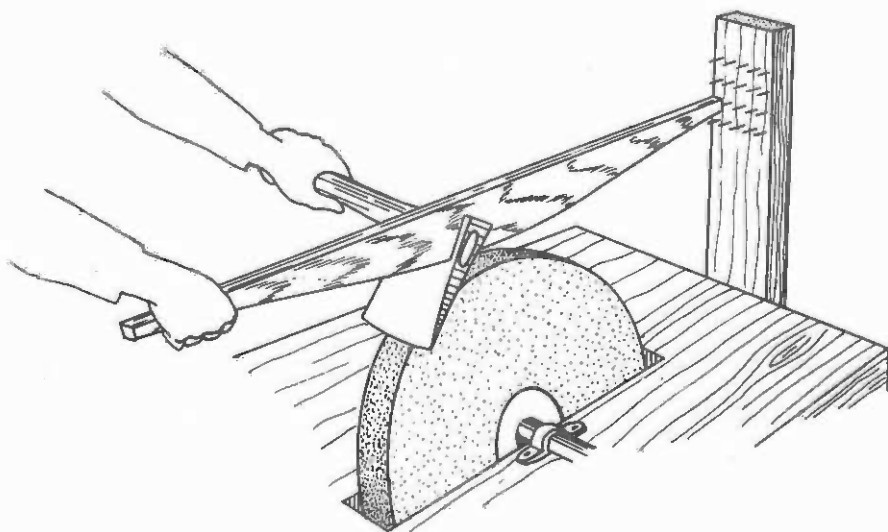

8. Axe blade guard

Use

To cover an axe blade not in use.

Material

A piece of rubber hose 150 mm long, 2 pieces of old inner tube 10 mm wide, 2 rivets or 2 short bolts with nuts.

Instructions

Slit the rubber hose lengthwise. Rivet or bolt two loops of inner tube to each end of the hose. The loops should be long enough to slip over the axehead and hold the rubber hose in place covering the blade.

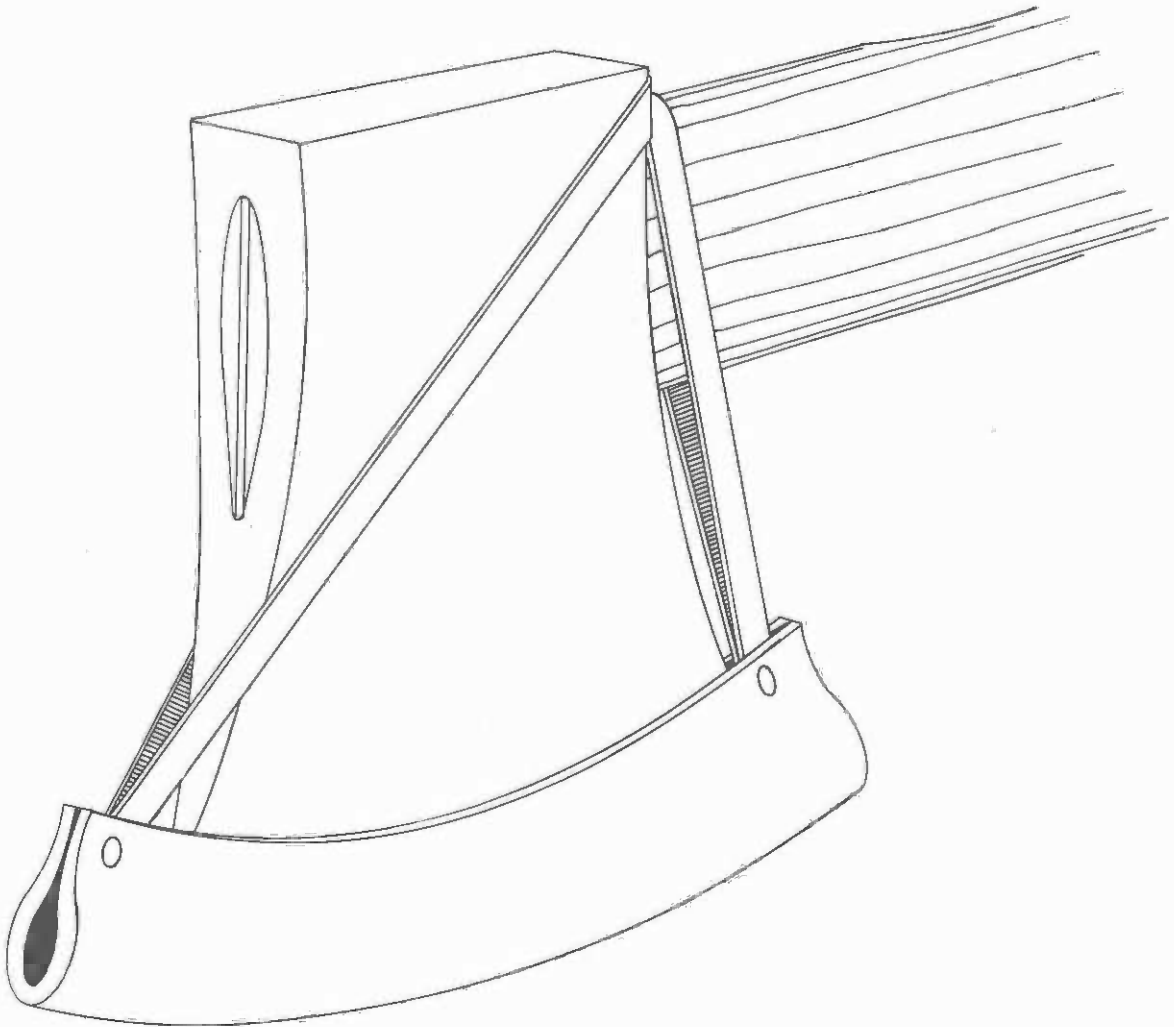

9. Wooden frame bowsaw

Use

To cut light wood.

Material

Use softwood or light hardwood. For the ends, 1 piece 110 x 70 x 800 mm and 1 piece 110 x 70 x 480 mm. For the crossbar, 1 piece 30 x 20 x 180 mm. Sawblade of 1 050 mm, 2 metal pins 6 mm Ø x 35 mm, a length of rope 3 mm Ø x 7 000 mm.

Instructions

Shape the ends and the crossbar as shown. Drill a hole in each end for the sawblade pins and attach the sawblade. Put the crossbar in place. Fold the rope double and loop it over the top of both ends. Push the tension arm through the strands of rope as shown, making sure that it overlaps the crossbar. Turn the tension arm slightly to the side and twist the rope until the blade is straight and tight. When the blade is tight, hook the end of the tension arm on the crossbar to keep it from turning.

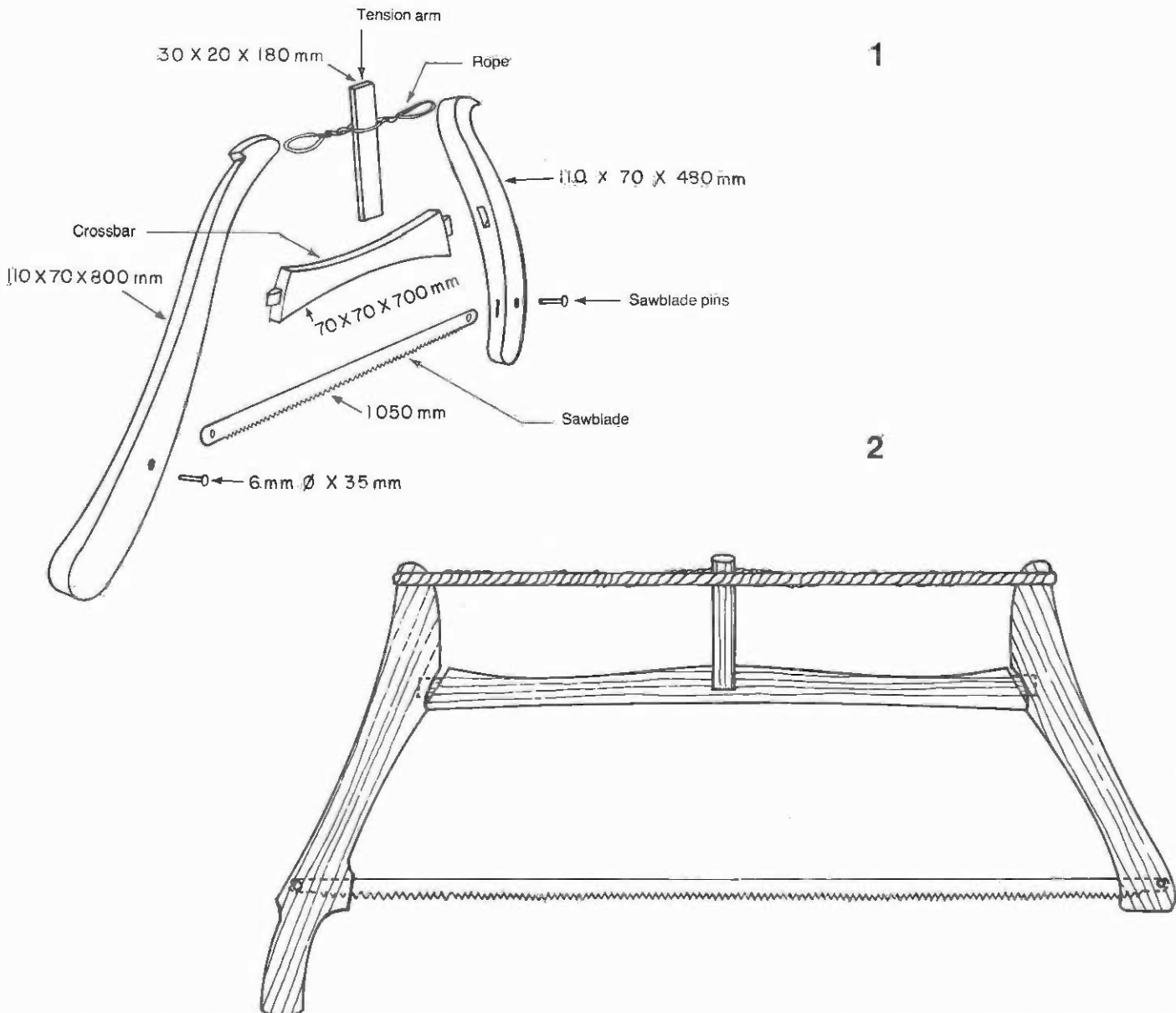

10. Stand for filing crosscut saws

Use

To hold a crosscut saw in place when filing the blade.

Material

A solid tree stump or a length of log driven into the ground, thin wooden wedges.

Instructions

Cut off a tree stump at elbow height or drive a length of log firmly into the ground to elbow height. Cut two slots in the top of the stump or log, one at an angle for filing cutting teeth and one vertical for jointing the blade and filing raker teeth. Insert the saw in the appropriate slot and hold it tightly in place with several thin wooden wedges. You can easily make this stand in the field.



11. Jointer for saws 1

Use

To accurately level the cutting teeth of saws.

Material

A block of hardwood 150 x 60 x 25 mm, a flat file for metal, thin wooden wedges.

Instructions

Saw a groove 10 mm deep and 3 mm wide the length of the wooden block. Slide the flat file into the groove. You may have to hold the file in place with thin wooden wedges. Hold the block against the face of the blade so that the file is flat and square against the top of the cutting teeth. Move the file back and forth over the teeth until they are level.

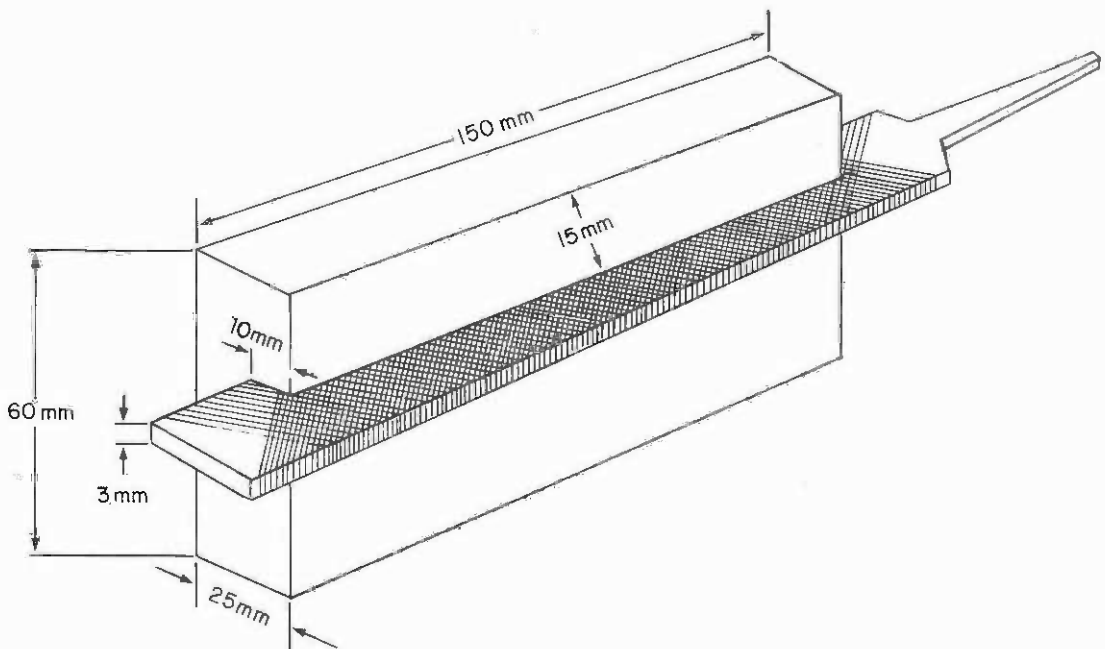

12. Jointer for saws 2

Use
To accurately level the cutting teeth of saws.

Material
1 piece of wood 200 x 50 x 5 mm for the top, 2 pieces of wood 200 x 30 x 24 mm for the sides, a flat file for metal.

Instructions
Cut a section 9 x 5 mm off the length of each of the sides for the file. Nail the top on to these as shown. Slide a flat file into this slot. Fit the blade into the 2 mm groove formed by the two sides so that the bottom of the file is flat and square against the top of the teeth. Move the file back and forth over the teeth until they are level.

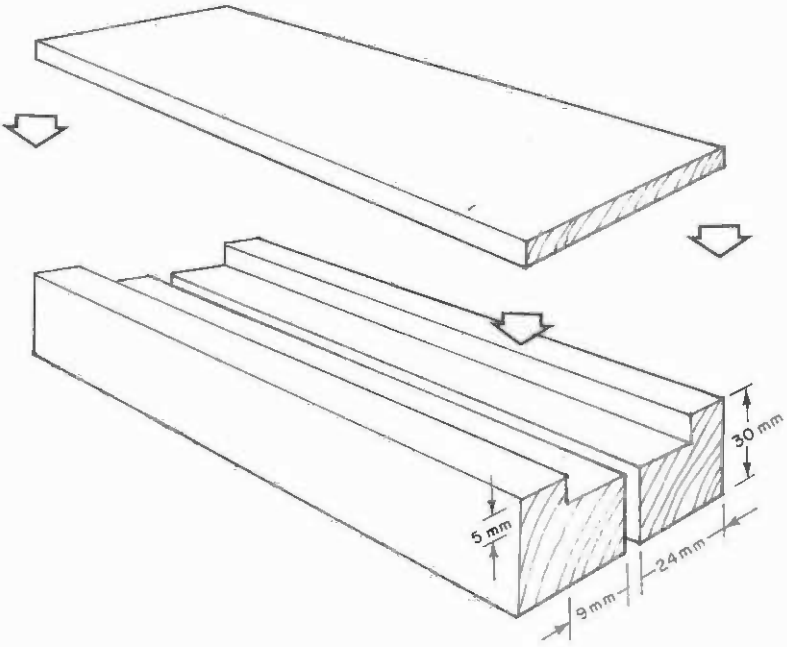
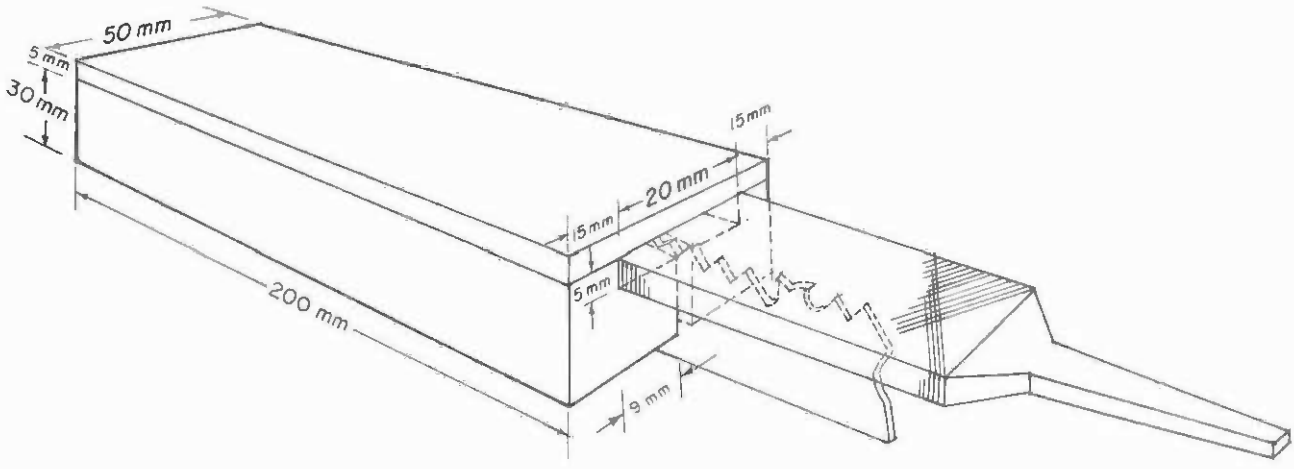

13. Saw set

Use

To set or bend the tips of alternating teeth of a saw.

Material

A piece of hard metal 150 x 20 x 4 mm.

Instructions

Shape the piece of metal to fit the hand. Drill four holes of 4 mm each in the metal and cut a slot into each hole to the measurements shown. Slip the slot that fits best over alternating cutting teeth and bend them out slightly, one tooth one way and one tooth the other way. The round hole at the end of the slot will protect the tip of each sawtooth as it is being bent.

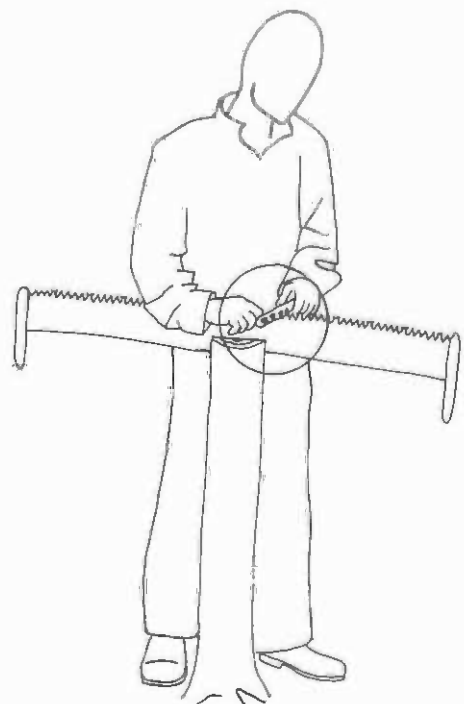
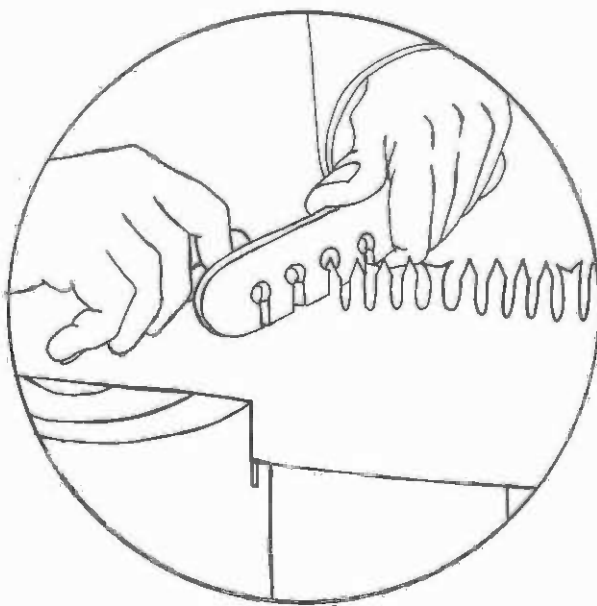
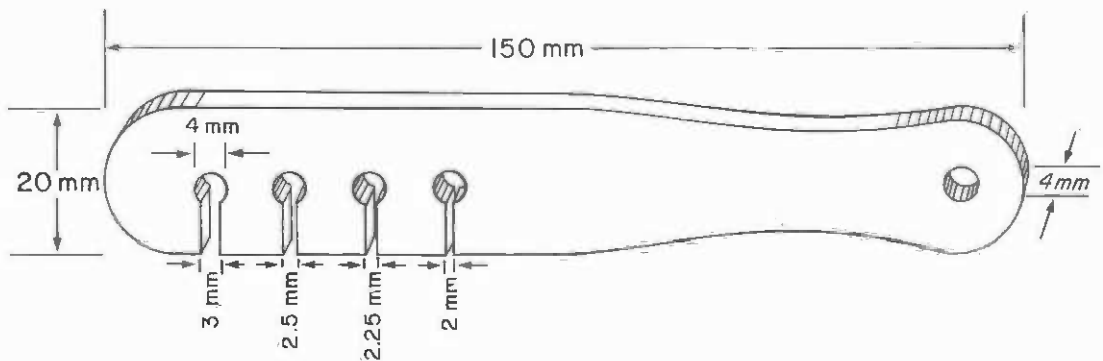

14. Set gauge

Use

To test that sawteeth are properly set.

Material

An oval piece of wood 40-60 x 10 mm, 4 nails.

Instructions

Drive the four nails into the wood in a diamond pattern. The upper nail must be shorter than the lower three nails. The table below shows the dimensions to use to set softwood and hardwood saws. When the gauge can be held against a tooth firmly with no back and forth movement, that tooth is properly set.

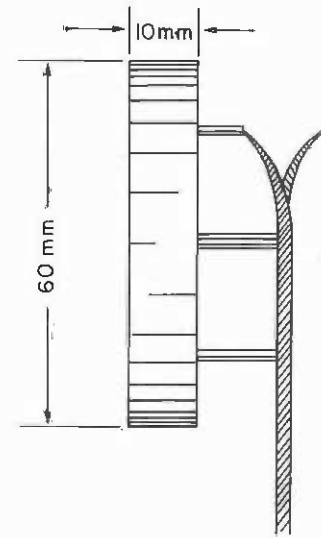
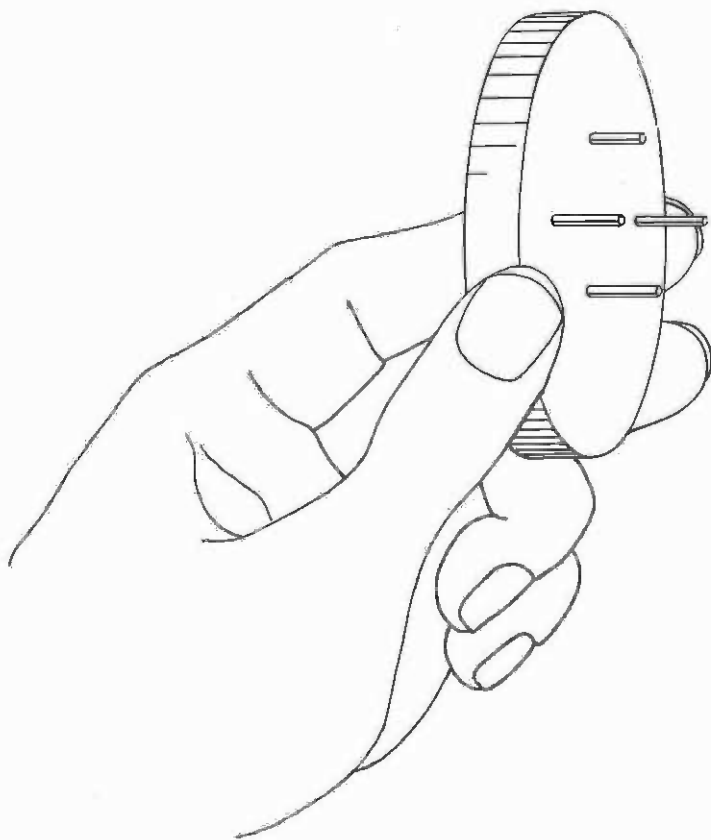

	Length of Protrusions	
	Upper nail	Lower nail
Softwood	0.3	0.6
Hardwood	0.2	0.4

15. Raker gauge

Use

To set the depth of raker teeth on a crosscut saw.

Material

A flat piece of metal 100 x 50 x 4 mm.

Instructions

Fold the piece of metal lengthwise to form a slot the thickness of a saw. Cut one or two sections out of the folded side of the metal. The diagram below shows the dimensions to use for softwood and hardwood saws. Slide the gauge along the blade and file each raker tooth to the proper height. Raker teeth are kept below the points of cutting teeth.

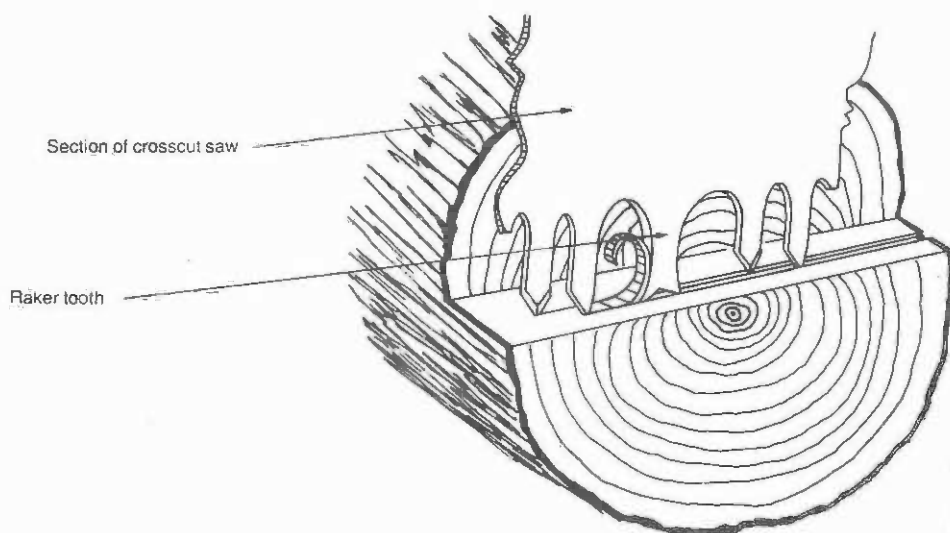
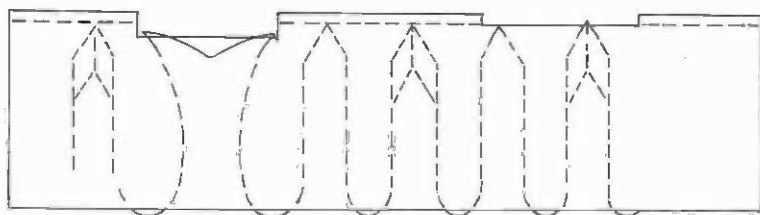
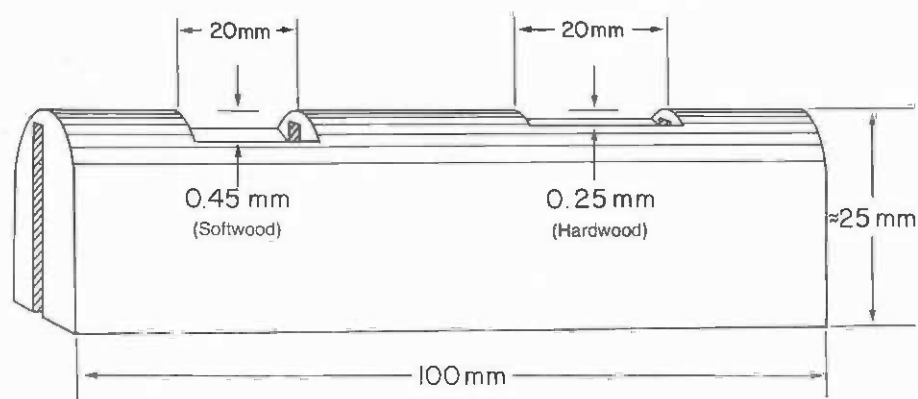

16. Sawblade guard

Use

To cover a sawblade not in use.

Material

A piece of rubber hose about 1 000 mm long.

Instructions

Cut the hose to the proper length. Unfasten the sawblade at one end, slide the hose over the blade and fasten the blade to the frame again.

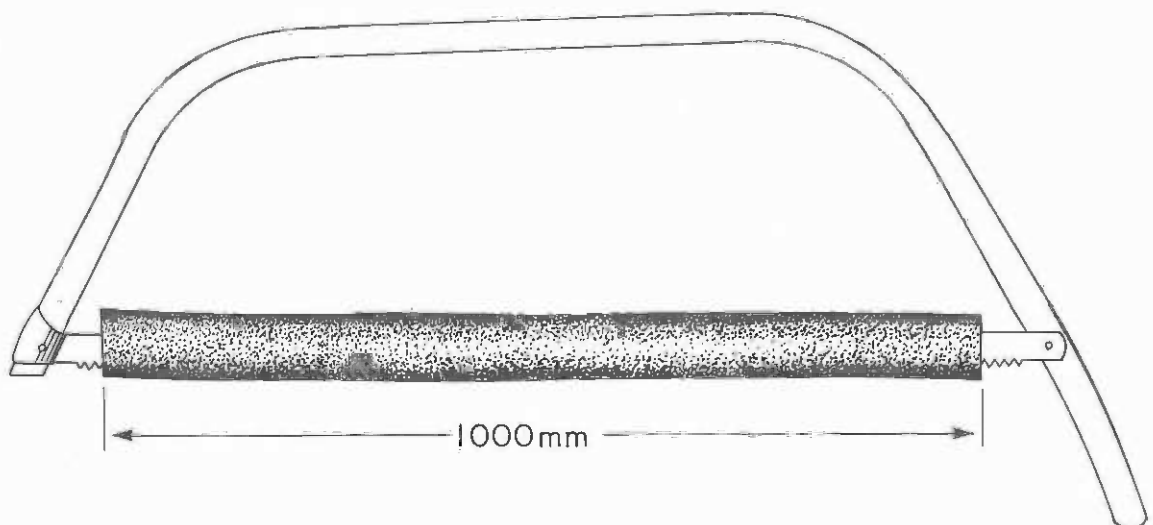

17. Log jack 1

Use

To raise the end of a log above the ground for cutting.

Material

A cant hook, an iron bar 500 x 50 x 10 mm.

Instructions

This tool is made by adapting a standard cant hook. Cut two small pieces about 50 x 50 mm from the end of the iron bar. Shape the remaining piece of the bar as shown. Cut a rounded notch in the top of the small pieces and the upright at the back of the bar so that they fit the underside of the cant hook. Weld all of the pieces to the cant hook as shown. The log jack should be strong enough to lift heavy logs and hold them at least 15 cm above the ground.

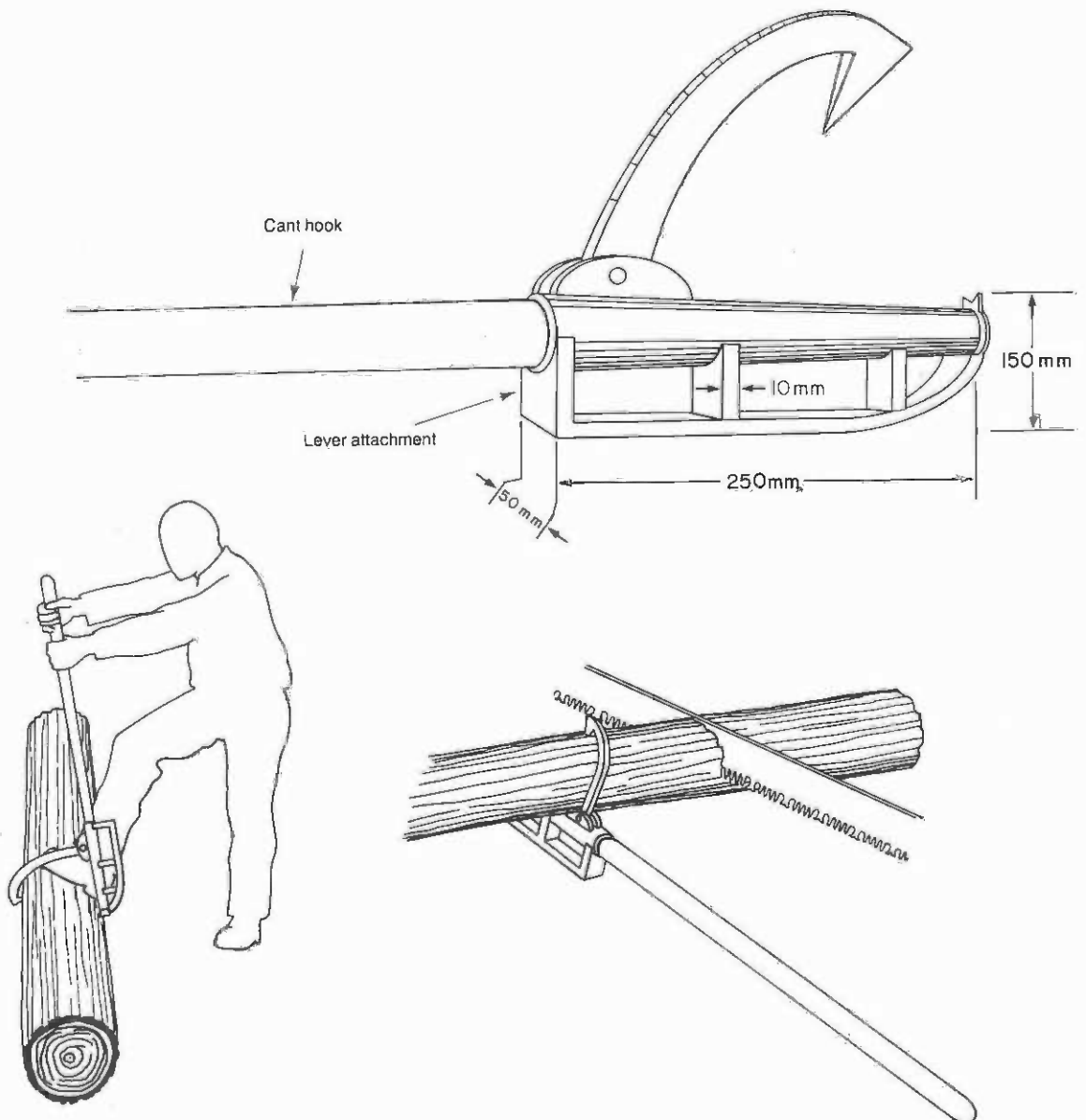

18. Log jack 2

Use

To raise the end of a log above the ground for cutting.

Material

A cant hook, 1 piece of 40 x 40 mm angle iron 350 mm long and 5 mm thick, 1 piece of 40 x 40 mm angle iron 250 mm long and 5 mm thick, 1 piece of pipe 40 mm Ø x 250 mm, 3 bolts 10 mm Ø x 50 mm with washers and nuts.

Instructions

This tool is made by adapting a standard cant hook. As shown in the diagram, cut and shape the longer piece of angle iron (1), weld a flange to the top of the pipe (2) and drill holes in the three metal pieces and the cant hook. Bolt the pieces together (3). A log jack should be strong enough to lift heavy logs and hold them at least 15 cm above the ground.

Note

The advantage of this log jack over Log Jack 1 is that by removing two bolts, it can be used as a cant hook as well.

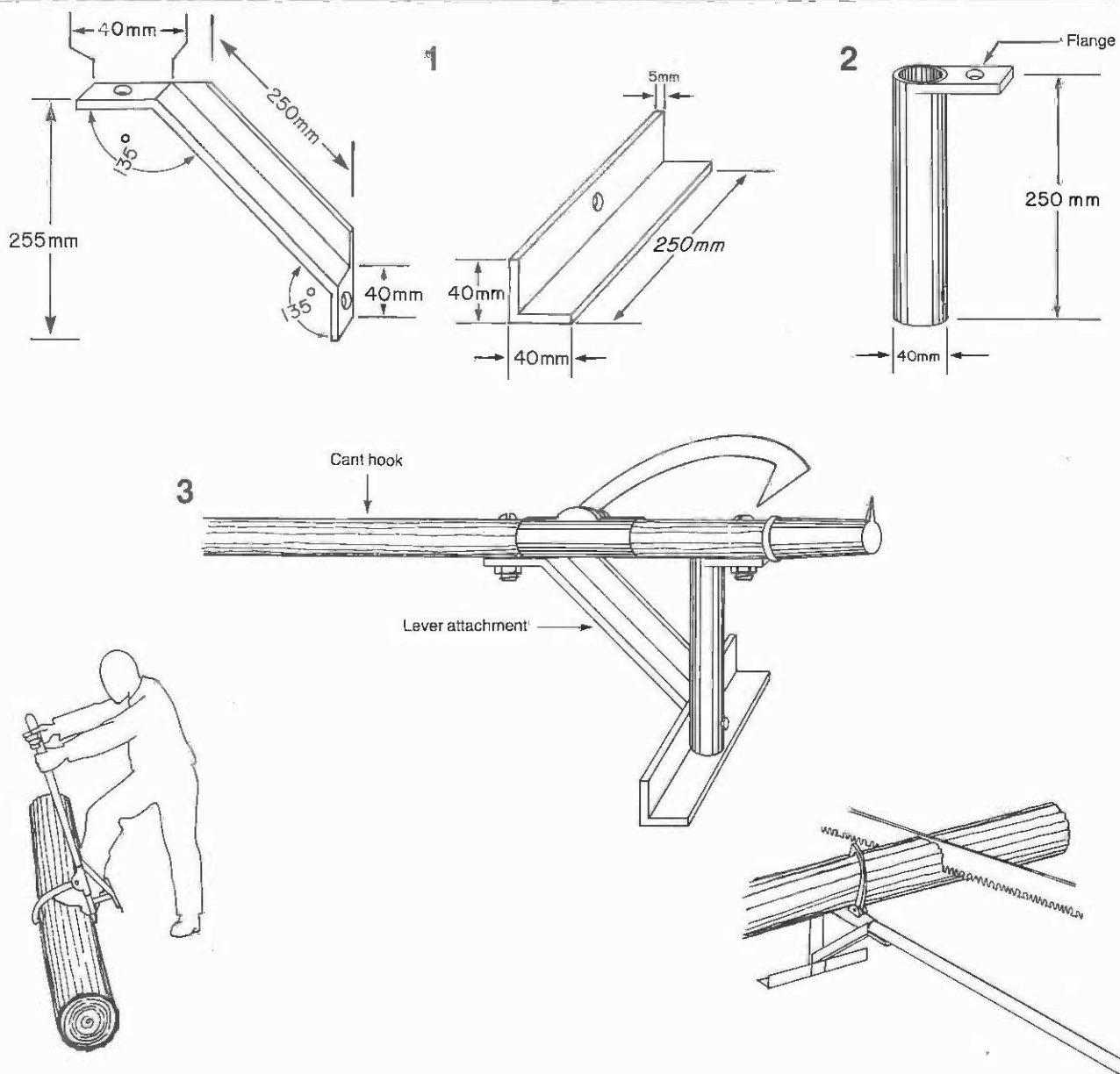

19. Log jack 3

Use

To raise the end of a log above the ground for cutting.

Material

A length of pipe 35 mm \varnothing x 400 mm with a 3 mm thick wall, 1 piece of 40 x 40 mm angle iron 120 x 5 mm, a triangular piece of steel 30 x 30 x 5 mm, 2 square pieces of iron 40 x 40 x 5 mm, 1 flat iron bar 500 x 20 x 7 mm, 1 bolt 10 mm \varnothing x 40 mm with washers and nut, 1 round wooden handle 30 mm \varnothing of convenient length.

Instructions

Bend the length of pipe (1) as shown, and weld the angle iron on to the lower end (2). Weld the triangular piece of steel (3) on the outside bend of the pipe. Weld on the two square pieces of iron 10 mm apart near the upper end of the pipe (4). Shape the flat iron bar into a hook (5). The point of the hook should be sharpened and hardened. Drill a hole through the metal squares and the hook (4) in such a way that the hook will be free to move. Bolt the hook in place. Insert the round wooden handle in the pipe. A log jack should be strong enough to lift heavy logs and hold them at least 15 cm above the ground.

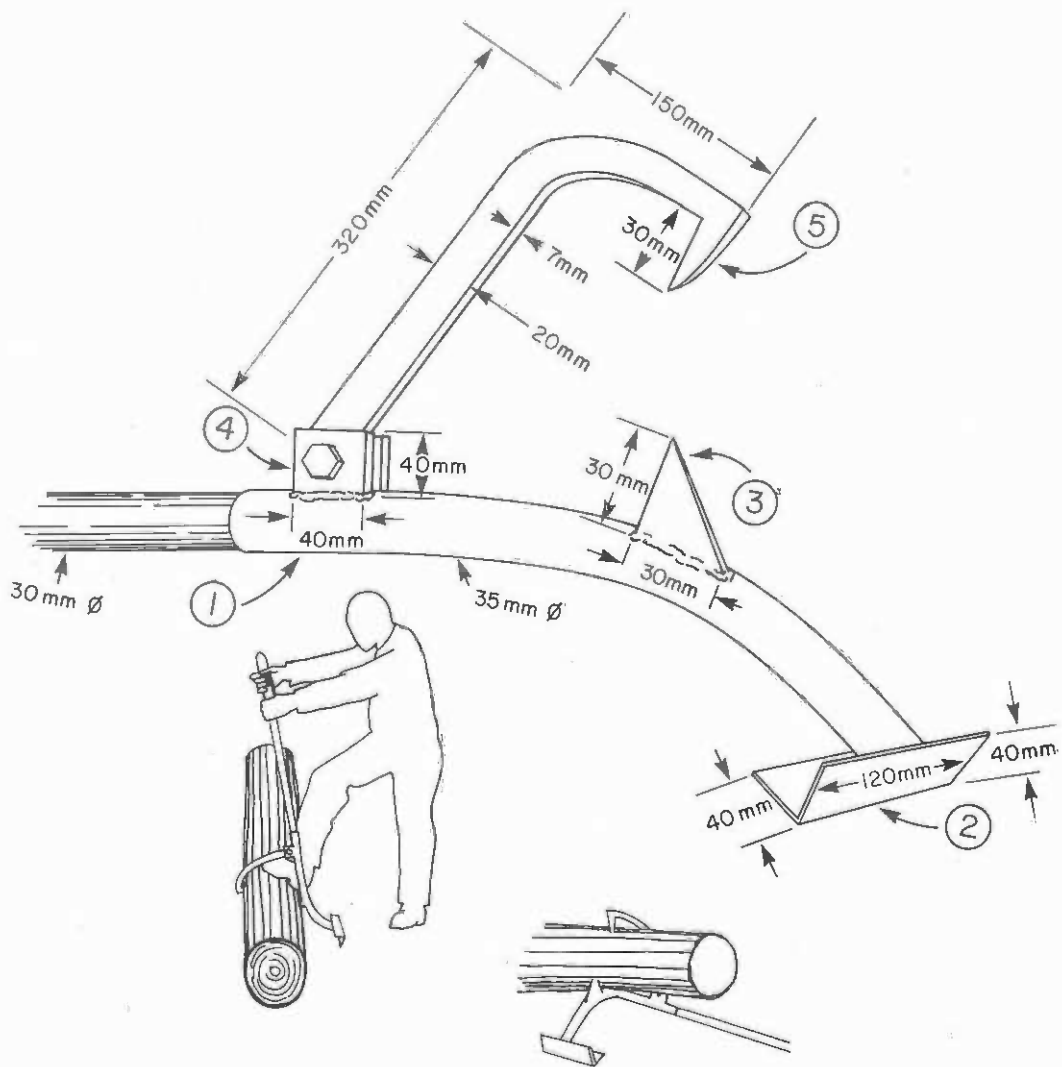

20. Sawhorse 1

Use

To hold short or long logs level and off the ground for sawing.

Material

1 log 90 mm \varnothing x 1 000 mm, 2 pieces of wood 50 mm \varnothing x 550 mm, 1 short piece of wood 30 mm \varnothing x 140 mm, 2 small wedges.

Instructions

Drill or cut two holes through the log and drive in the legs as shown. Legs are held fast with the wedges. When in place the legs should form an angle of about 80°. Drill or cut another hole in the log for the short piece of wood. This is to hold a log in position for cutting. Two sawhorses are used to saw the logs.

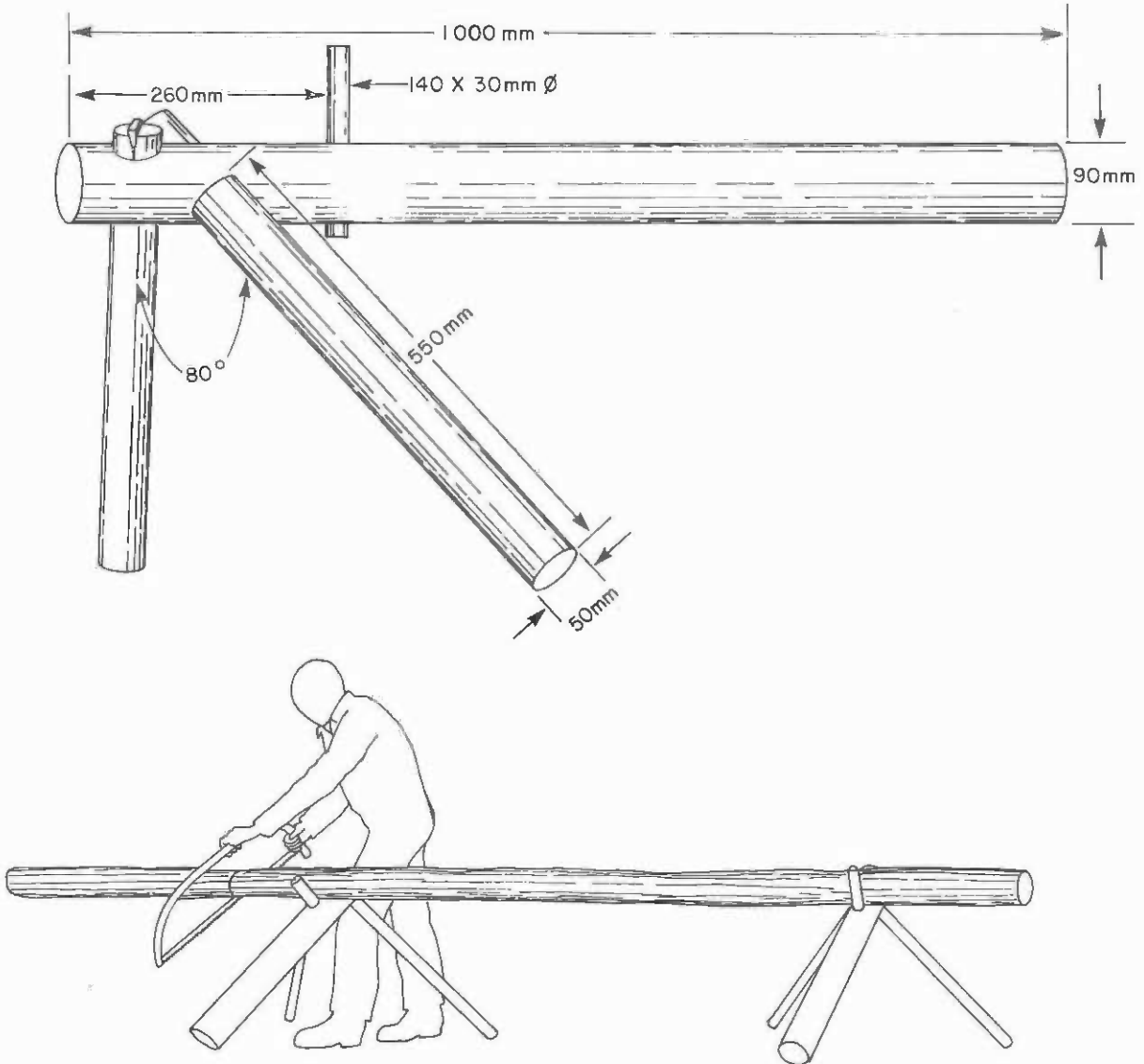

21. Sawhorse 2

Use

To hold short or long logs level and off the ground for sawing.

Material

2 pieces of wood 900 x 100 x 100 mm, 1 pole 60 mm \varnothing x 2000 mm.

Instructions

Cut a notch in the two pieces of wood so that they will fit together to form an X-piece. The upper part of the X should be shorter (300 mm) than the bottom part (600 mm). Drill a hole where the pieces of wood are joined and drive in the pole. Two sawhorses are used.

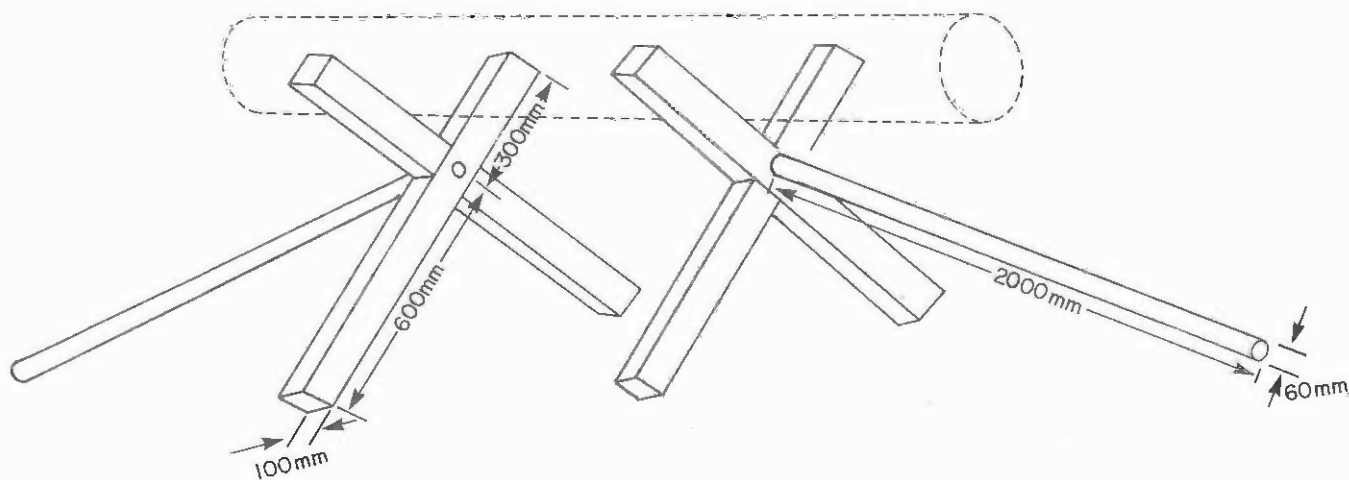

22. Sawhorse 3

Use
To hold a short log level and off the ground for sawing.

Material
4 pieces of cut lumber 1 000 x 100 x 50 mm, 2 pieces of cut lumber 1500 x 100 x 50 mm, a short length of chain with a stirrup or 4 pieces of old sawblade, nails.

Instructions
Nail the four short pieces of lumber together to form two X-pieces. Cut the top and bottom of each X so that they will be parallel to the ground. Join the X-pieces by nailing the two long pieces of lumber to the lower part of each X as shown. A log can be held in place in this sawhorse with a short length of chain and a stirrup or with four short pieces of old sawblade nailed to the upper part of each X. Only one sawhorse is needed.

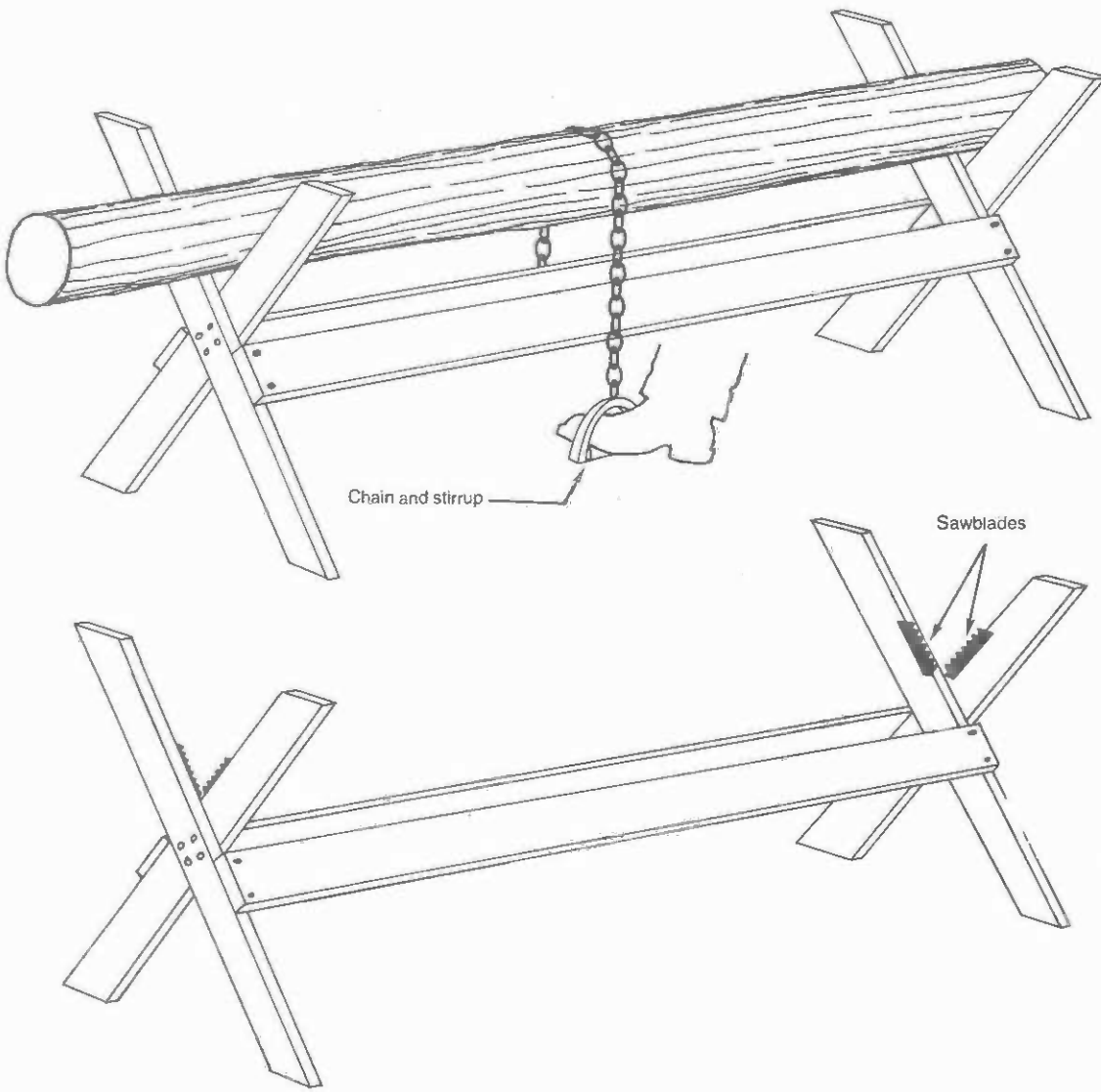

23. Wooden wedges

Use

To direct trees when felling. To assist in splitting logs along the grain.

Material

Dense hardwood or, when available, metal or plastic.

Instructions

Cut wedges for various functions using the dimensions shown below.

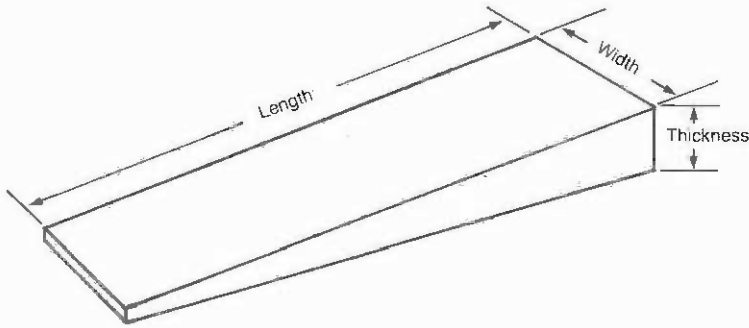

Wedge profiles



Concave – wedge drives in part way and then pops loose



Straight – makes good contact and stays in place



Convex – only makes contact with leading half and often works loose

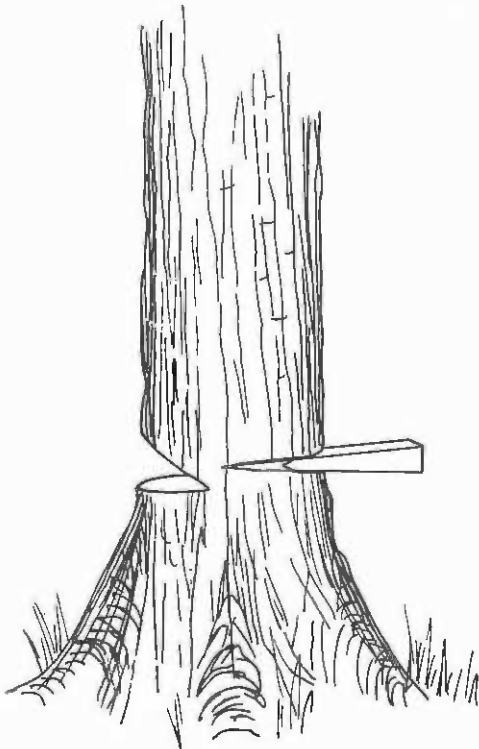

Application	Thickness	Width	Length
Felling	20-30 mm	50-70 mm	200-280 mm
Crosscutting	20 mm	40-60 mm	100-120 mm
Splitting (normal)	30-50 mm	40-60 mm	200-280 mm
Splitting (large)	80-100 mm	100-120 mm	300-350 mm

24. Control for trees felled on slopes

Use

To stop a felled tree from sliding downhill on a steep slope.

Material

A short length of wire cable 10-20 mm Ø, 4 cable clamps for the size of cable to be used.

Instructions

Make the undercut (1). Pass the ends of the cable around the tree and clamp one end below the undercut and the other end of the cable far enough above to make the felling cut below it (2). Both clamps should be fastened on the downhill side of the tree as shown. When the felling cut is made, the cable will keep the tree from sliding down (3).

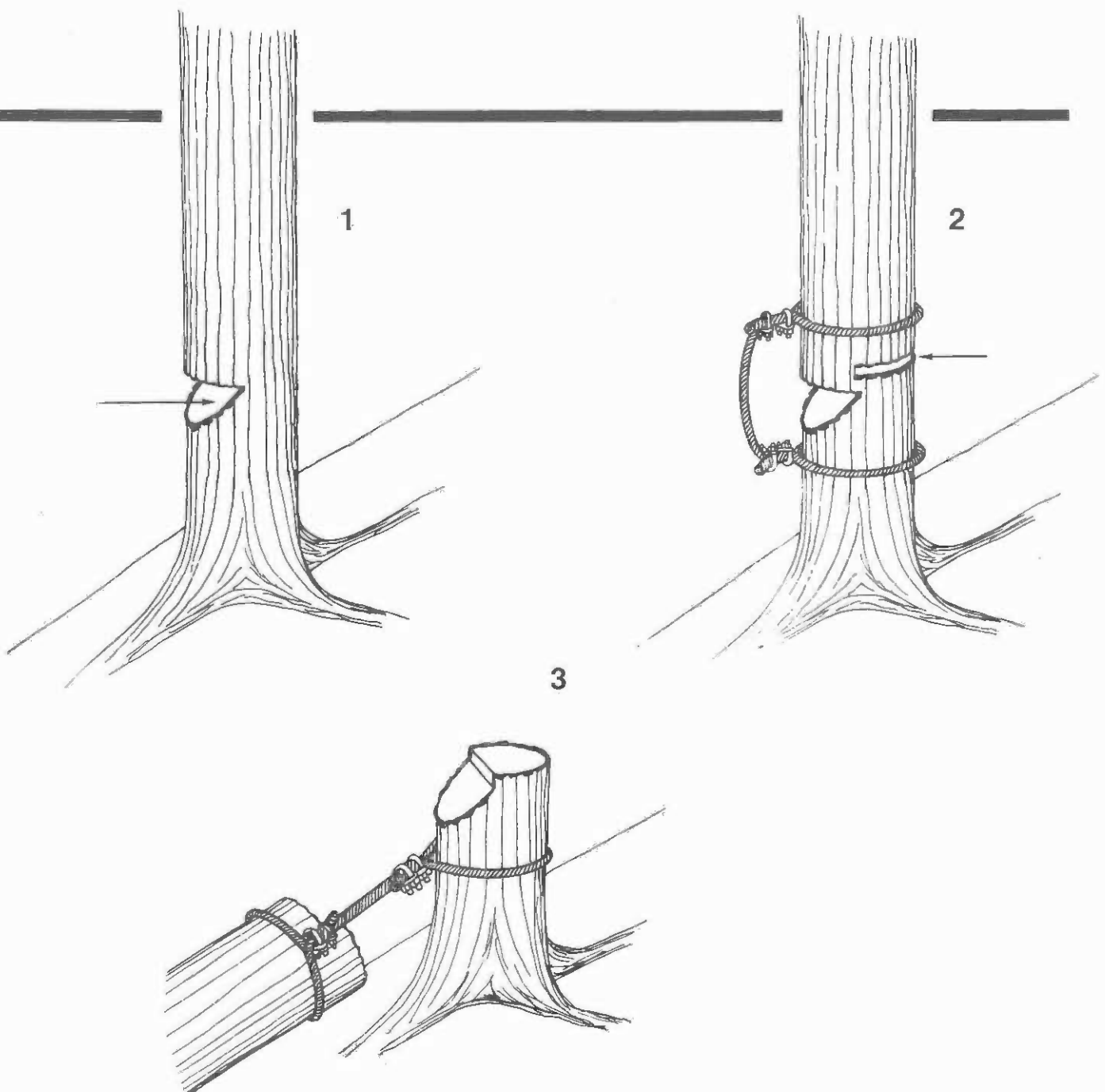

DESIGN MANUAL ON BASIC WOOD HARVESTING TECHNOLOGY

BOOKLET 2

MOVING AND CARRYING HEAVY LOADS BY HAND

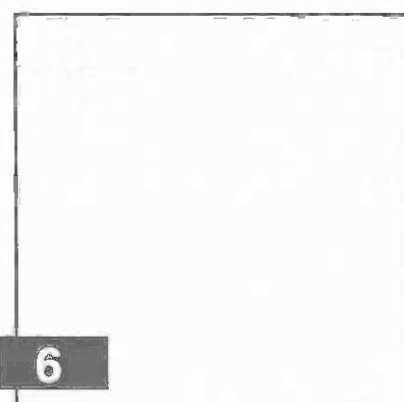
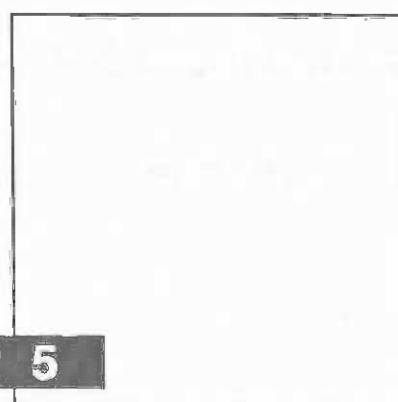
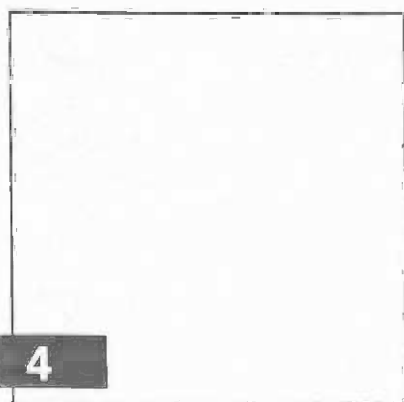
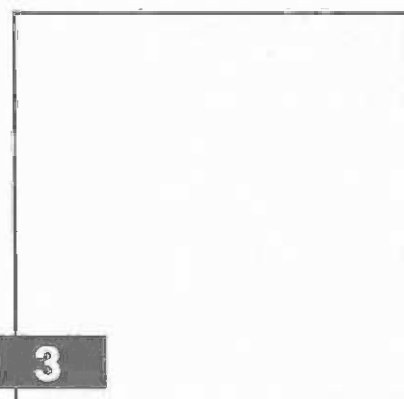
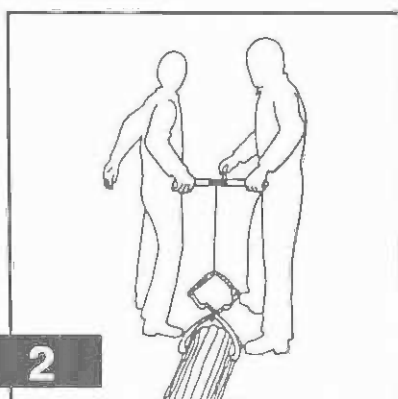
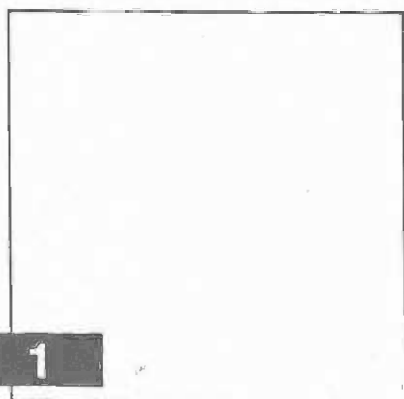

The designations employed and the presentation of material in this publication do not imply the expression of any opinion whatsoever on the part of the Food and Agriculture Organization of the United Nations concerning the legal status of any country, territory, city or area or of its authorities, or concerning the delimitation of its frontiers or boundaries.

M-39
ISBN 92-5-102537-1

All rights reserved. No part of this publication may be reproduced, stored in a retrieval system, or transmitted in any form or by any means, electronic, mechanical, photocopying or otherwise, without the prior permission of the copyright owner. Applications for such permission, with a statement of the purpose and extent of the reproduction, should be addressed to the Director, Publications Division, Food and Agriculture Organization of the United Nations, Via delle Terme di Caracalla, 00100 Rome, Italy.

© FAO 1989

Contents

1. Backrack
2. Yoke 1
3. Yoke 2
4. Log tongs 1
5. Log tongs 2
6. Wheelbarrow 1
7. Wheelbarrow 2
8. Wheelbarrow 3
9. Wheelbarrow 4
10. Lever logging cart
11. Hand sulky
12. Using a hand sulky
13. Using a sulky on steep slopes 1
14. Using a sulky on steep slopes 2
15. Rolling logs by hand
16. Wooden chute
17. Metal chute
18. Log sledge
19. Narrow-gauge track
20. Pole track

Symbols and abbreviations used

°	Degree (angle)	
∅	Diameter measurement	
kg	Kilogram	= 2.205 pounds (lb)
m	Metre	= 1.094 yards (yd)
mm	Millimetre	= 0.0394 inch (in)
%	Percentage	

Note

Additional valuable information on the kinds of tools shown in this booklet can be found in FAO Forestry Paper 36, *Basic Technology in Forest Operations* (ISBN 92-5-101260-1).

1. Backrack

Use

To carry firewood and short logs.

Material

4 pieces of wood 700 x 50 x 25 mm, 3 pieces of wood 350 x 50 x 25 mm, 2 metal angles, 2 leather bands 400 x 100 and 2 leather straps 500 x 50 mm at least 3 mm thick, screws and nails.

Instructions

Assemble the two wooden frames of the backrack. Attach the front to the back, leaving an opening of 400 mm at the top, using the metal angles as shown in the detail. Nail the leather bands and straps to the frame so that loads are comfortable to carry.

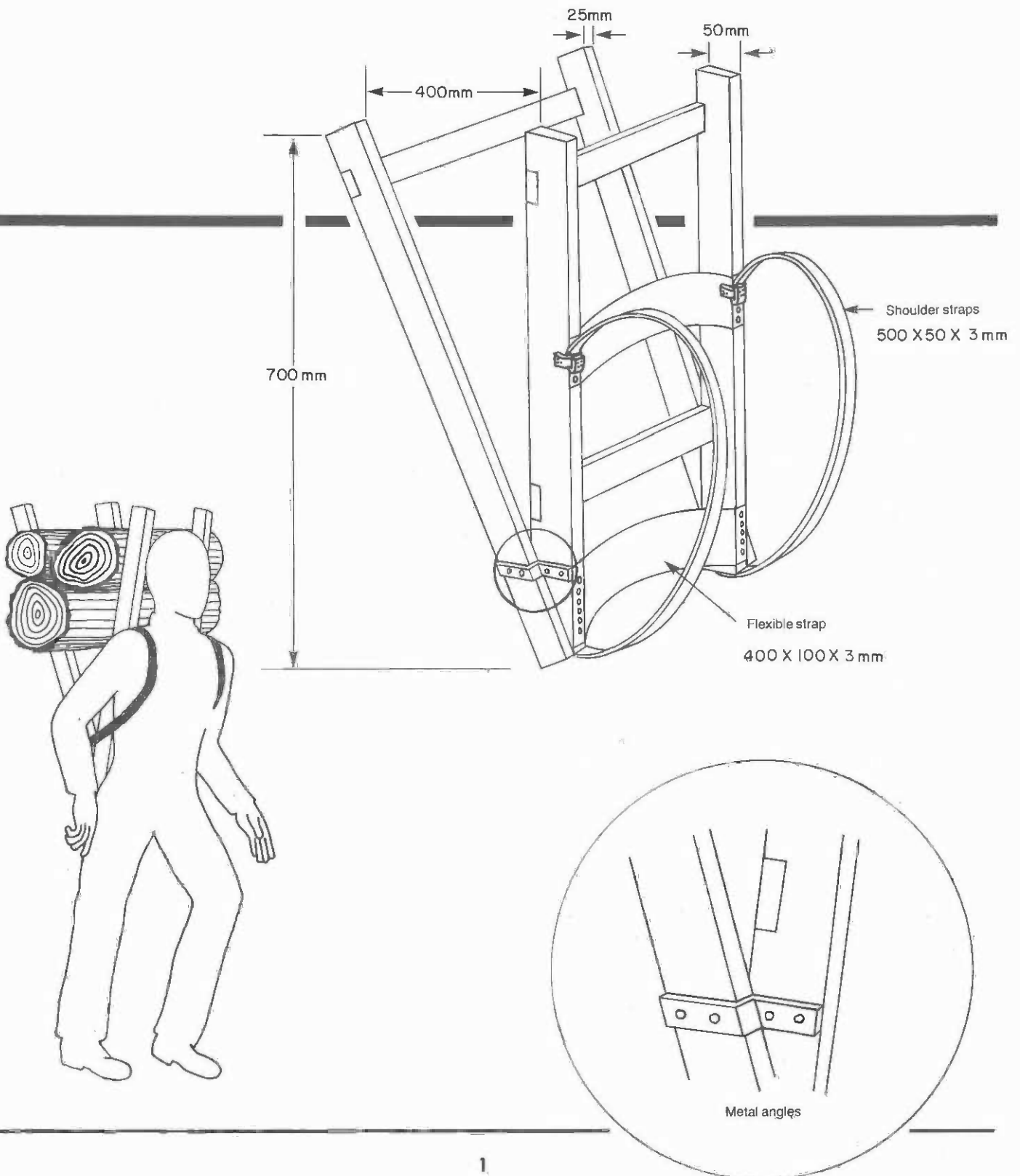

2. Yoke 1

Use

To carry firewood and short logs.

Material

1 piece of hardwood 170-200 mm Ø x 950 mm, short lengths of rope, wire or chain, 2 hooks.

Instructions

Shape the yoke following the diagram. First saw the basic shape and then carve with a knife. Drill a hole in each end of the yoke. Thread a rope, wire or chain through each hole, adjust the length according to the height of the user and attach a hook to the bottom of each. The wood to be carried is stacked in loose loops of rope and hung from the hooks.

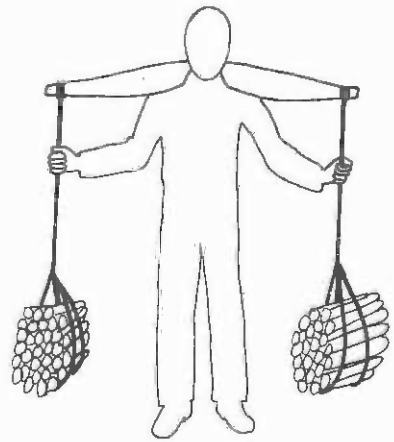
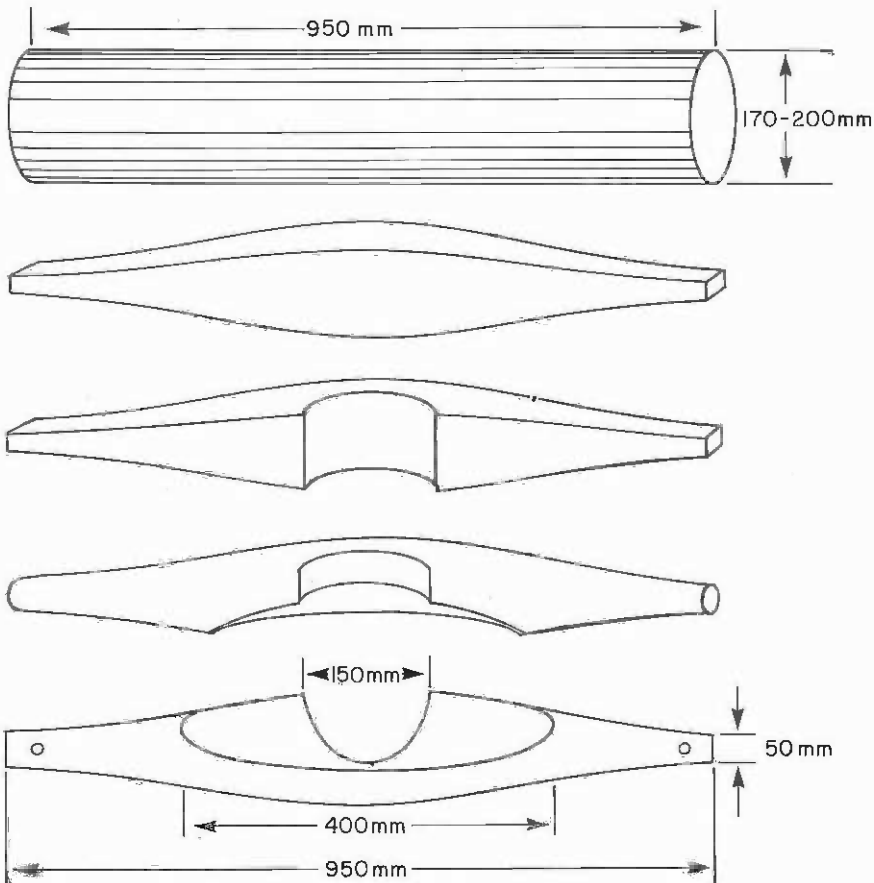

3. Yoke 2

Use

To carry firewood and short logs.

Material

2 long poles 50 mm Ø x 2000 mm, 2 short poles 50 mm Ø x 400 mm, 2 flexible straps 600 x at least 50 mm, heavy cord, a length of rope.

Instructions

Lash the long poles together at the ends using heavy cord. Pull these poles apart at the middle and lash the short poles in place as shown. Attach the shoulder straps to the long poles (1) or the short poles (2) according to the way the yoke is to be used. The wood to be carried is stacked in loose loops of rope hanging from the ends of the yoke.

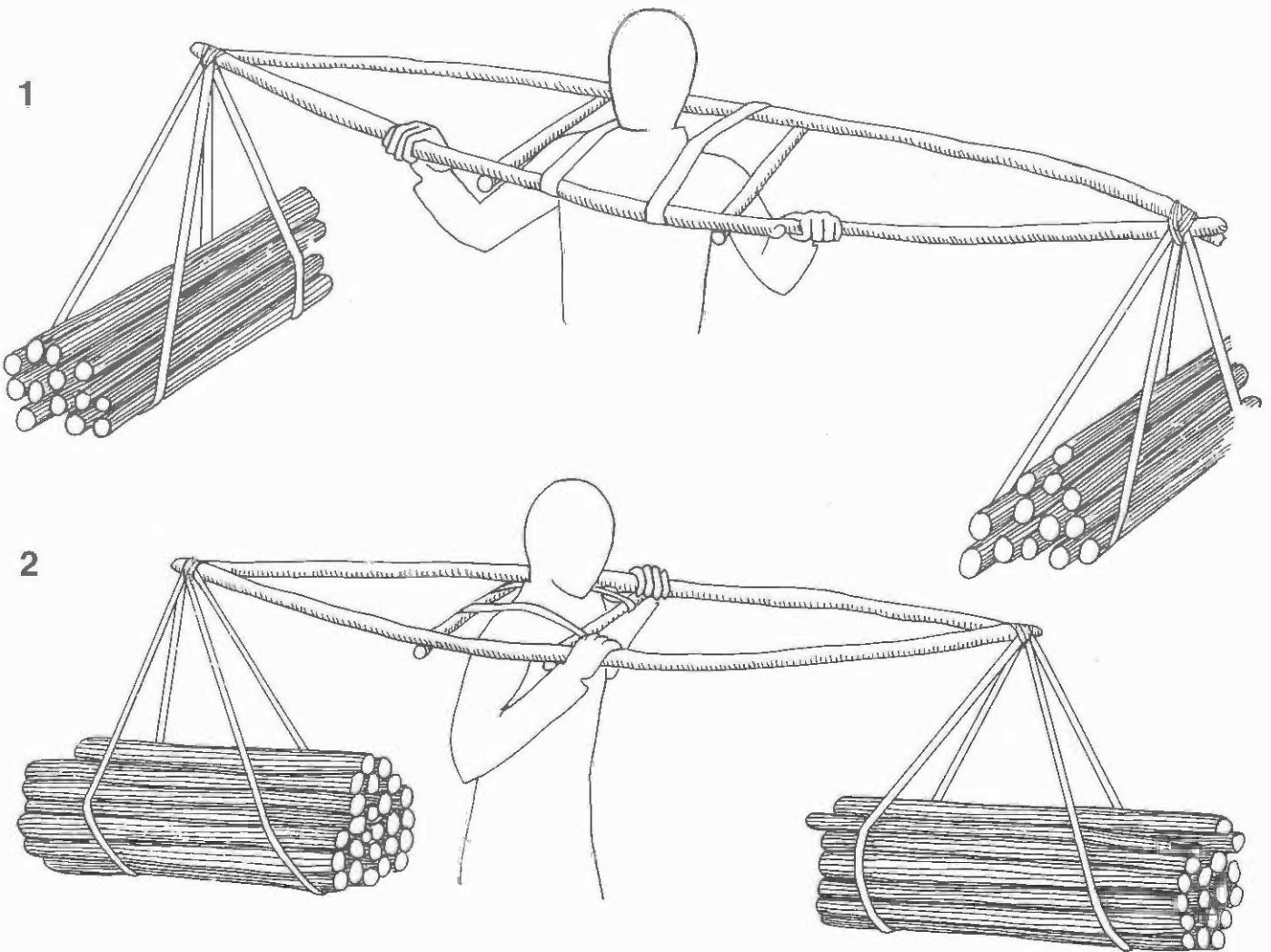

4. Log tongs 1

Use

To drag and lift logs.

Material

2 iron bars 15 x 25 x 600 mm, 1 iron bar 15 x 25 x 110 mm,
1 rivet 10 mm Ø x 70 mm, a length of rope, 1 round piece
of wood 50 mm Ø x 700 mm.

Instructions

Heat and bend the long iron bars to form the tong arms (1). Each arm should have an eye at one end and a point at the other. Various kinds of points are shown below. Sharpen and harden the points. Heat and bend the short bar into a U-shape (2). Drill a hole through both arms and both sides of the U-shape and rivet them together (3). Attach the length of rope to the eyes in both tong arms (4). With these tongs one person can drag a log. An additional length of rope and a handle will allow two people to drag a log (5).

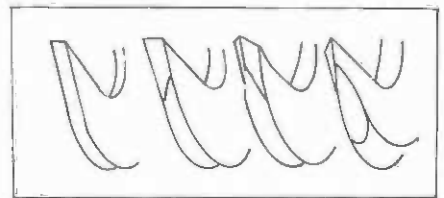
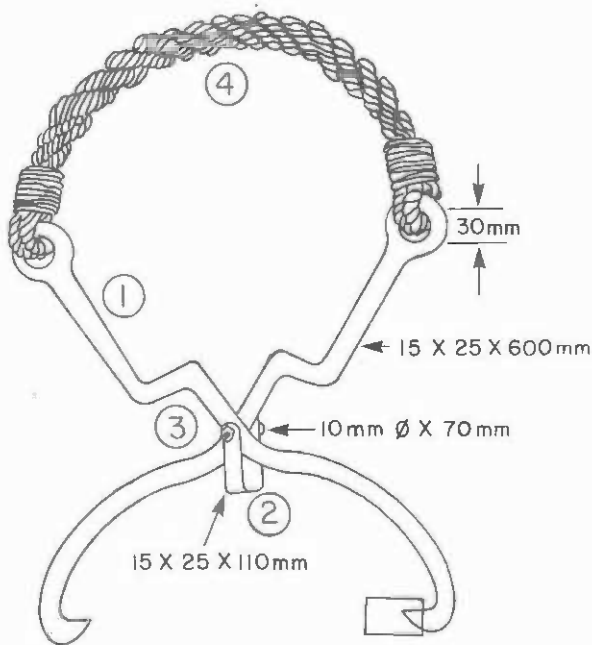

Different points for log tongs

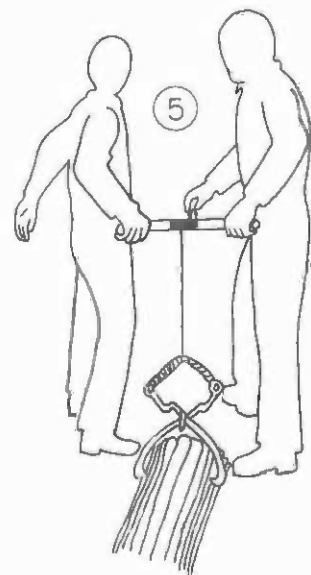

5. Log tongs 2

Use
To drag and lift logs.

Material
2 iron bars 340 x 25 x 15 mm, 1 rivet 10 mm Ø x 40 mm,
2 rings 50 mm Ø and 1 ring 100 mm Ø made from iron
rods 6 mm Ø and 9 mm Ø each, a length of rope, 1 round
piece of wood 50 mm Ø x 700 mm.

Instructions
Heat and bend the iron bars to form the tong arms. Each
arm should have a hole at one end and a point at the
other. Various kinds of points are shown below. Sharpen
and harden the points. Drill a hole through both tong
arms and rivet them together. Shape the small rings and
fit them into the holes in the tong arms. Shape the large
ring and fit it into the small rings. Attach the rope to
the round wood handle and to the large ring to allow two
people to drag a log.

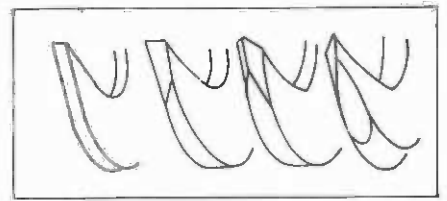
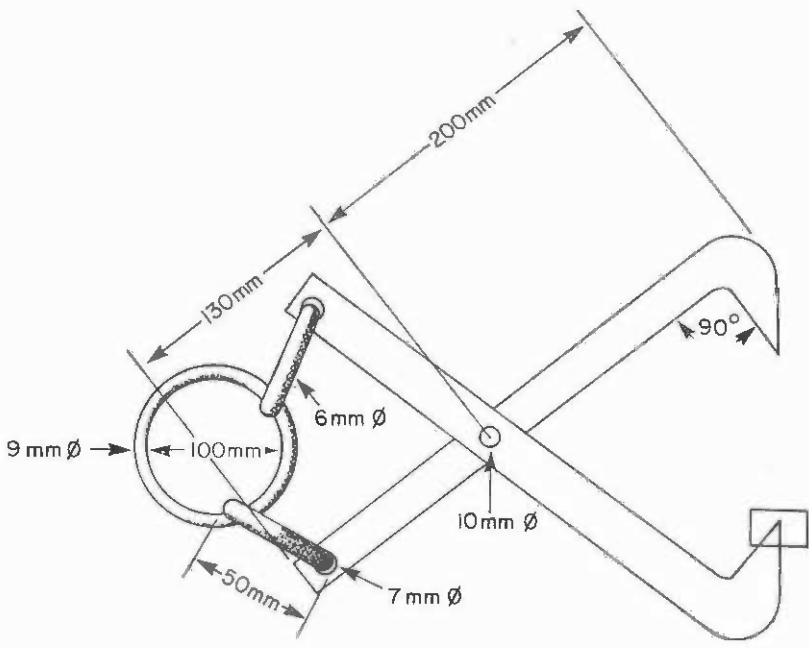

Different points for log tongs

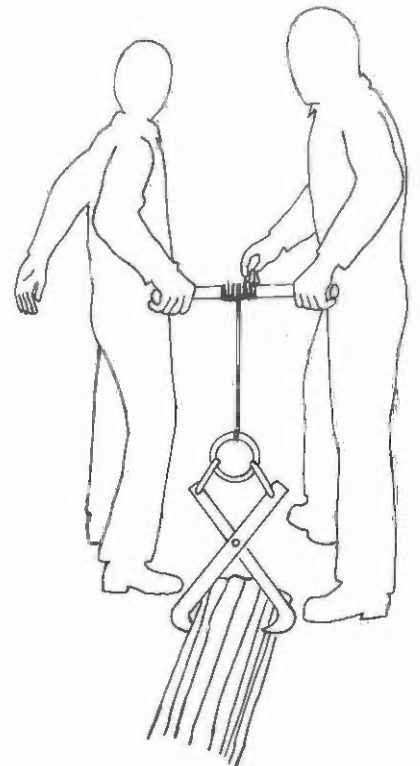

6. Wheelbarrow 1

Use

To move short logs or other materials.

Material

1 used oil drum, 2 pieces of pipe 30 mm Ø x 1 700 mm, 2 pieces of pipe 30 mm Ø x 600 mm, 2 pieces of pipe 30 mm Ø x 400 mm, 6 bolts 10 mm Ø with washers, 4 pieces of metal 50 x 50 x 5 mm, 1 wheel and axle.

Instructions

Cut the oil drum in two (1). Shape the long pipes for the frame of the wheelbarrow. Flatten one end of each frame-pipe and drill a hole in each suitable for the axle and wheel to be used. Assemble axle, wheel and frame-pipes. Drill holes in the drum, legs and leg braces and bolt them together as shown. The drum, legs and leg braces may also be welded together.

1

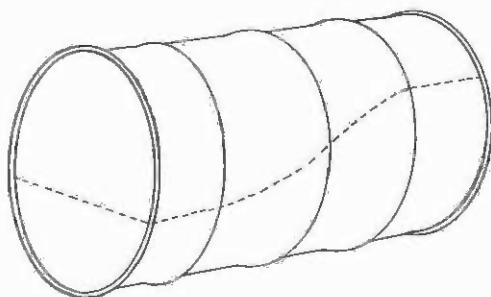

2

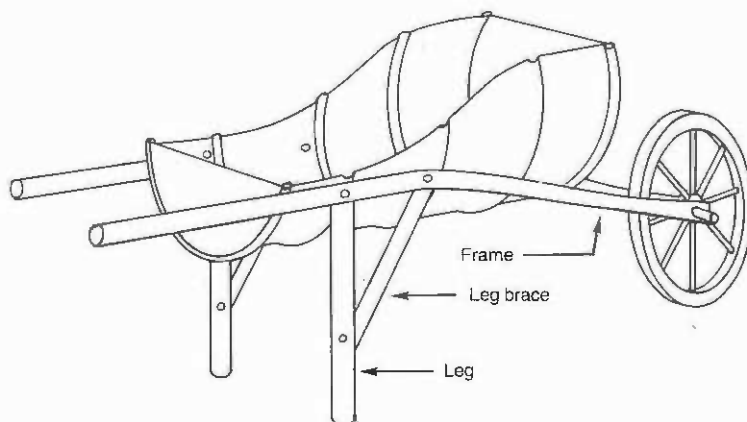

7. Wheelbarrow 2

Use

To move short logs.

Material

1 piece of pipe 25 mm \varnothing x 4 000 mm, 1 piece of pipe 25 mm \varnothing x 450 mm, 4 pieces of pipe 25 mm \varnothing x 400 mm, 2 pieces of flat iron 80 x 80 x 5 mm, 1 wheel and axle.

Instructions

Bend the long piece of pipe at the centre to form the frame. Weld the 450-mm pipe between the sides of the frame. The handles of the wheelbarrow should then be about 500 mm apart. For the legs weld on two of the 400-mm pipes below the curve of the handle. Weld on the remaining two 400-mm pipes to make the posts to hold the load. Cut the two small iron squares diagonally and weld them to the frame as shown to strengthen the connections. Fit the wheel and axle in place using hardwood blocks or metal bearings.

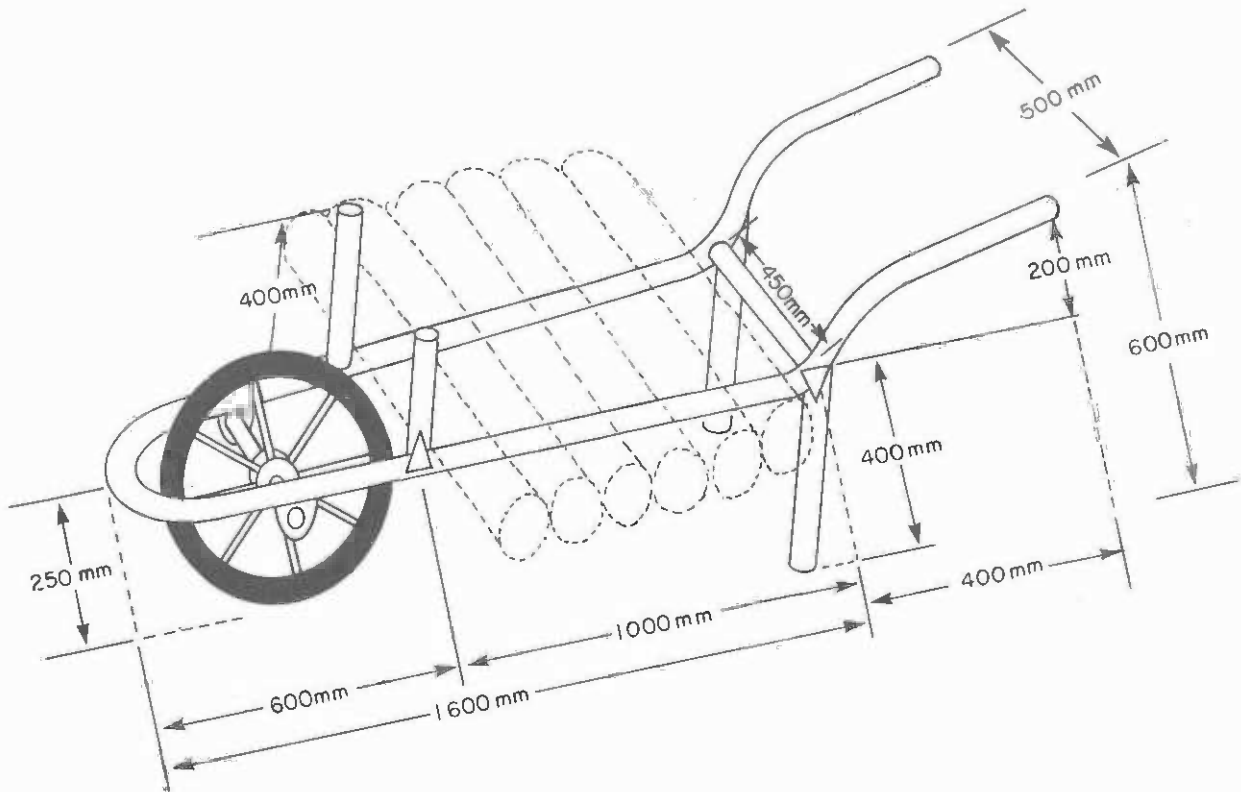

8. Wheelbarrow 3

Use

To move short logs.

Material

2 pieces of hardwood 1 300 x 60 x 30 mm (1), 2 pieces of hardwood 600 x 60 x 30 mm (2), 2 pieces of hardwood 1 700 mm x 60 x 30 mm (3), 2 pieces of hardwood 450 x 60 x 30 mm (4), 4 round pieces of hardwood 30 mm Ø x 450 mm (5), 1 wheel and axle (6).

Instructions

Shape handles of one end of the two long pieces of wood and drill a hole for the wheel and axle of the other end. Drill or cut holes for the remaining pieces of wood. Assemble all pieces following the illustration. Fit the wheel and axle in place using hardwood blocks. The larger the wheel diameter, the less effort is needed to push the wheelbarrow over rough ground.

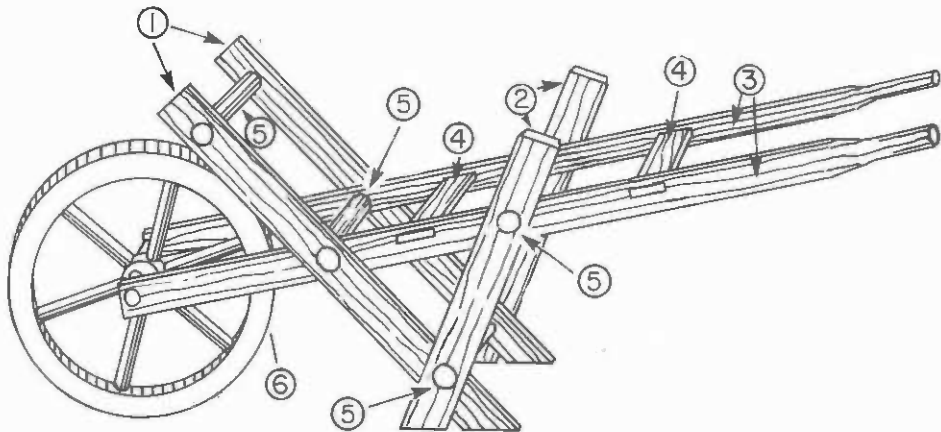

9. Wheelbarrow 4

Use

To move short logs.

Material

Sawn lumber: 2 pieces 100 x 30 x 2 000 mm long (1), 10 boards 200 x 20 x 1 000 (2), 2 pieces 100 x 30 x 1 500 mm long (3), 1 piece 300 mm long (4), a wheel and axle (5), nails, spikes, bolts with nuts or screws.

Instructions

The wheelbarrow may be assembled following the diagram. The design may be changed to suit the need or the materials available. This kind of wheelbarrow can be used over soft ground on a plankway.

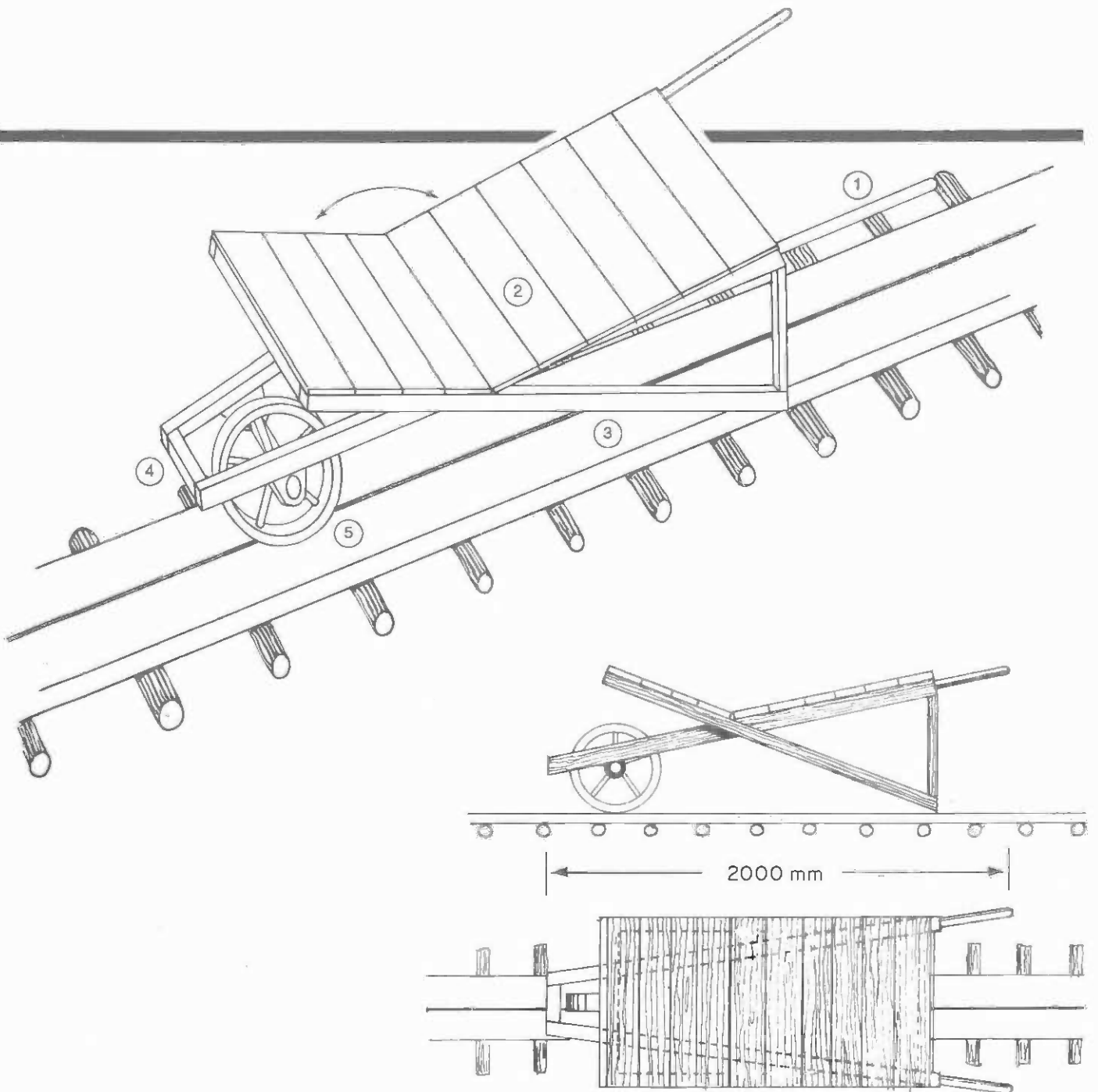

10. Lever logging cart

Use

To lift and move small logs.

Material

1 piece of pipe 40 mm \varnothing x 2 000 mm, 1 piece of pipe 40 mm \varnothing x 400 mm, 1 iron bar 80 x 15 x 5 mm, 2 used automobile wheels and an axle.

Instructions

Bend the long pipe so that the handle will be at waist height when the other end is about 200 mm off the ground. Weld the piece of pipe on for the handle. Heat and bend the iron bar, cut a V-notch in the end and weld it in place on the front end of the long pipe (see detail). Adjust the axle so the tires are about 400 mm apart and weld the axle to the underside of the pipe about 450 mm from the front end.

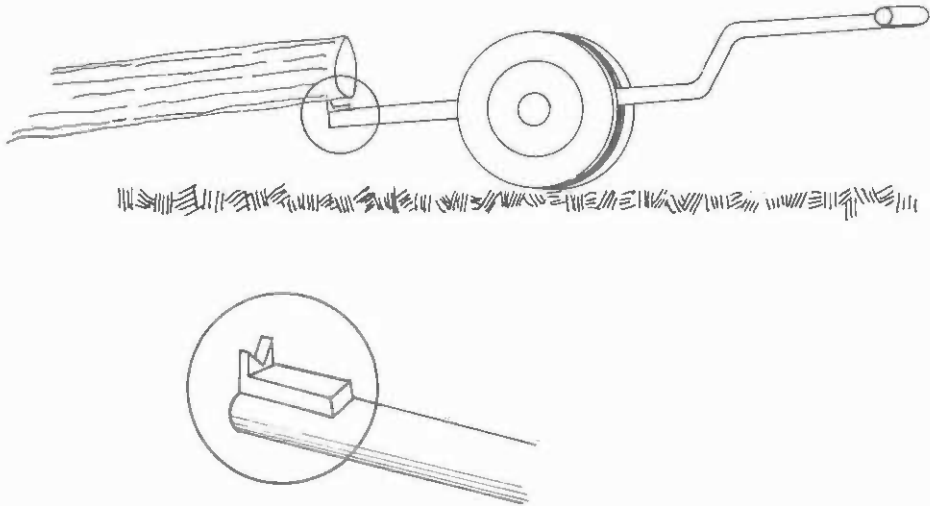

11. Hand sulky

Use
To lift and move small logs.

Material
The frame, wheel attachments and braces are made of channel iron. The attachment for chain chokers is made of angle iron. Channel iron 30 x 30 x 30 x 5 x 6 800 mm, angle iron 30 x 30 x 5 x 300 mm, pipe 40 mm Ø x 400 mm, 2 wheels, 2 axles and a length of chain with a ring at the end.

Instructions
Weld the wheel attachments (1) to the front piece (2) and weld on the wheel braces (3). Weld the sulky pull (4) to the centre of the front piece and weld on the pull braces (5). Cut slots in the metal angle (see detail) for a chain choker to hold the logs. Each slot should be a little wider than the thickness of one chain link. Weld the slotted angle to the centre of the front piece and the pipe handle to the end of the pull. Attach the wheels and axles.

Note
Information on how to use this sulky is given on Sheet 12 of this booklet.

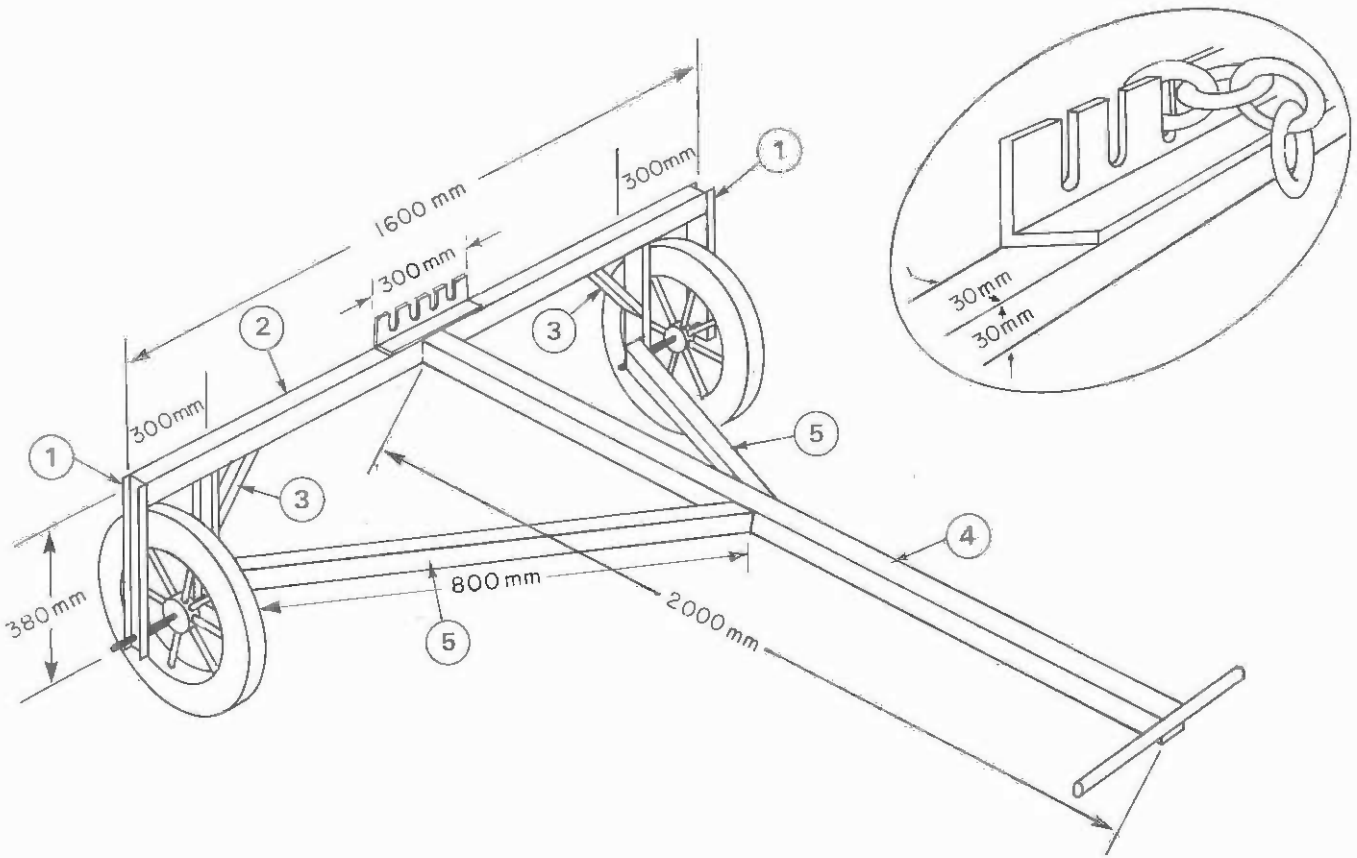

12. Using a hand sulky

Instructions

Stretch out the choker chain on the ground next to the log to be moved (1). Roll the end of the log over the chain (2). Back up the sulky so that the slotted angle is over the end of the log and the chain and tip the sulky up (3). Slip the end of the chain through the ring and pull tight. Then fit a link of the chain into the slots in the angle and tip the sulky down (4). One end of the log will be lifted off the ground so that you can drag it (5). You can also chain the log at the centre, if it is not too long, and lift it clear off the ground (6). If the logs are not too big, you can attach two or more to the sulky (7).

1



2

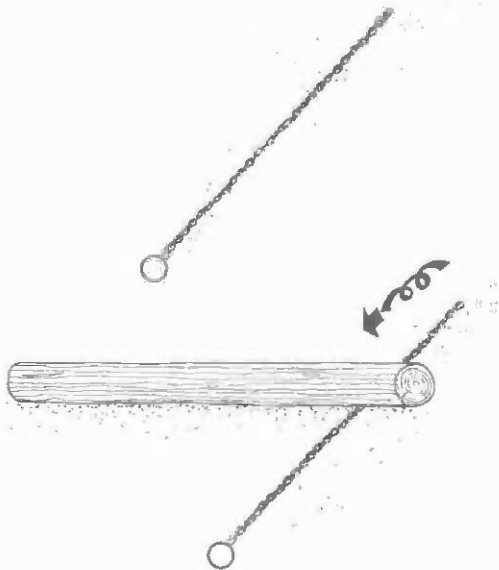

3

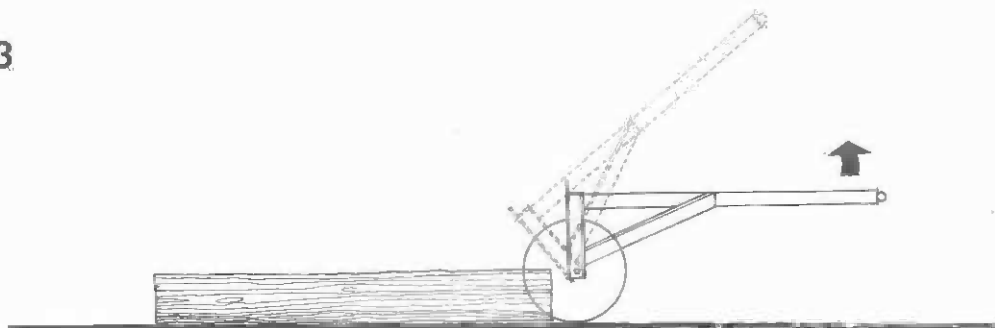

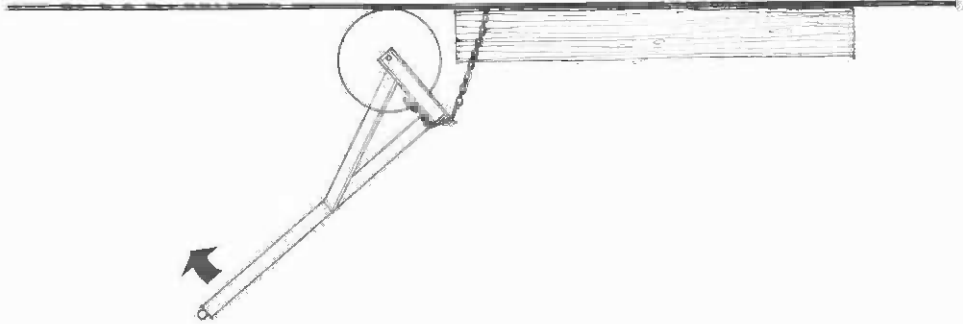
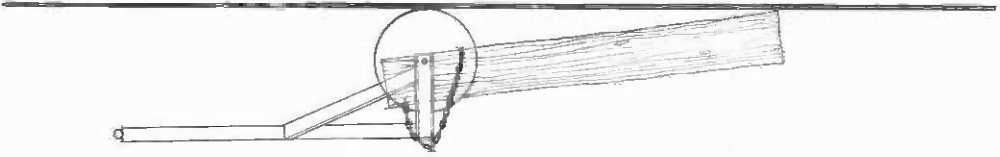
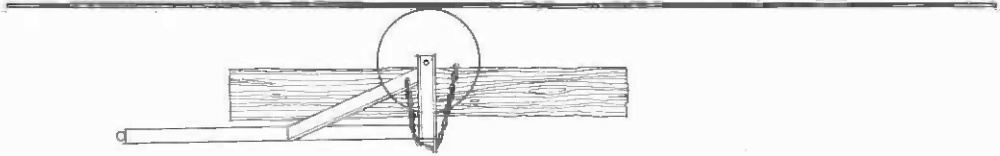
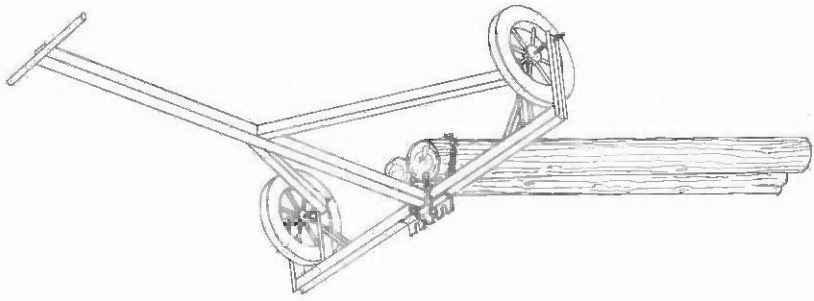
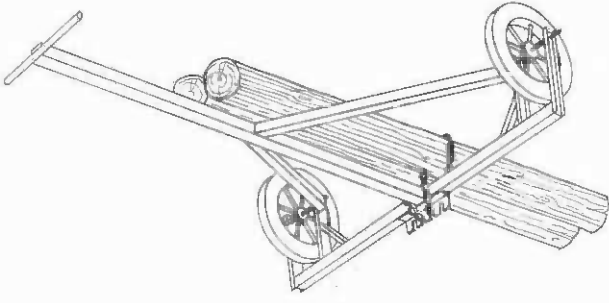

7

6

5

4

13. Using a sulky on steep slopes 1

Material

2 sulkies, 1 pulley block and chain, 5 mm Ø cable of required length.

Instructions

Attach the pulley block to a tree or other fixed object at the top of the slope. Thread the cable through the block and fasten one end to a loaded sulky above and the other end to an empty sulky below. The loaded sulky moving downhill will be slowed by the weight of the empty sulky being pulled uphill. This method is used on slopes of over 40 percent.

Note

This method can be used with the hand sulky (Sheet 11, Booklet 2), with the self-loading timber arch (Sheet 12, Booklet 3) or with a less heavy version of the logging sulky with tongs (Sheet 13, Booklet 3).

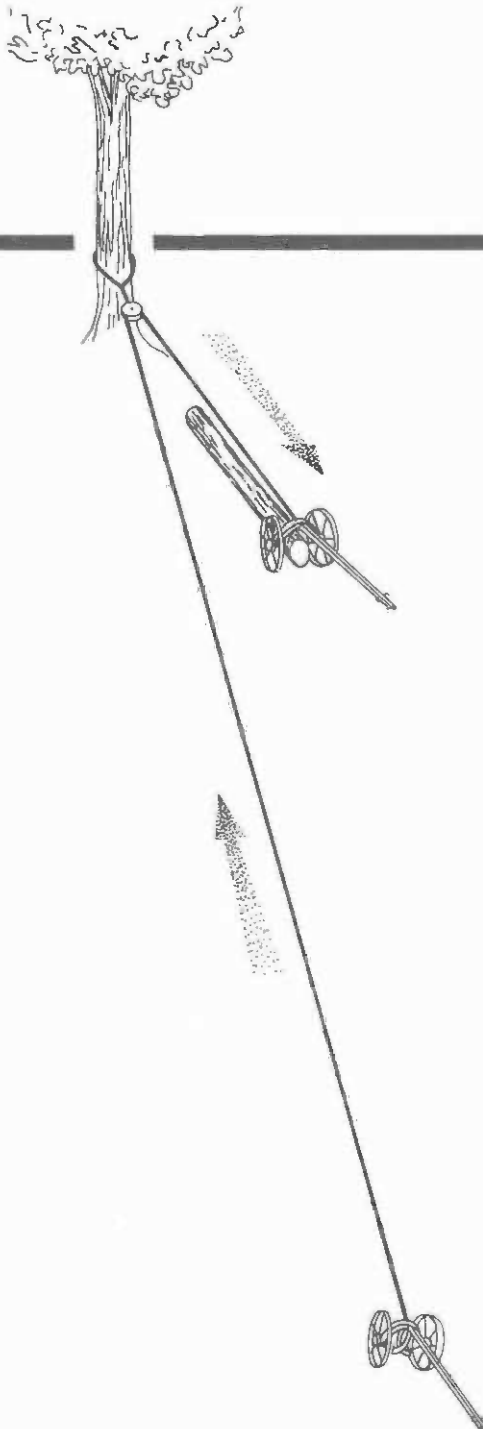

14. Using a sulky on steep slopes 2

Material

2 sulkies, 2 pulley blocks and chains, 5 mm Ø cable of required length.

Instructions

Attach the pulley blocks to two trees or other fixed objects at the top of the slope. By using two pulley blocks, sulkies can operate on two separate tracks to two separate landings. Thread the cable through both blocks and fasten one end to a loaded sulky above and the other end to an empty sulky below. The loaded sulky moving downhill will be slowed by the weight of the empty sulky being pulled uphill. This method is used on slopes of over 40 percent.

Note

This method can be used with the hand sulky (Sheet 11, Booklet 2), with the self-loading timber arch (Sheet 12, Booklet 3) or with a less heavy version of the logging sulky with tongs (Sheet 13, Booklet 3).

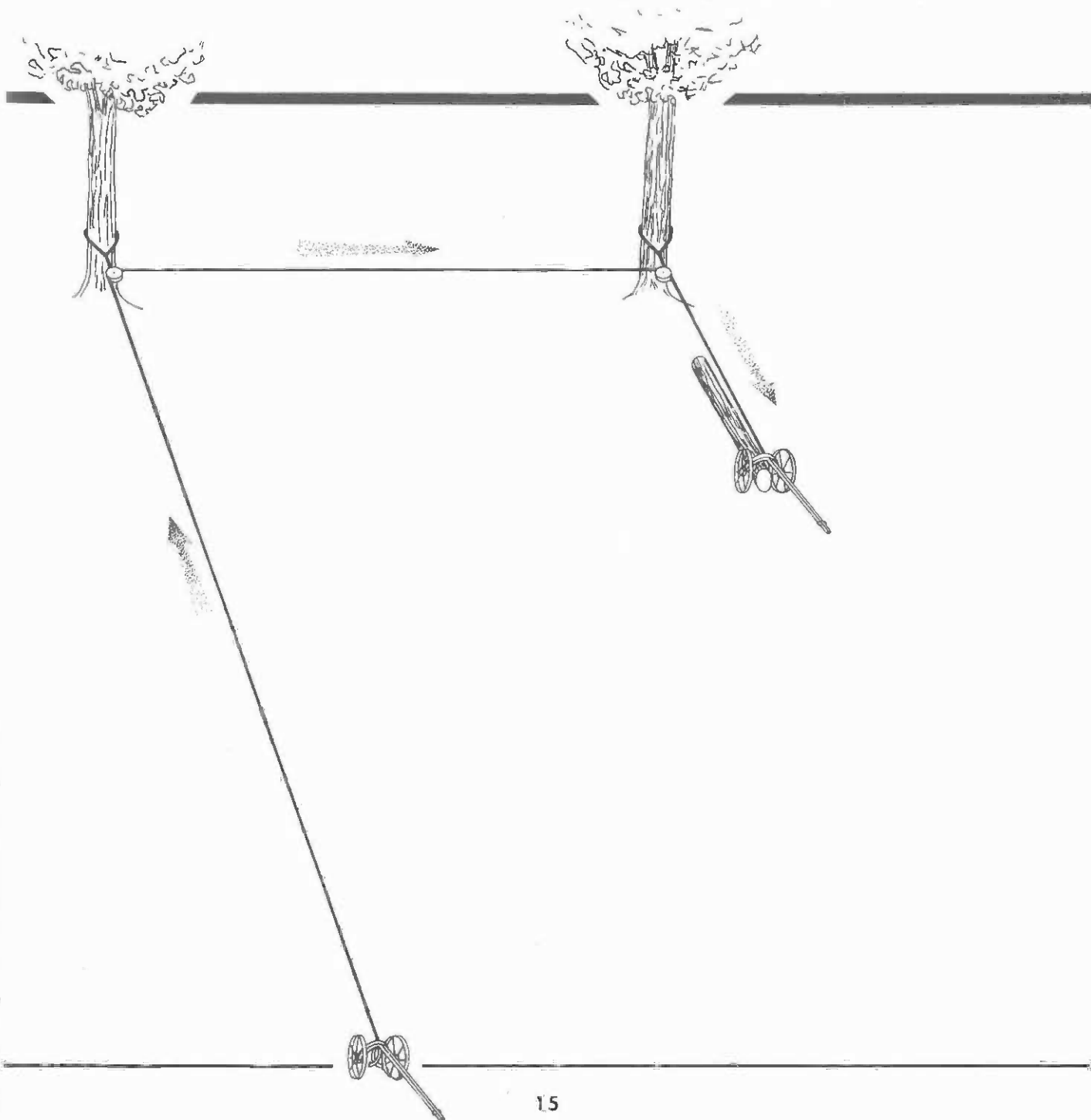

15. Rolling logs by hand

Use

To move short or long logs.

Materials

Poles as straight, long and uniform in size as possible,
4 or 5 pieces of wood 70 mm Ø.

Instructions

Lay the poles parallel on the ground to make a rollway. Larger diameter poles may be needed to span depressions in the terrain or clear obstacles such as rocks. Place the butts of the poles in the direction that the logs are to be rolled. Short logs can be rolled directly on the rollway (1). Long logs can be moved on short wooden rollers (2). As the rollers come free at the rear of the log they are placed in position at the front of the log.

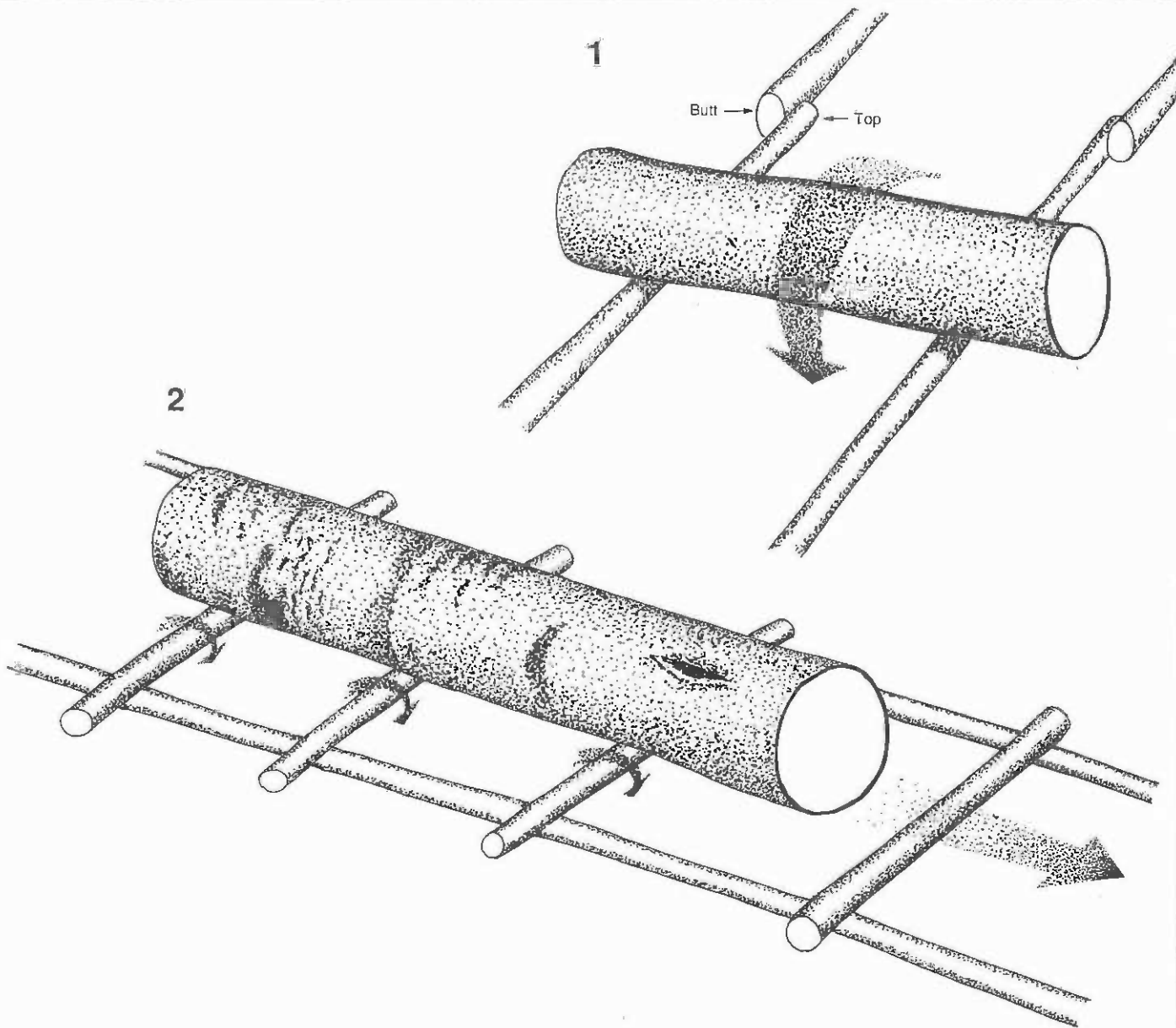

16. Wooden chute

Use

To move logs less than 2 m long over steep and difficult terrain.

Materials

For each section of chute: 2 hardwood boards 5 000 x 200 x 25 mm, 3 strips of flat iron 400 x 50 x 10 mm, 12 bolts 10 mm Ø x 45 mm with washers and nuts, 1 metal hook of 10 mm Ø.

Instructions

Bend the pieces of flat iron at the centre to a right angle. Drill four holes in each angle and six holes in each board (1). Countersink the holes on the inside edge of each board so that the bolt heads will be below the surface. Bolt the angles and boards together with the hook threaded on the centre of the angle on the top end of the board (2). The 50 mm gap between the bottom edges of the two boards allows bark and wood chips to drop through. To assemble the chute, hook the sections together (3). It is important that the upper sections overlap the lower ones so that logs can slide freely (4). This kind of chute can be quickly put together or taken apart and moved to another place. It can be used in lengths of up to 100 m on slopes greater than 60 percent.

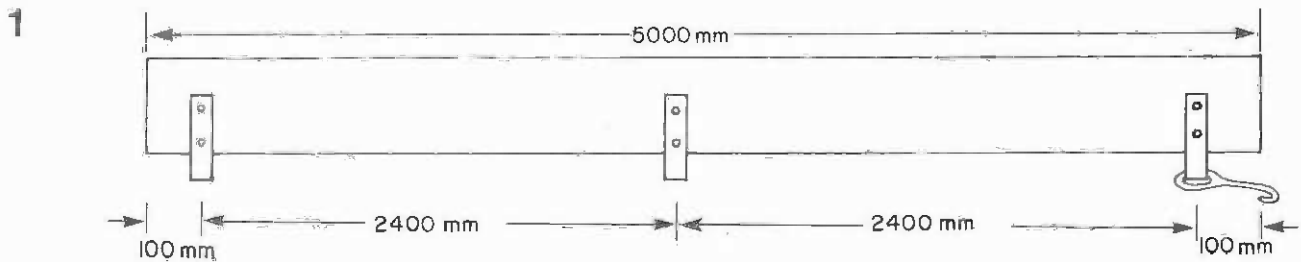

2

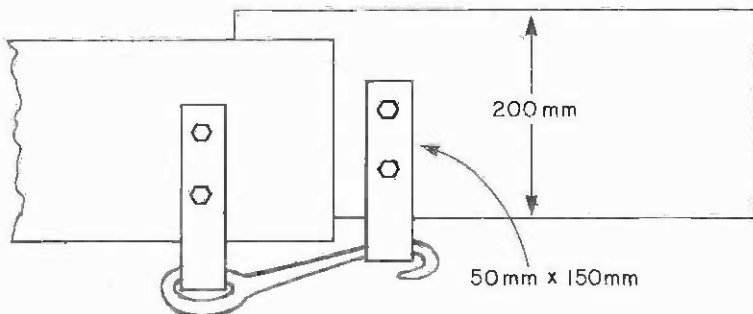

3

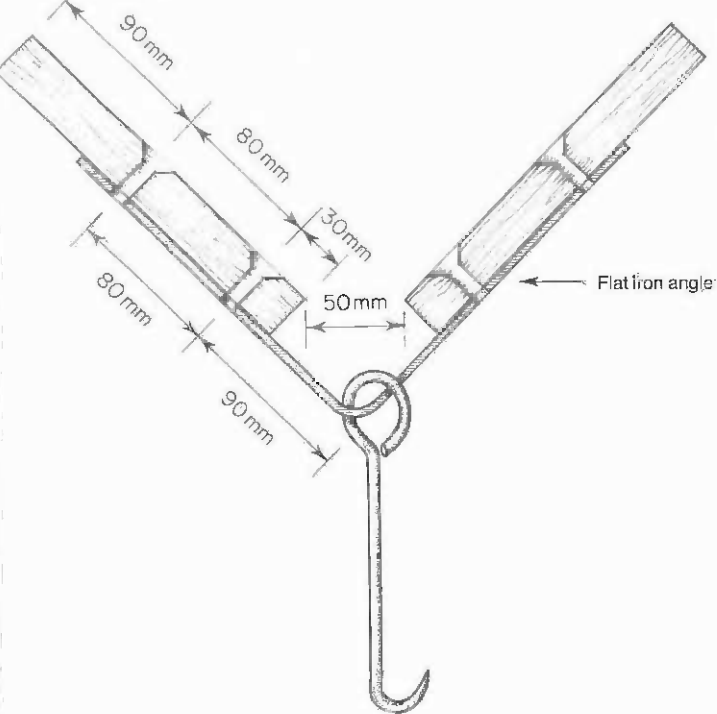

4

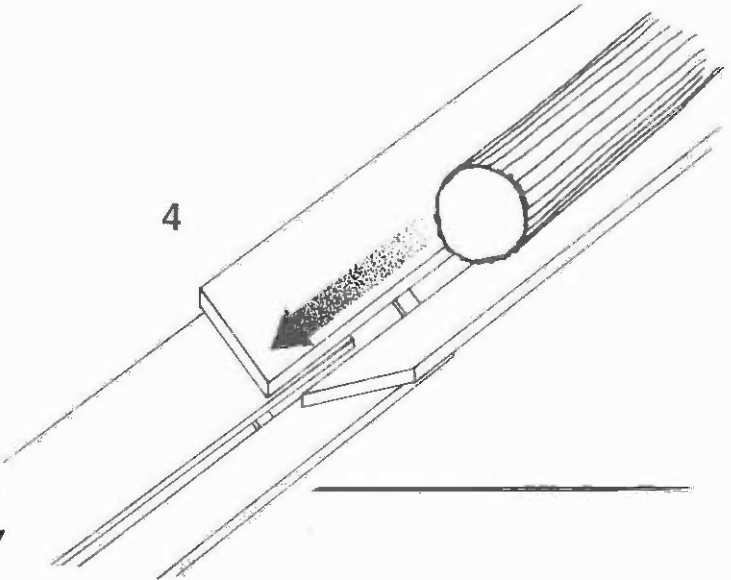

17. Metal chute

Use

To move logs less than 2 m long over steep and difficult terrain.

Material

For each section: 1 piece of sheet metal 2 400 x 600 x 2 mm (aluminium is light and easy to handle if available, otherwise sheet iron), 2 strips of metal 2 400 x 30 x 3 mm, 20 rivets 3 mm \varnothing x 8 mm.

Instructions

Fold the sheet metal lengthwise at the centre to form a wide angle of 125° . Fold the edges down on both sides 40 mm to form a right angle. Rivet the metal strips to each side. Drill a number of holes in the edges to be used for nails or wire to fasten the chute. To assemble the chute, nail the sections to a double row of wooden poles. Chute sections can also be anchored using wire and stakes driven into the ground. It is important that the upper sections overlap the lower ones so that the logs can slide freely. This kind of chute can be put together or taken apart and moved to another place. It can be used in lengths of up to 300 m on slopes greater than 60 percent.

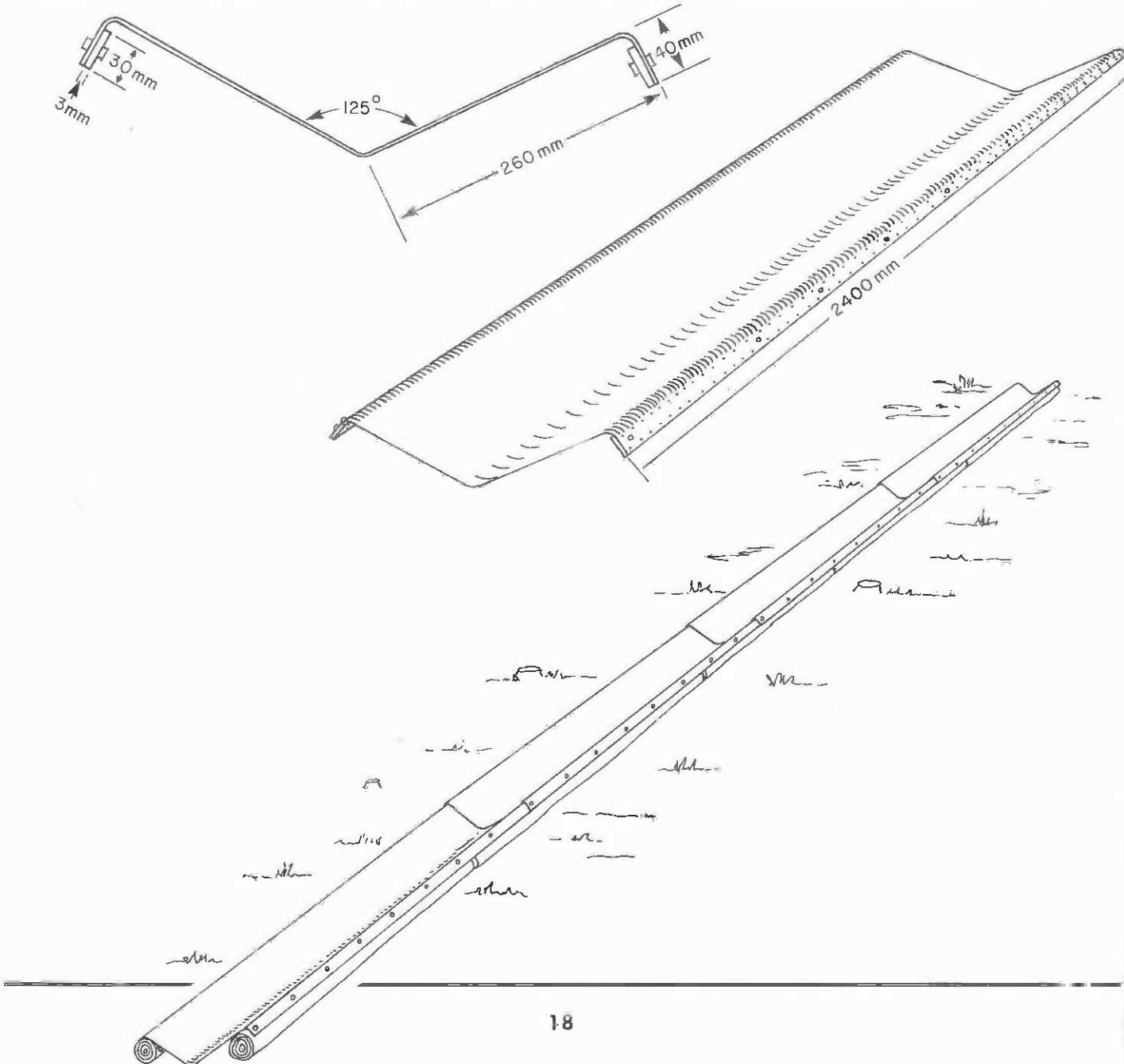

18. Log sledge

Use

To move heavy logs by hand or by winch and cable.

Material

Wooden poles and cross pieces for the skid road, heavy rough sawn lumber for the sledge, leather or canvas straps, rope.

Instructions

The sledge shown in the diagram is pushed or pulled over a skid road of poles (1) laid parallel on the ground, levelled and notched every 500 mm to receive cross pieces (2). The sledge runners (3) are curved at each end (4) so that the sledge can be moved both backward and forward. The runners are rounded (5) to reduce friction. Log bunks (6), notched into the runners, are carved out to hold the load in place. A centre piece (7) provides additional stability. Holes are drilled in both ends of the runners (8) for cable or rope pulls. For loading, the sledge is held in place by two heavy stakes (9) against the opposite runner to keep it from sliding off the skid road. Pegs may be driven into the log being carried to provide handholds for pushing or pulling. Wide shoulder harnesses for pulling (10) are fastened to the sledge by ropes or canvas straps. An axe may be buried in the front of the log for steering. Four or six people may be needed to move the sledge along the skid road.

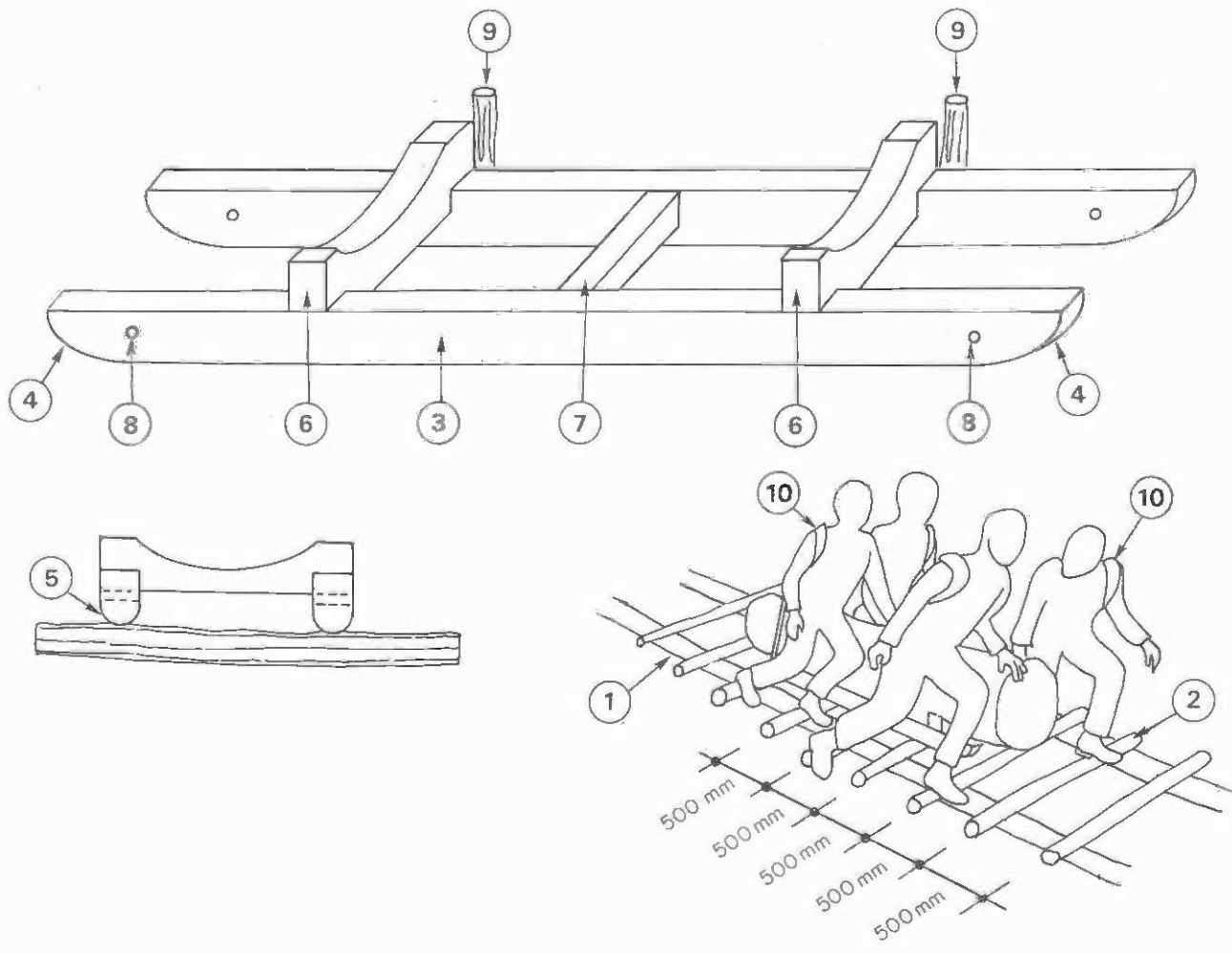

19. Narrow-gauge track

Use

To move heavy logs manually or with animals.

Material

Old narrow-gauge railway rails, logs, 2 000-mm ties, planks, spikes, rough sawn lumber, narrow-gauge railway wheels and axles.

Instructions

A narrow trail is cleared as straight as possible (1). Parallel rows of logs (2) are laid down and levelled. Ties (3) are laid across the logs every 500 mm. The narrow-gauge rails are laid out and spiked (4) to the ties. A plank walkway (5) is laid down between the rails for the people or animals pushing or pulling loads of logs. Wagons (6) are mounted on narrow-gauge axles and wheels (7).

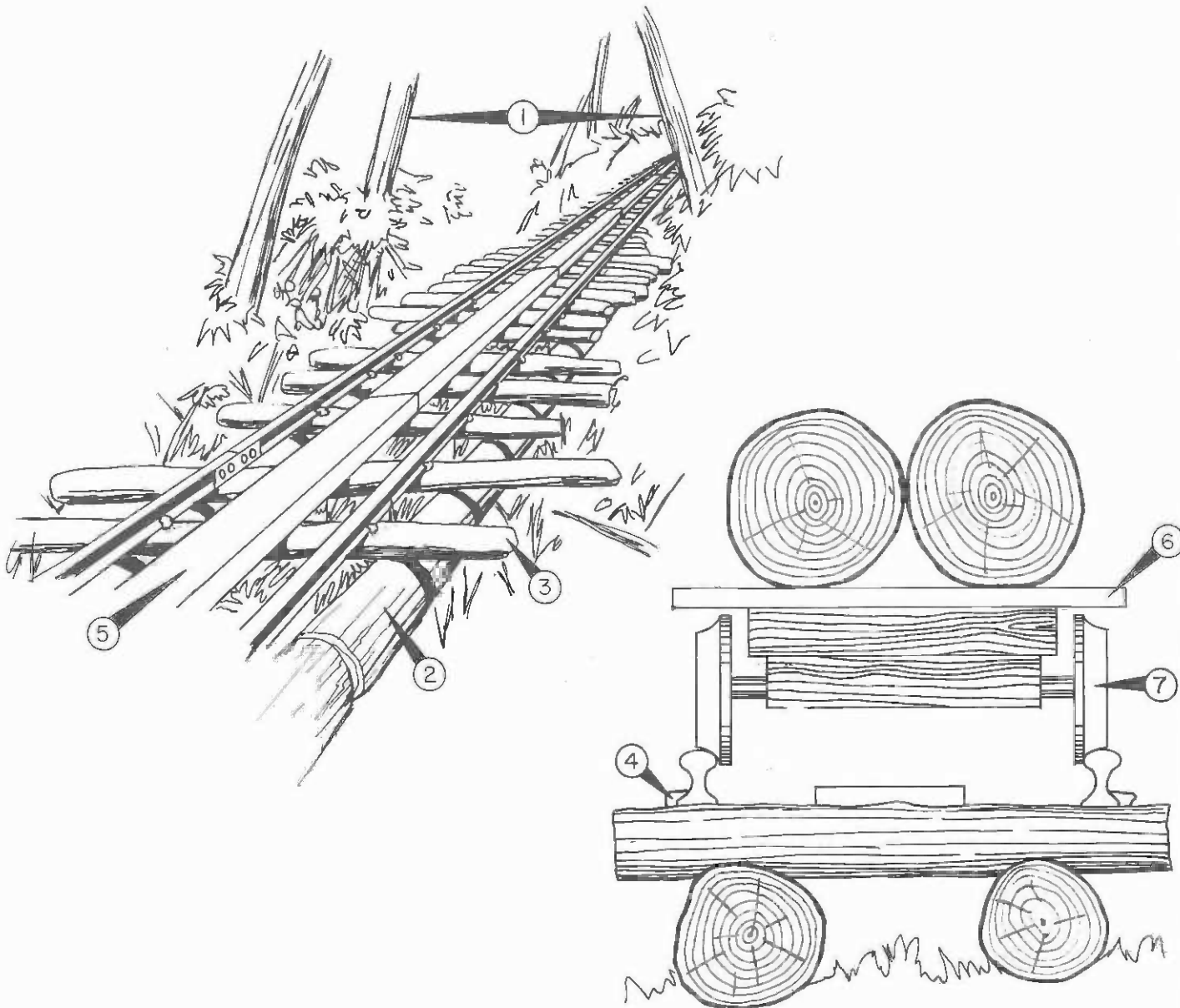

20. Pole track

Use

To move heavy logs manually or with animals.

Material

Medium to heavy logs, long poles, planks and wire or spikes, heavy timber, blocks of wood or sections of logs, metal rods and metal disks with cotter pins.

Instructions

Depending on the size of the logs to be used and the weight of the loads to be carried, place log ties 1 to 1.5 m apart (1). Mount the track of poles on the ties using wire or spikes (2). If wire is used it should be attached so that it cannot be cut by the wheels. A plank walkway (3) is laid down between the tracks for the people or animals pushing or pulling loads of logs. The wagon is a simple platform built of heavy timber. The wheels, carved from blocks of wood or sections of logs, have deep grooves to ride the poles (4). The wheels are free to move back and forth on metal rod axles (5) between metal disks held in place with cotter pins (6) to allow for variations in track alignment.

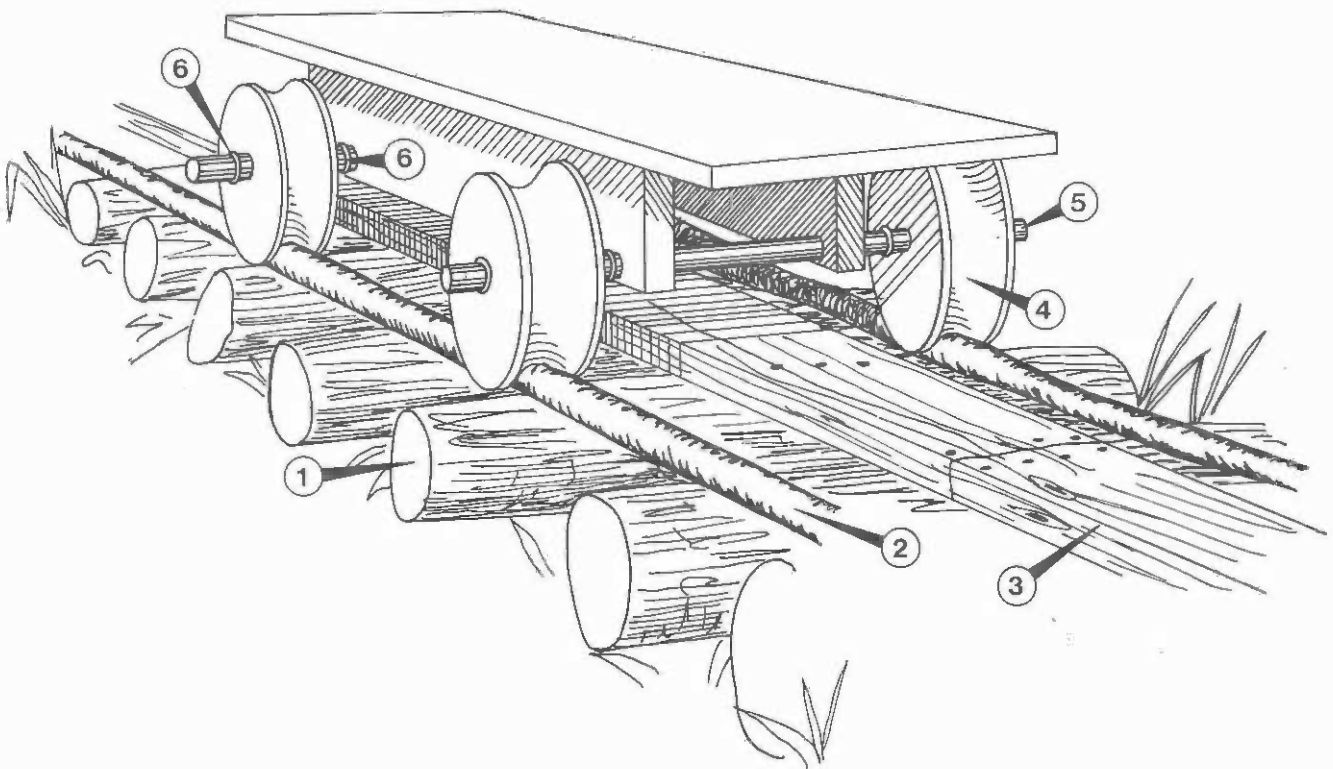

DESIGN MANUAL ON BASIC WOOD HARVESTING TECHNOLOGY

BOOKLET 3

MOVING LOADS WITH ANIMAL POWER

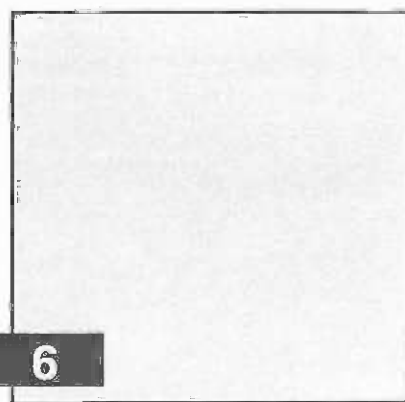
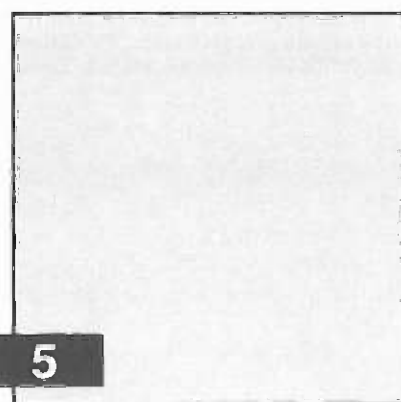
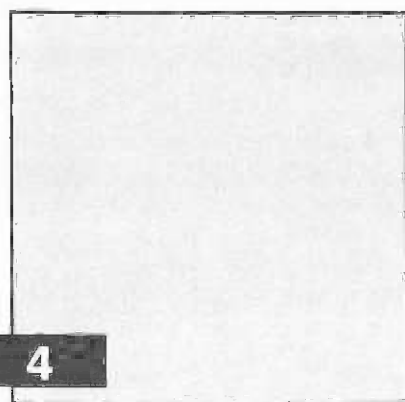
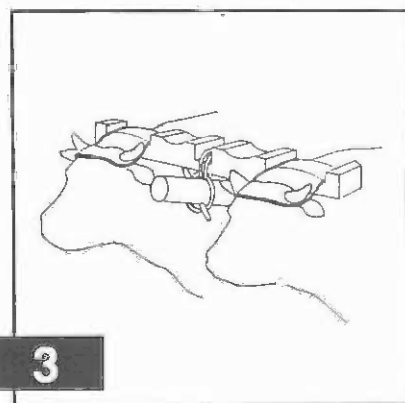
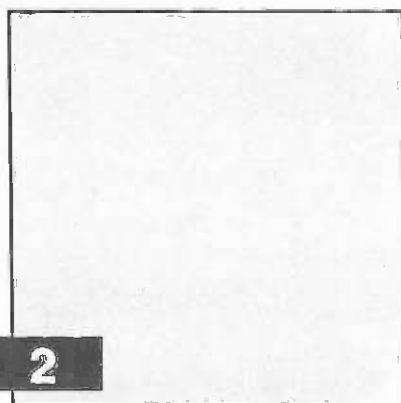
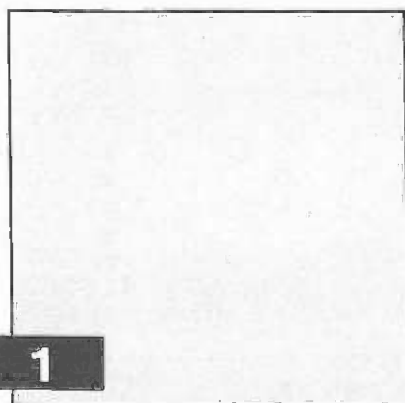

The designations employed and the presentation of material in this publication do not imply the expression of any opinion whatsoever on the part of the Food and Agriculture Organization of the United Nations concerning the legal status of any country, territory, city or area or of its authorities, or concerning the delimitation of its frontiers or boundaries.

M-39
ISBN 92-5-102537-1

All rights reserved. No part of this publication may be reproduced, stored in a retrieval system, or transmitted in any form or by any means, electronic, mechanical, photocopying or otherwise, without the prior permission of the copyright owner. Applications for such permission, with a statement of the purpose and extent of the reproduction, should be addressed to the Director, Publications Division, Food and Agriculture Organization of the United Nations, Via delle Terme di Caracalla, 00100 Rome, Italy.

© FAO 1989

Contents

1. Saddle-rack 1
 2. Saddle-rack 2
 3. Skidding harness 1
 4. Skidding harness 2
 5. Head yoke for oxen
 6. Shoulder yoke for oxen
 7. Skidding hooks
 8. Skidding tongs
 9. Skidding cone
 10. Skidding sled
 11. Skidding cradle
 12. Logging sulky with tongs
 13. Self-loading timber arch
 14. Single skid runner
 15. Log sledge 1
 16. Log sledge 2
 17. Wood pallet with runners
-

Symbols and abbreviations used

°	Degree (angle)	
∅	Diameter measurement	
kg	Kilogram	= 2.205 pounds (lb)
m	Metre	= 1.094 yards (yd)
mm	Millimetre	= 0.0394 inch (in)

Note

Additional valuable information on the kinds of tools shown in this booklet can be found in FAO Forestry Paper 36, *Basic Technology in Forest Operations* (ISBN 92-5-101260-1).

1. Saddle-rack 1

Use

To carry short lengths of wood by donkey or mule.

Material

Use round lightweight wood. For each saddle-rack: 8 pieces 25 mm \varnothing x 450 mm, 2 pieces 25 mm \varnothing x 620 mm, strong cord, strips of leather or wire, a length of rope and a hook, 2 leather or fibre straps.

Instructions

Lash the six shorter pieces of wood together to form the back and side of the saddle-rack as shown. Lash the two longer pieces of wood diagonally to the corners of the back. Tie the length of rope to the back and hook it to the top of the side. Make a second saddle-rack exactly the same. To attach the two saddle-racks, put the two straps over the back of the animal and fasten them to the top of each rack.

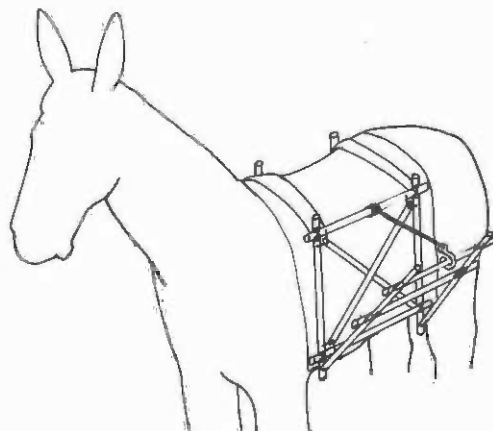
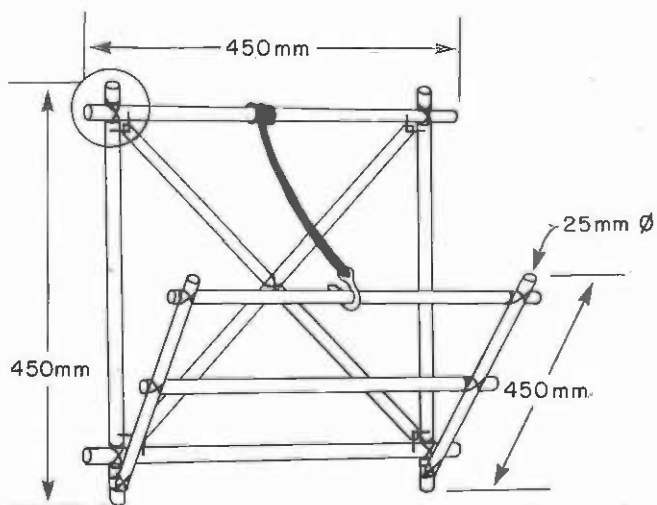
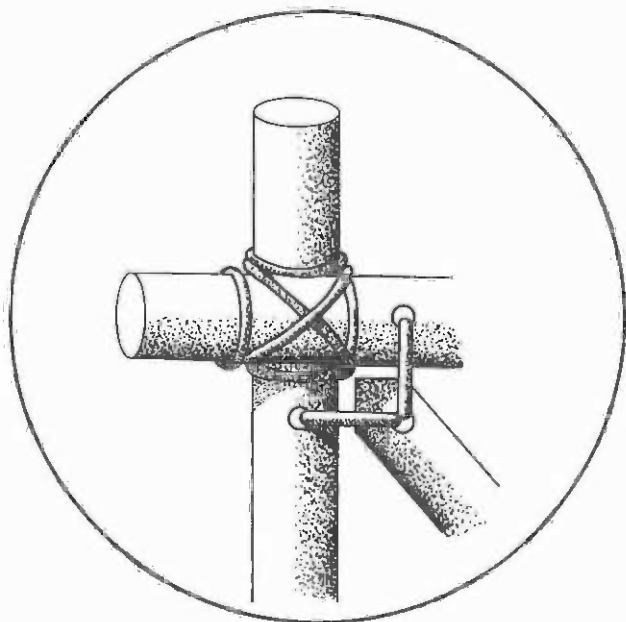

2. Saddle-rack 2

Use

To carry short lengths of wood or drag logs by donkey or mule.

Material

4 wooden boards 400 x 50 x 20 mm, 1 piece of wood 400 x 50 x 50 mm, nails, 2 leather or fibre straps, a rope.

Instructions

Cut a notch 20 mm wide x 25 mm deep at a point 120 mm from the upper end of each of the four boards. Assemble the four notched boards to form two cross-pieces. Cut the remaining piece of wood in half lengthwise on the diagonal and nail one cross to each end as shown. Drill a hole near the bottom of each cross and attach the straps to hold the rack in place on the animal's back. Short lengths of wood in equal amounts can be tied to each side of the rack (1) or one or more logs can be tied to each side of the front (2) and dragged beside the animal. To tie the rope to the rack, notches can be cut in the ends of the cross-pieces.

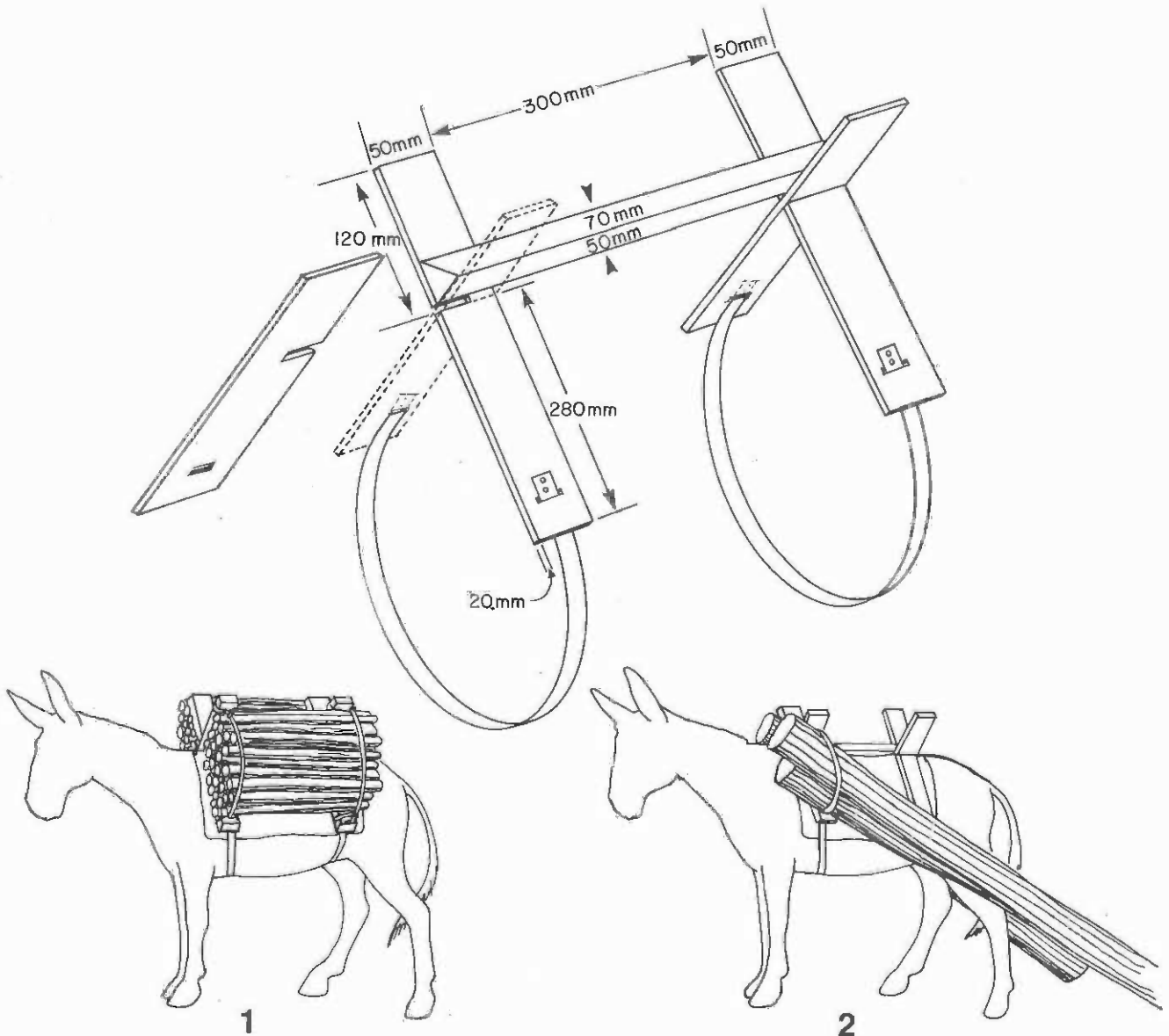

3. Skidding harness 1

Use

To pull loads or drag logs by donkey or mule.

Material

A draught-animal collar with crupper strap, 2 pieces of heavy chain long enough to reach from the collar and extend well behind the heels of the animal, a heavy hook and eye, 2 leather or fibre straps, a piece of wood 50 mm \varnothing x 560 mm, a short piece of heavy chain.

Instructions

Shape the round piece of wood as shown. Attach the two long pieces of chain to the sides of the collar. Join the ends of the chains with the hook and eye. Pass one of the straps under the animal (1) and one of the straps over the animal (2) and attach them to the chains on both sides. Insert the round piece of wood in the chains (3) to hold them apart behind the animal. Pass the short piece of chain around the log to be pulled and attach it to the hook (4).

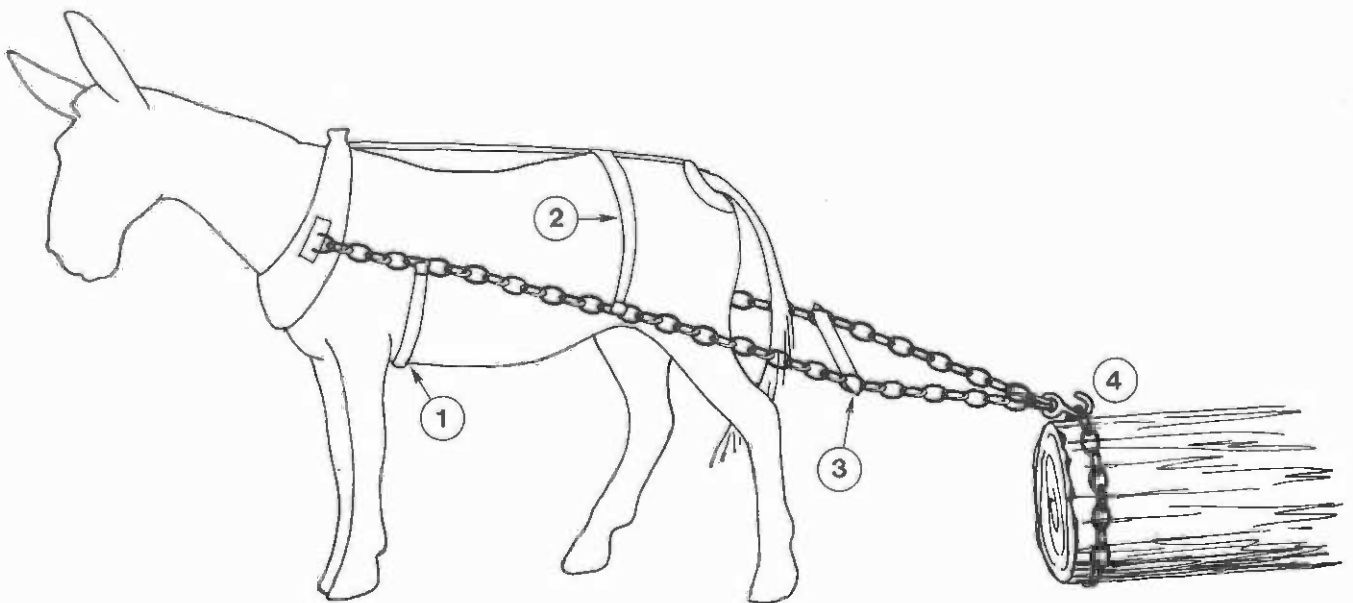
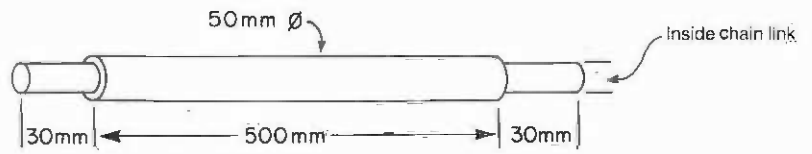

4. Skidding harness 2

Use

To pull loads or drag logs by donkey or mule.

Material

A draught animal collar with crupper strap, 2 pieces of heavy chain long enough to reach from the collar and extend well behind the heels of the animal, a singletree, 2 leather or fibre straps, a short piece of heavy chain.

Instructions

Attach the two long pieces of chain to the sides of the collar. Attach the singletree to the ends of the chains (1). Pass one of the straps under the animal (2) and one of the straps over the animal (3) and attach them to the chains on both sides. Pass the short chain around the log to be pulled and attach it to the hook (4).

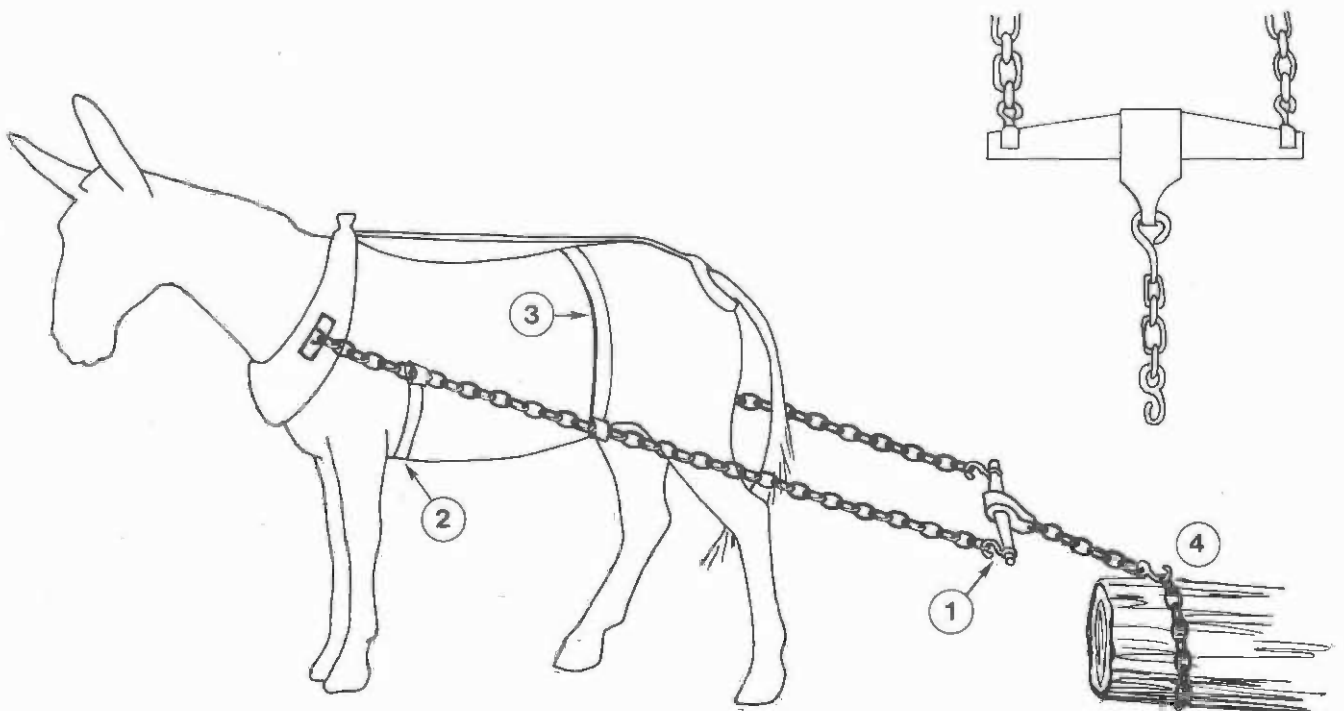

5. Head yoke for oxen

Use

To pull logs or carts.

Material

1 piece of wood 2 000 x 150 x 150 mm (weight 12 to 15 kg), 80 mm Ø ring made from 10 mm Ø iron rod, 2 pieces of thick cloth 400 x 200 mm, 3 rawhide strips of appropriate length.

Instructions

Shape the piece of wood to form the yoke as shown below. The final shape will depend on the size of the oxen. When the yoke is finished it should fit the head of both animals just behind the horns. Lash the ring to the centre of the yoke (1) using one of the rawhide strips. Put a piece of thick cloth on the head of each animal to keep the yoke from rubbing. Lash the yoke tightly to the horns (2) with the two remaining rawhide strips. The load to be pulled is attached to the ring. The pole of a cart can be pushed through the ring and held in place with a pin.

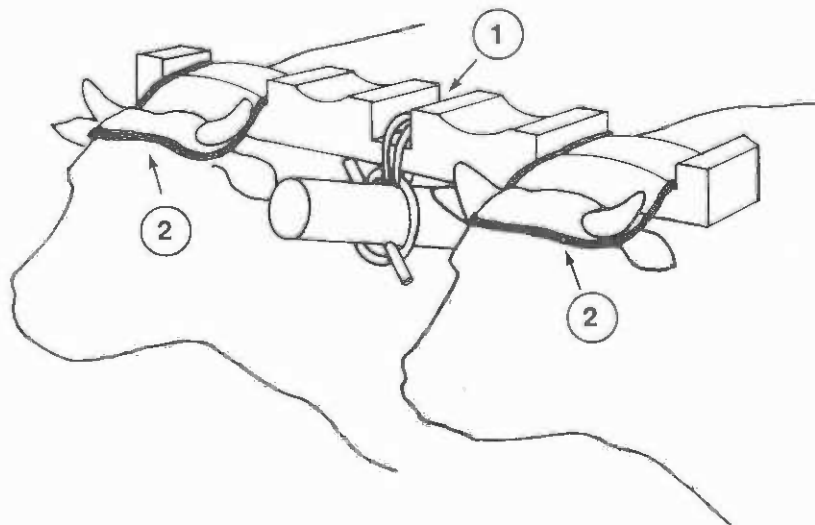
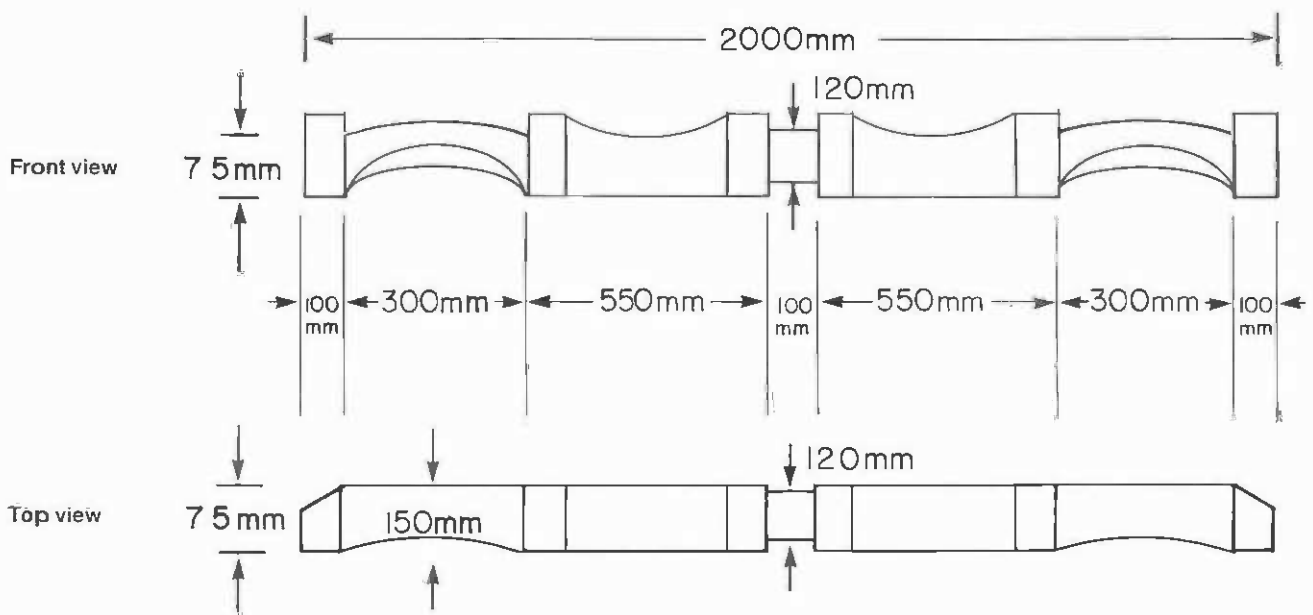

6. Shoulder yoke for oxen

Use

To pull logs or carts.

Material

A piece of wood 1 200 x 200 x 100 mm, 2 round pieces of wood (such as rattan or willow) 25 mm Ø or 2 pieces of iron rod 15 mm Ø x 1 000 mm, 1 bolt 10 mm Ø x 250 mm with an eye and a ring made from 10 mm Ø iron rod 80 mm long.

Instructions

Shape the piece of wood to form the yoke as shown below. The final shape will depend on the size of the oxen. When the yoke is finished it should fit the necks of both animals just in front of the shoulders. Drill four holes in the yoke for the neck hoops using the dimensions shown. Drill a hole in the centre of the yoke for the bolt, eye and ring. Place the yoke on the oxen and slip in the neck hoops. Wooden hoops may have to be wet or steamed to bend them into shape. The load to be pulled is attached to the ring. The pole of a cart can be pushed through the ring and held in place with a pin. The weight of a load being pulled holds the yoke firmly in place against the shoulders.

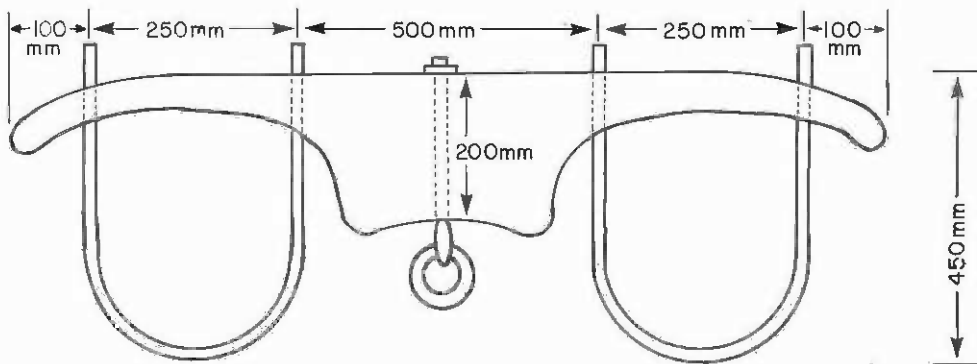

7. Skidding hooks

Use

To pull logs using draught animals.

Material

2 iron rods 15 mm \varnothing x 450 mm, 1 ring 100 mm \varnothing made from 15 mm iron rod, a length of heavy chain.

Instructions

Heat and bend the iron rods to form two hooks with eyes as shown. Sharpen and harden the points. Attach the ring to the length of chain. Drive the hooks into the sides of a log near the end. Thread the chain through the eyes and the ring. When the chain is pulled tight the hooks are forced into the log.

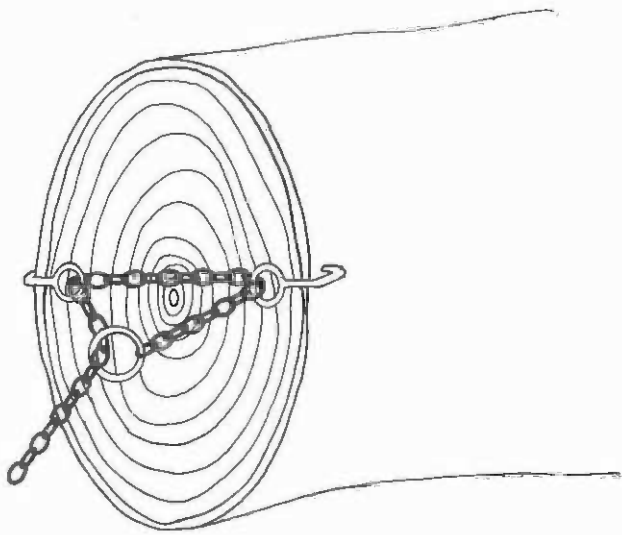
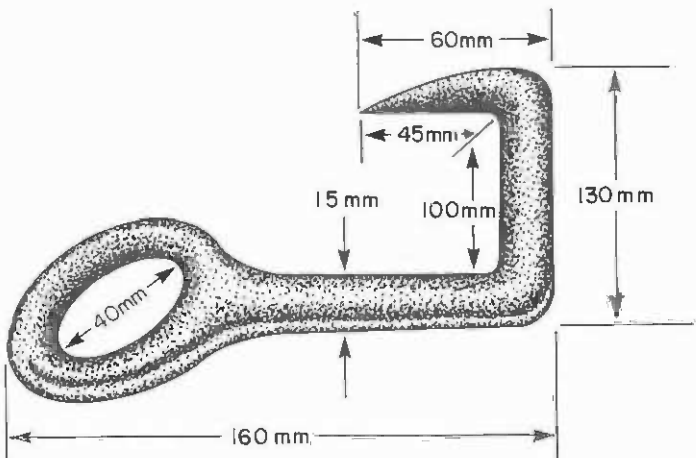

8. Skidding tongs

Use

To pull logs using draught animals.

Material

1 iron rod 15 mm \varnothing x 280 mm (1), 2 iron rods 15 mm \varnothing x 200 mm (2), 2 pieces of steel rod 20 mm \varnothing x 550 mm (3), a length of 10 mm chain x 2000 mm.

Instructions

Heat and bend the steel rods to form two hooks with eyes (3). Sharpen and harden the points. Form the two small rings through the eyes of each hook (2). Form the large ring through the smaller rings (1). Attach the length of chain to the large ring. Place one hook on each side of a log. When the chain is pulled tight the hooks are forced into the log.

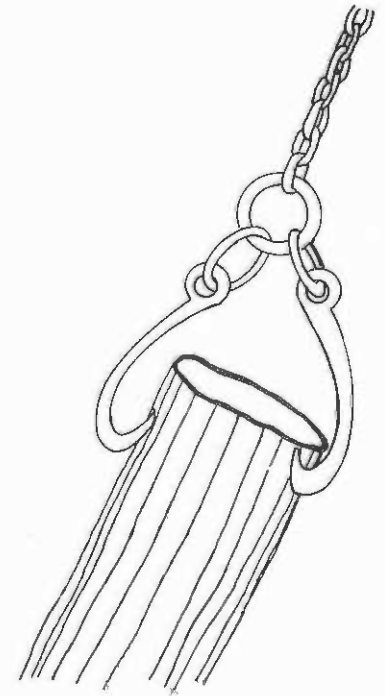
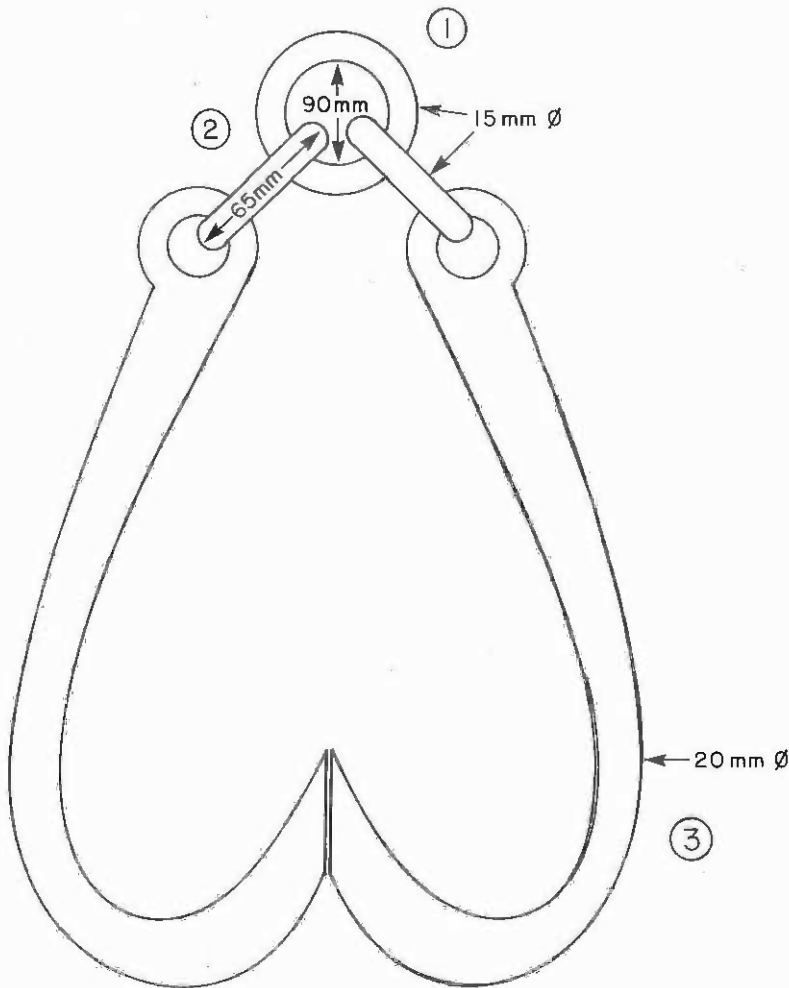

9. Skidding cone

Use

To prevent logs from digging into the ground and being caught on obstacles while being pulled.

Material

A sheet of heavy-gauge flat metal 1 200 x 1 200 x 2-3 mm, an iron rod 10-15 mm \varnothing x 160 mm, 12 rivets.

Instructions

Cut a circle 1 200 mm in diameter from the sheet of metal. Make a cut from the edge of the circle to the centre. Role the circle into a cone so that one half has two thicknesses of sheet metal and the other half has three thicknesses. The diameter of the base of the finished cone will be about 500 mm. Rivet or weld the loose edges of the cone. Cut off the end of the cone to make a hole for the chain. Bend the short iron rod into a ring 50 mm in diameter and weld it into the hole. Attach the chain to the log, thread the chain through the hole in the cone and pull. When using the skidding cone the part with the three thicknesses should be down.

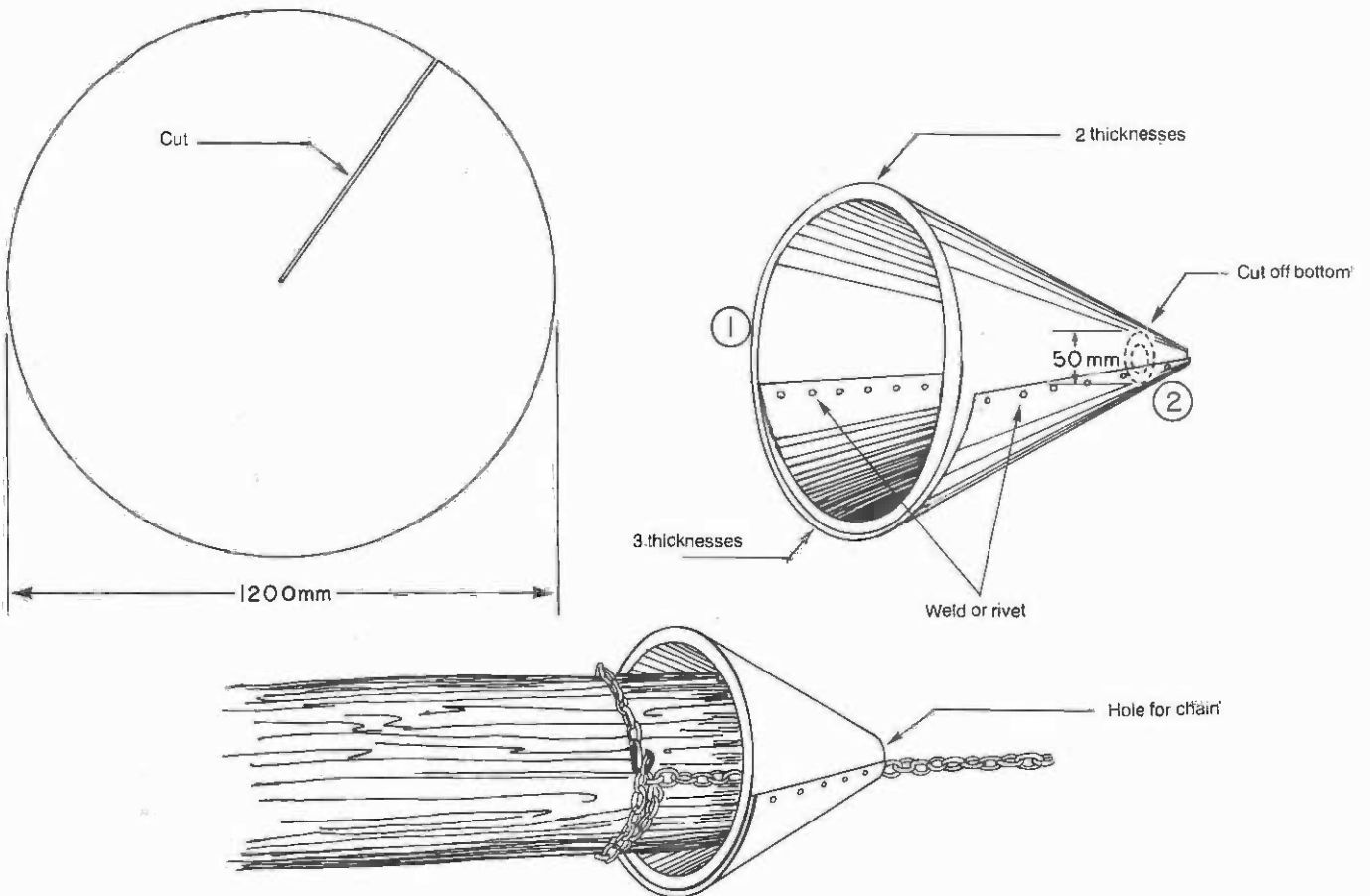

10. Skidding sled

Use

To pull logs using draught animals.

Material

1 piece of pipe 50 mm Ø x 2 500 mm, 1 piece of pipe 50 mm Ø x 1 500 mm, 2 pieces of 50 x 50 mm channel iron x 150 mm, 2 bolts 10 mm Ø x 70 mm with nuts, short pieces of flat iron, a length of chain.

Instructions

Shape the long piece of pipe to form the sled runner. Weld the short pieces of flat iron to the front of the runner to form a pull bar. Weld the two pieces of channel iron to each side of the runner about halfway between the front and the back. Shape the shorter piece of pipe to form an arch. Drill holes through the base of the arch and the channel iron and bolt the arch in place. Weld several iron squares to the top of the arch. Attach the chain to the log to be pulled. Hook the chain through the squares, over the arch and fasten it to the front of the runner (1). The forward movement of the sled will cause the arch to move into the vertical position, lifting the front end of the log off the ground (2).

1

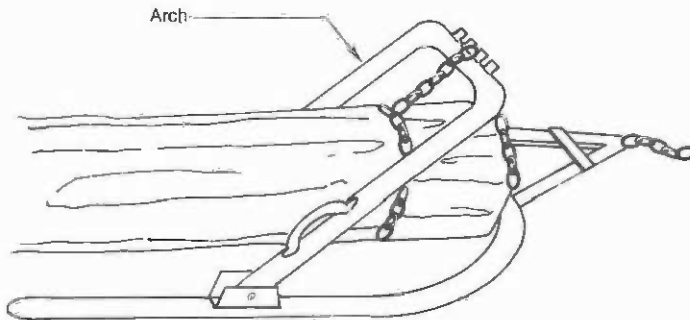

2

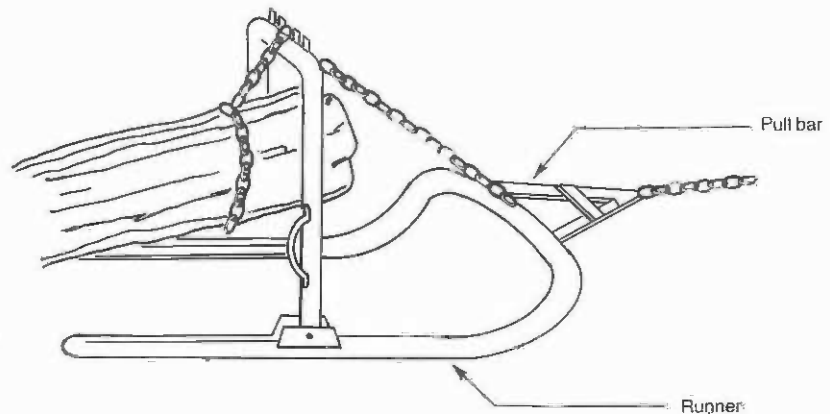

11. Skidding cradle

Use

To carry short lengths of wood downhill or over soft ground.

Material

A section of curved metal 2500 x 1250 mm and at least 2 mm thick (can be cut from a used metal tank), 2 pieces of iron rod 10-15 mm \varnothing x 400 mm or 2 flat metal strips 150 x 100 x 5 mm, 8-12 bolts with nuts, a length of chain 10 mm \varnothing x 4000 mm.

Instructions

Shape the piece of metal so that it has the proper curve. Make two brackets using the iron rods or the metal strips as shown below. Bolt one of the brackets to the outside of the cradle at the rear end (1) and the other bracket to the inside of the cradle at the front end (2). Attach the chain to the rear bracket and thread it through the front bracket. When the cradle is pulled the tension in the chain holds the wood in place.

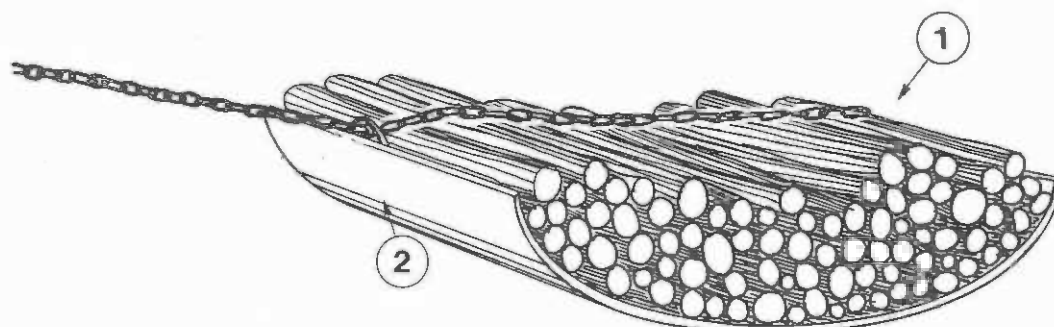
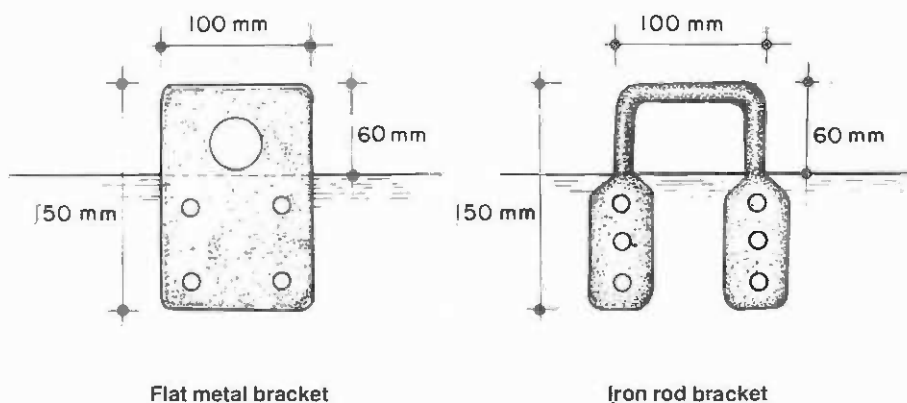

12. Logging sulky with tongs

Use

To lift and carry or drag heavy logs.

Material

Used scrap iron, 2 wheels 2 500-3 000 mm Ø, a pair of heavy metal hook tongs, a length of heavy chain.

Instructions

The design can be varied according to the materials available as long as the parts remain the same (an arch with two wheels, double hook tongs and a long tongue which acts as a lever). Position the sulky over the middle of the log, tip up the tongue and clinch the log with the tongs (1). Pull the tongue down and fasten the other end of the log with the chain to lift the log completely off the ground (2). The tongs can also be attached near the end of the log to lift only that end and drag the other (3). With this sulky only one log at a time can be moved.

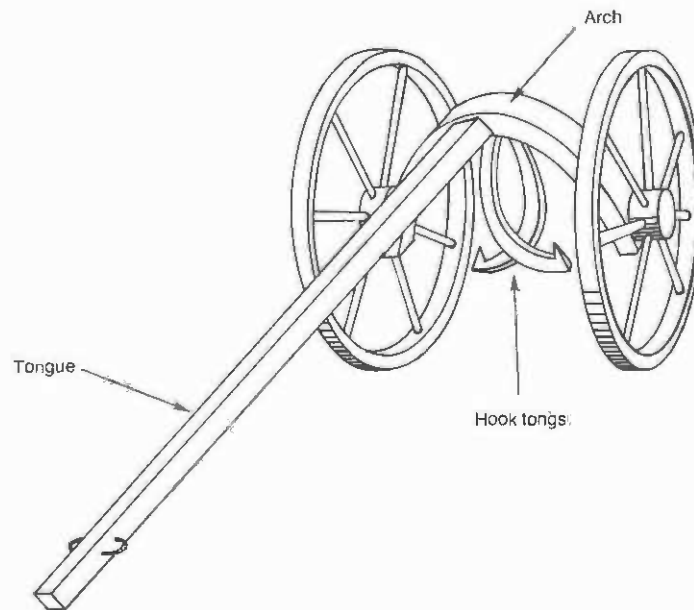

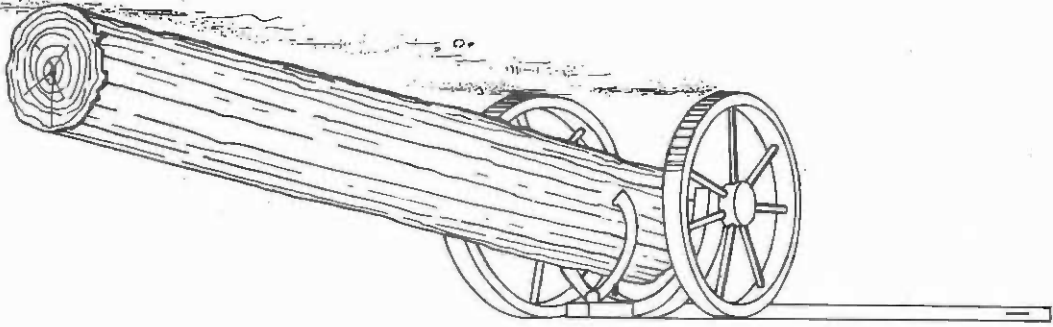

3

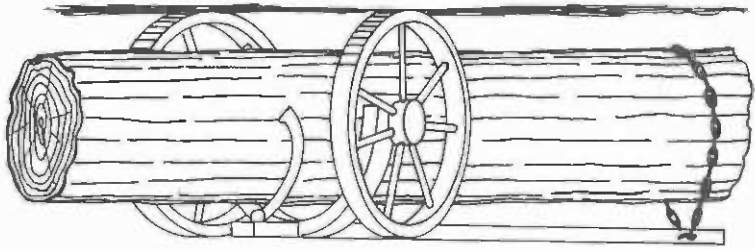

2

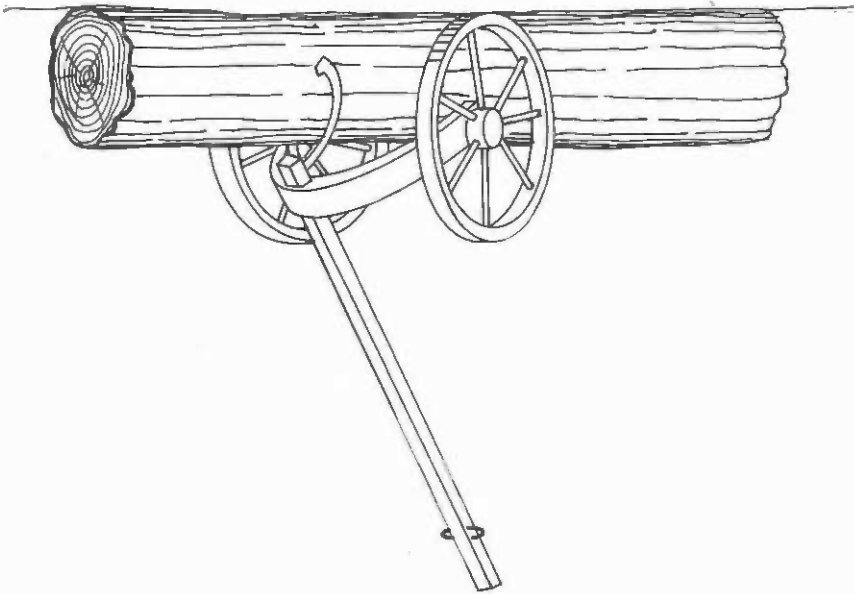

1

13. Self-loading timber arch

Use

To lift and skid one or more logs.

Material

Used scrap iron, 2 used truck wheels with tires, a length of chain.

Instructions

The design can be varied according to the materials available as long as the parts remain the same (an arch with two wheels and a long tongue which acts as a lever). To use the arch, position it over the log or logs as shown; tip up the tongue and secure the load to the centre with the chain (1). Pull down on the tongue and one end of the load is lifted off the ground for skidding (2).

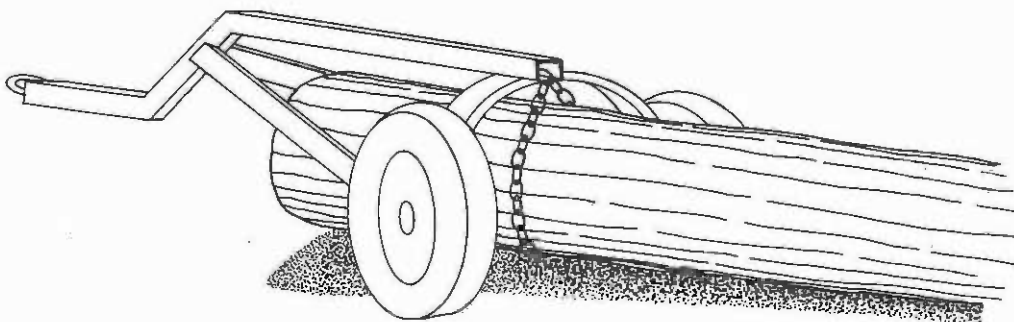
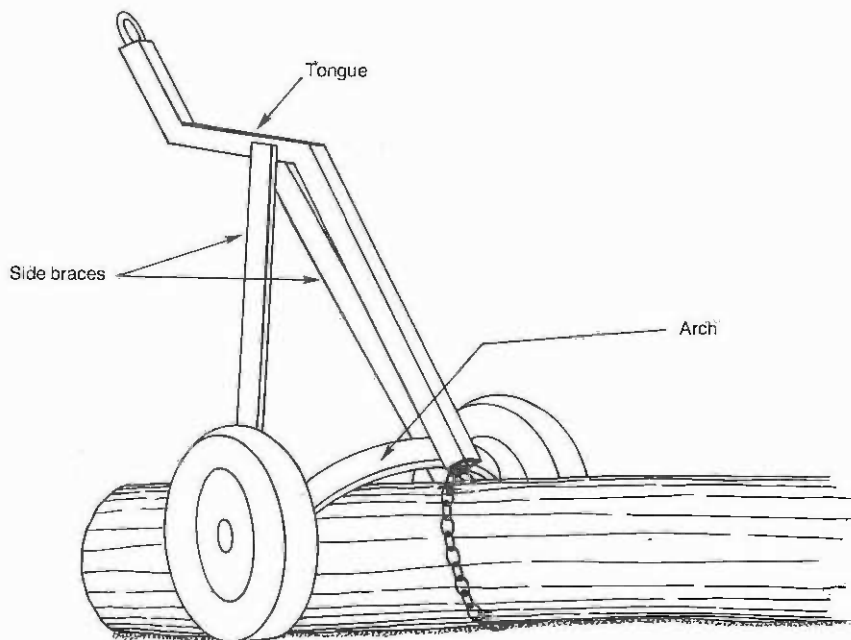

14. Single skid runner

Use

To carry short lengths of wood.

Material

A piece of timber 2 000 x 250 x 250 mm, 2 lengths of chain 2 500 mm, a load binder (see Sheet 11, Booklet 4), 2 bolts 10 mm \varnothing x 260 mm, 20 heavy spikes.

Instructions

Shape the piece of timber by cutting out the central part and rounding both ends to form a double-ended skid as shown below. Drive the spikes through the bottom of the skid so that they extend slightly through the top to hold the load in place. Attach the two lengths of chain to the load binder. Drill two large holes through the front and back ends of the skid for the chains. Drill two smaller holes at right angles through the large holes to bolt both chains in place at the desired length. Open the load binder, fill the skid runner with short lengths and close the load binder. This skid runner can carry about 0.5 cubic metres of short wood lengths.

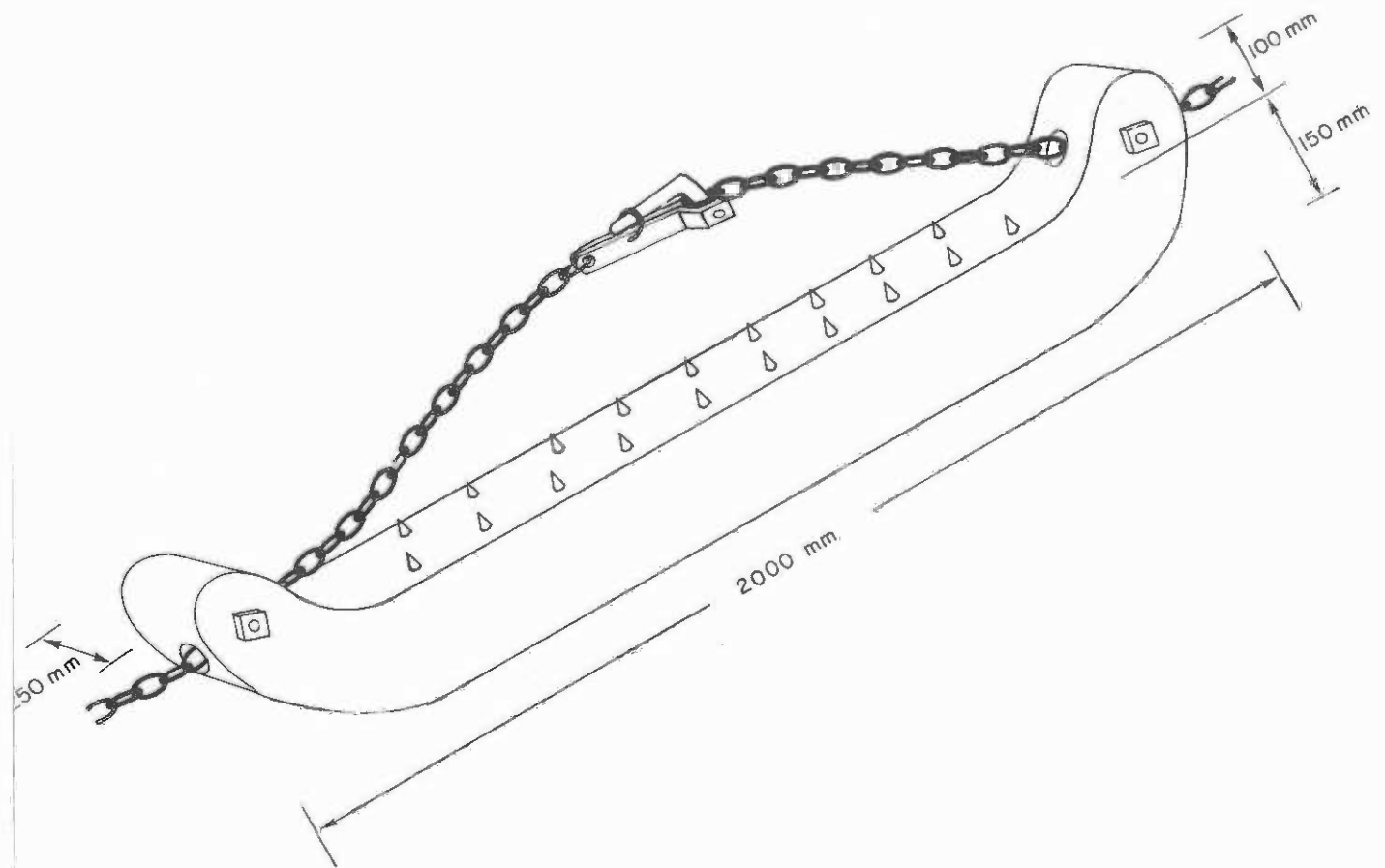

15. Log sledge 1

Use

To carry short lengths of wood or firewood.

Material

2 pieces of pipe 40 mm Ø x 2 700 mm, 4 pieces of angle iron 920 x 40 x 40 mm, 4 pieces of angle iron 450 x 40 x 40 mm, a length of chain, a metal ring, 2 short pieces of iron for the pull.

Instructions

Heat and bend the two pieces of pipe to form the runners of the sled (1). Weld one of the long pieces of angle iron to each runner as a brace (2). Join the runners by welding the four short pieces of angle iron to the underside of the braces (3). Invert the two remaining long pieces of angle iron and weld them to the braces to support the load (4). The sharp edges of the inverted angle will keep the wood from sliding sideways. Attach a pull to the braces at one end of the sledge using the chain, the ring and the short pieces of iron as shown.

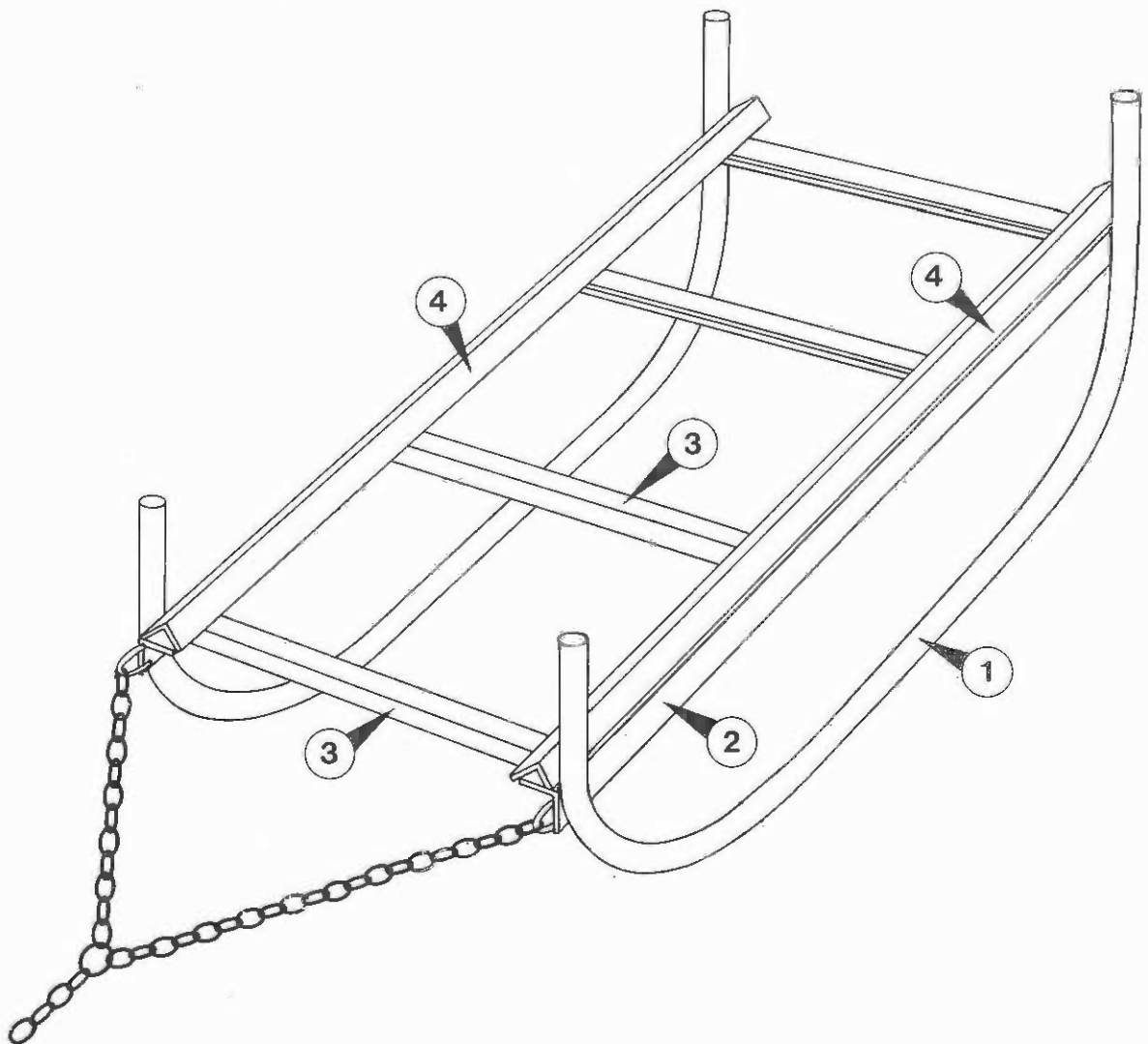

16. Log sledge 2

Use

To carry logs or short lengths of wood.

Material

4 pieces of pipe 50 mm \varnothing x 100 mm (1), 2 pieces of 2 mm channel iron 2 750 x 40 x 40 mm (2), 4 lag screws 13 mm \varnothing x 100 mm (3), 2 wooden runners 3 000 x 100 x 80 mm, rounded at both ends (4), 4 pieces of pipe 60 mm \varnothing x 150 mm (5), 2 pieces of 2 mm channel iron 1 000 x 60 x 40 mm (6), 4 pieces of pipe 50 mm \varnothing x 850 mm (7), 2 pieces of iron rod 13 mm \varnothing x 75 mm (8), a length of chain 5 mm \varnothing x 2 300 mm (9).

Instructions

Weld one of the four 100-mm pieces of pipe (1) to each end of the long pieces of channel iron (2). Drill two holes in these channels for the lag screws (3) and attach the channels to the runners (4). Weld one of the four 150-mm pieces of pipe (5) to each end of the short pieces of channel iron (6). These are sockets for the 850-mm pieces of pipe (7) to hold the load in place on the sledge. Weld the short iron rods (8) to the long channels to provide fasteners for load-binding chains or rope. Attach the pull chain as shown (9). When using this sledge, long logs are stacked lengthwise and short lengths of wood are stacked crosswise. This piece of equipment can be easily taken apart and moved from place to place.

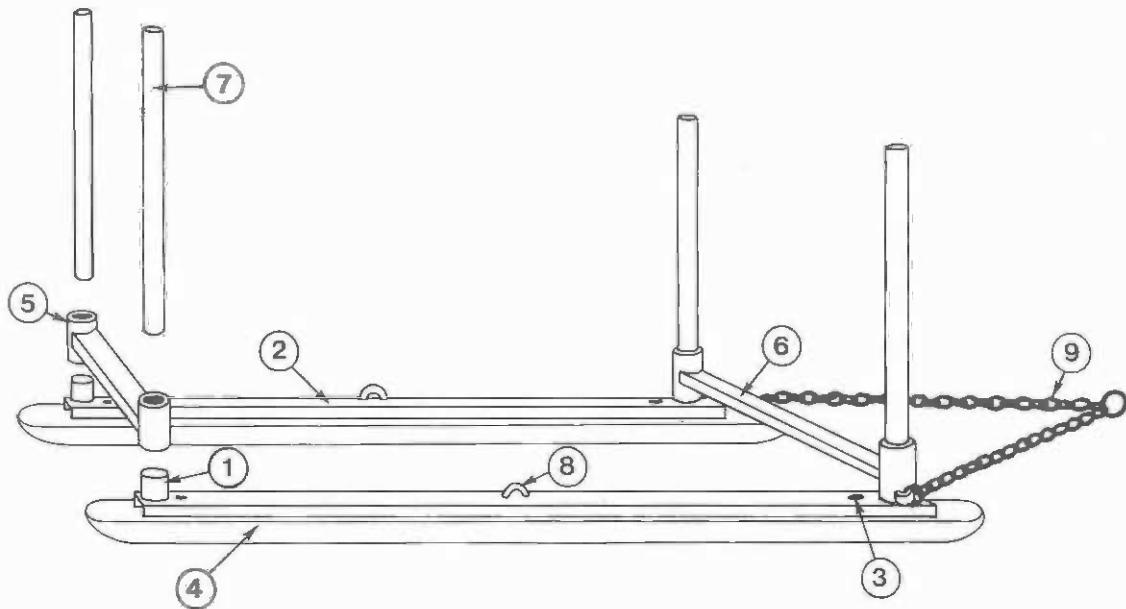

17. Wood pallet with runners

Use

To carry short lengths of wood over soft ground.

Material

2 pieces of pipe 80 mm \varnothing x 2 200 mm, for the pallet 4 pieces of iron rod 20 mm \varnothing x 1 000-1 500 mm and a small piece of iron 50 x 50 x 10 mm for the runners, 2 pieces of flat iron 1 500 x 250 x 10 mm and 4 pieces of 2-mm angle iron 1 000 x 50 x 50 mm, 3 lengths of heavy chain, a heavy ring and a wooden spreader 2 mm \varnothing x 800 mm for the pull.

Instructions

Heat and shape the two pieces of pipe and weld them together using the four iron rods to form the pallet. The width of the pallet can vary from 1 000 to 1 500 mm according to the length of wood to be carried. Weld the small piece of iron to the top iron rod at one end of the pallet and drill a hole in it for the pull chain. Heat and shape the two pieces of flat iron to form the runners and weld two pieces of angle iron to each of them. Drill a hole in the curved end of each runner and attach the pull chain as shown. The upper length of chain can be removed when the pallet is being loaded. The wooden spreader is used between the lower lengths of chain when only the runners are being pulled to keep them apart. The runners are placed parallel on the ground and a loaded pallet is pulled into place between the angles on the runners. This piece of equipment can be pulled by animals or by winch and cable.

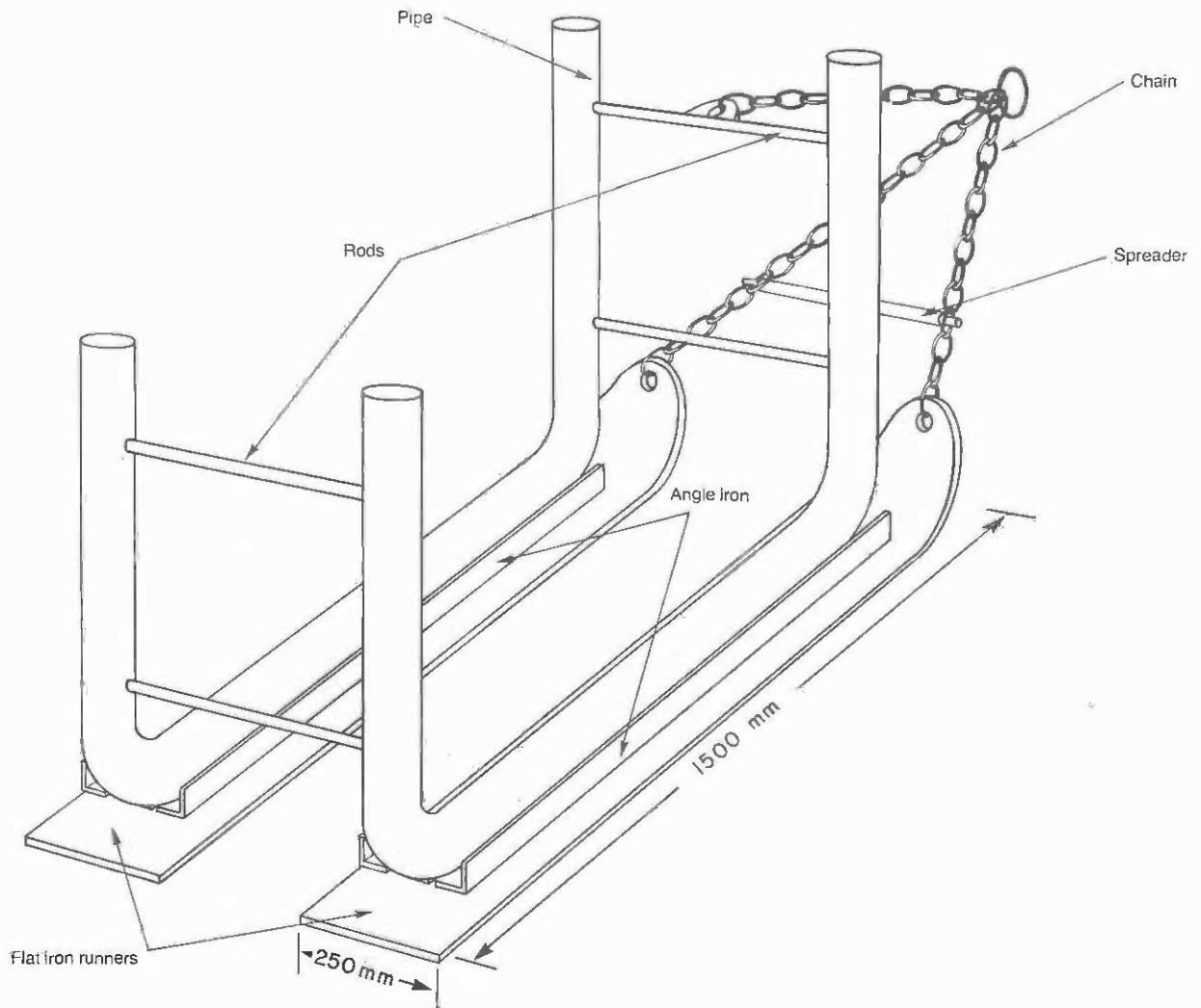

DESIGN MANUAL ON BASIC WOOD HARVESTING TECHNOLOGY

BOOKLET 4

PILING, LOADING AND TRANSPORT

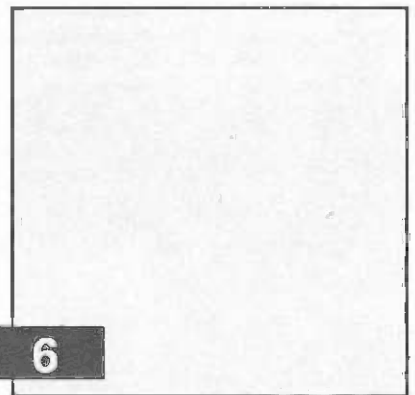
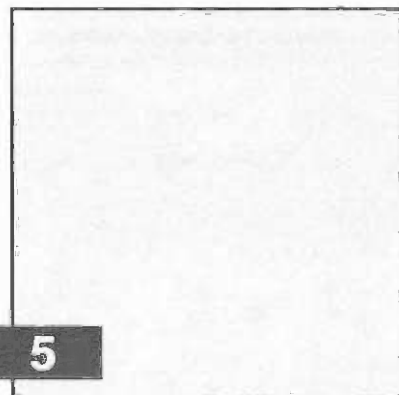
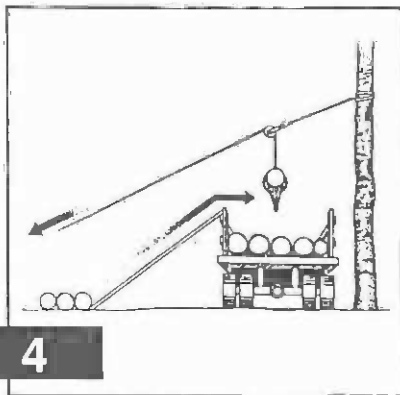
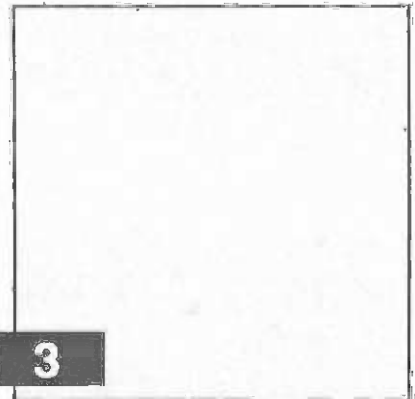
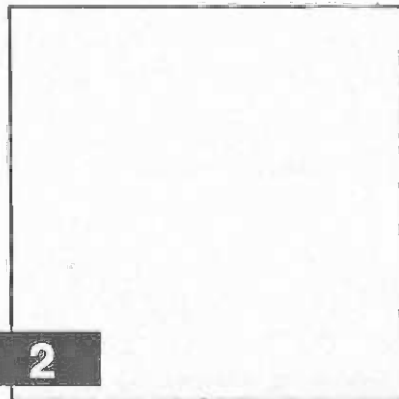
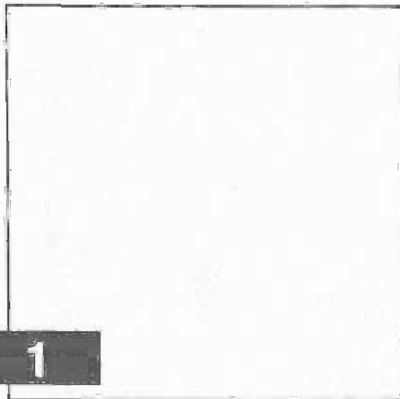

The designations employed and the presentation of material in this publication do not imply the expression of any opinion whatsoever on the part of the Food and Agriculture Organization of the United Nations concerning the legal status of any country, territory, city or area or of its authorities, or concerning the delimitation of its frontiers or boundaries.

M-39
ISBN 92-5-102537-1

All rights reserved. No part of this publication may be reproduced, stored in a retrieval system, or transmitted in any form or by any means, electronic, mechanical, photocopying or otherwise, without the prior permission of the copyright owner. Applications for such permission, with a statement of the purpose and extent of the reproduction, should be addressed to the Director, Publications Division, Food and Agriculture Organization of the United Nations, Via delle Terme di Caracalla, 00100 Rome, Italy.

© FAO 1989

Contents

1. Pulley block and cable loading 1
 2. Pulley block and cable loading 2
 3. Hand-winch
 4. A-frame for cross-hauling logs
 5. Guyed pole loading
 6. Loading pivot 1
 7. Loading pivot 2
 8. Log jack
 9. Skid beam
 10. Loading hooks
 11. Load binder 1
 12. Load binder 2
 13. Release tongs
 14. Unloading ramp
 15. Rafting dog
 16. Tractor cart
 17. Logging track
-

Symbols and abbreviations used

°	Degree (angle)	
∅	Diameter measurement	
kg	Kilogram	= 2.205 pounds (lb)
m	Metre	= 1.094 yards (yd)
mm	Millimetre	= 0.0394 inch (in)
%	Percentage	

Note

Additional valuable information on the kinds of tools shown in this booklet can be found in FAO Forestry Paper 36, *Basic Technology in Forest Operations* (ISBN 92-5-101260-1).

1. Pulley block and cable loading 1

Use

To load logs on trucks and carts.

Material

A pulley block, a short length of cable, a pair of log-loading tongs, a long length of cable.

Instructions

Attach the pulley block (1) to a tree using the short cable (2). Attach the log-loading tongs (3) to one end of the long cable and thread the other end through the pulley block. Attach the long cable to the source of power (4). You can adjust the chain or cable supporting the pulley so that it will be directly over the place where you want to drop the log on the truck or cart.

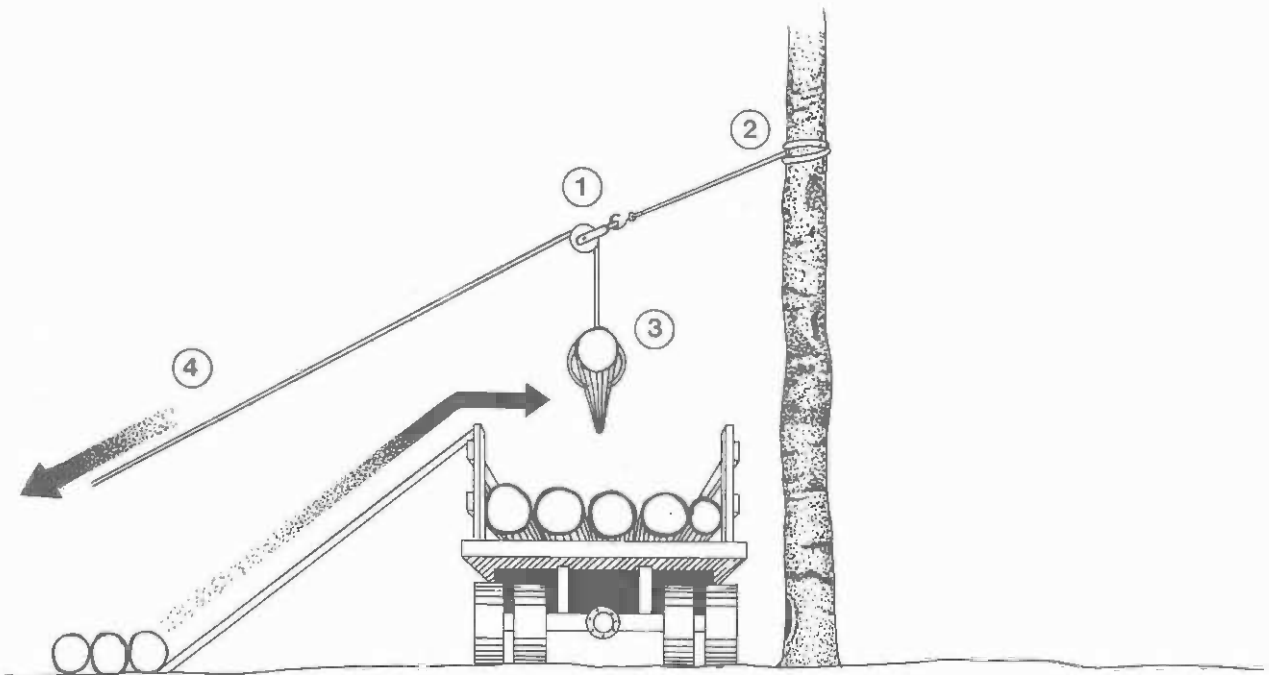

2. Pulley block and cable loading 2

Use

To load logs on to trucks and carts.

Material

Pulley blocks, rope or wire cable, 1 to 4 poles of suitable size.

Instructions

A single pole (1) or two poles in an A-frame well anchored to a tree (2) can be used to support the pulley blocks. If there are no trees, four free-standing poles can be used (3). Pulley blocks can be used in various combinations. The mechanical advantage will be equal to the number of strands supporting the movable pulley block. A spacer bar may be needed to keep the loops of the cables from moving in from the ends of the logs during loading.

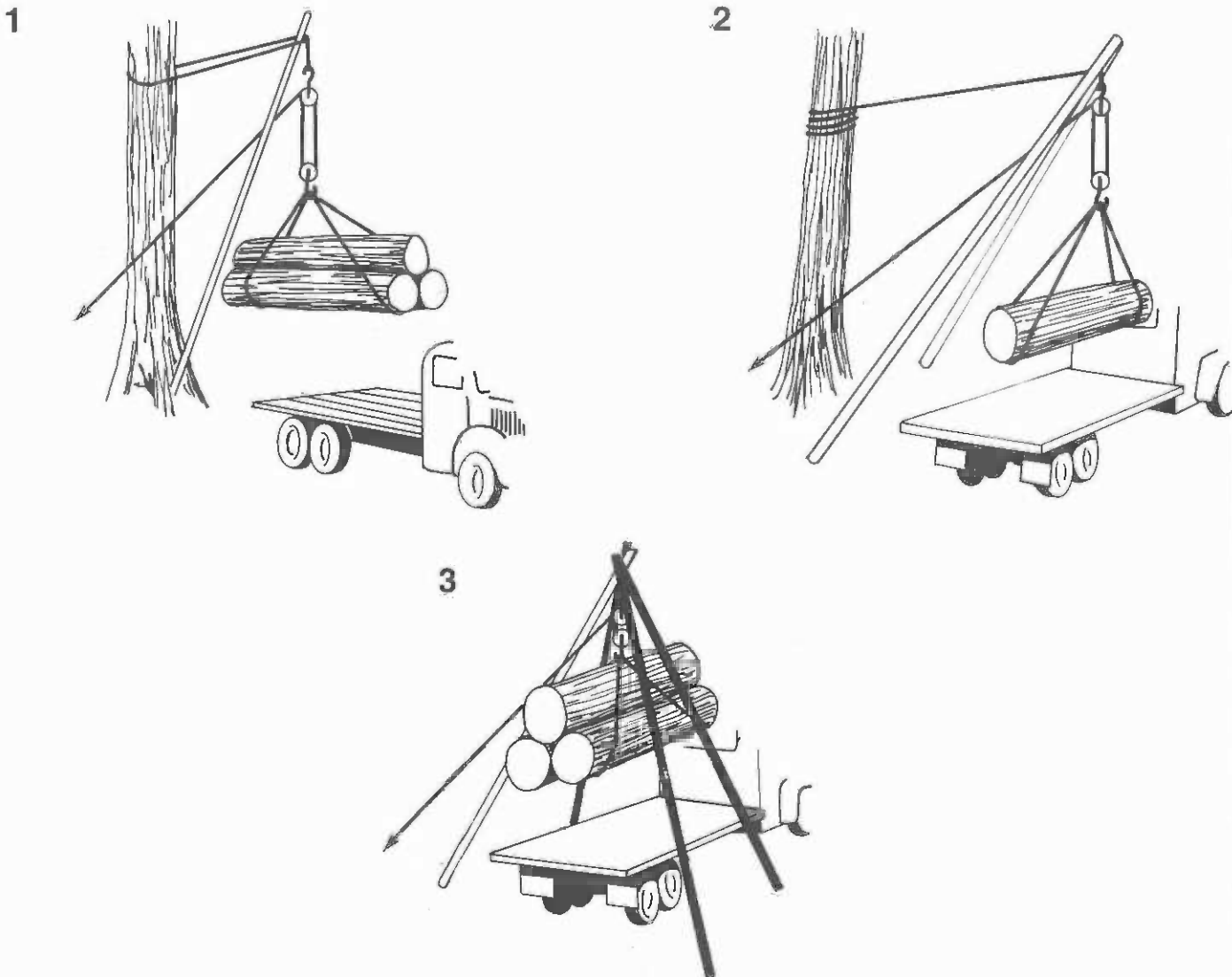

3. Hand-winch

Use

To supply power for hauling and lifting.

Material

1 flat iron bar 500 x 50 x 35 (crank), 1 iron rod 10 mm \varnothing x 350 mm (crank handle), rubber tube 10 mm \varnothing x 300 mm (handle cover), 2 pieces of iron 250 x 250 x 20 mm (flanges), 1 iron rod 30 mm \varnothing x 300 mm (axle), 1 piece of iron 320 x 200 x 5 mm (drum), 1 flat iron bar 40 x 25 x 10 mm (pawl), 1 rivet 10 mm \varnothing x 40 mm (pawl attachment), 2 flat iron bars 500 x 25 x 10 mm (side frames).

Instructions

Shape the flat iron bar to form the crank. Attach the crank handle and the rubber tube handle cover (1). Cut two circles for the flanges and notch one of them as shown (2). Shape the drum and weld on the flanges. Drill a hole through the centre of the flanges, insert the axle and weld it in place. File one end of the axle to fit the crank (3). Shape the two side frames with mounts for the axle and pawl. Rivet the pawl in place. The notches in one flange of the winch permit it to be turned in one direction only. The pawl keeps the winch from unwinding (4).

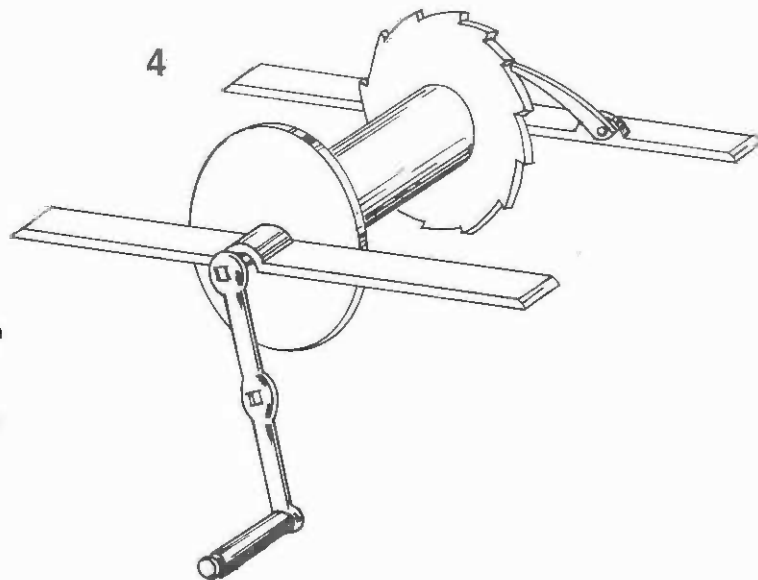
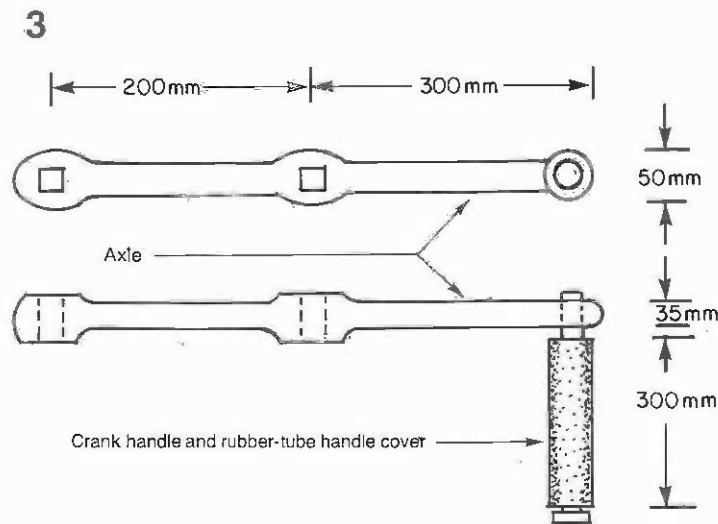
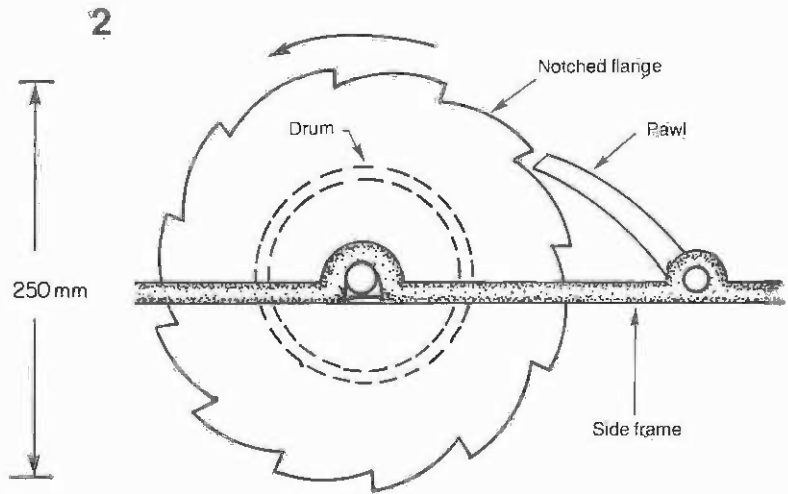
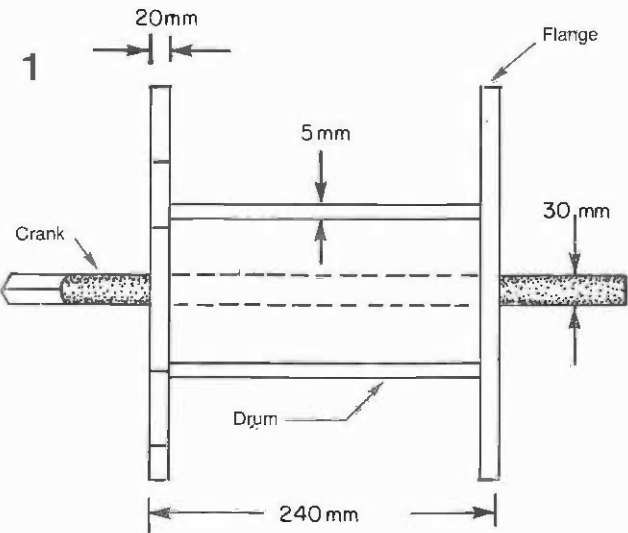

4. A-frame for cross-hauling logs

Use

To cross-haul logs on to the deck of a truck or trailer.

Material

Hardwood timbers of various sizes, a hand-winch with fittings (see Sheet 4 of this booklet), a length of rope or wire cable.

Instructions

Build the A-frame using the dimensions shown. A cable attached to the hand-winch is passed over and under the log to be hauled. The end of the cable is anchored to the inside of the truck deck. When the hand-winch is operated the log is hauled up the wooden plank incline to the deck of the truck or trailer.

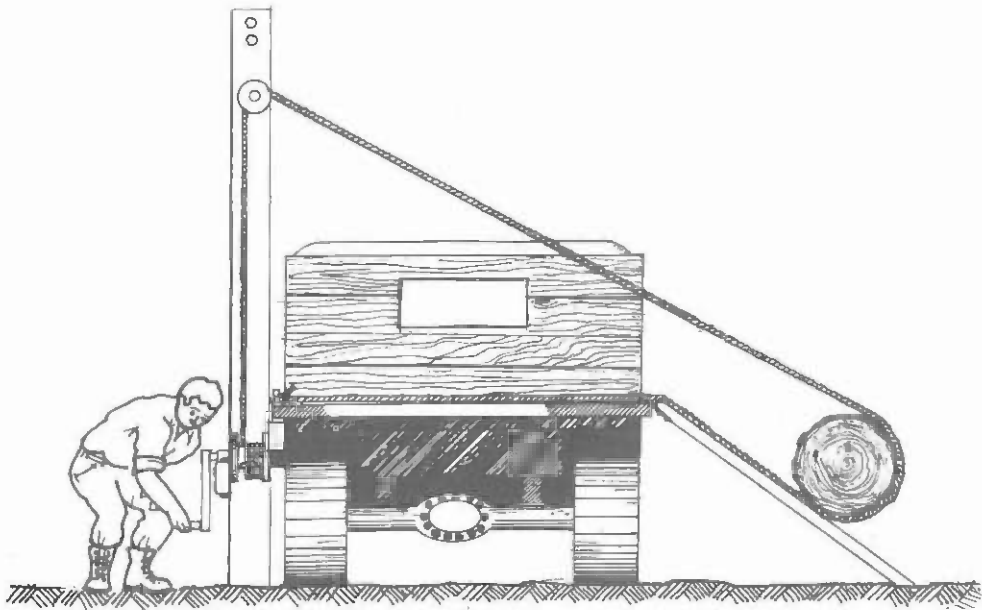

Front view

Side view

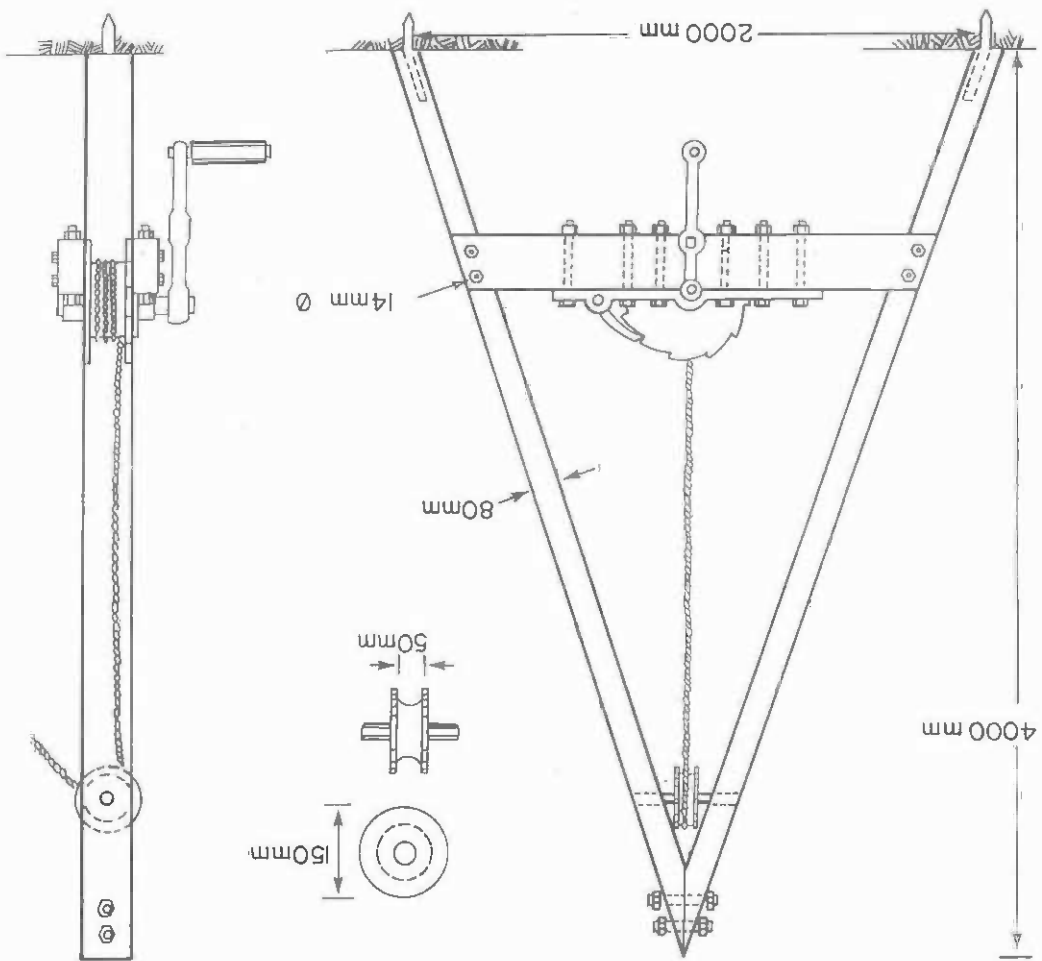

5. Guyed pole loading

Use

To lift logs for loading.

Material

A pole at least 150 mm \varnothing at the top and at least 10 m long, 1 iron bar 470 x 100 x 10 mm, 4 U-bolts, 3 pulley blocks, loading hooks and chains (see Sheet 10 of this booklet), cable.

Instructions

Shape the iron bar to form a collar around the top of the pole. Attach the four U-bolts to the collar. Three U-bolts are for the guy lines and the fourth is for a pulley block. Two other pulley blocks are required as shown. The movable and upper fixed pulley can be doubled to increase lifting capacity. The fixed pulley mounted on the pole serves to change the direction of the pull.

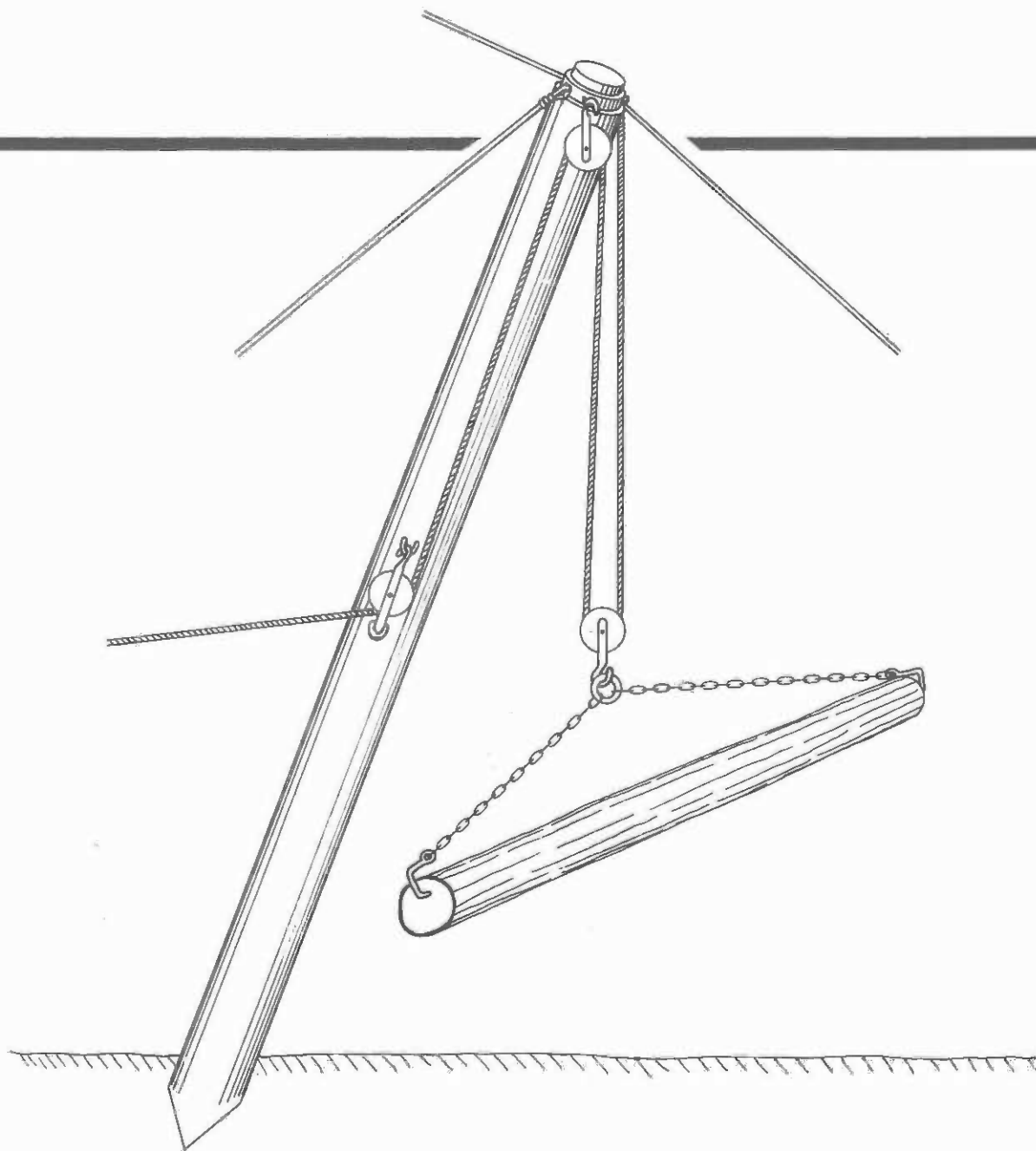

6. Loading pivot 1

Use
To load logs by hand.

Material
Used scrap pipe of varying diameters.

Instructions
Make a free-standing tripod with legs sufficiently spread to be stable. A yoke-shaped bracket is welded to a length of pipe that fits into the tripod. Drill holes in this pipe and insert a pin to adjust the height. Loading is done by placing a log on the yoke and then swinging it over on to the pile.

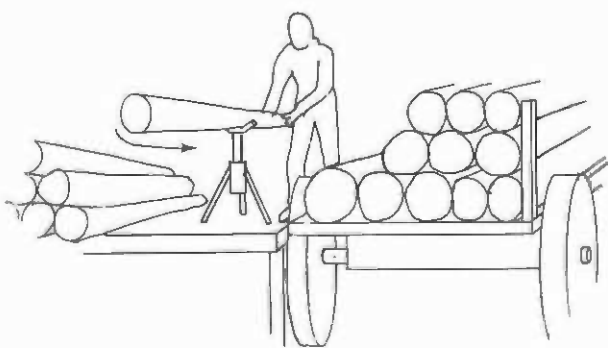
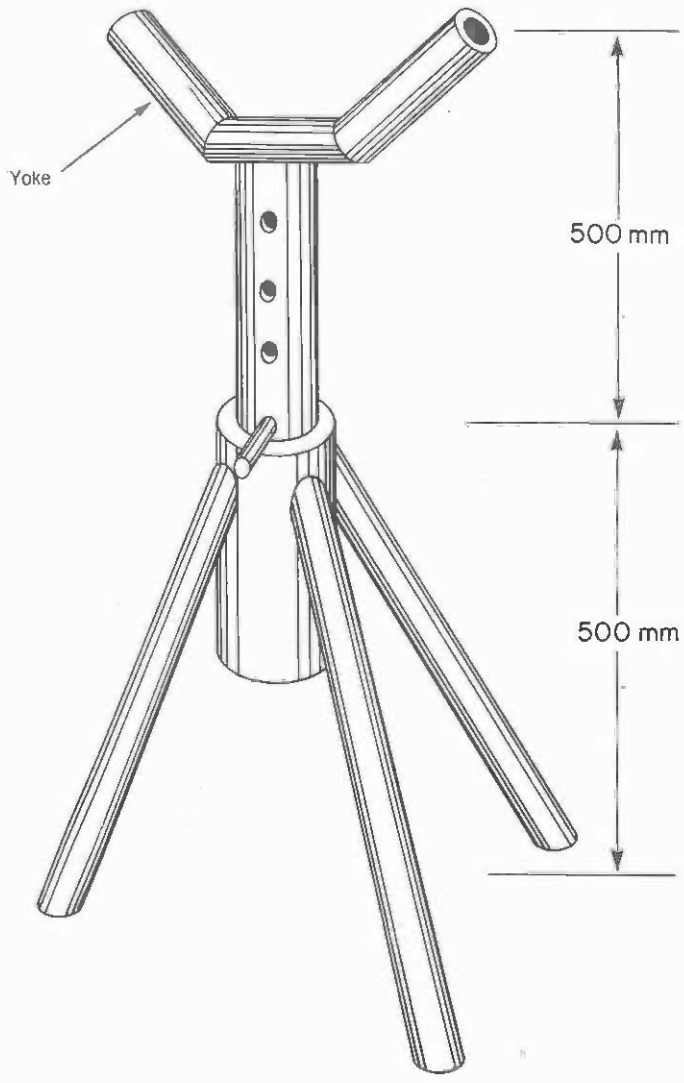

7. Loading pivot 2

Use

To load logs by hand.

Material

1 piece of flat iron 160 x 100 x 10 mm (1), 1 piece of flat iron 260 x 60 x 10 mm (2), 1 piece of flat iron 350 x 60 x 10 mm (3).

Instructions

Shape the top piece (1) and the curved upright (3) using the dimensions below. Cut the notches as shown. Weld the three pieces together with the cross-arm (2) at a 90° angle to the upright. Hook the rounded part of the tool to a log in the middle of the pile. Loading is done by placing a log on the pivot and then swinging it over on to the pile.

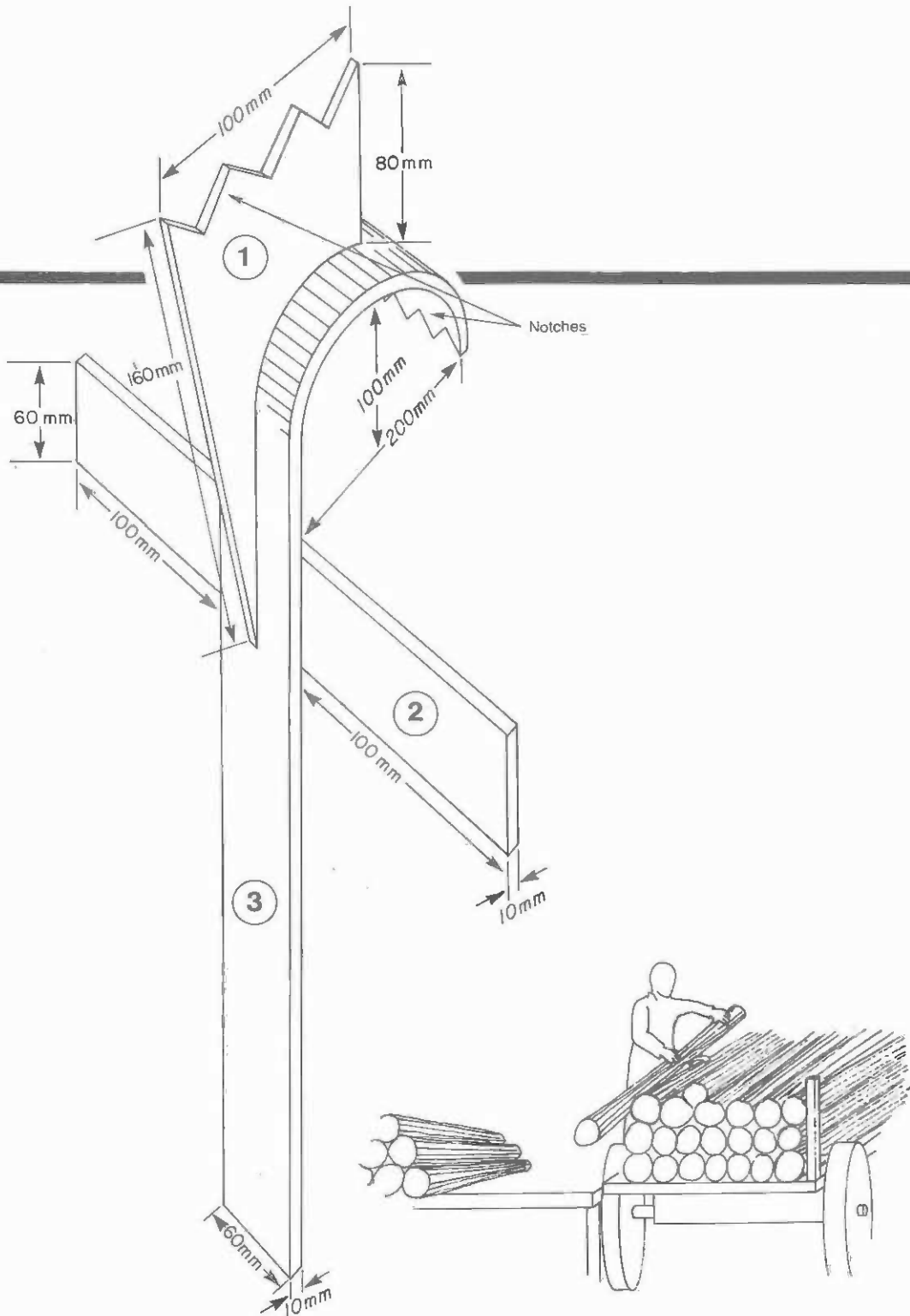

8. Log jack

Use

To pile logs by hand.

Material

1 or 2 logs about 150 mm Ø x 3 600 mm.

Instructions

Chop or saw steps 50-60 mm deep and about 400 mm high in each log as shown (1). One person can use one log jack to pivot medium-sized logs on to a pile (2). If the logs are large, two people and two log jacks may be necessary (3).

1

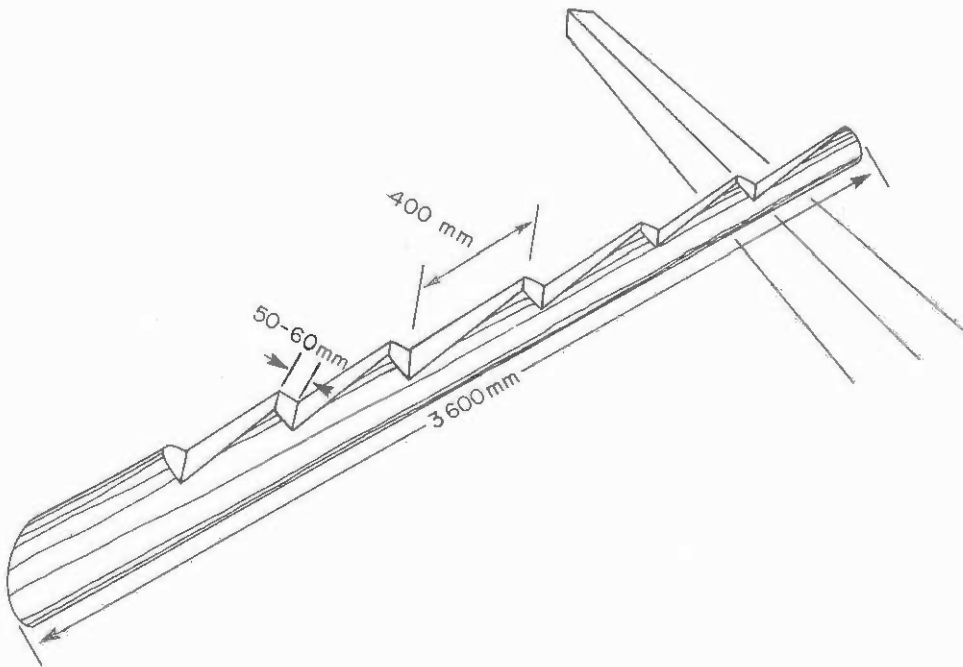

2

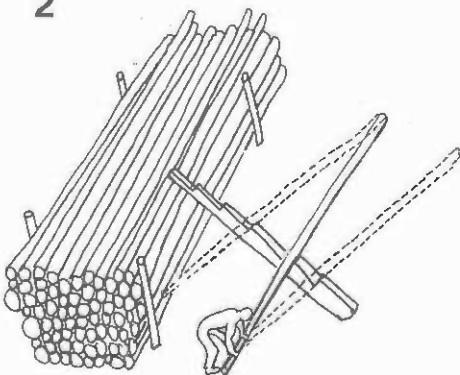

3

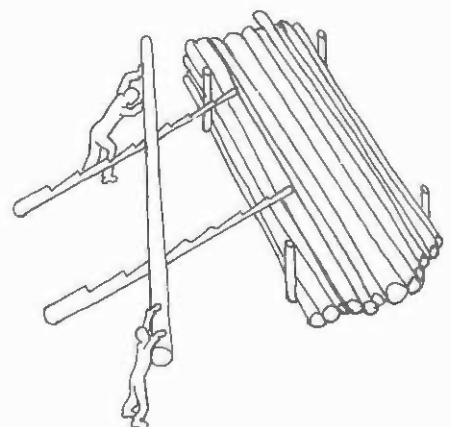

9. Skid beam

Use

To roll logs on to piles, trucks or carts.

Material

2 timber beams 100 x 100 mm and of suitable length,
2 pieces of flat iron 160 x 100 x 10 mm, 6 screws 50 mm
long.

Instructions

Round off one end of each beam. Shape the two pieces of flat iron to form the beam shoes using the dimensions below. Screw the shoes to the underside of the beams. Place the two beams on the pile or load (the shoes will keep the beams from slipping) and roll on the logs.

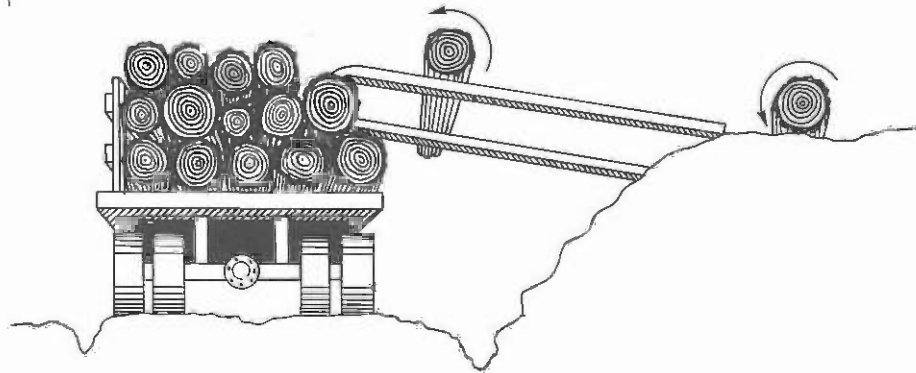
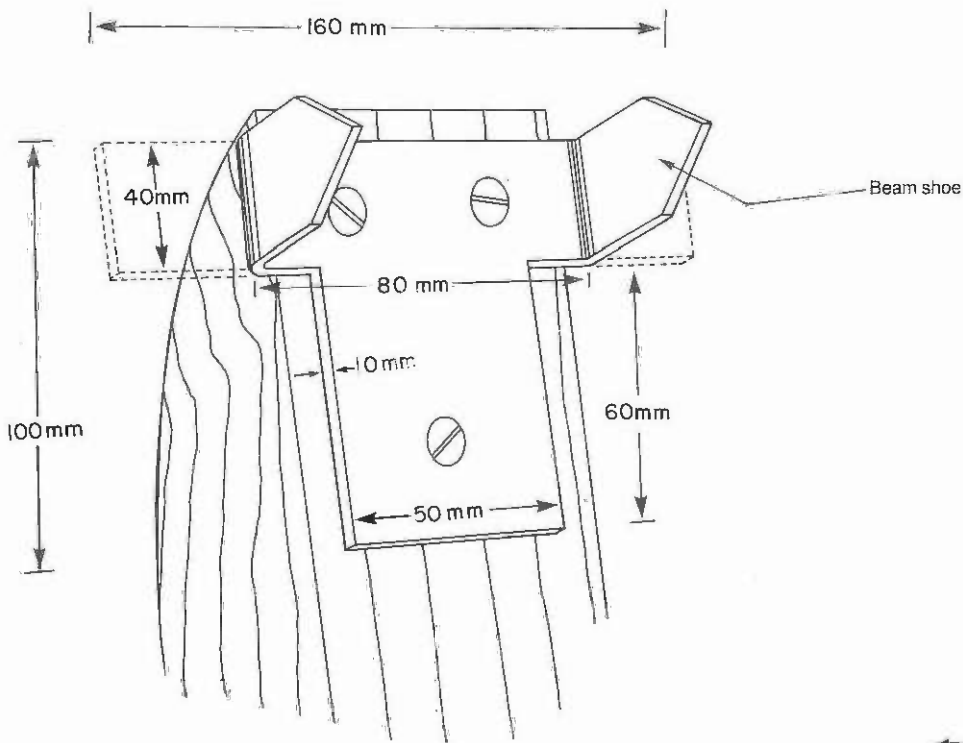

10. Loading hooks

Use

To lift logs for loading.

Material

2 iron rods 30 mm Ø x 520 mm, 2 iron rods 20 mm Ø x 230 mm, 2 lengths of chain.

Instructions

Heat and bend the longer rods to form two hooks with eyes using the dimensions below. Sharpen and harden the points. Heat and bend the short rods and form a ring about 60 mm Ø in the eye of each hook. Loading hooks are used to lift a log by both ends from a central point such as a loading crane or boom. Tension in hooks, chains or cables will vary with the angle formed with the log. The table below gives conversion factors for various angles. The example below shows how to use a conversion factor to calculate tension in a lifting arm.

Angle of chain or cable	Conversion factor
90°	0.50
70°	0.53
45°	0.71
30°	1.00
20°	1.00

Example

A log weighing 400 kg is raised by hooks forming a 45° angle with the log. The conversion factor for a 45° angle is 0.71. Then, $400 \text{ kg} \times 0.71 = 284 \text{ kg}$ (the load in each hook, chain or cable).

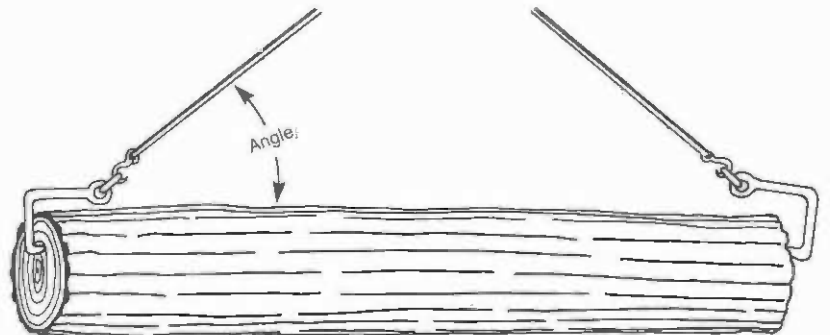
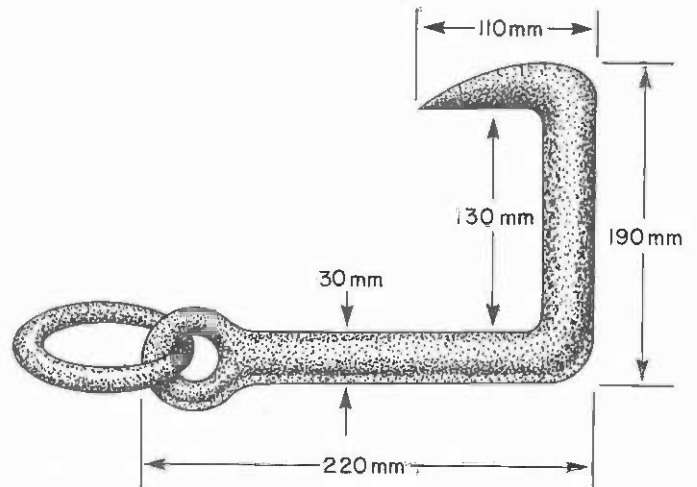

11. Load binder 1

Use

To anchor loaded logs for transport.

Material

1 piece of flat iron 500 x 40 x 5 mm (1), 1 piece of flat iron 300 x 40 x 5 mm (2), 1 piece of flat iron 450 x 40 x 5 mm (3), 2 bolts 10 mm \varnothing x 25 mm with nuts, 3 rings with chain hooks (4), 4 washers, 1 metal pin (5), a length of chain.

Instructions

Make the top of the binder by folding the long piece of flat iron double (1). Make an elbow by folding the short piece of flat iron double (2), then heat and bend it at the centre to an angle of 120° . Make the handle by heating and bending the remaining piece of iron to an angle of 120° at a point about one fourth of the way up from its inside end (3). Drill two holes and bolt the three pieces together with the rings and hooks in place as shown (4). The binder will open and close more easily with washers threaded on to the bolts on each side of the handle. Close the binder and drill a hole through the handle and the top piece for the lock pin (5). The pin is used to keep the binder closed when not in use. To use the binder, wrap the chain around the load, attach the hooks to the chain and pull the chain tight by closing the handle. If the load is too loose, open the handle and hook the next link of the chain. Then close the handle again.

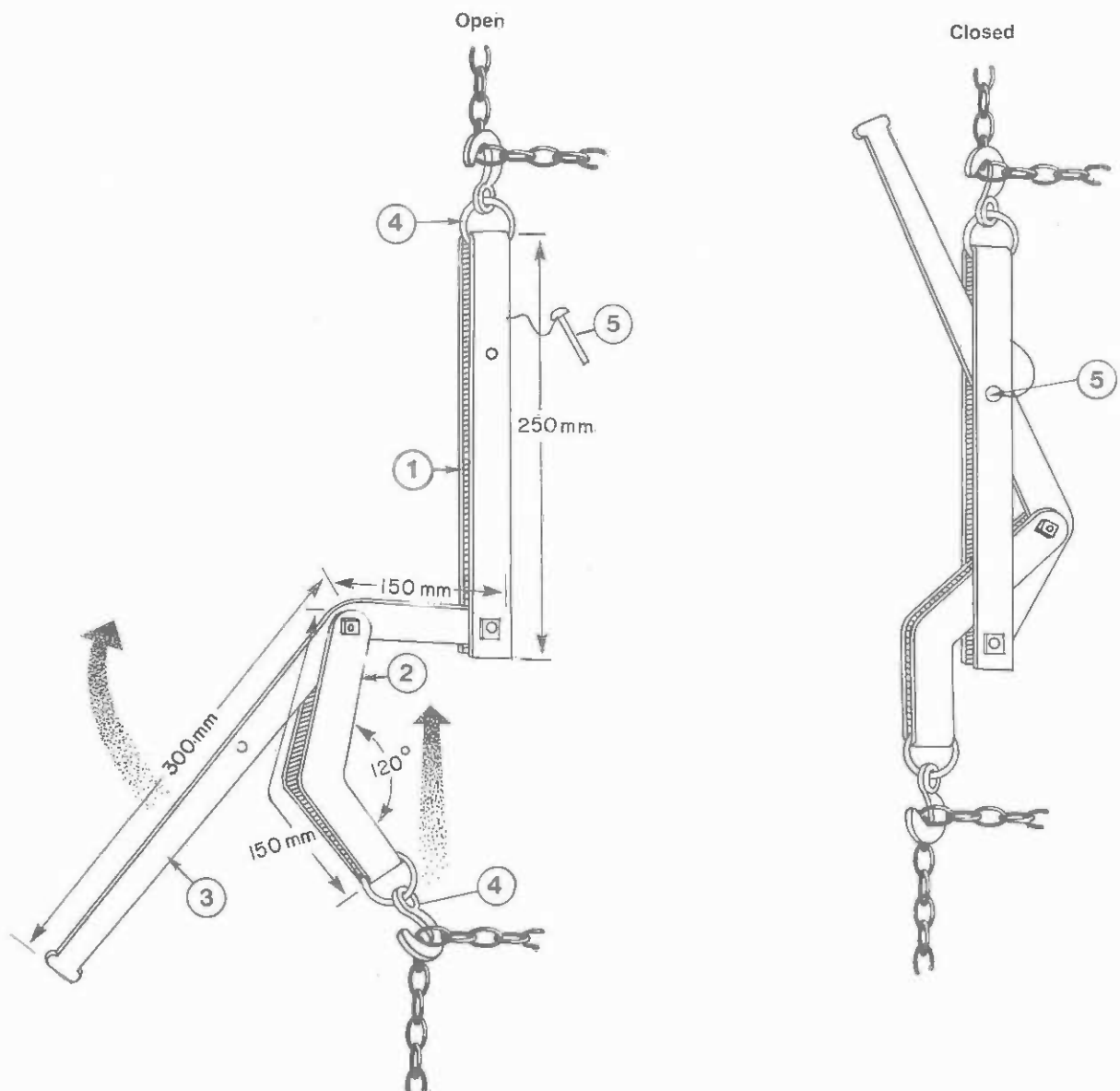

12. Load binder 2

Use

To anchor loaded logs for transport,

Material

3 pieces of flat iron 150 x 25 x 5 mm, 1 iron rod 5 mm Ø x 100 mm, 1 bolt with nut or 1 rivet.

Instructions

Make the two bottom pieces (1) and the handle (2) of the binder as shown by heating and bending. Drill two holes through both bottom pieces for the rope and for the lock pin. Assemble the three pieces with a bolt or a rivet. Heat and bend the iron rod and form a ring of about 25 mm Ø in the ring hole. Attach one end of the rope to the hole in the bottom and make a loop on the other end to hook over the handle. Close the handle to pull the load tight and lock it with the ring. This binder can be released quickly under strain.

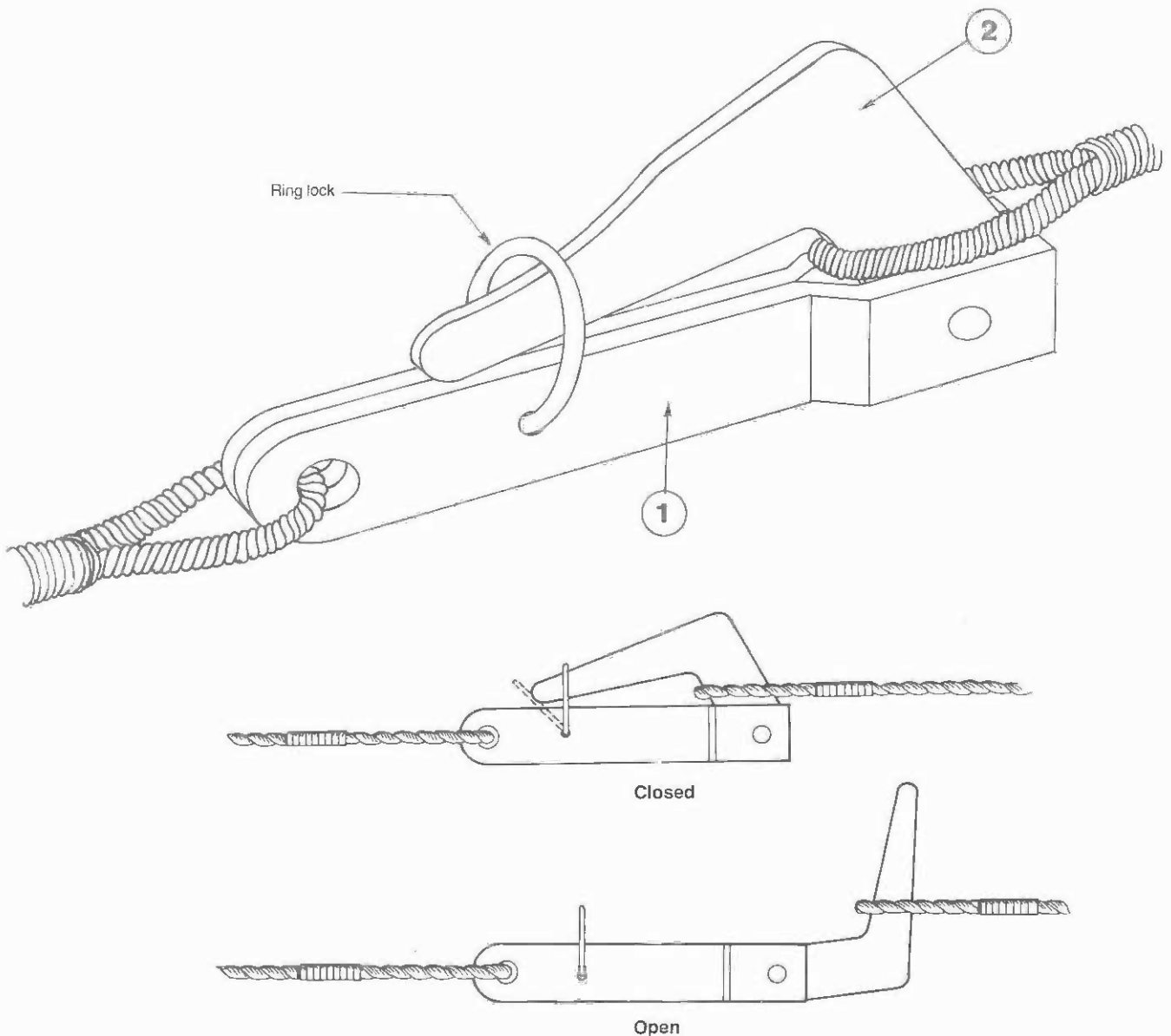

13. Release tongs

Use

To quickly release loads of logs.

Material

A pair of log tongs (see Sheet 5, Booklet 2), 1 iron bar 200 x 15 x 15 mm, 1 iron rod 5 mm Ø x 120 mm, a pulley block with ring, rope.

Instructions

Heat and shape an eye on one end of the iron bar and weld the other end to the top of one tong hook (1). Heat and shape the iron rod to form a small ring and weld it to the lower end of the other tong hook (2). Attach the pulley block (3), tie the rope to the ring and thread the rope through the pulley. A pull on the rope will unhook the tongs. This device can eliminate the need for a person on top of the load and allow control of swinging empty tongs.

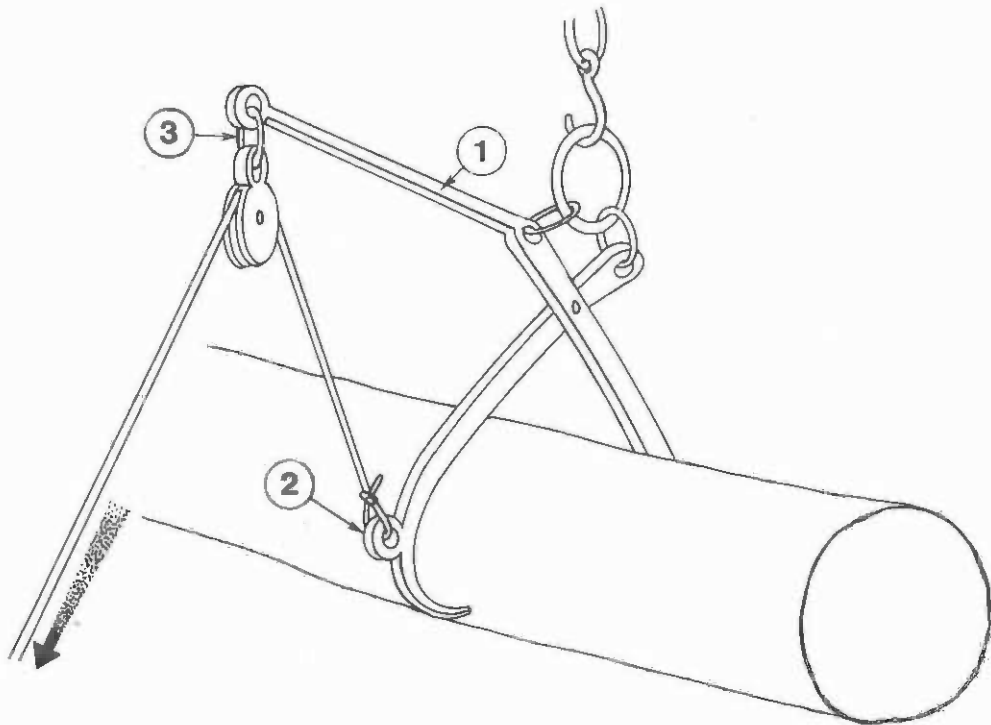

14. Unloading ramp

Use

To unload a log truck by gravity.

Material

Heavy hardwood boards at least 500 mm thick.

Instructions

Build a double ramp like the one shown in the diagram. The length and width will depend on whether the truck to be used has single or dual wheels and single or tandem axles. The dimensions shown are for double-axle, single-wheel trucks. To use the ramp, back one of the rear wheels on to it to tilt the truck to one side. When the side stakes on the truck deck are removed the logs will roll off through the force of gravity.

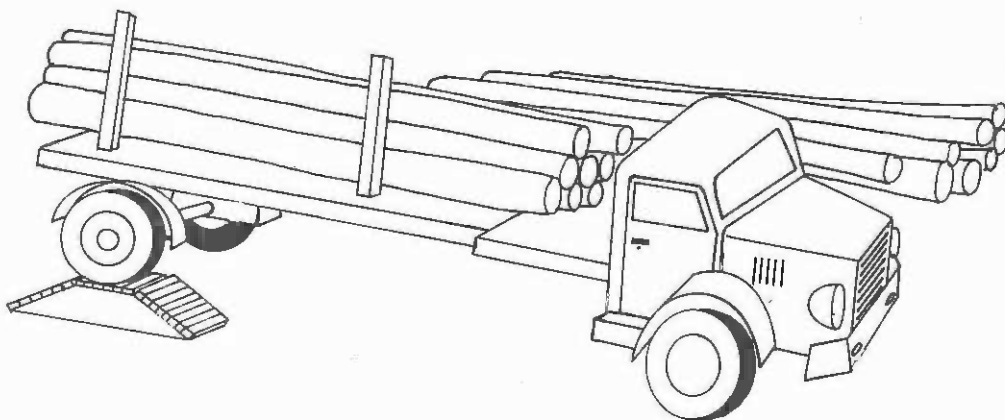
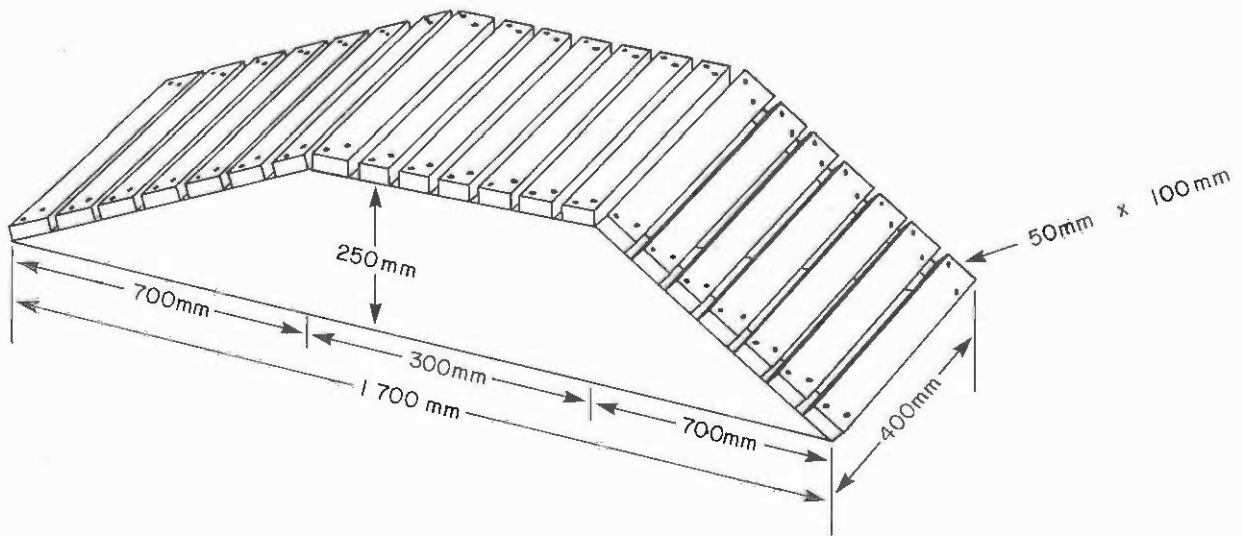

15. Rafting dog

Use

To attach a binding or towing rope or cable to a log.

Material

1 piece of flat iron 130 x 55 x 30 mm, 1 piece of iron rod 10-15 mm \varnothing x 160-170 mm.

Instructions

Shape the iron rod to form a ring about 40 mm \varnothing . File or grind the flat piece of iron to form the blade of the rafting dog using the dimensions shown. Round out the top surface of the blade and weld the ring to it. To use this tool pound the dog into a log near the upper end and pass the rope or cable through the ring.

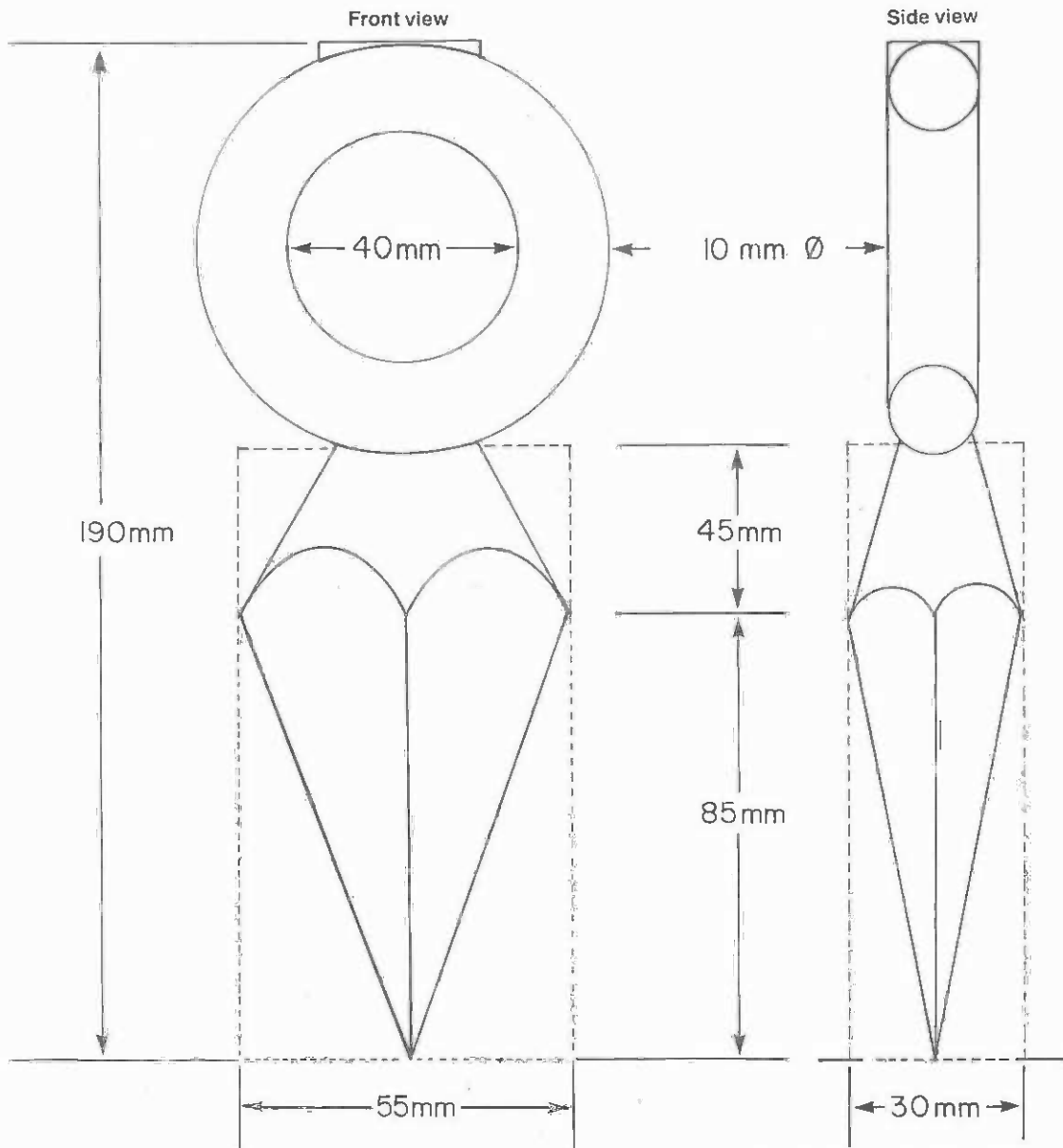

16. Tractor cart

Use

To haul logs, lumber and other loads.

Materials

Rear end of old car or truck chassis with driveshaft, axle, wheels and tires. 2 pieces of 10-mm angle iron 100 x 100 x 250 mm, 2 pieces of pipe 25 mm Ø x 1 100 mm, 2 square timbers 100 x 100 mm x the required length (2 500 mm in this example), 6 bolts 10 mm Ø x 120 mm with nuts, 2 pieces of wood 80 x 100 x 1 500 mm, 4 pieces of pipe 60 mm Ø x 1 500 mm, 2 pieces of iron 10 x 60 x 300 mm, 1 metal pin 20 mm Ø.

Instructions

Weld the two pieces of angle iron to the axles (1). Weld the two pieces of pipe from the driveshaft to the axle as braces (2). Bolt the square timbers to the angles for the main frame of the cart (3). Attach the two shorter pieces of wood (4) to the front and back of the timber frame and the four pieces of pipe to each corner (5) to hold the load. Make a hitch using the two small pieces of iron and the metal pin as shown in the detail.

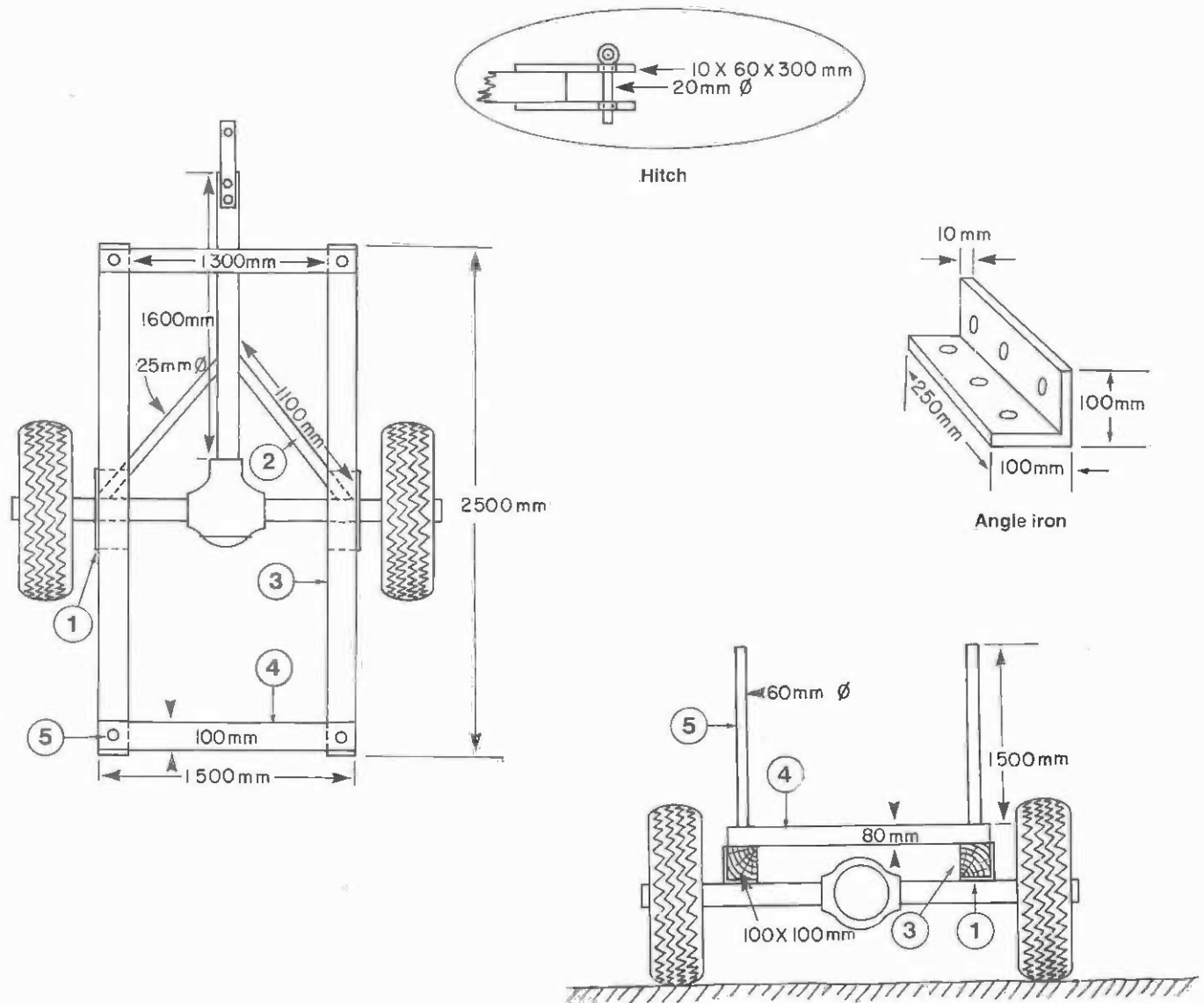

17. Logging track

Use

To allow carts and trucks to operate on soft ground.

Material

For each section of track you will need about 10 pieces of hardwood 600 x 200 x 40 mm, 2 steel straps 20 x 5 mm of appropriate length, 1 steel rod or 1 piece of pipe 20 mm \varnothing x 600 mm, 4 pieces of iron rod 5 mm \varnothing x 150 mm, nails or screws.

Instructions

Lay out the hardwood boards side by side on the ground with about 20 mm between each board. Bend the two steel straps so that they wrap around the bottom of both end boards and form a loop on each end as shown. Drill holes in the steel straps and the boards (four for each board) and nail or screw the straps and the boards together. Assemble the logging track by threading the long steel rod or the piece of pipe through the loops of two sections of track. Drill holes in both ends of the rod or pipe. Bend the ends of the shorter pieces of iron rod to form stakes as shown. Drive the stakes through the holes in the rod or pipe and into the ground to hold the track in place.

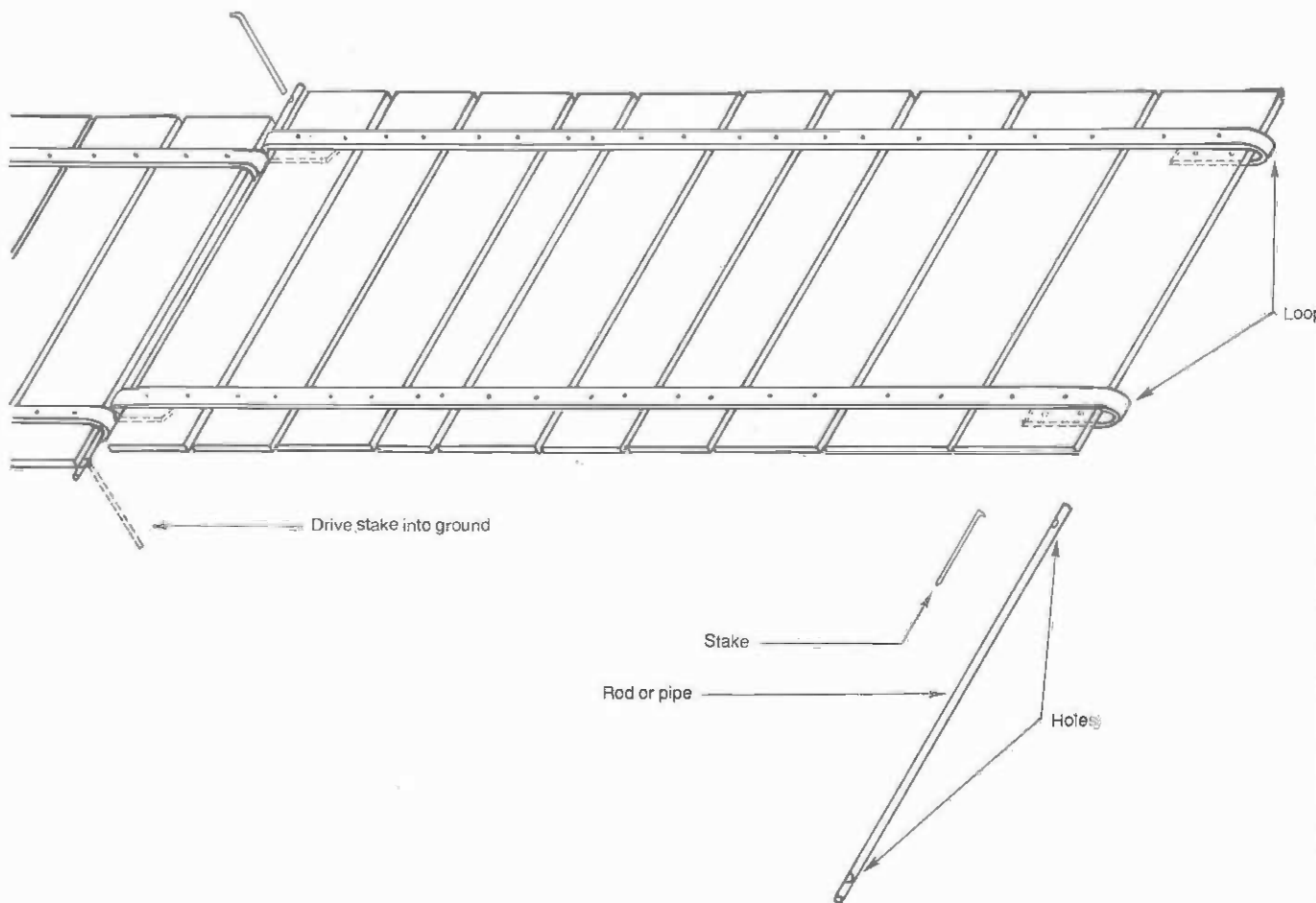

DESIGN MANUAL ON BASIC WOOD HARVESTING TECHNOLOGY

BOOKLET 5

WOOD HANDLING, BARKING,
SAWING AND SPLITTING

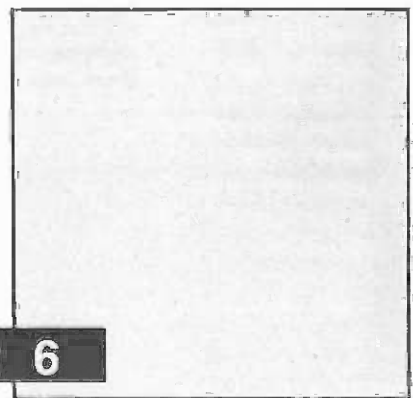
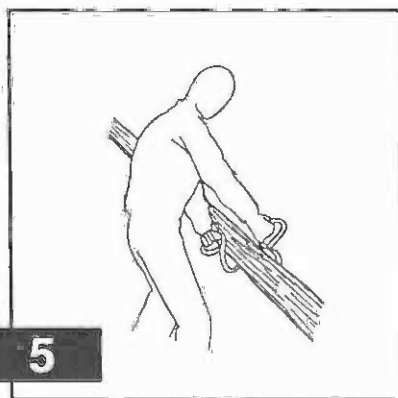
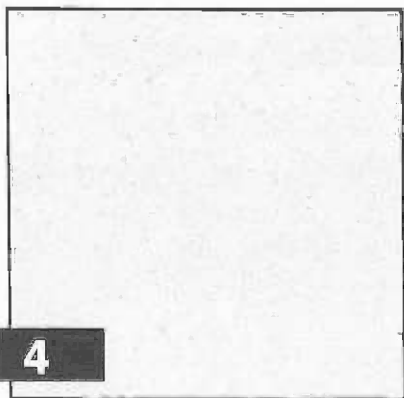
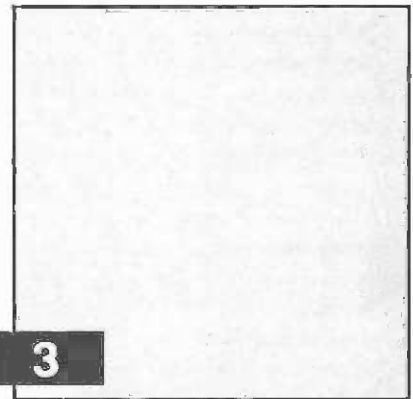
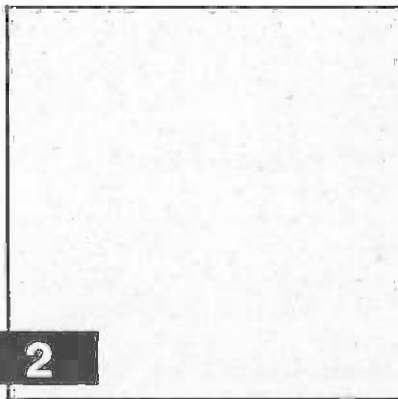
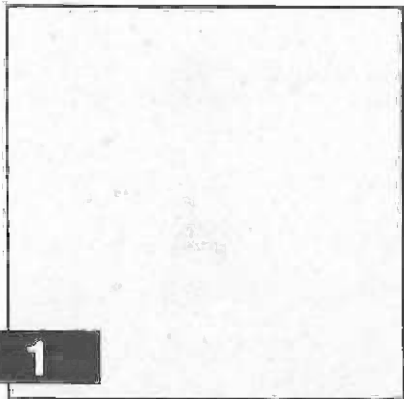

The designations employed and the presentation of material in this publication do not imply the expression of any opinion whatsoever on the part of the Food and Agriculture Organization of the United Nations concerning the legal status of any country, territory, city or area or of its authorities, or concerning the delimitation of its frontiers or boundaries.

M-39
ISBN 92-5-102537-1

All rights reserved. No part of this publication may be reproduced, stored in a retrieval system, or transmitted in any form or by any means, electronic, mechanical, photocopying or otherwise, without the prior permission of the copyright owner. Applications for such permission, with a statement of the purpose and extent of the reproduction, should be addressed to the Director, Publications Division, Food and Agriculture Organization of the United Nations, Via delle Terme di Caracalla, 00100 Rome, Italy.

© FAO 1989

Contents

1. Hand hook 1
 2. Hand hook 2
 3. Hand hook 3
 4. Hand hook 4
 5. Pickaroon
 6. Sappie
 7. Using a pickaroon or a sappie
 8. Cant hook 1
 9. Cant hook 2
 10. Cant hook 3
 11. Pike and log hook
 12. Firewood press
 13. Stump spike 1
 14. Stump spike 2
 15. Barking tool 1
 16. Barking tool 2
 17. Barking tool 3
 18. Pit or trestle sawing
 19. Pit or trestle saw
 20. Splitting maul
 21. Splitting wedge
 22. Splitting blade and mallet
 23. Wooden hammer 1
 24. Wooden hammer 2
-

Symbols and abbreviations used

°	Degree (angle)	
∅	Diameter measurement	
kg	Kilogram	= 2.205 pounds (lb)
m	Metre	= 1.094 yards (yd)
mm	Millimetre	= 0.0394 inch (in)
%	Percentage	

Note

Additional valuable information on the kinds of tools shown in this booklet can be found in FAO Forestry Paper 36, *Basic Technology in Forest Operations* (ISBN 92-5-101260-1).

1. Hand hook 1

Use

To lift, turn, drag or load small logs.

Material

A piece of iron rod 15 mm \varnothing x 450 mm or a piece of concrete reinforcing rod 15 mm \varnothing x 750 mm.

Instructions

Bend and weld the rods to form these two hooks using the dimensions shown below. Sharpen and harden the points.

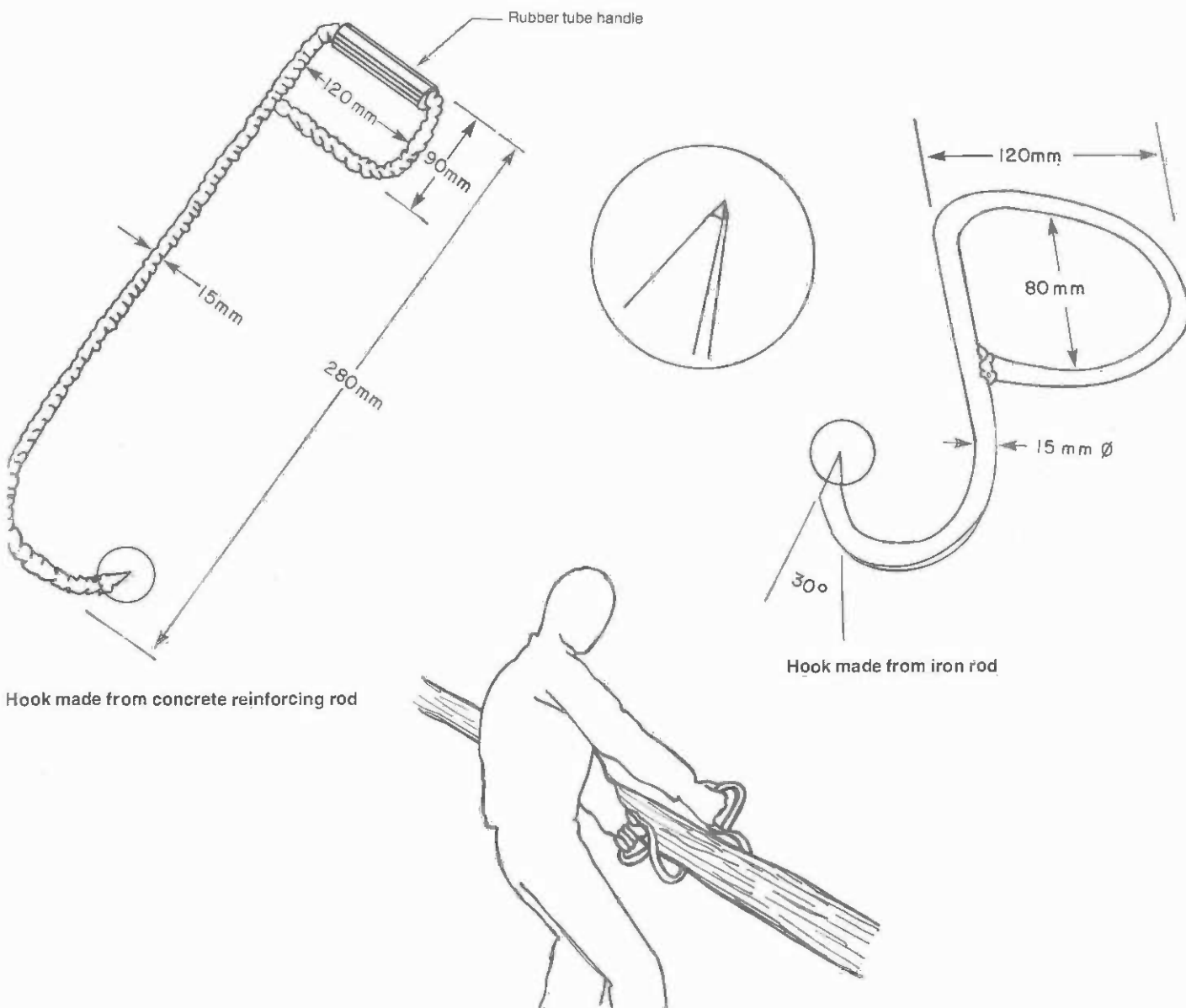

2. Hand hook 2

Use

To lift, turn, drag or load small logs.

Material

1 piece of iron 280 x 20 x 5 mm (hook), 1 piece of iron 230 x 20 x 5 mm (handhold), 1 iron pin 10 mm Ø x 120 mm (handle), 1 piece of wood or rubber (handle cover).

Instructions

Shape the hook and the handhold as shown and weld the two together. Sharpen and harden the point. Attach the handle.

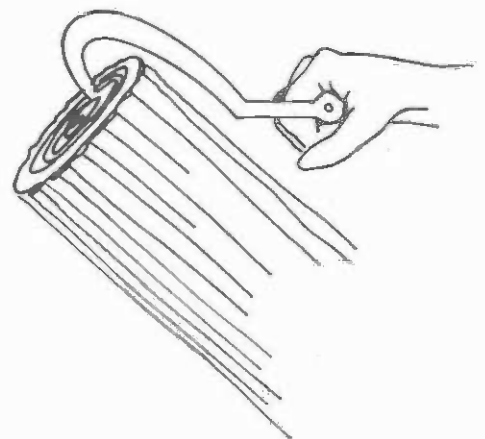
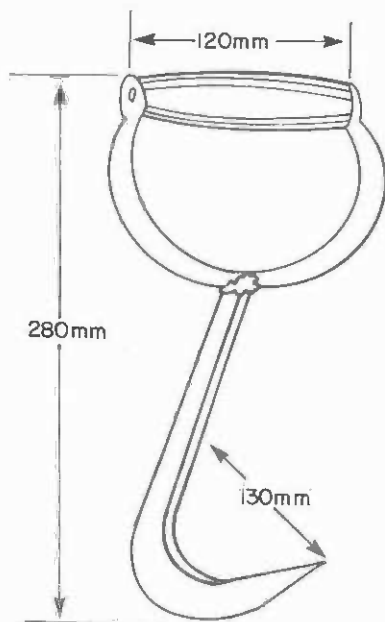

3. Hand hook 3

Use
To lift, turn, drag or load small logs.

Material
A piece of used axe handle or similar, 2 pieces of soft iron 65 x 30 x 3 mm, 1 bolt 10 mm Ø x 85 mm with nut.

Instructions
Shape the two pieces of soft iron over the end of the handle to form handle covers as shown. Drill a hole through both covers and the handle and draw them tightly together with the bolt. Grind or file the end of the bolt to a point and bend it slightly to form a hook. Harden the point of the hook.

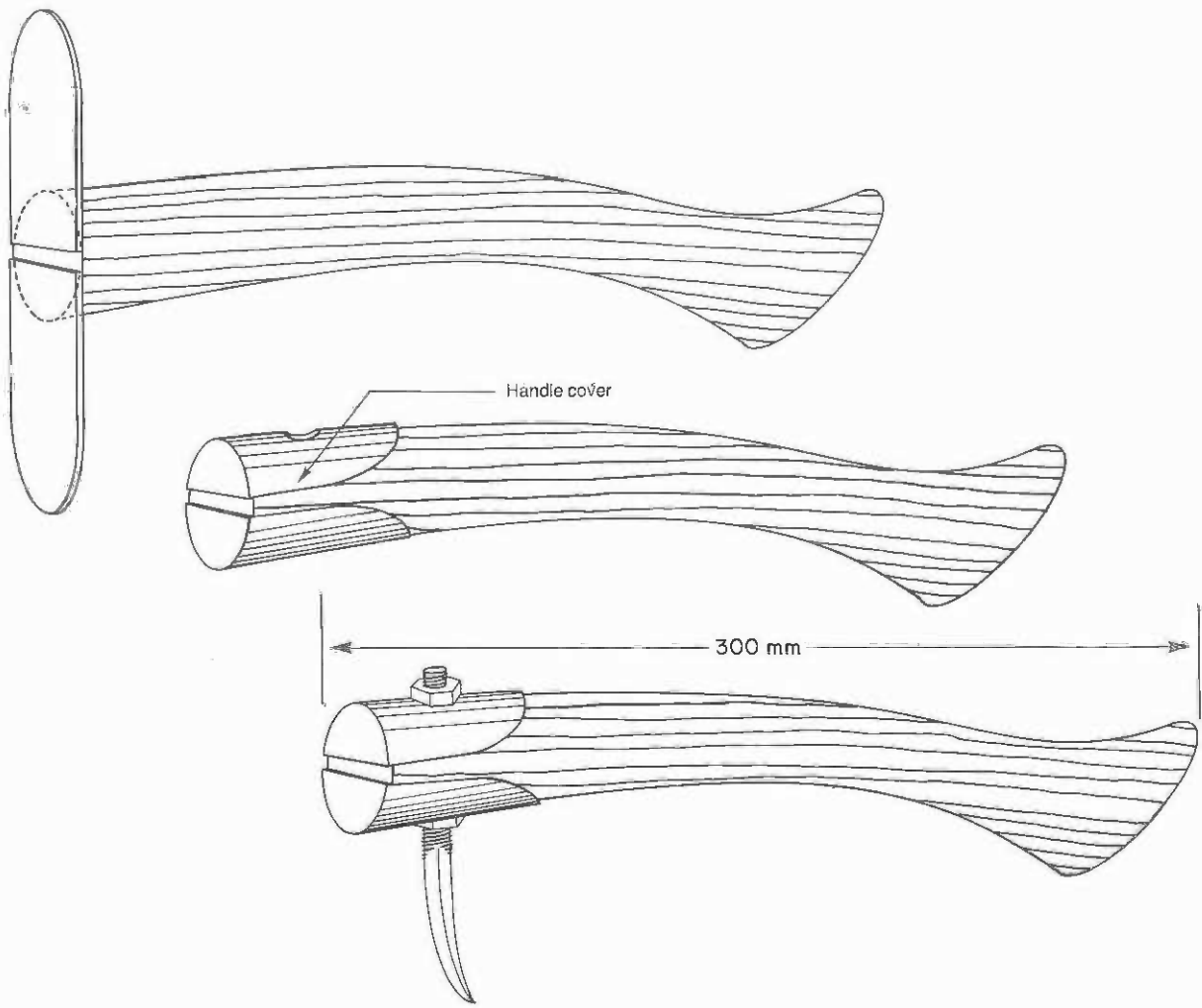

4. Hand hook 4

Use

To lift, turn, drag or load small logs.

Material

A piece of used axe handle or similar, 1 piece of flat carbon steel 170 x 30 x 4 mm, 1 bolt 10 mm \varnothing x 40 mm with nut, a ring of mild steel of appropriate diameter.

Instructions

Shape the piece of steel, file one end to a point and drill a hole in the other end as shown (1). Drill a hole in the handle and attach the hook with the bolt (2) and the steel ring (3).

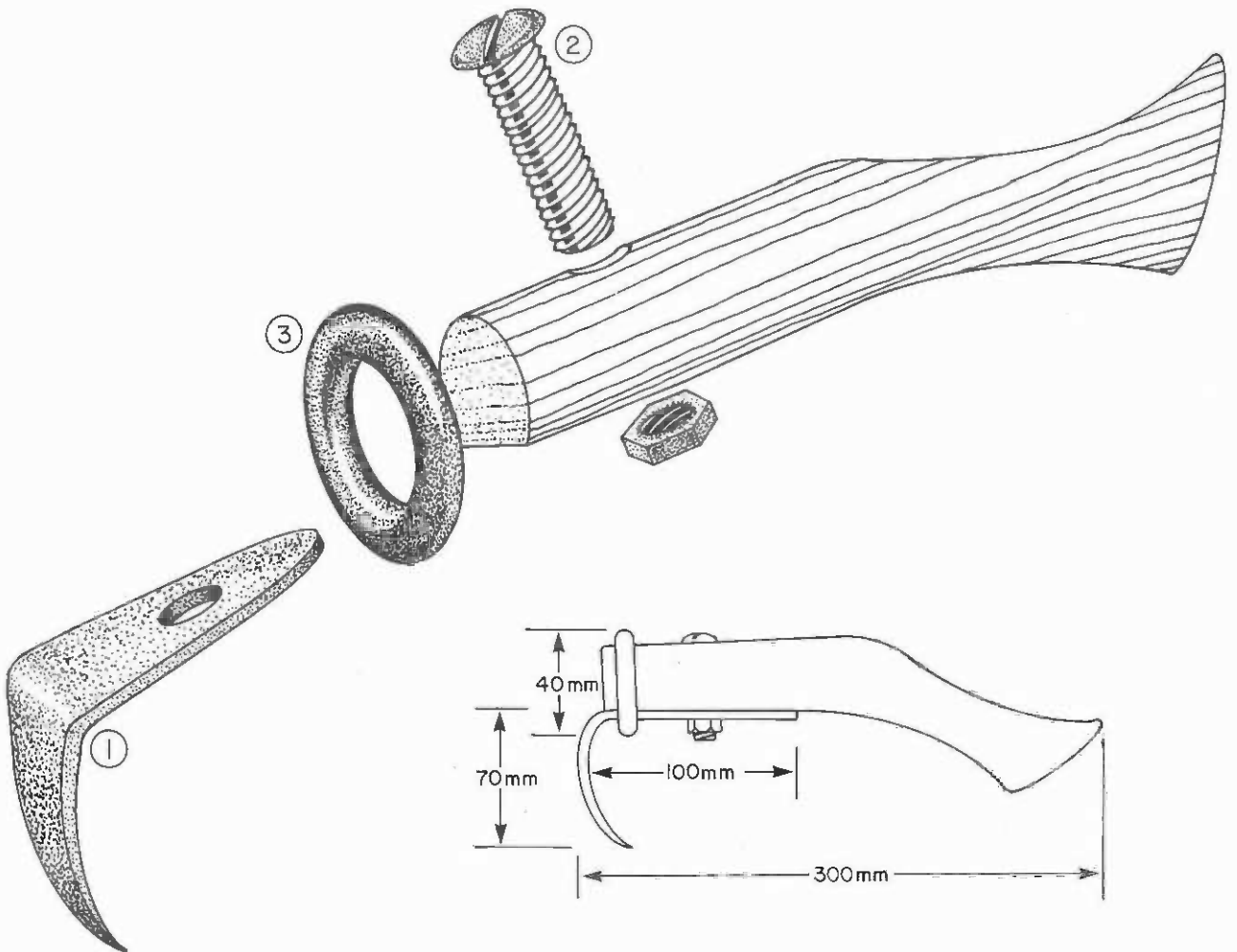

5. Pickaroon

Use

As a lever or hook to lift, turn, drag or load logs.

Material

A used axehead with a handle.

Instructions

Cut away the parts of the axehead as shown in the diagram. The finished tool looks much like the end of a pick. The point of the pick should be sharpened and hardened. Sheet 7 of this booklet shows how to use this tool.

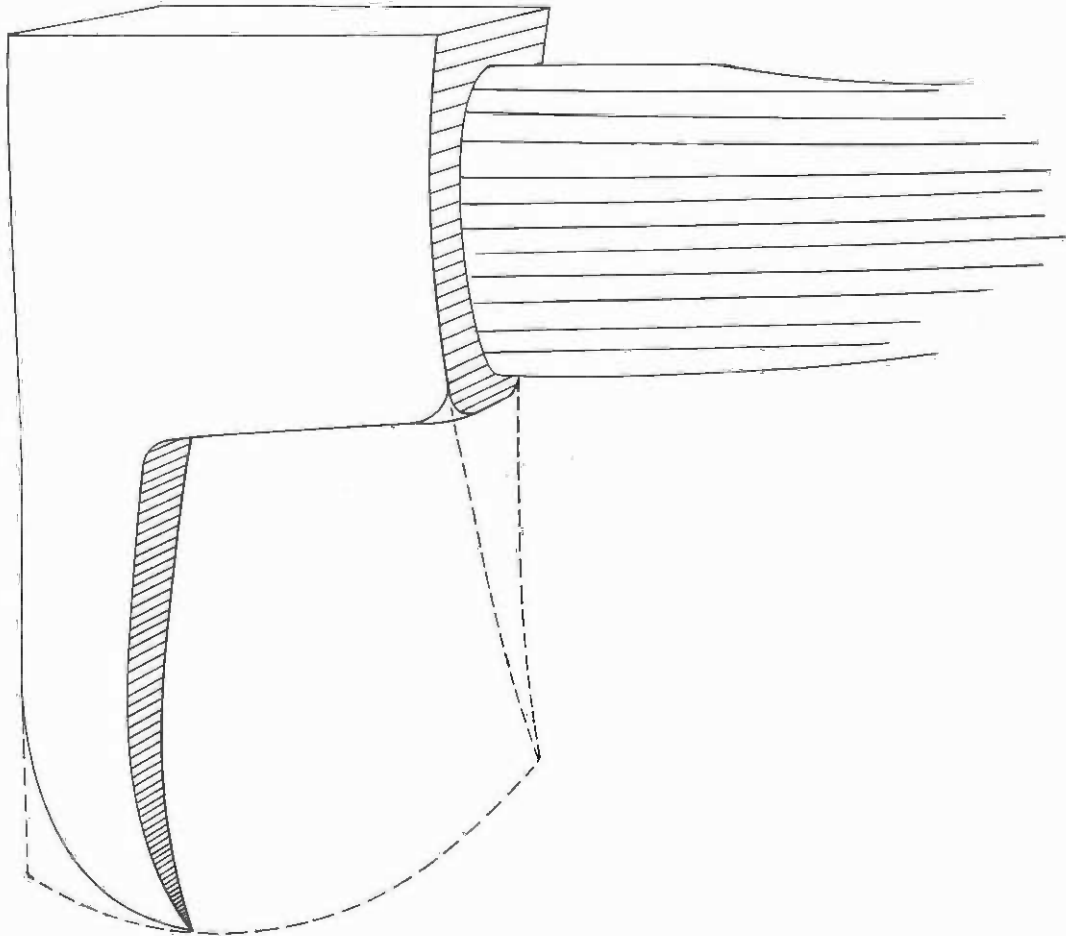

6. Sappie

Use

As a lever or hook to lift, turn, drag or load logs.

Material

1 piece of good quality steel 275-320 x 140 x 60 mm,
1 wooden handle 1 100-1 300 mm (somewhat longer
than an axe handle).

Instructions

Shape the steel to form the head of the pick as shown.
Sharpen and harden the point. Attach the handle as you
would an axe handle. Sheet 7 of this booklet shows how
to use this tool.

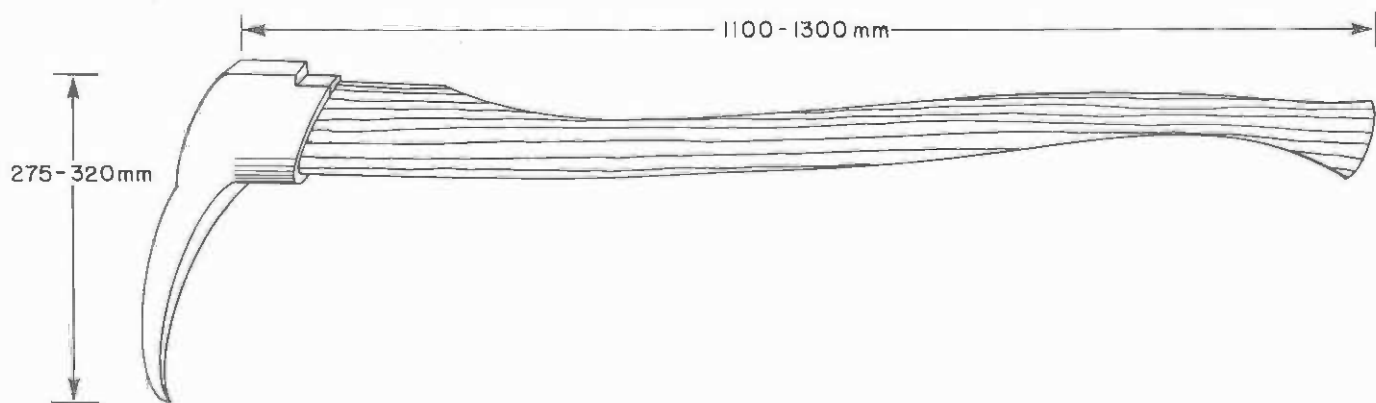

7. Using a pickaroon or a sappie

Instructions

A pickaroon or a sappie can be used point up as a lever to clear logs caught on obstacles or it can be driven point down into a log to pull it over rough ground. In harvesting on steep terrain these make ideal tools to keep logs moving. They can also be used for loading, unloading or moving logs short distances on level ground.

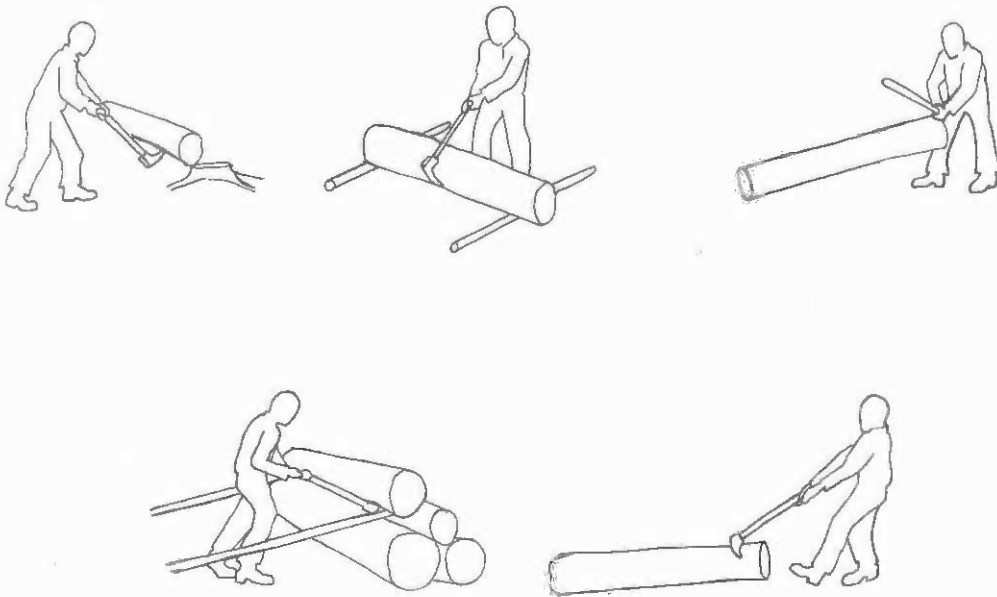

8. Cant hook 1

Use

To move or turn logs and take down lodged trees.

Material

1 iron bar 300-350 x 20 x 13 mm (1), 1 iron bar 125 x 50 x 10 mm (2), 1 piece of pipe 40 mm inner \varnothing x 70 mm (3), 1 piece of hardwood 55 mm \varnothing x 1350 mm (4), 1 screw, 2 bolts 12 mm \varnothing x 85 mm, 1 bolt 12 mm \varnothing x 40 mm with nuts and washers.

Instructions

Shape the hook using the longer iron bar (1). Sharpen and harden the point. Make the bracket to attach the hook to the handle using the shorter iron bar (2). Make the end-piece using the piece of pipe (3) and weld on a metal V-notch. Drill holes in the hook, bracket, end-piece and handle as shown. Assemble the cant hook. The V-notch must be in line with the hook and the hook must be free to move.

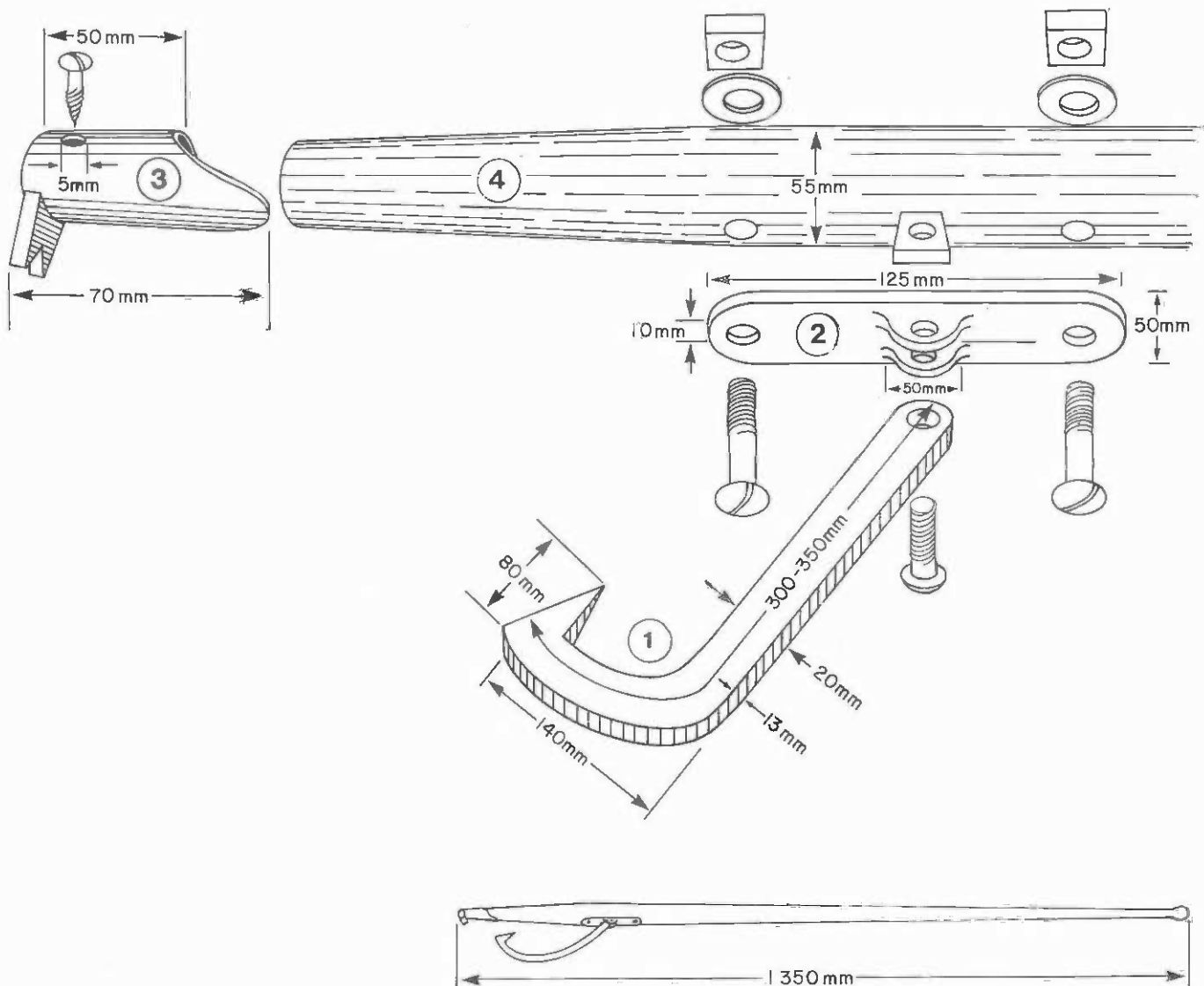

9. Cant hook 2

Use

To move or turn logs and take down lodged trees.

Material

1 iron bar 450 x 20 x 10 mm (1), 1 iron bar 300 x 40 x 10 mm (2), 1 bolt 10 mm Ø x 40 mm with nut, 1 pole 50 mm Ø of appropriate length.

Instructions

Shape the hook using the longer iron bar (1). The point should have an angle of 30° and be about 60 mm long. Sharpen and harden the point. Shape the ring to attach the hook to the handle using the shorter iron bar (2). Drill a hole in the hook and the ring as shown. Bolt the hook and the ring together. The hook must be free to move. Cut a pole for the handle and shape one end to fit the ring.

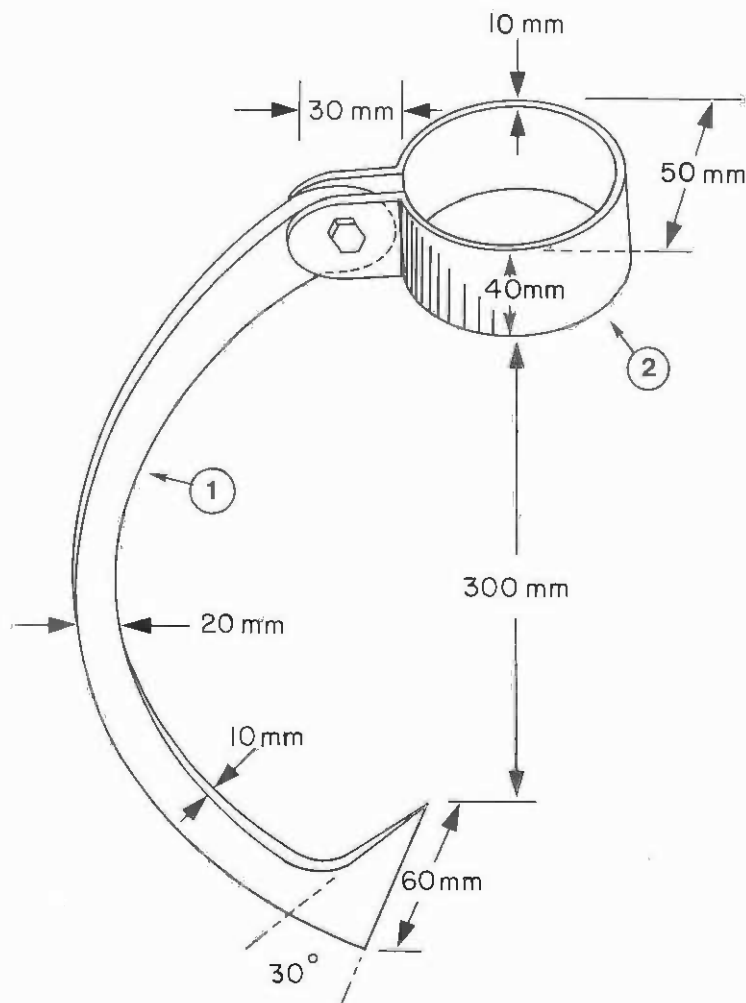

10. Cant hook 3

Use

To move or turn logs and take down lodged trees.

Material

1 iron bar 350 x 20 x 15 mm, 1 iron rod 15 mm \varnothing x 340 mm, 1 pole of appropriate size.

Instructions

Shape the hook and eye. Sharpen and harden the point. Shape the iron rod to form a ring using the dimensions shown. Fit the ring in the eye of the hook. This tool can be easily carried in the field and a pole handle can be cut when needed. The shape of the ring allows for use on both large logs (1) and small logs (2).

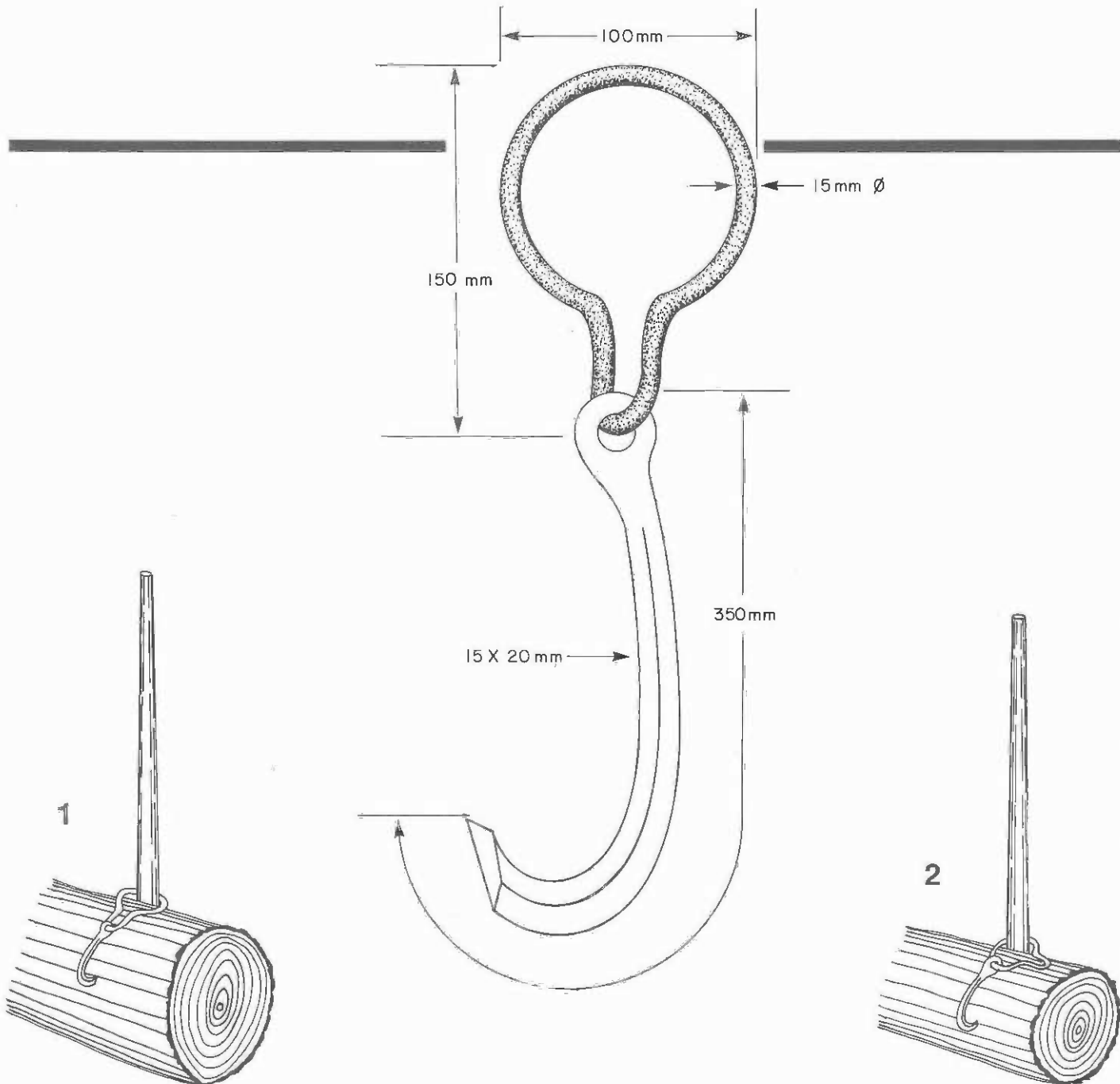

11. Pike and log hook

Use

To push, pull or guide floating logs.

Material

A sheet of flat iron 180 x 180 x 5 mm, a pole 3 000-4 000 mm, 4 screws.

Instructions

Cut the sheet of iron to form the hook using the dimensions below. Drill four holes as shown. Bend the bottom of the hook to fit the pole handle. Attach the hook to the handle with screws. The straight spike is for pushing logs. The angled spike is for pulling logs.

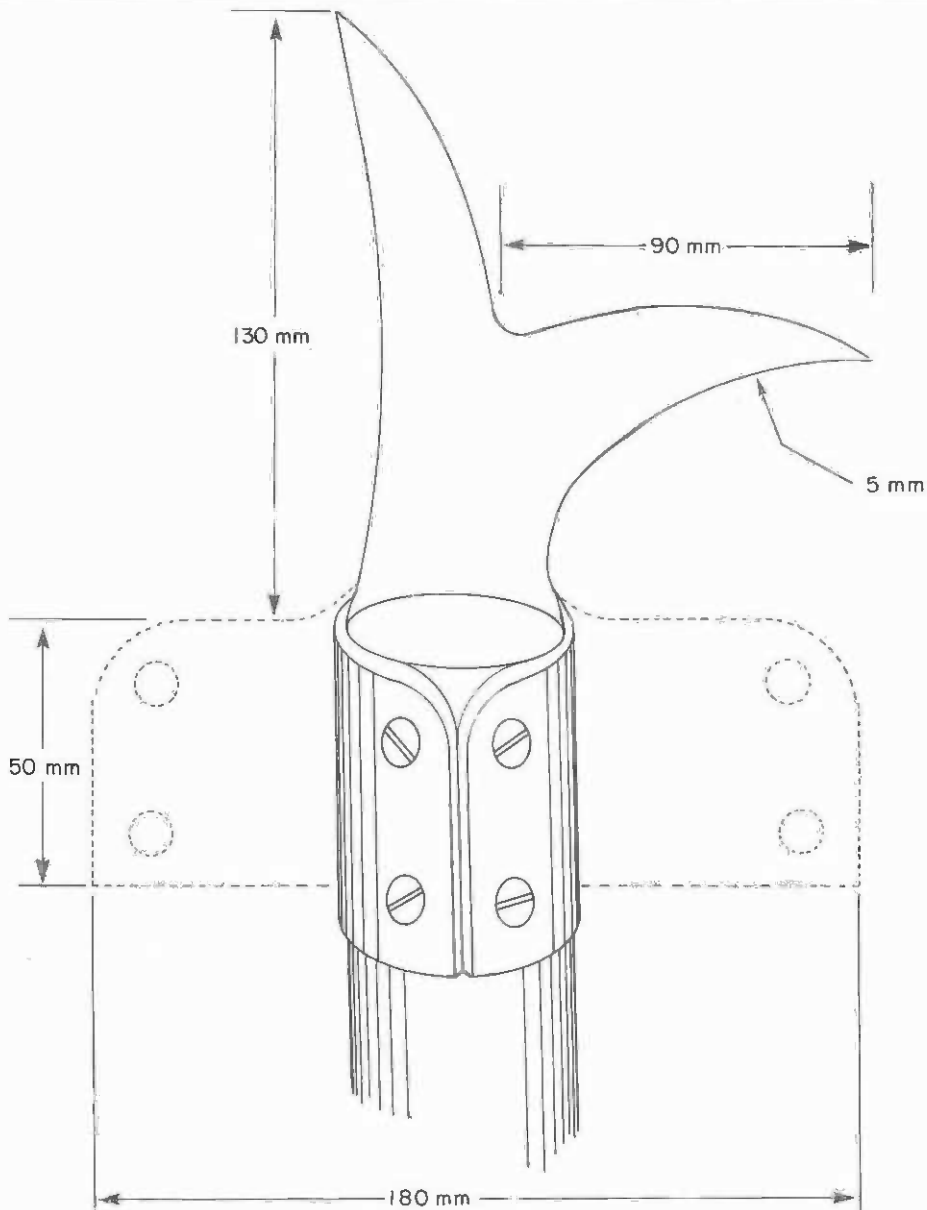

12. Firewood press

Use

To bundle firewood into compact loads.

Material

Logs and tree sections of various diameters and lengths, a length of chain or rope about 750 mm, a heavy pole, a wooden hook.

Instructions

Build the base of the press using two pieces of wood about 150 mm \varnothing and three cross-braces about 80 mm \varnothing . Attach the four uprights using wood about 50 mm \varnothing x 600 mm. Attach the chain, pole and wooden hook. Load the firewood to be bundled between the uprights (1). Stretch the chain over the firewood, slide one end of the pole under the firewood and attach the other end of the pole to the hook (2). The bundle of firewood can then be tied by one person.

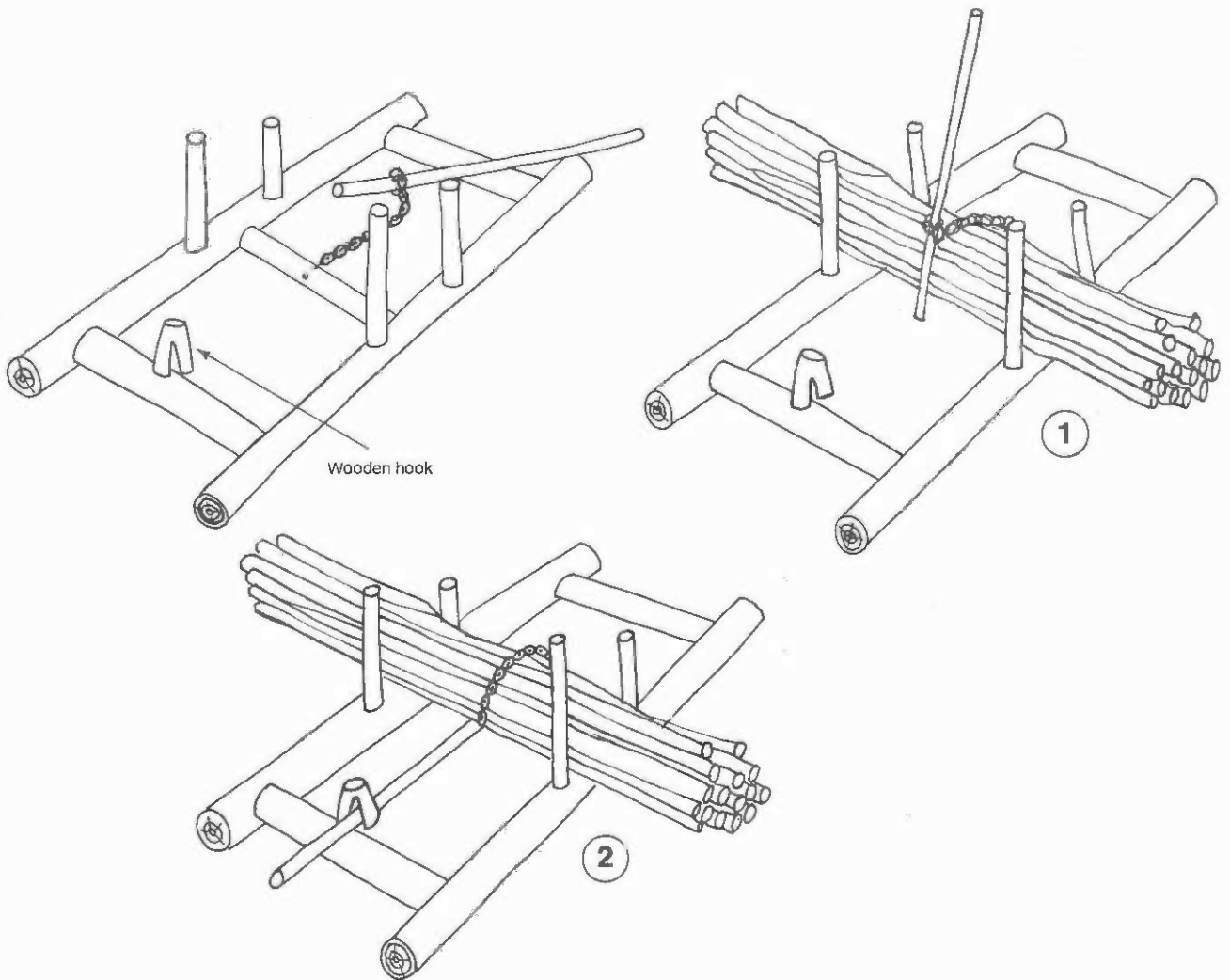

13. Stump spike 1

Use

To hold logs in place for barking or other work.

Material

A piece of mild steel 175 x 35 x 12 mm.

Instructions

Cut or forge the spike using the dimensions below. The offset edge of the spike is used to hammer it into the stump. Then a log is pushed on to the top point of the spike to hold it firmly in place for the work to be done.

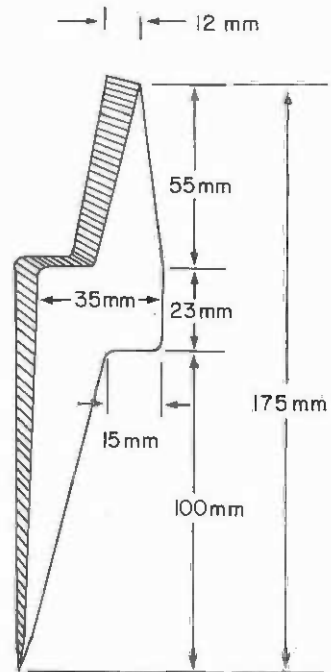
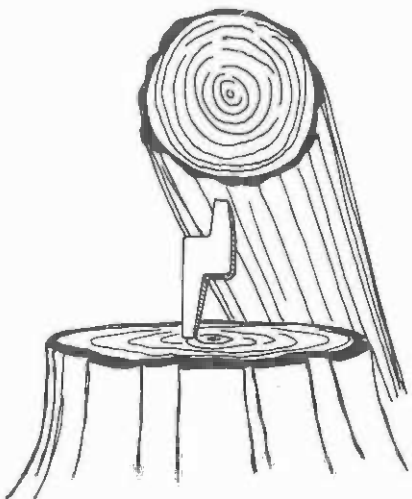

16. Barking tool 2

Use

To strip bark from logs.

Material

1 piece of wood 55 mm \varnothing x 1 000 mm, 1 piece of high carbon steel (or a piece cut from an old crosscut sawblade) 200 x 100 x 3 mm, 1 piece of soft iron 100 x 90 x 3 mm, 1 bolt 5 mm \varnothing x 40 mm with nut.

Instructions

Shape the handle using the pattern and the dimensions below. The rounded knob at the top of the handle and the lower tapered part serve as handgrips. Shape the soft iron around the lower part of the handle to form a socket. Cut the piece of steel to form a blade with a spike on one side. The spike is used to turn the logs while barking. Grind or file the cutting edge of the blade so that it can be pushed along the surface of the log under the bark without digging into the wood. Weld the blade to the handle socket and bolt both to the handle.

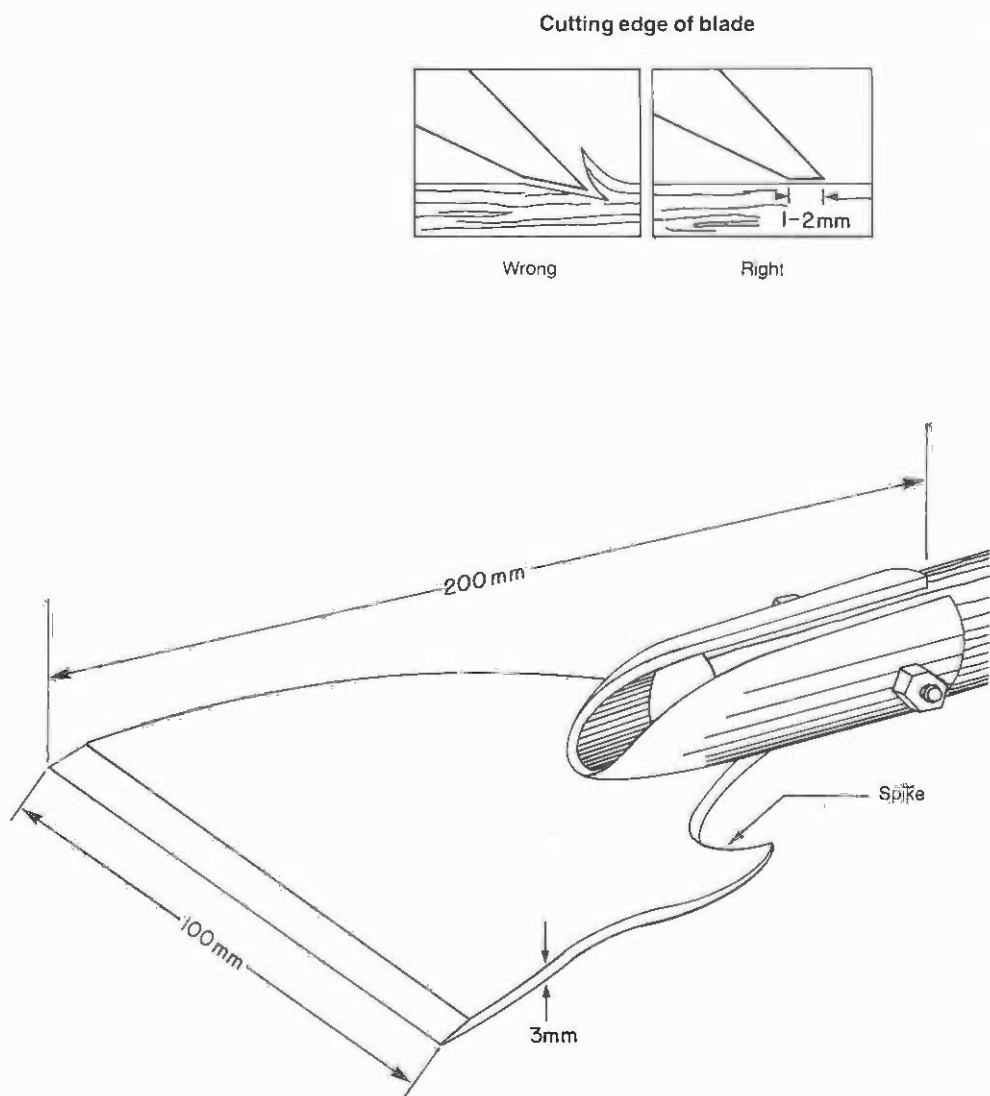
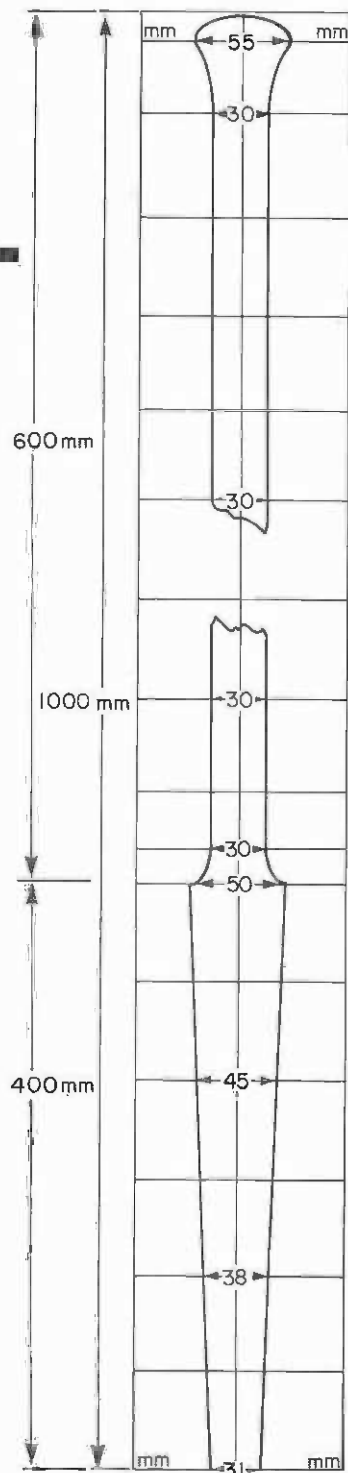

17. Barking tool 3

Use
To strip bark from logs.

Material
A piece of steel from a used truck spring 130 x 90 x 7 mm,
1 mild steel rod 15 mm \varnothing x 1 220 mm, 2 pieces of rubber
hose or tube 15 mm inner \varnothing .

Instructions
Cut the blade for this tool from the truck spring using the
dimensions below. Grind or file the cutting edge of the
blade. Weld the blade to the steel rod. Slide the two
pieces of rubber hose or tube on to the steel rod to serve
as handgrips.

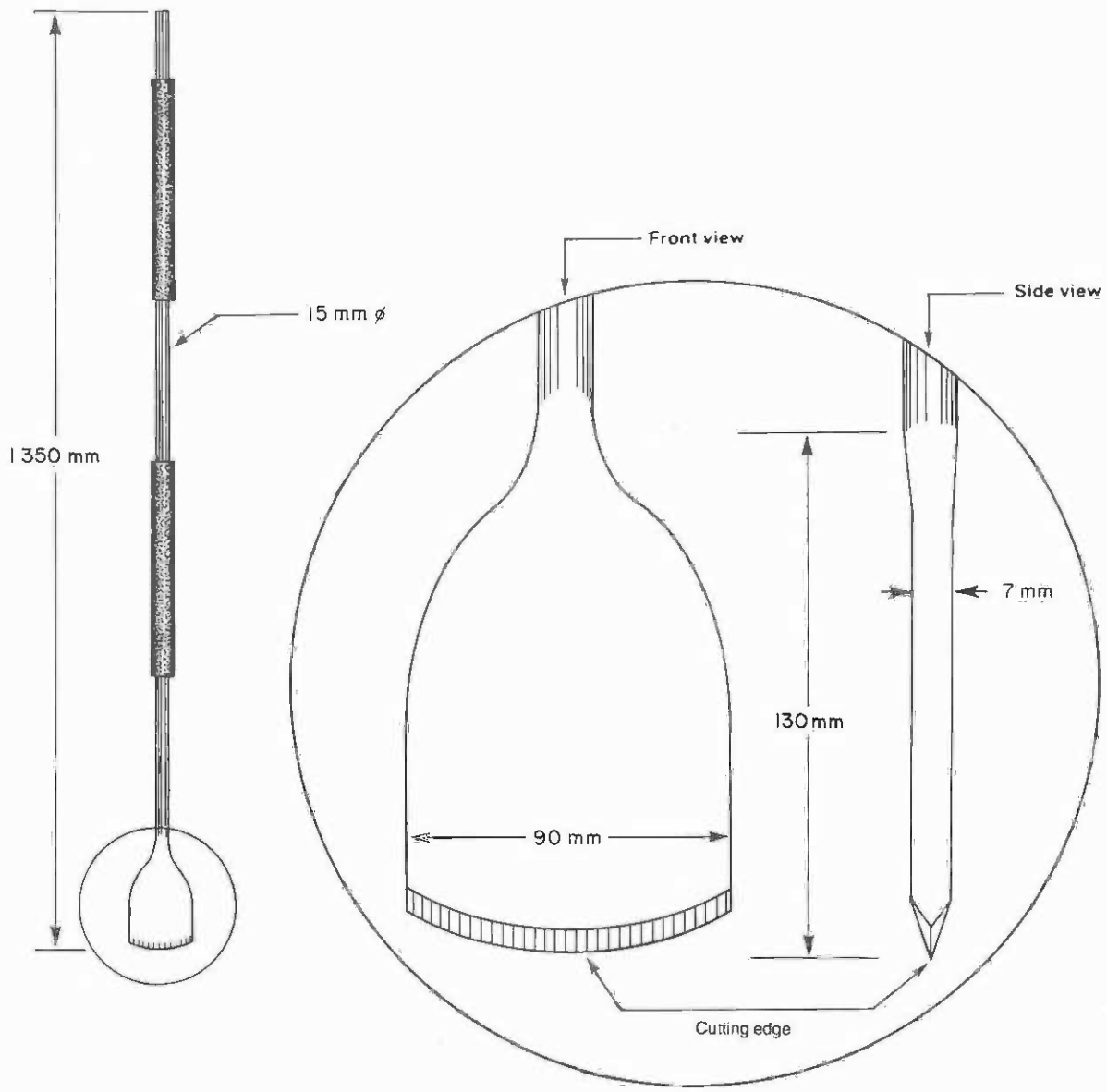

18. Pit or trestle sawing

Use

To square logs or cut them into planks.

Material

Heavy logs or timbers.

Instructions

The three sawing methods shown below can be used at logging sites to reduce logs to timbers or planks in order to transport them more easily. A temporary location can be made by digging a pit of suitable length and width between 750 to 1 500 mm deep (1). Build a log frame next to the pit and a log ramp over the pit. The log to be sawn is rolled up the ramp and held in position over the pit by wedges, notches in the ramp or wooden pegs. A transportable trestle and crutch can be built to hold logs for sawing (2). Permanent supports to hold logs for sawing can be built on posts sunk into the ground (3).

Note

See Sheet 19 of this booklet for the kind of saw to use for pit or trestle sawing.

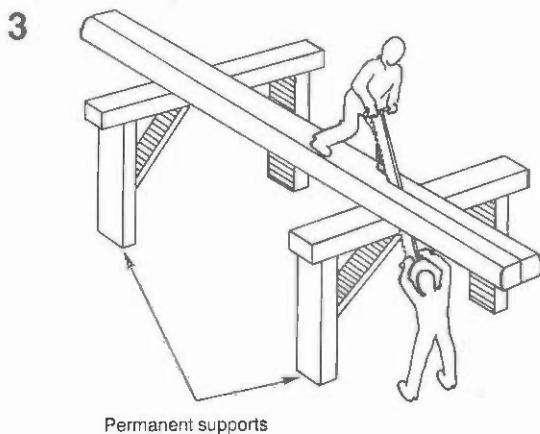
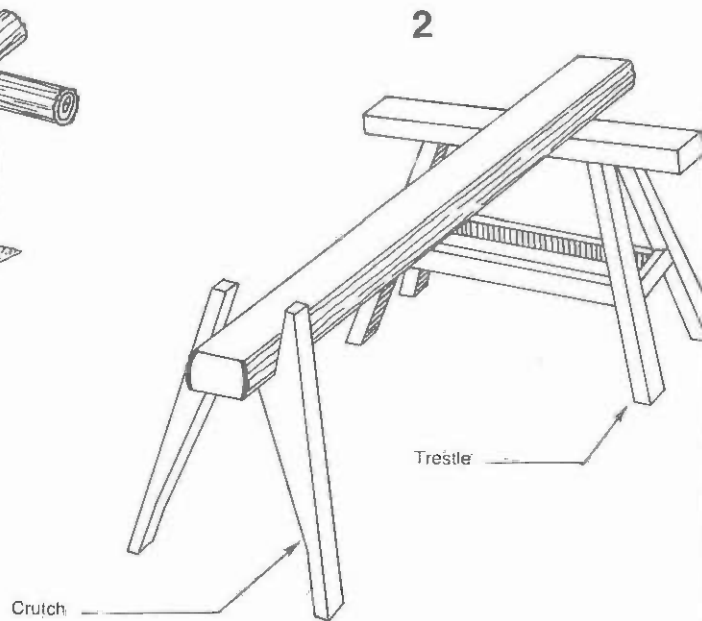
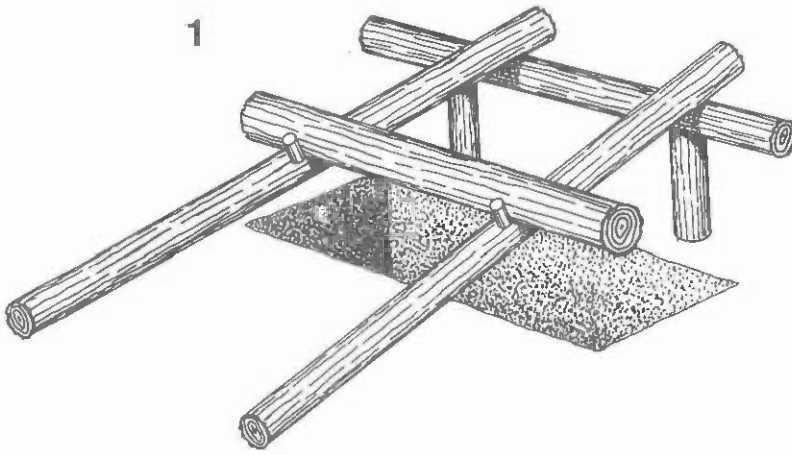

19. Pit or trestle saw

Use

To square logs or cut them into planks.

Note

When cutting planks, mark the first cut with a chalkline. Lay a cord coated with chalk along the log and hold it tightly at each end. Then, lift the cord at the centre and snap it to mark the cutting line.

Instructions

A pit or trestle saw has no raker teeth. It has only coarse peg teeth that are sloped toward the bottom end of the blade as shown. This kind of saw varies in length from 1 100 mm to as long as 4 000 mm. The sawblade should be wide enough to maintain a straight cut. Logs are sawn by two people; one works above on the log being cut and one works below, in the pit or on the ground. The person above pulls the saw up and the person below pulls the saw down. Cutting is done by the angled peg teeth as the weight of the saw and the person below pull the saw down. The handle at the lower end must be easily removable so that the sawblade can be withdrawn from the cut when required. As the saw cut becomes longer, the cut is kept open with wooden wedges to keep the saw from binding.

Sawteeth angles

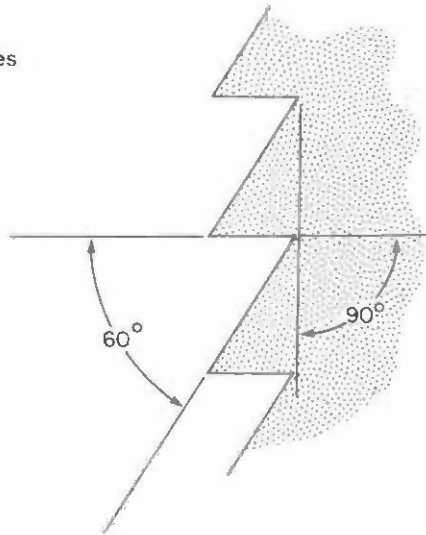
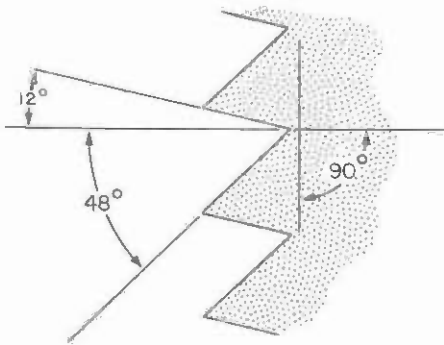

Upper handle

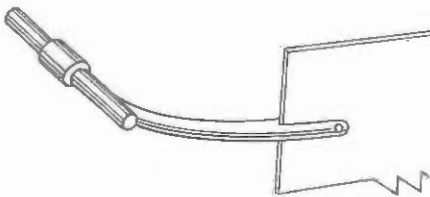

End handles

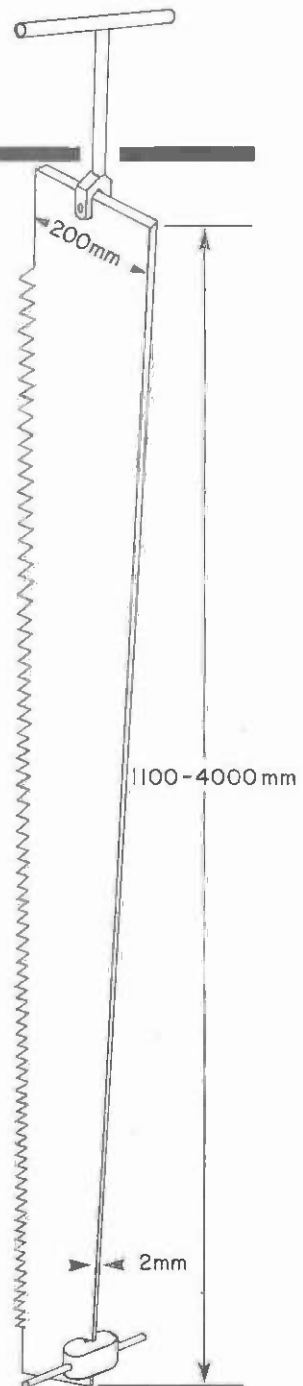
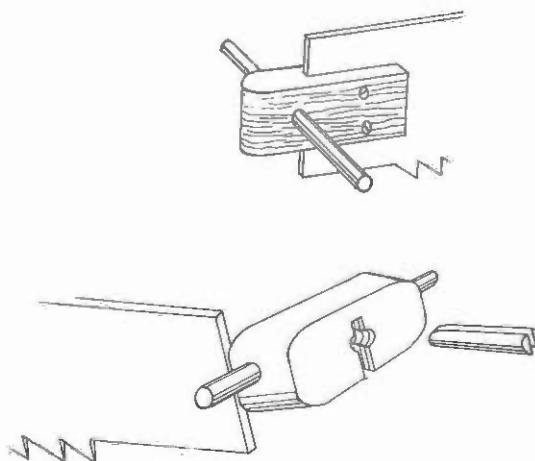

20. Splitting maul

Use

To split short lengths of firewood.

Material

A heavy triangular piece of steel 100 x 100 mm at the base and 200 mm long, a threaded pipe socket for 25 mm \varnothing pipe, a piece of pipe of 25 mm \varnothing x 750 mm, a length of rubber hose or tube 25 mm inner \varnothing x 300 mm.

Instructions

Weld the pipe socket to the steel triangle as shown. Thread one end of the piece of pipe and screw it into the pipe socket. Slip the rubber hose or tube on to the pipe to serve as a handgrip. This tool can be used as an axe, a mallet or a wedge.

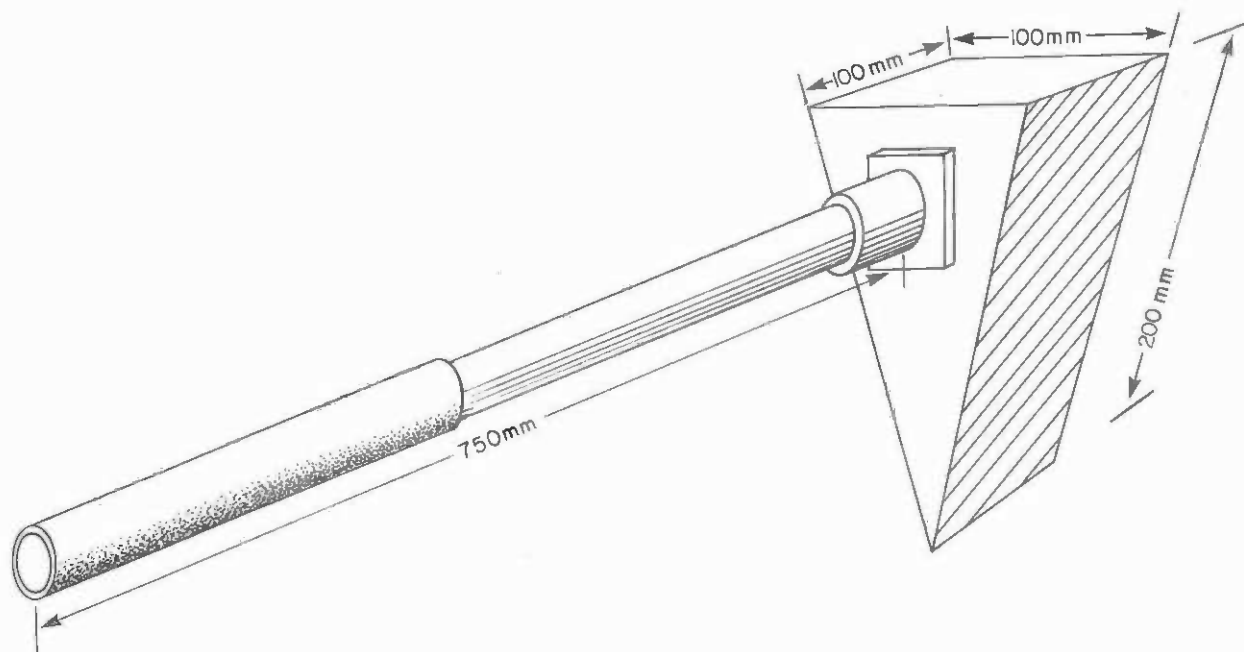

21. Splitting wedge

Use
To split wood or logs.

Material
A section of old truck spring about 200 x 60 x 10 mm,
(a piece of tempered steel can also be used).

Instructions
Heat the piece of steel to draw temper, twist it to the
desired angle (about 60°) and retemper. Grind or file the
cutting edge of the wedge. When this tool is driven into
wood parallel to the grain, the twist in the wedge will force
the wood apart.

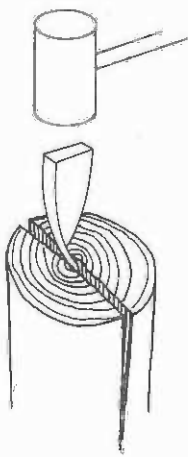
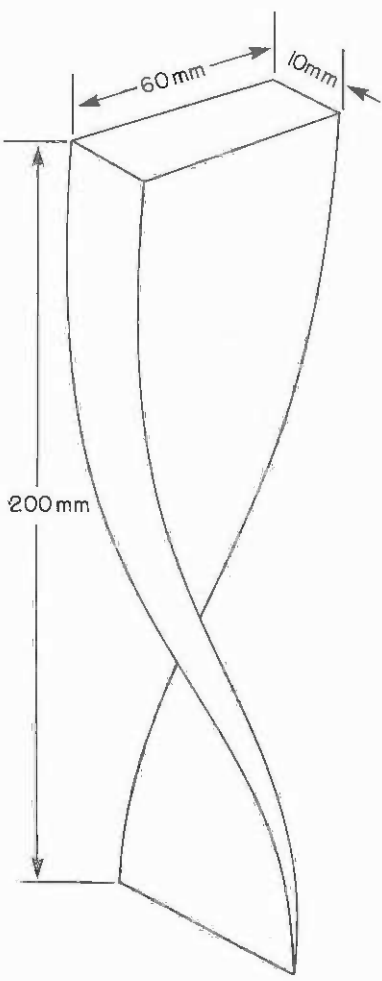

22. Splitting blade and mallet

Use

To split thin strips of wood from logs.

Material

A piece of old truck spring 525 x 65 mm, a piece of hardwood 40 mm Ø x 450 mm, a piece of dense hardwood 100 mm Ø x 660 mm.

Instructions

The blade is sometimes called a froe. To make the blade, the truck spring (1) is cut to the desired length (2). Heat and straighten the blade and shape one end to form an eye (3). Temper the blade and sharpen one long edge by grinding or filing. Attach the short piece of hardwood for the handle. Shape the long piece of hardwood to form the mallet. Drive the splitting blade (froe) into the top edge of a short log using the mallet. Twist the blade by pushing or pulling the handle to split off a strip of wood. This tool is good for making clapboards or shakes for roofing.

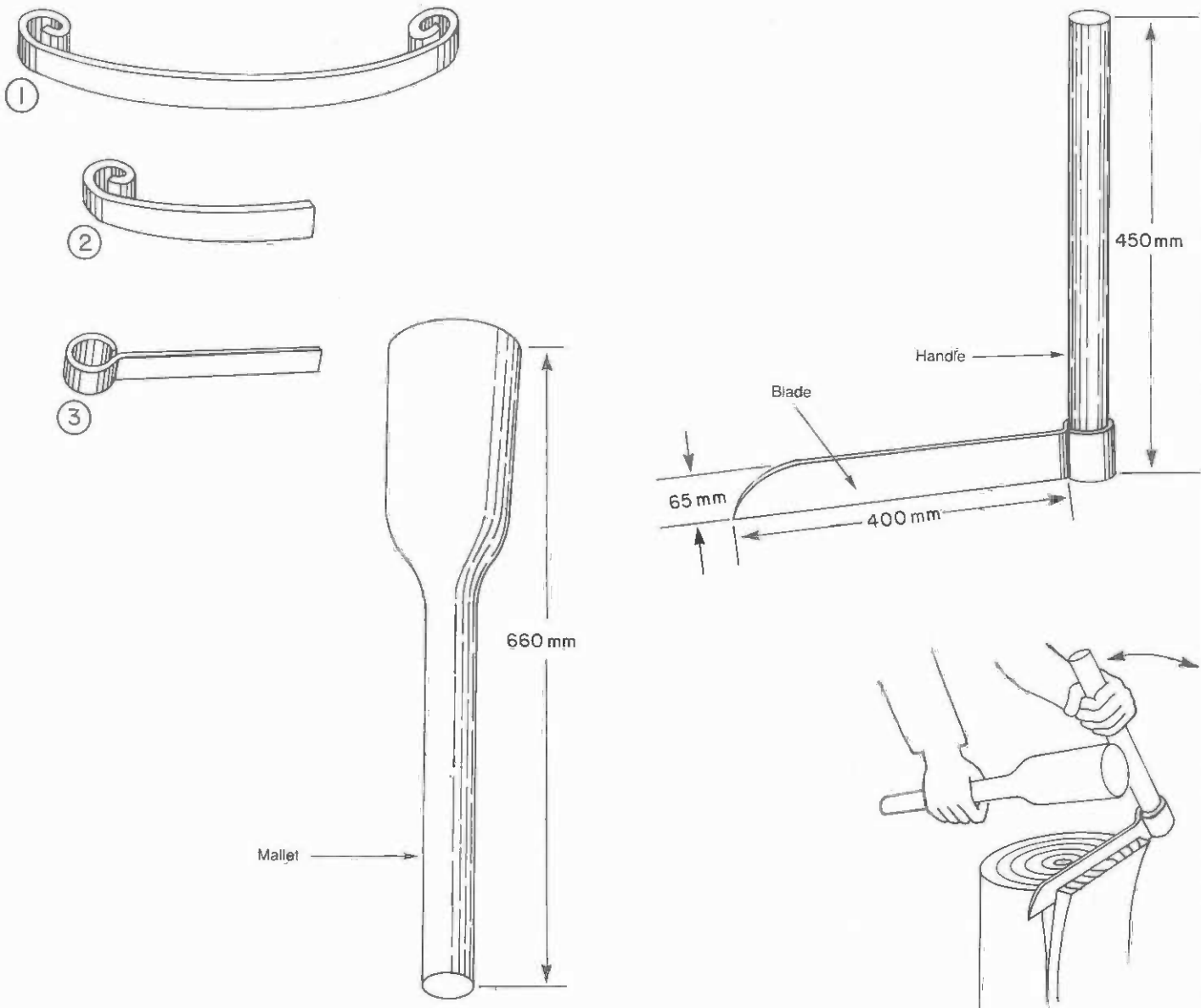

23. Wooden hammer 1

Use

To drive posts.

Material

A piece of dense hardwood 90 mm \varnothing x 200 mm (1), a piece of pipe 90 mm inner \varnothing x 150 mm (2), a piece of hardwood which tapers from 50 mm \varnothing to 30 mm \varnothing of appropriate length (3).

Instructions

Fit the 200-mm piece of hardwood (1) into the pipe (2) to form the head of the hammer. Cut or drill a slot through the head of the hammer and drive in the tapered wooden handle (3). The handle, which is larger at the top, will be wedged in the slot. The piece of pipe gives weight to the hammer and prevents the hardwood head from splitting.

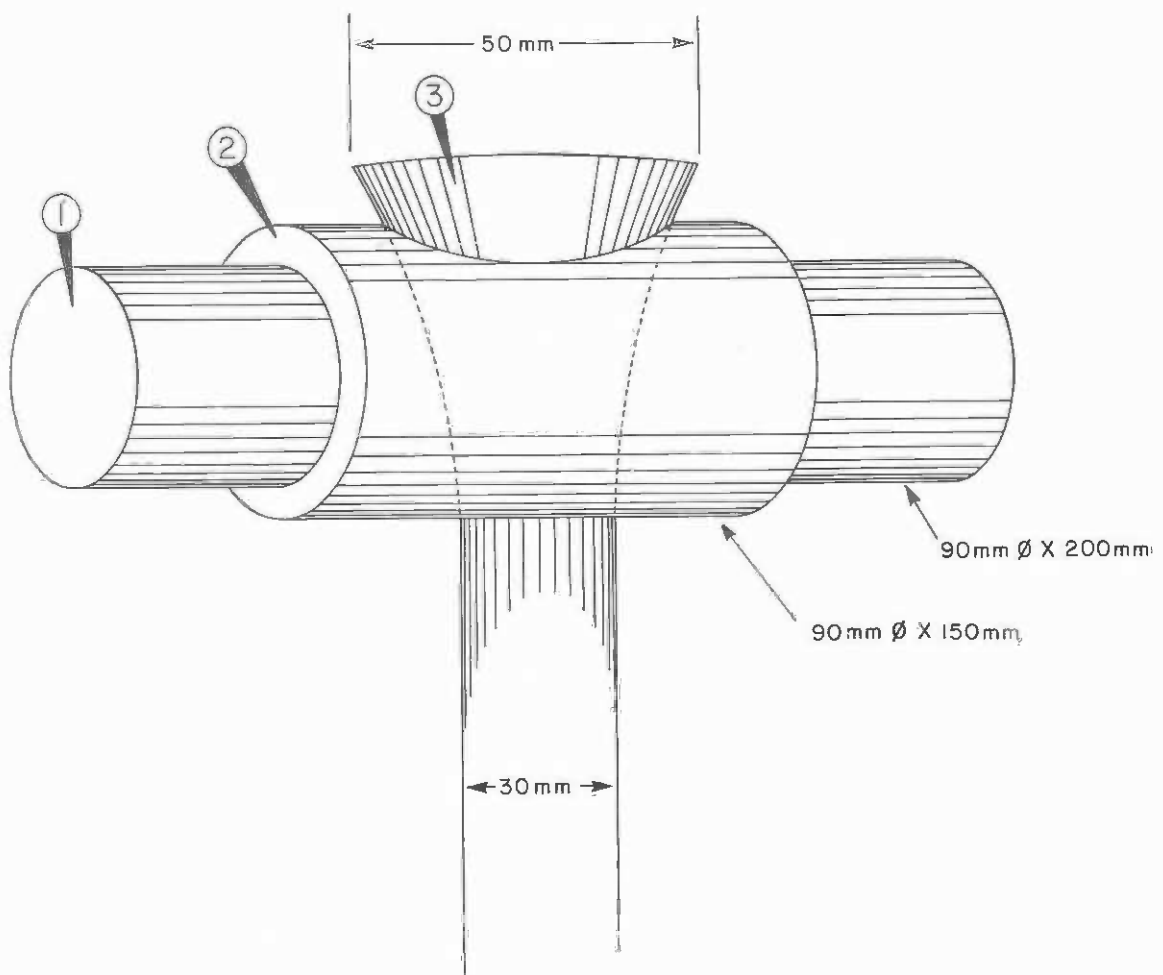

24. Wooden hammer 2

Use

To drive posts.

Material

A piece of dense hardwood 170 mm \varnothing x 230 mm (1), 2 iron rings 150 mm inner \varnothing x 25 x 5 mm (2), 8 nails, a hardwood handle 30 mm \varnothing x 900 mm (3), a small hardwood wedge.

Instructions

Shape both ends of the head of the hammer (1) to receive the iron rings and nail the rings (2) in place. Drill a hole 30 mm \varnothing through the head of the hammer for the handle (3). Slit the end of the handle to be inserted into the head. Drive the handle through the head and fasten it in place by driving the small wooden wedge into the slit.

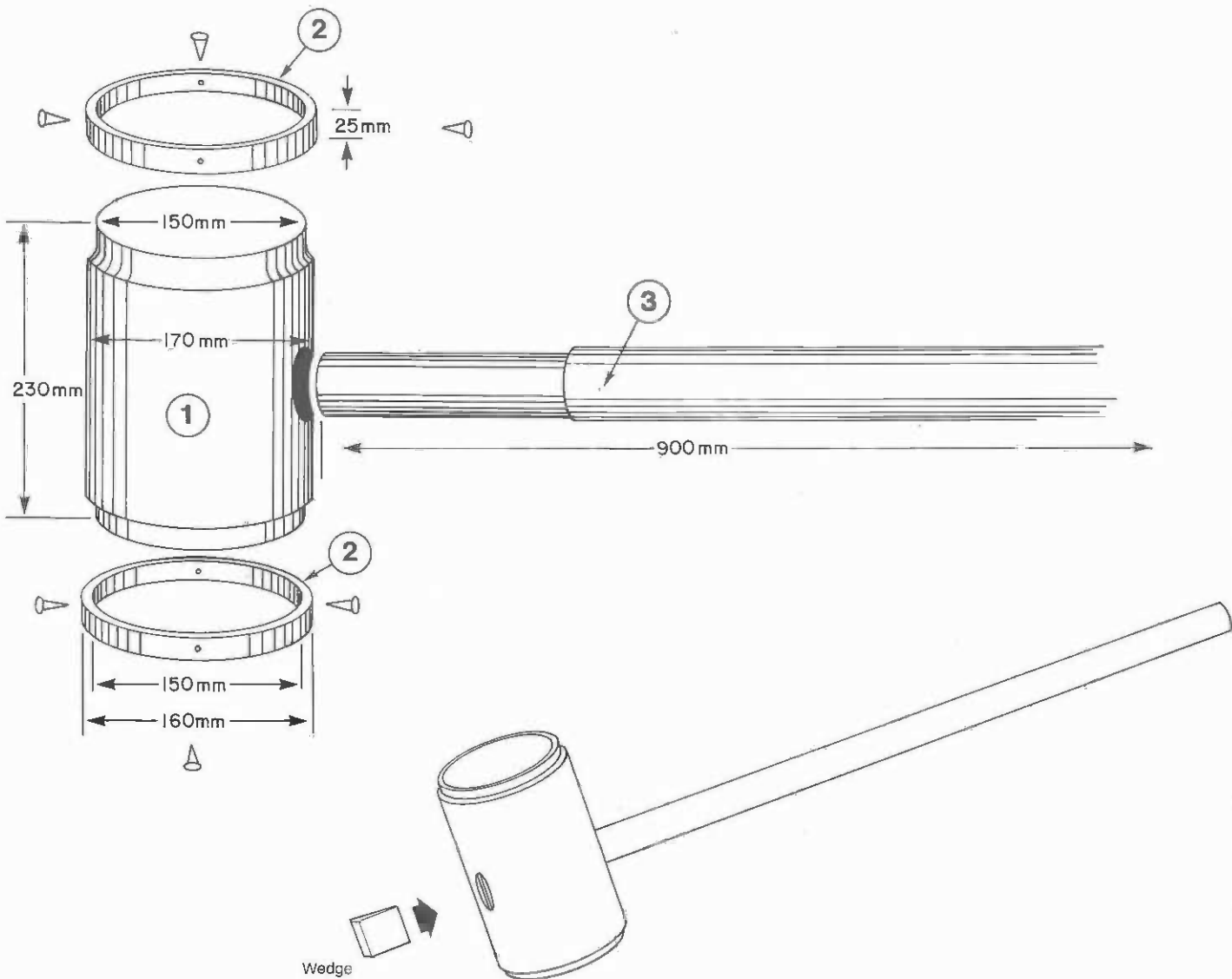

DESIGN MANUAL ON BASIC WOOD HARVESTING TECHNOLOGY

BOOKLET 6

EQUIPMENT FOR GENERAL USE

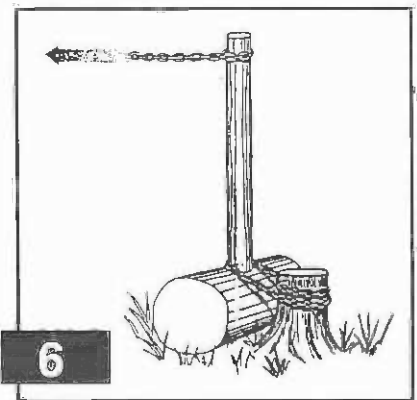
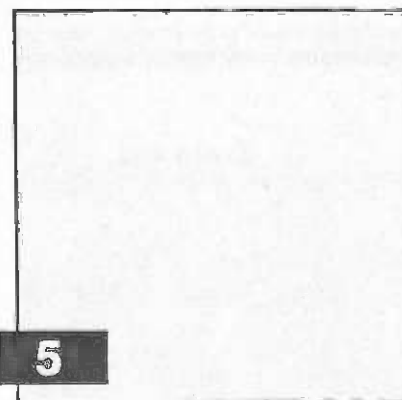
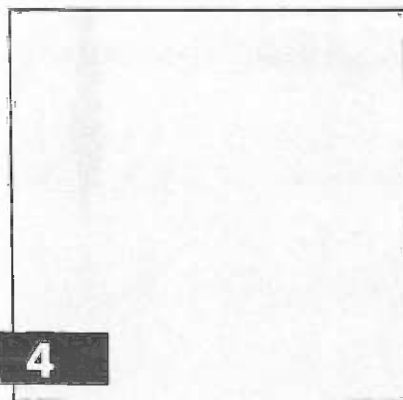
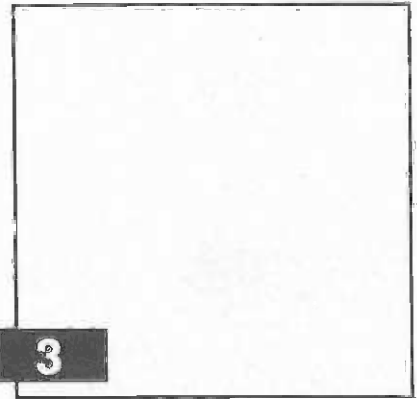
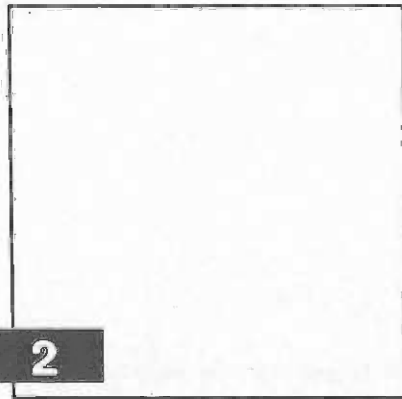
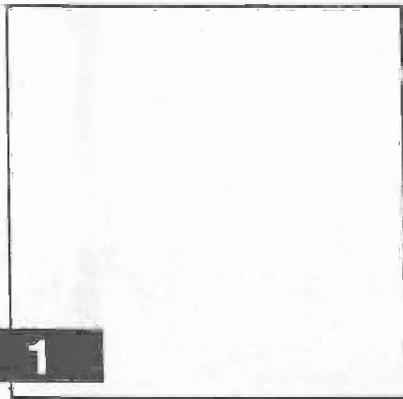

The designations employed and the presentation of material in this publication do not imply the expression of any opinion whatsoever on the part of the Food and Agriculture Organization of the United Nations concerning the legal status of any country, territory, city or area or of its authorities, or concerning the delimitation of its frontiers or boundaries.

M-39
ISBN 92-5-102537-1

All rights reserved. No part of this publication may be reproduced, stored in a retrieval system, or transmitted in any form or by any means, electronic, mechanical, photocopying or otherwise, without the prior permission of the copyright owner. Applications for such permission, with a statement of the purpose and extent of the reproduction, should be addressed to the Director, Publications Division, Food and Agriculture Organization of the United Nations, Via delle Terme di Caracalla, 00100 Rome, Italy.

© FAO 1989

Contents

1. Sliding hooks
 2. Terminal pin
 3. Quick release link
 4. Plate chain link
 5. Anvil 1
 6. Anvil 2
 7. Wire twister
 8. Stake driver
 9. Post driver
 10. Water level
 11. Earth scraper
 12. Axe hoe
 13. Stump puller
 14. All-purpose hook
 15. Ground anchor
 16. Use of pulley blocks
 17. Brush hook
 18. Machete
 19. Girdling tool
-

Symbols and abbreviations used

°	Degree (angle)	
∅	Diameter measurement	
kg	Kilogram	= 2.205 pounds (lb)
m	Metre	= 1.094 yards (yd)
mm	Millimetre	= 0.0394 inch (in)
%	Percentage	

Note

Additional valuable information on the kinds of tools shown in this booklet can be found in FAO Forestry Paper 36, *Basic Technology in Forest Operations* (ISBN.92-5-101260-1).

1. Sliding hooks

Use

To attach a choker, chain or cable to a skidding cable.

Material

Small pieces of round and flat scrap iron, chain, a small pulley.

Instructions

The diagrams below show three simple sliding hooks that can be made using scrap iron. The sling hook is made from iron rod 10 mm Ø by about 200 mm (1). The choker sling is made from a piece of flat iron about 200 mm by 80 mm (2). The notch and the pin in the hook keep it from coming off the cable. The keyhole in the plate holds the choker. The pulley hook balances on top of the skidding cable (3).

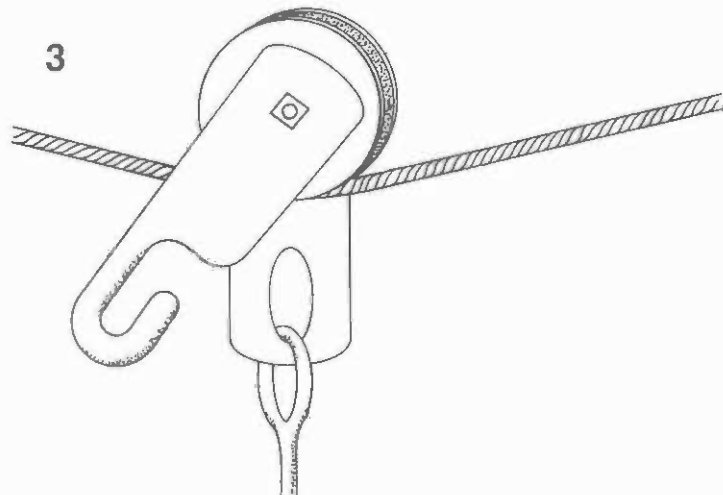
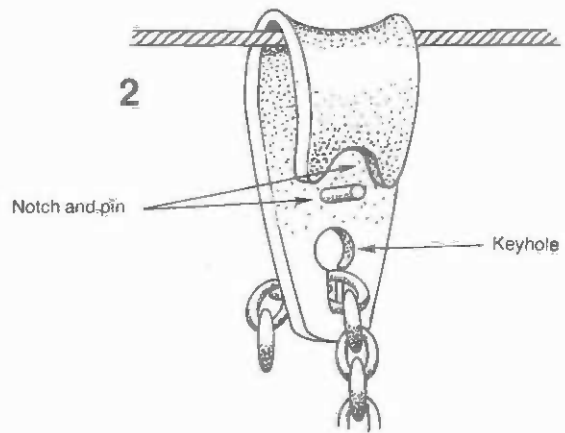
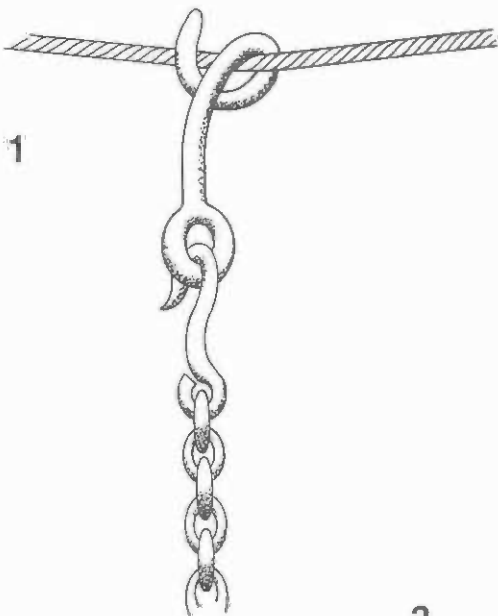

2. Terminal pin

Use

To hold several chokers during winching operations.

Material

1 iron bar 20 mm \varnothing x 200 mm, 1 iron rod 10 mm \varnothing x 300 mm.

Instructions

Shape the iron bar to form the terminal pin as shown. One end of the bar is tapered to a point and the other end is flattened to about 25 mm in width. A handle can be formed on the top end of the pin for convenience but this is not essential. Drill a hole 11 mm \varnothing through the pin about 25 mm from the top as shown. Shape a ring about 100 mm \varnothing using the iron rod and fit it into the hole. To attach a terminal pin, a loop of cable is threaded through the ring far enough to slip the point of the pin through the loop. The ring then secures the cable. When several chokers are attached to a skidding line, a terminal pin at the end will hold them during winching operations.

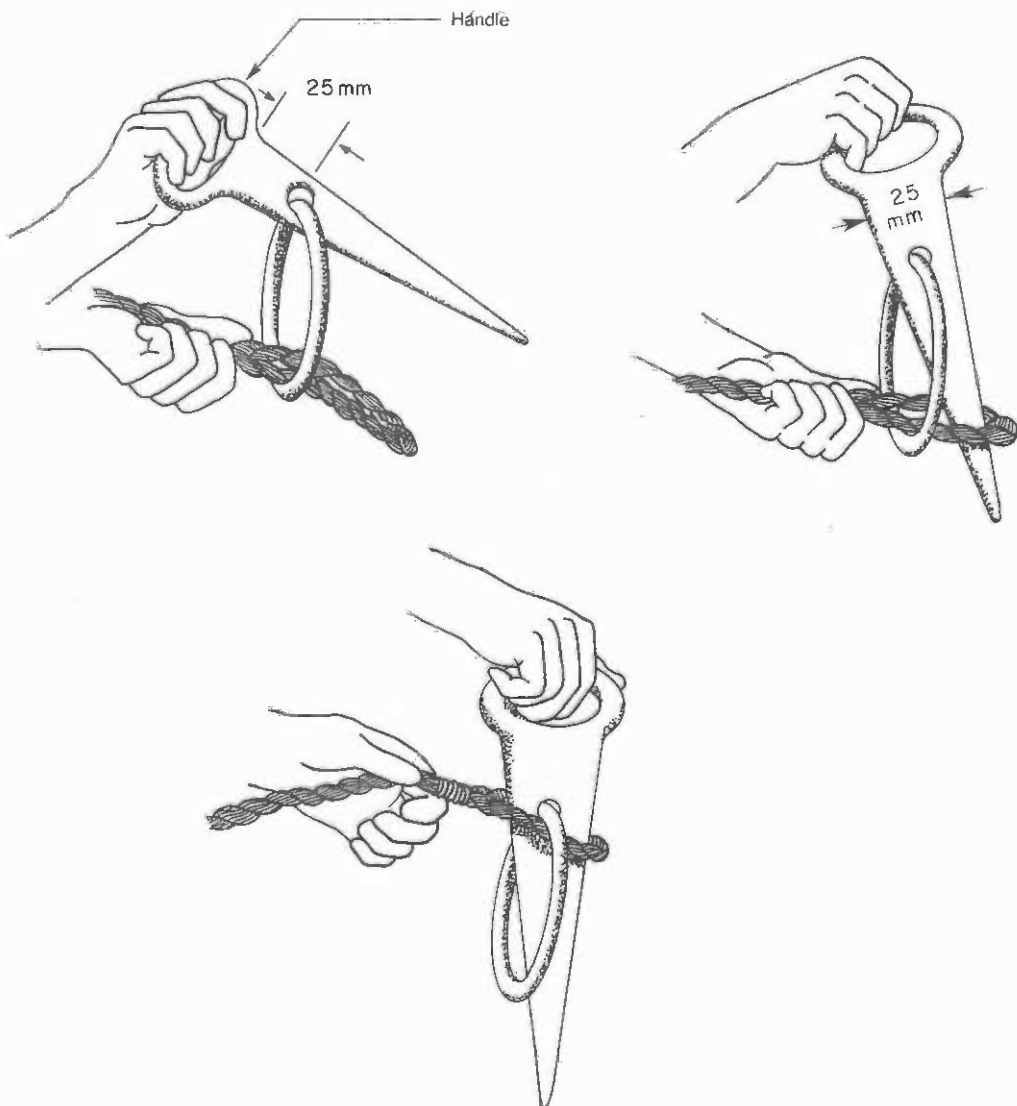

3. Quick release link

Use

To quickly release loads.

Material

1 iron bar 300 x 20 x 20 mm, 2 iron bars 150 x 20 x 20 mm,
1 iron rod 20 mm \varnothing x 500 mm, a rivet, a cotter pin.

Instructions

Shape the two curved pieces of the release link using the long iron bar and one of the short iron bars. The longer curved piece has a hole at one end for the rivet and an eye at the other end. The shorter curved piece has a hole at one end for the rivet and a small hole at the other end for the cotter pin. Rivet both curved pieces together so that they can open and close easily. Using the remaining short iron bar, shape a slide around both curved pieces to hold the link closed. The cotter pin keeps the slide in place in the closed position. Shape the iron rod to form a ring 150 mm \varnothing in the eye of the longer curved piece. This link can be easily opened under tension by removing the cotter pin and moving the slide forward.

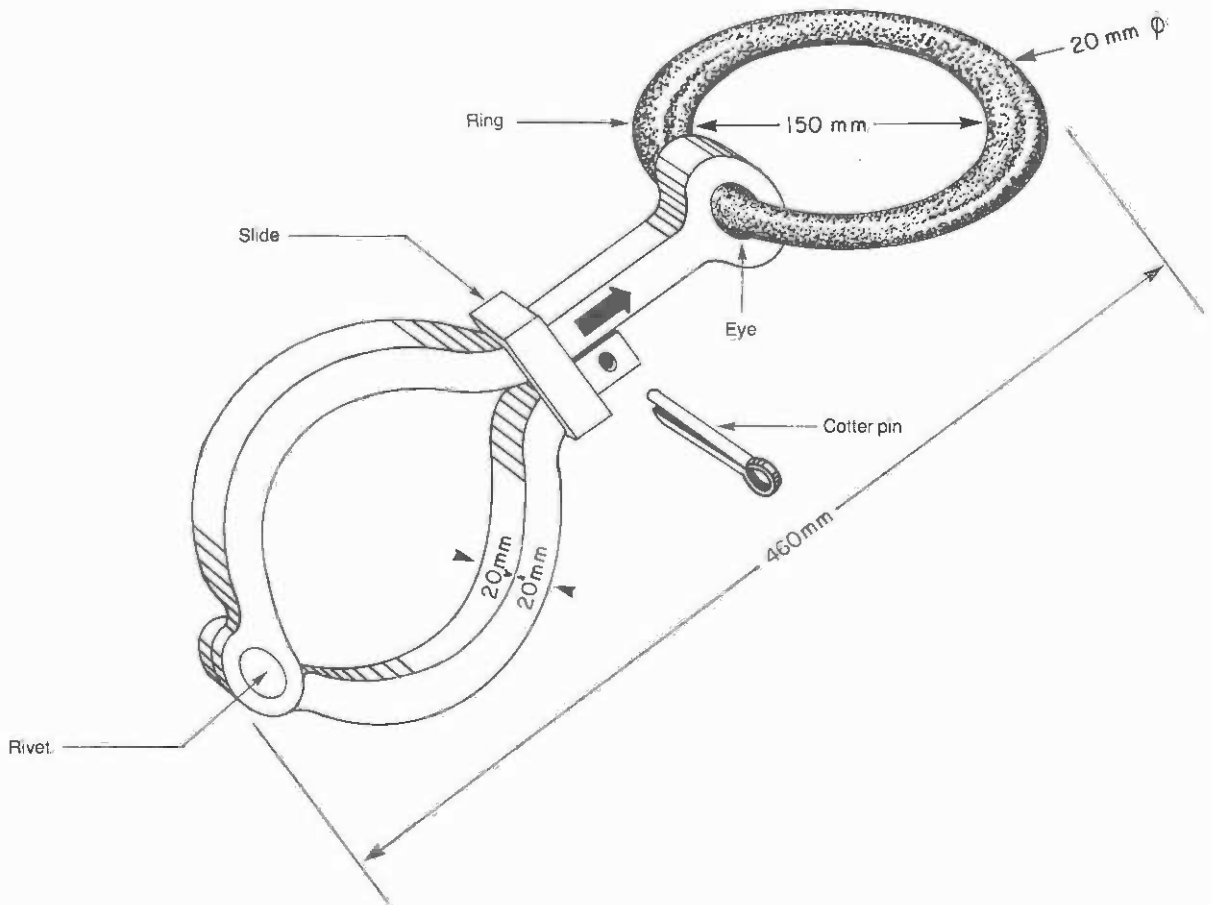

4. Plate chain link

Use

To repair a broken chain or to join two chains together.

Material

2 rectangular metal plates and 2 bolts with nuts (the size of the plates and the bolts will depend on the chain size).

Instructions

Drill two holes through each plate and tightly bolt the two chain links to be joined as shown.

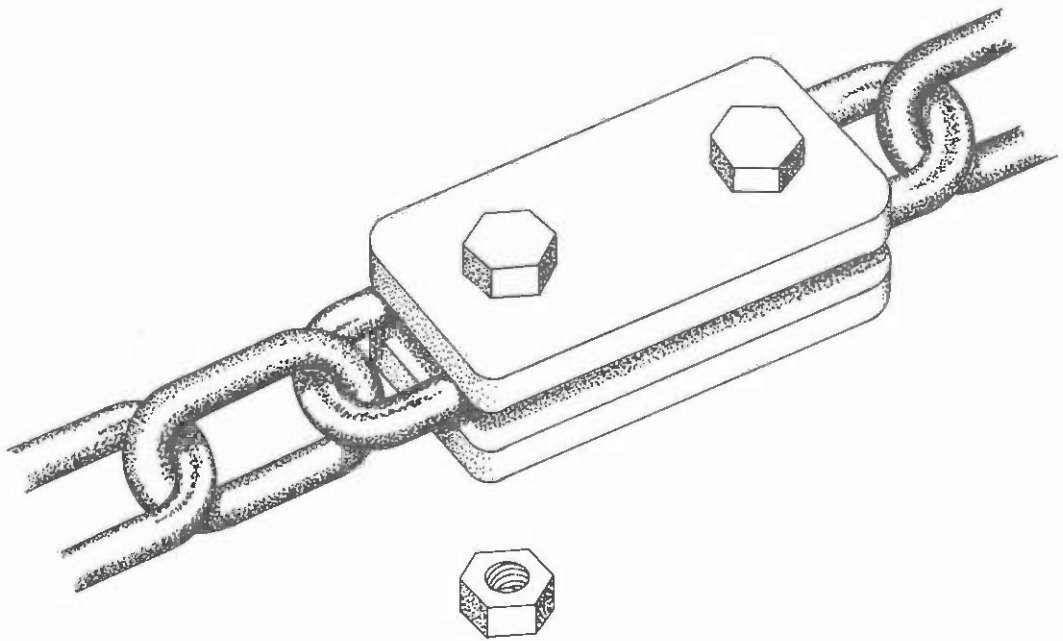

5. Anvil 1

Use

As a surface for metal working.

Material

A section of used railroad rail about 600 mm long, a wooden block or a piece of tree trunk about 600 mm \varnothing of appropriate height, 8 heavy lag screws.

Instructions

Shape the anvil with a cutting torch using the dimensions shown below. Grind one end of the anvil to form the horn. Cut slots in the base of the anvil and screw it tightly to the wooden block or tree trunk. Holes may also be cut in the back of the anvil to hold tools. The anvil should be positioned so that the working surface is at fingertip height.

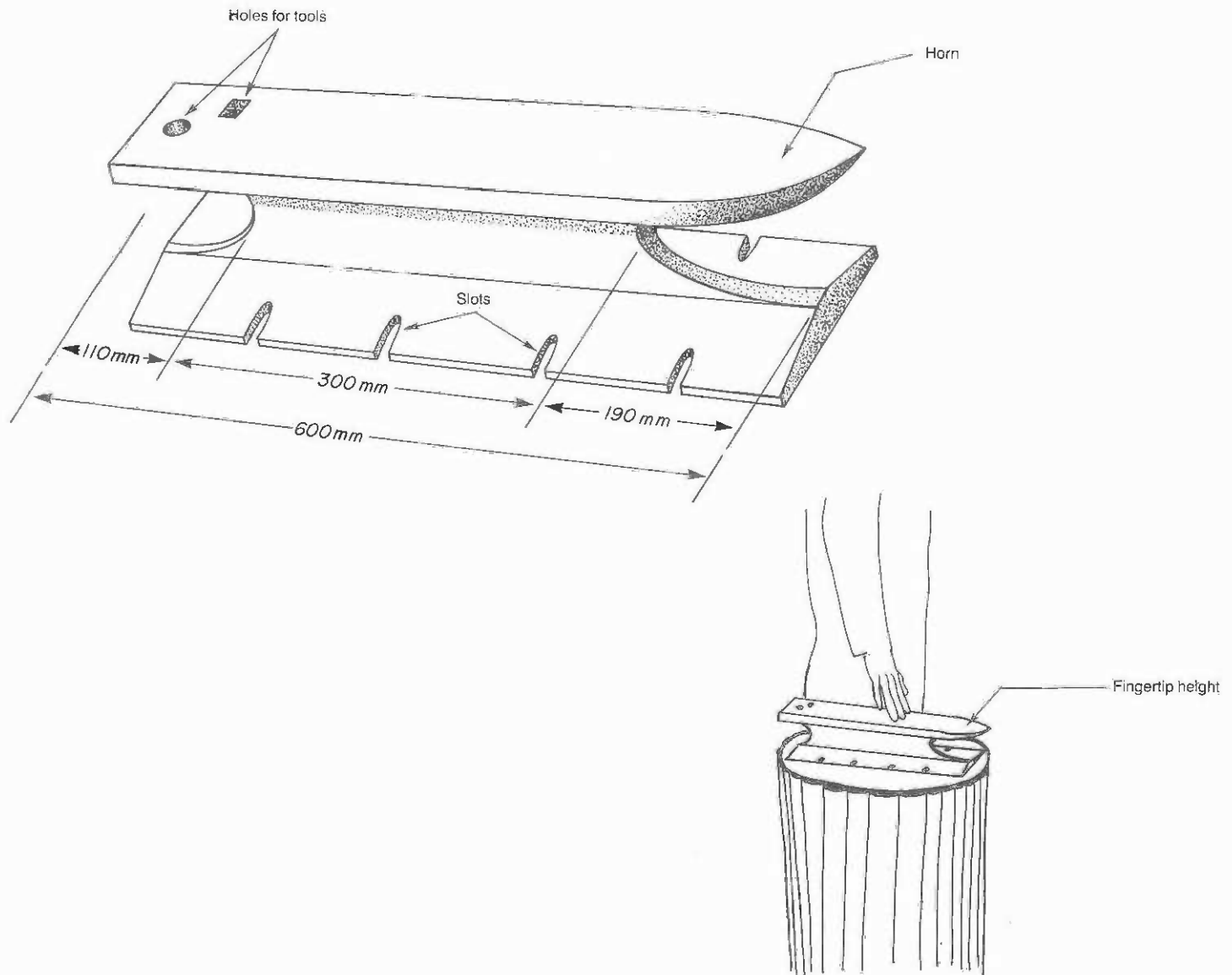

6. Anvil 2

Use

As a surface for working metal.

Material

Hardwood boards of various dimensions, a section of used railroad rail about 600 mm long, 8 bolts with nuts, 20 nails or screws.

Instructions

For the frame of the anvil cut the hardwood boards using the dimensions below. Assemble the frame as shown. The base boards and the uprights are bolted together. The sides and the bottom board are attached with nails or screws. The sides and the bottom form a tray to hold tools. Invert the section of railroad rail and place it upside-down in the slots in the top of the frame. The working surface of the anvil should be at fingertip height.

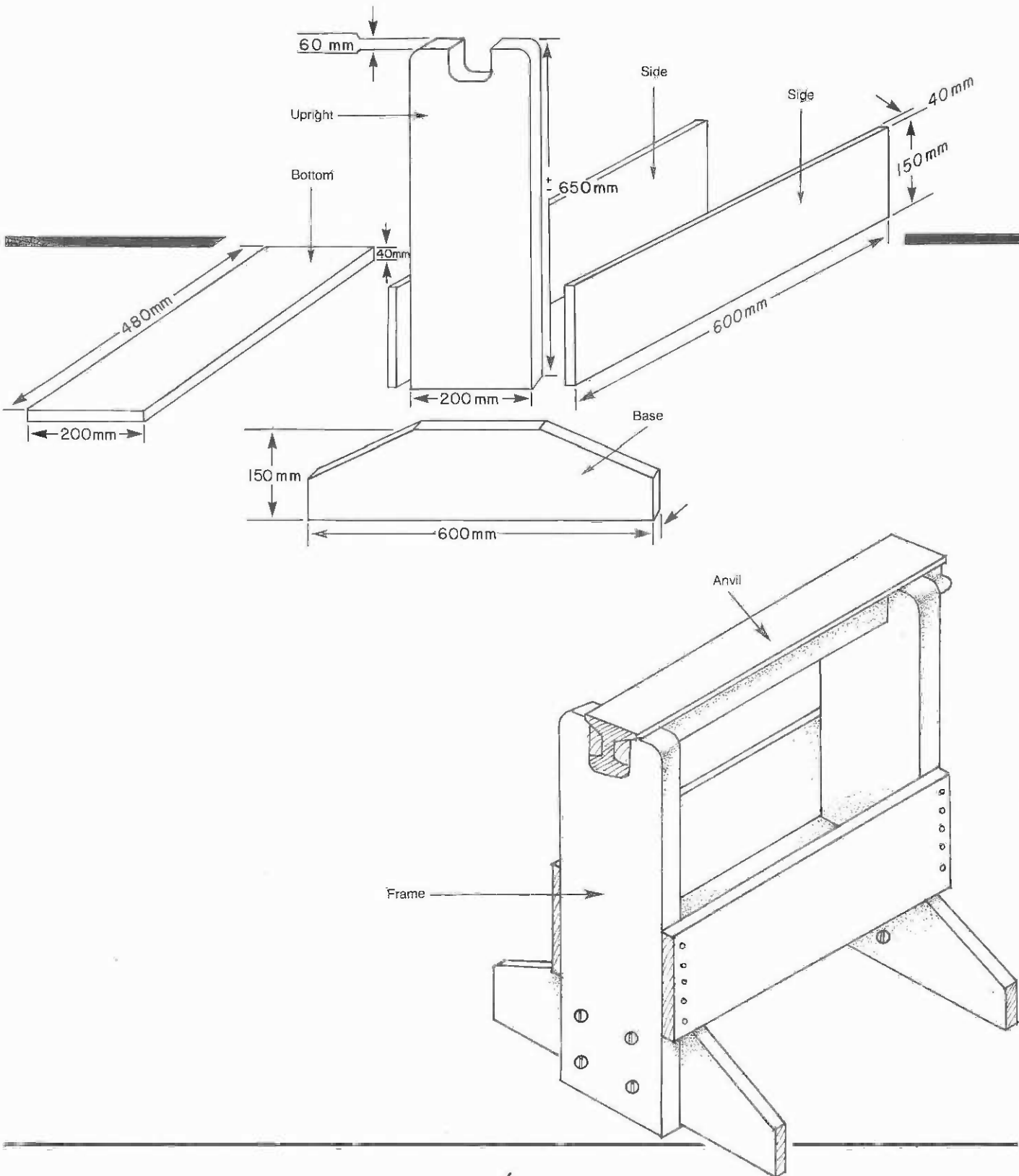

7. Wire twister

Use

To twist single-strand wire into four- or six-strand cable.

Material

1 piece of flat iron 500 x 100 x 7 mm (1), 1 piece of flat iron 850 x 150 x 7 mm (2), 1 iron rod 20 mm \varnothing x 450 mm (3), 1 iron rod 10 mm \varnothing x 600 mm (4), a wooden handle, 8 heavy nails.

Instructions

Shape the two pieces of flat iron to form the base pieces (1 and 2). Form a hook at one end of the 20-mm iron rod (3). Drill holes for the nails to fasten the base pieces when the tool is being used. Drill holes for the twisting shaft in the larger base piece and insert the shaft. Cut the 10-mm iron rod in three pieces. Use one piece for the crank (4) and the remaining two pieces for the ring and pin. The crank can be welded to the twisting shaft or the shaft can be threaded to attach the crank with a nut. Attach the wooden handle to the crank. Attach the ring and pin to the shorter base piece.

To use this tool, nail the base pieces to tree stumps as shown. Then, fasten the strands of wire to be twisted between the ring and pin and the hook on the twisting shaft. When the crank is turned the strands of wire are twisted. The strain on all strands of wire twisted in this way will be equal.

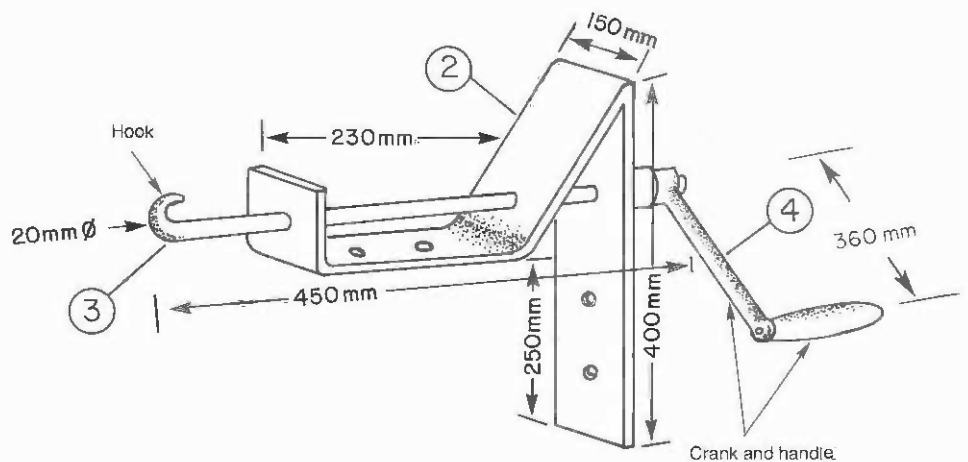
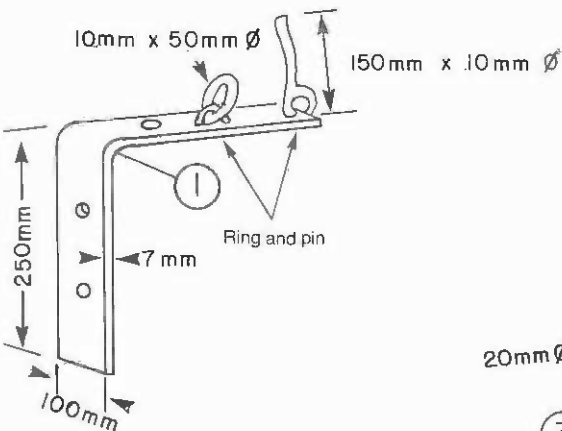

8. Stake driver

Use

To drive long, thin stakes into the ground.

Material

A piece of pipe 80 mm \varnothing x 200 mm, a wooden wedge of appropriate length and thickness, a length of chain.

Instructions

Cut the tapered wedge holder from the piece of pipe as shown. Fasten the wedge holder to the stake at about waist height using the length of chain. Put the wooden wedge in the wedge holder and tap in the stake using a wooden hammer or mallet. To keep the wooden wedge from splitting, strengthen the top edge of the wedge with a metal band.

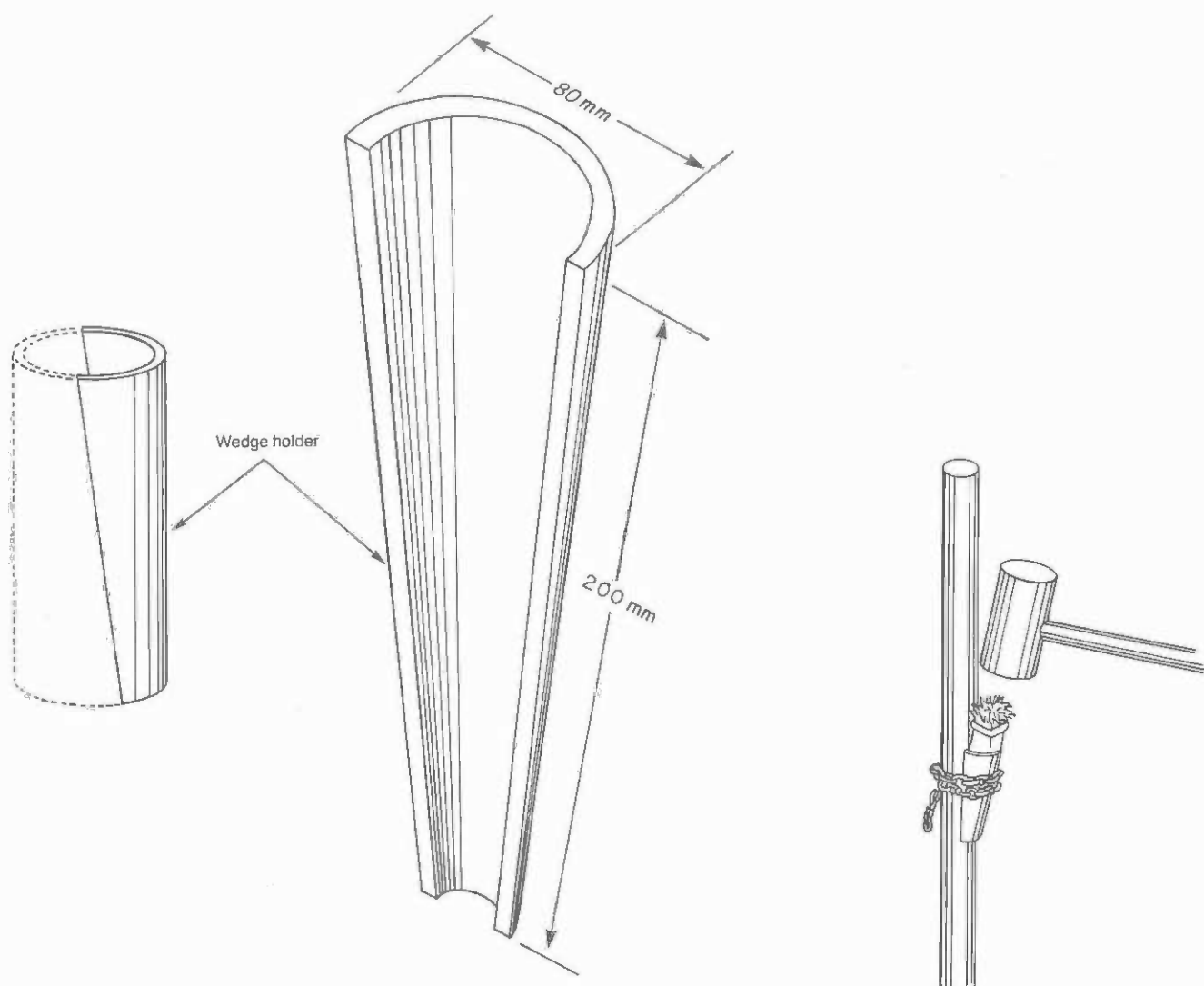

9. Post driver

Use

To drive posts into the ground.

Material

A piece of pipe 150 mm \varnothing x 750 mm, a threaded cap 150 mm \varnothing x 20 mm or a piece of iron 150 mm \varnothing x 20 mm, iron rods 20 mm \varnothing x 830 mm.

Instructions

Close one end of the piece of pipe to form the shaft. This can be done either by threading the inside of one end of the pipe and screwing in a threaded cap or by welding a round piece of iron to one end of the pipe. Bend the two iron rods to form handles and weld them to opposite sides of the pipe. Put the post driver on top of the post and pound it into the ground as shown. This tool can be used by one or two people.

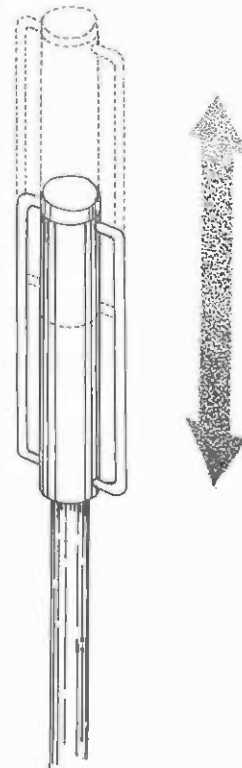
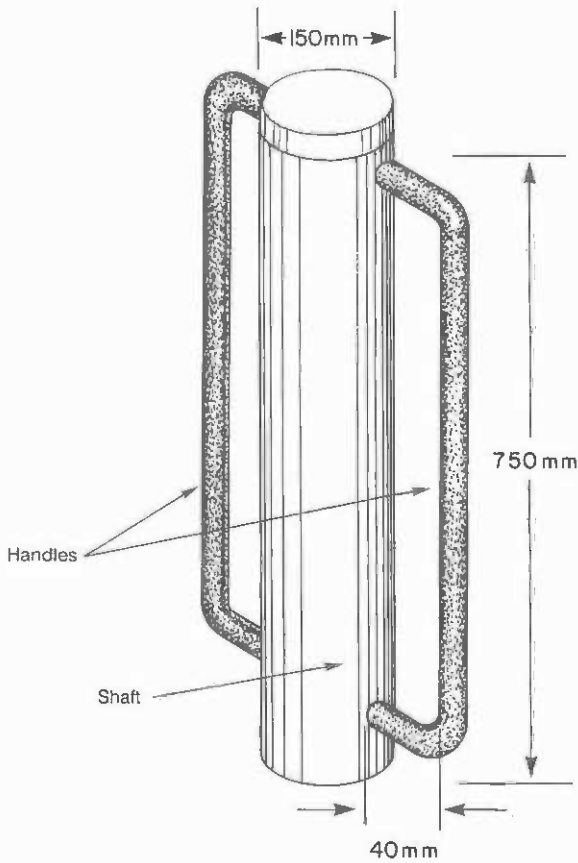

10. Water level

Use

To sight horizontal lines.

Material

A piece of clear plastic tube of appropriate length (up to 30 m long depending on the use), 2 corks to fit the tube, 2 straight pieces of wood 1 500 x 40 x 20 mm, 2 light metal clamps with thumbscrews, 4 screws.

Instructions

Attach a clamp to each end of the plastic tube. Screw one clamp to each of the two pieces of wood. Fill the tube with water so that the level of the water is a little below the ends of the tube. Put a cork in the end of each tube to keep the water from spilling out. When the tube is stretched out and the pieces of wood are upright, the water at each end will be at the same level. You can use this tool to sight horizontal lines as shown below.

Note

Use boiled water to eliminate air bubbles. If the water is coloured with dye it will be easier to sight along the level.

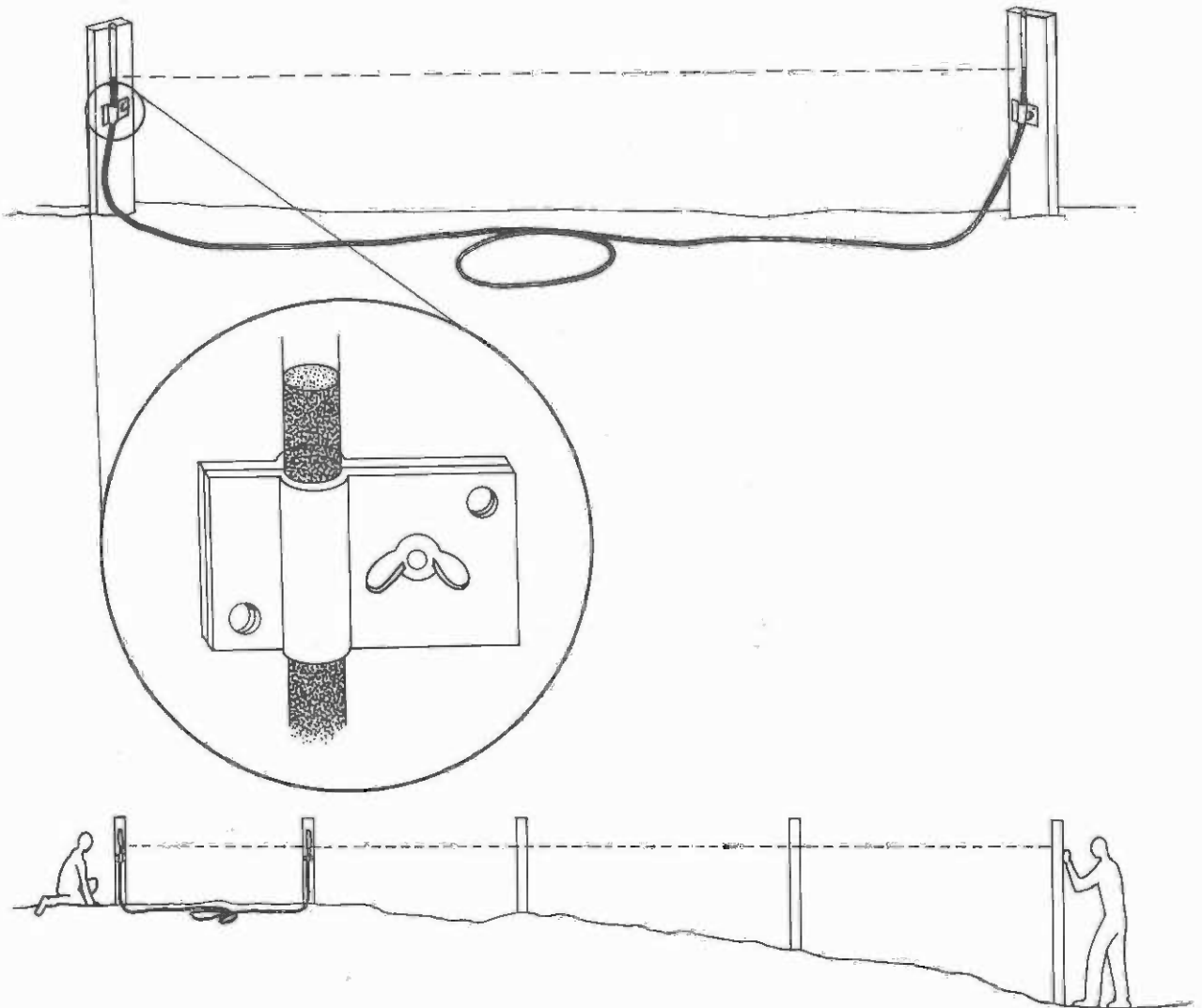

11. Earth scraper

Use

To move earth or dig ditches.

Material

A used oil drum, 2 wooden poles 40 mm Ø x 900 mm, nails, 2 threaded eyes with nuts, 2 lengths of rope.

Instructions

Cut the oil drum as shown by the dotted lines and roll the upper edges on both sides. Insert the wooden poles in the rolled part of the drum to form handles. Nail the handles in place. Drill a hole through the front part of each handle and the drum. Bolt one of the threaded eyes in each hole. Insert a length of rope in each eye to attach to a draft animal. One person can guide the scraper using the handles while the animal pulls.

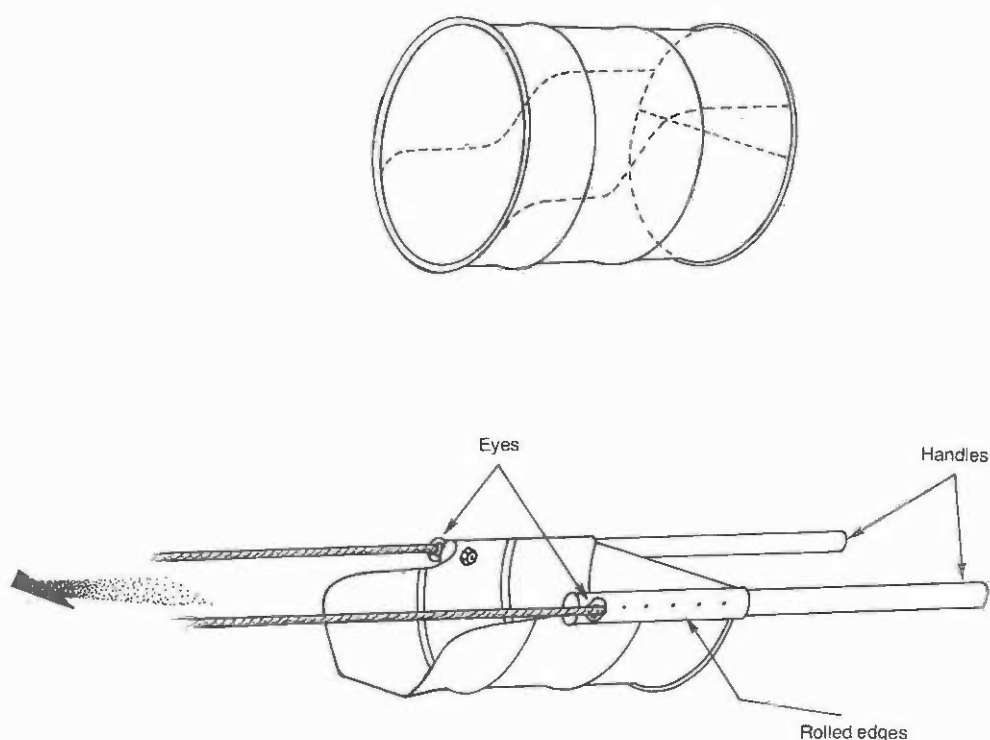

12. Axe hoe

Use

To cut roots, stumps and brush or to dig into the ground.

Material

Pieces of tempered steel (such as from a used truck spring) of various dimensions, a wooden handle of appropriate size.

Instructions

Cut and shape the axe and hoe blades and shape a tapered eye for the centre of the tool using the dimensions below. Weld the two blades and the eye together as shown. Sharpen and harden the blades. Shape the wooden handle, insert it into the eye and attach it as you would any axe handle. This is a useful tool for clearing land or building trails or roads.

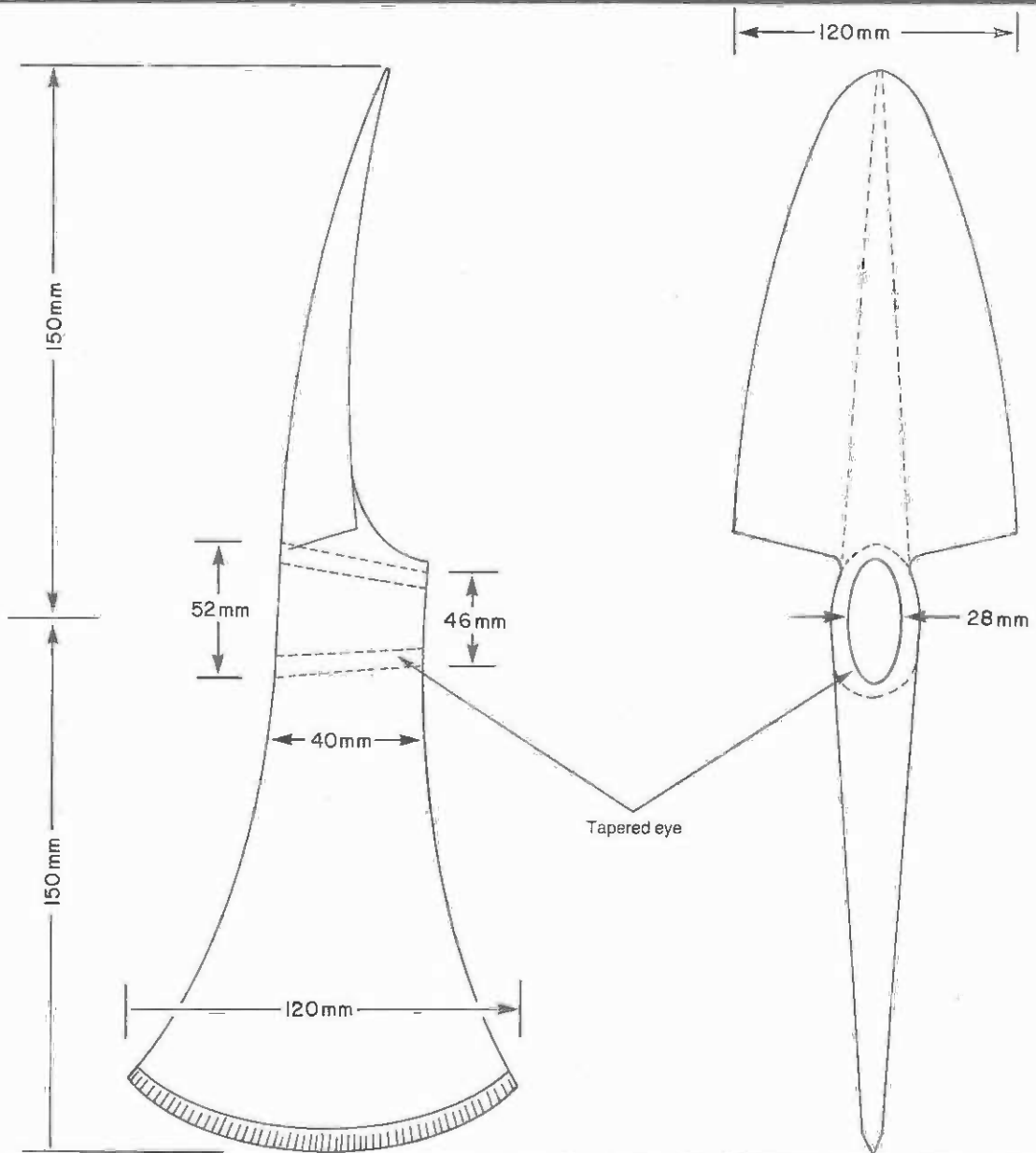

13. Stump puller

Use

To pull tree stumps out of the ground.

Material

A piece of log 450 mm \varnothing x 750 mm (for the roller), a piece of log 150 mm \varnothing x 2 000 mm (for the lever arm), a length of chain or cable.

Instructions

Cut or drill a hole through the roller a little less than 150 mm \varnothing and drive in the lever arm. Attach the chain or the cable to the stump to be pulled and pass it around the base of the lever arm. To pull the stump, rotate the lever arm in the direction shown. If a stump is hard to pull, dig away the earth and cut as many of the roots as you can.

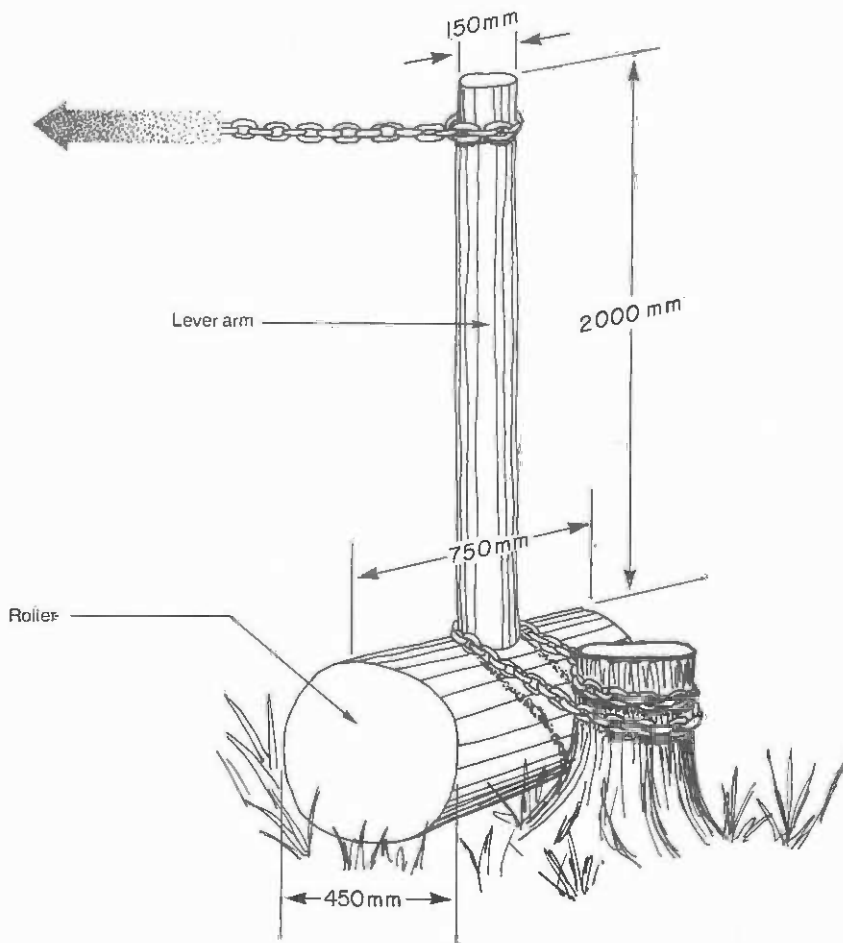

14. All-purpose hook

Use

To anchor a pulley block.

Material

An iron bar 550 x 60 x 15 mm, 2 shackles with 15 mm \varnothing pins, a pulley block.

Instructions

Shape the iron bar to form a hook using the dimensions below. Drill a hole in one end of the hook and taper the other end to a point. Sharpen and harden the point.

Attach the shackles and the pulley block as shown. The hook can be left with the pulley block connected so that it is always ready to be used. When this tool is hooked to a tree stump, it is useful in pulling vehicles or other loads.

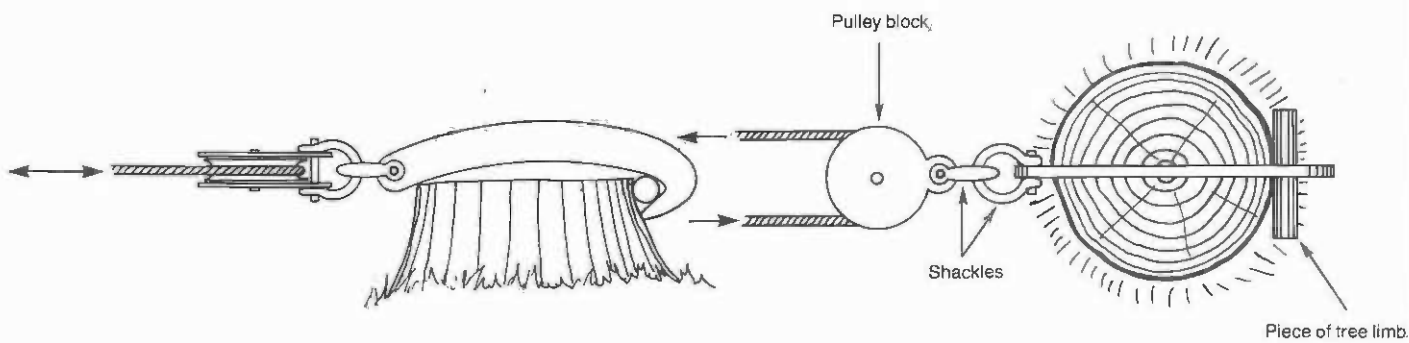
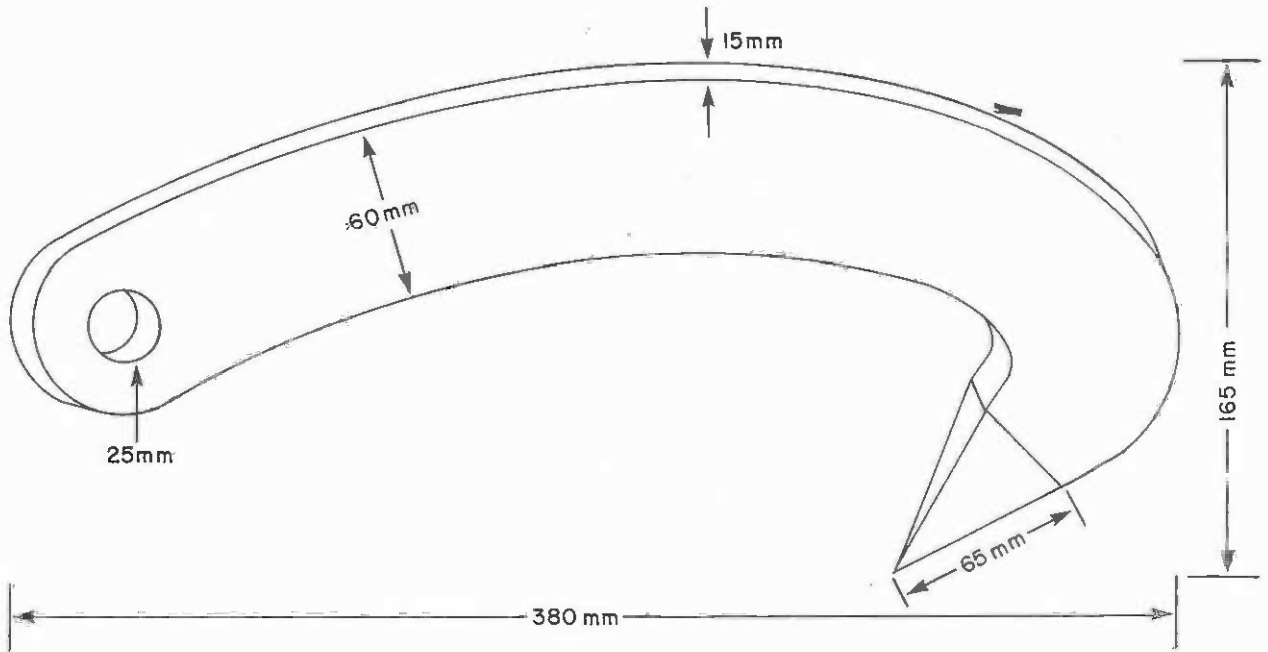

15. Ground anchor

Use

To anchor light guy wires.

Material

A piece of flat iron 1 000 x 40 x 5 mm.

Instruction

Heat and shape or cold bend the piece of flat iron to form the anchor using the dimensions below. Shape a round open eye at one end and sharpen the other end so that it can be easily driven into the ground. This tool offers the greatest resistance with horizontal pull. As the angle of pull increases, the bend of the anchor presses into the ground.

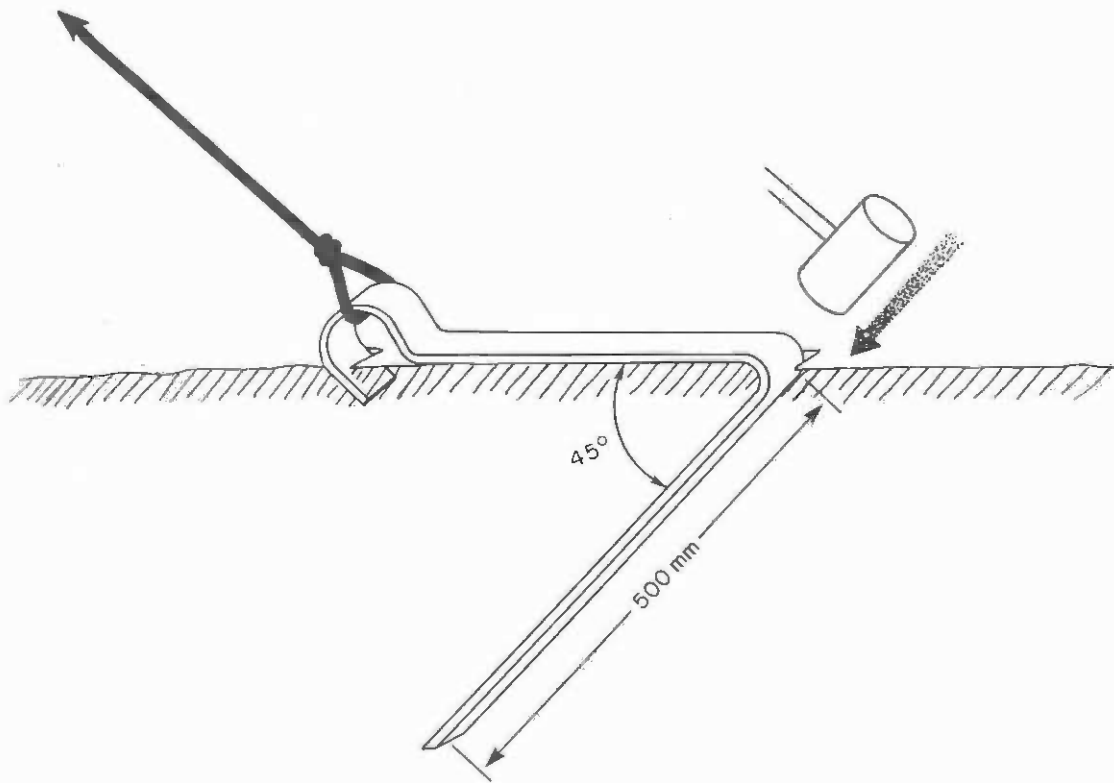

16. Use of pulley blocks

Use

To increase pulling force using pulley blocks.

Material

1 or more pulley blocks.

Instructions

The diagrams below show how to use pulley blocks in various ways to increase pulling force and make pulling work easier.

Note

In any pulley combination the mechanical advantage is equal to the number of strands supporting the movable block less friction.

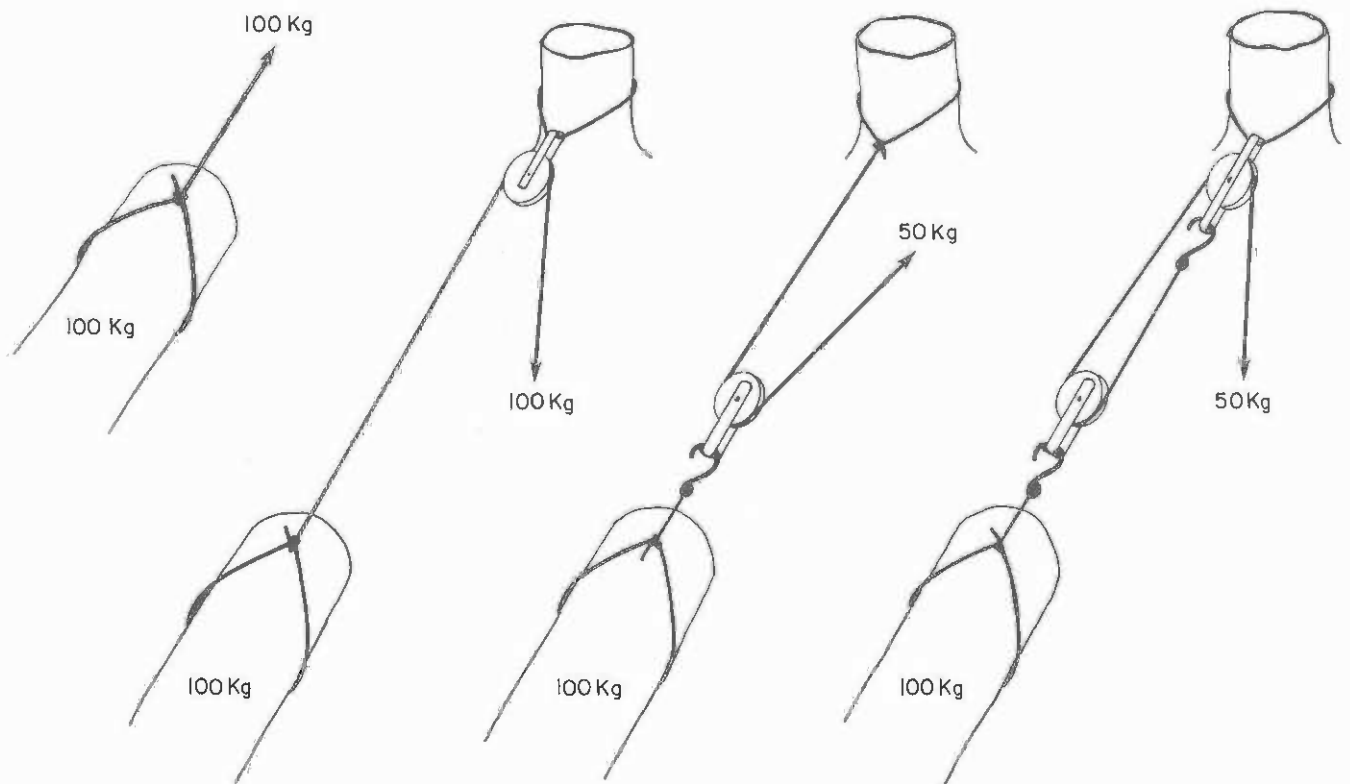

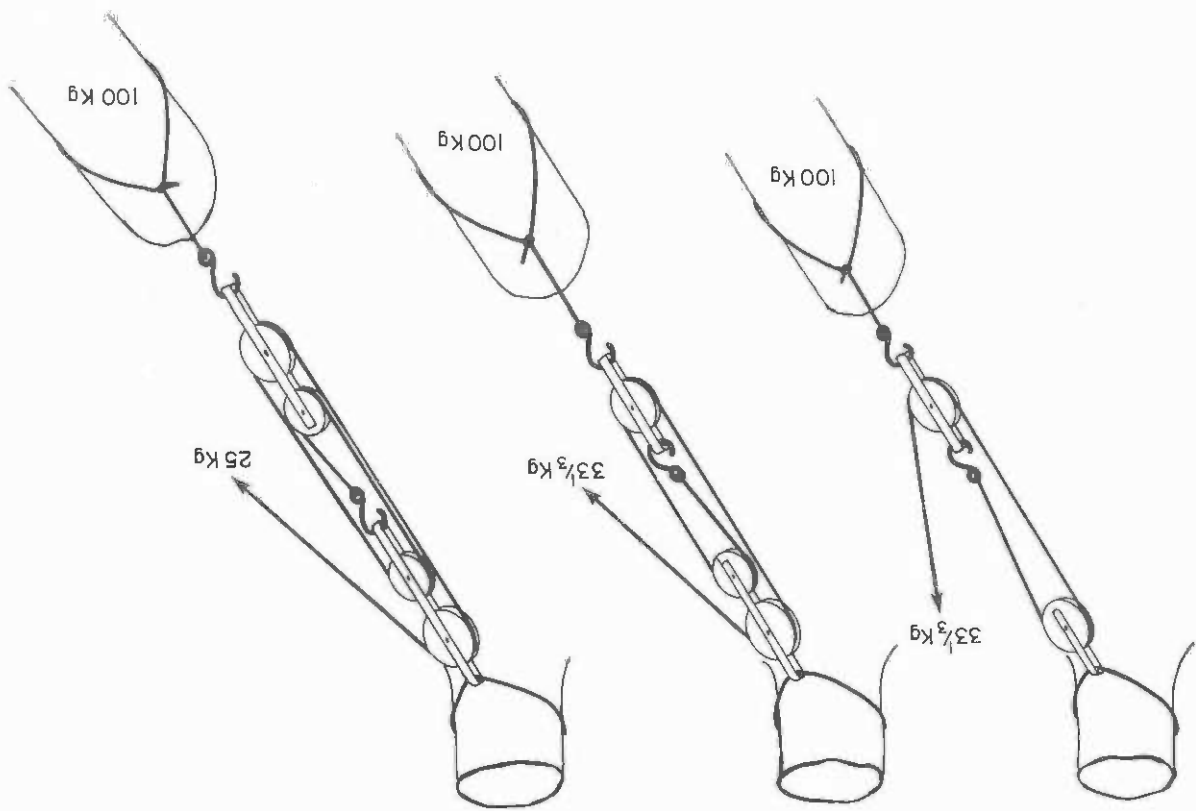

17. Brush hook

Use

To clear light brush.

Material

A piece of tempered steel (such as from a used car or truck spring), a piece of pipe 35 mm \varnothing x 50 mm, 2 bolts 5 mm \varnothing x 45 mm with nuts, a piece of hardwood 36 mm \varnothing x 670 mm.

Instructions

Shape the blade using the dimensions below and weld it to the piece of pipe as shown. Shape the piece of wood to form a handle and insert it into the pipe. Drill two holes through the handle and the pipe and bolt them together. Sharpen the blade on both sides by grinding or filing.

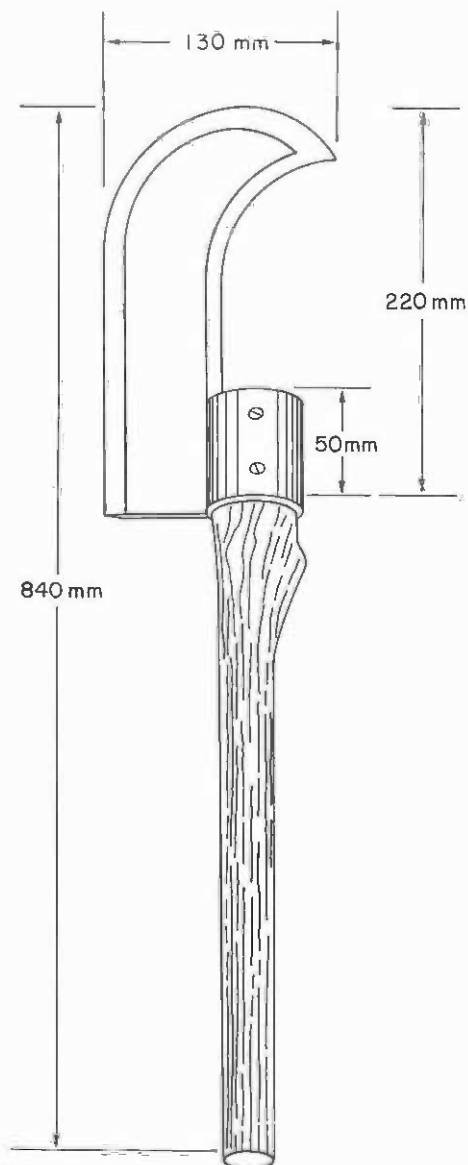

18. Machete

Use

To clear light brush.

Material

A section from an old crosscut saw, 2 pieces of hardwood, 3 rivets 5 mm \varnothing x 25 mm, a piece of rope or a leather thong.

Instructions

Shape the blade using the dimensions below. Shape the two pieces of wood to form the handles. Drill three holes through the blade and the handles and rivet them together. Sharpen the inside of the blade by grinding or filing. Drill a hole in the end of the handle and attach the rope or leather thong.

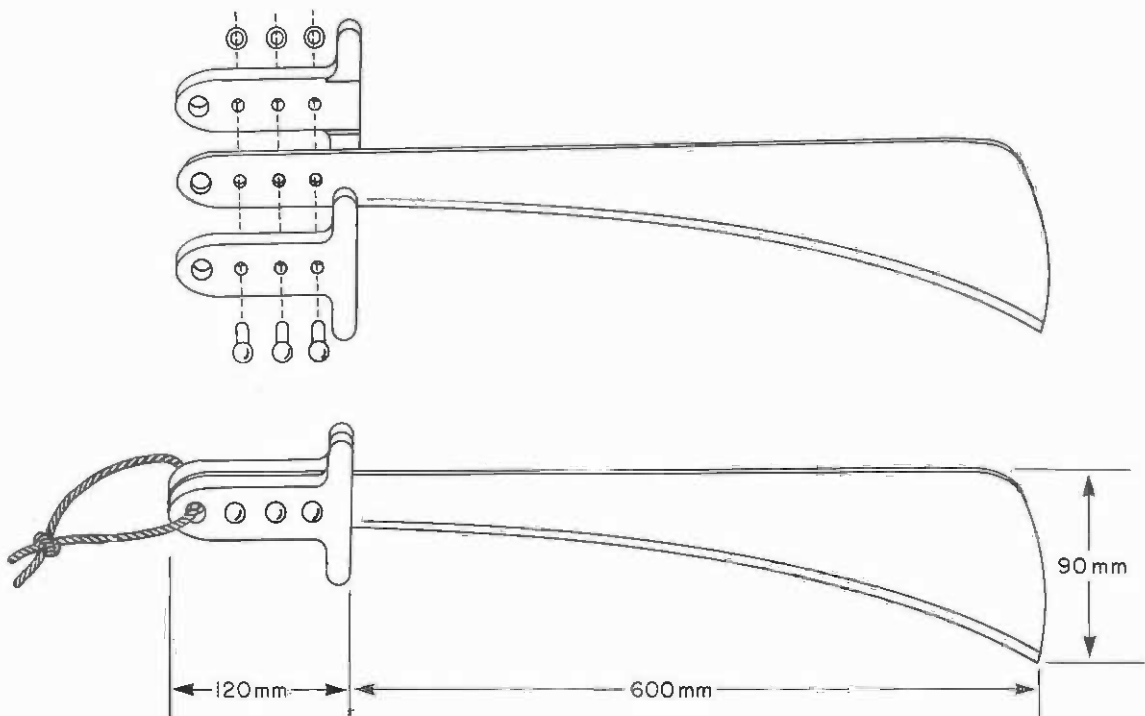

19. Girdling tool

Use

To remove a strip of bark from a tree so that it will die.

Material

A piece of mild steel rod 10 mm \varnothing x 690 mm, a piece of tempered steel 90 x 35 x 3 mm, a piece of wood 50 mm \varnothing x 600 mm.

Instructions

Bend the steel rod in two so that the ends are about 80 mm apart. Bend both sides of the rod at the midpoint to form an angle of about 145°. Shape the piece of tempered steel to form the blade as shown and weld it between the ends of the rod. Sharpen the inner edge of the blade by grinding or filing. Place the piece of wood through the loop of the rod and pull it around the tree to remove a strip of bark.

Note

This tool is useful to kill unwanted or inferior trees where removal by felling could cause damage to trees nearby. It can also be used before felling so that trees may season in place and lose part of their moisture.

