

APPENDIX I: AREAS SURVEYED

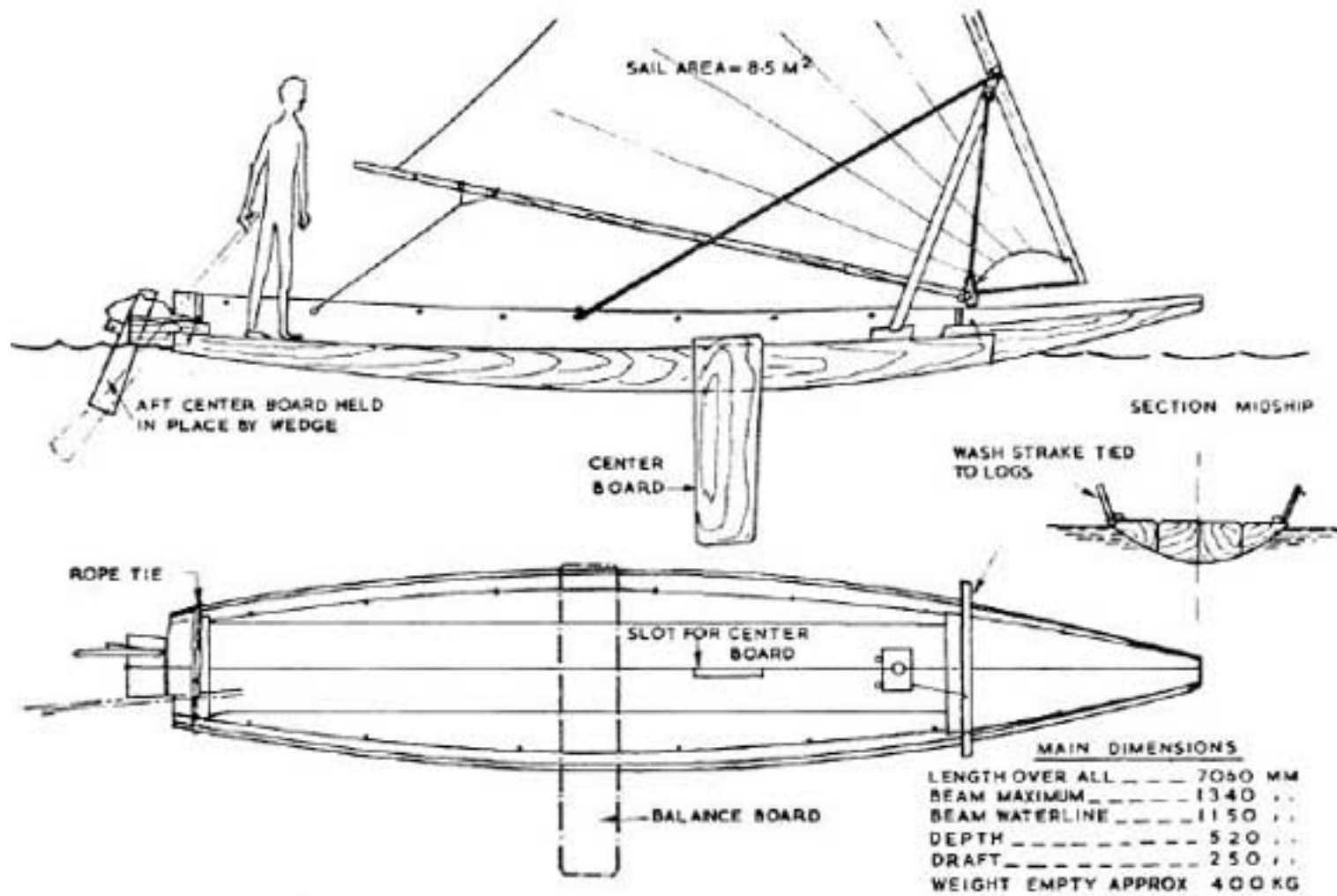

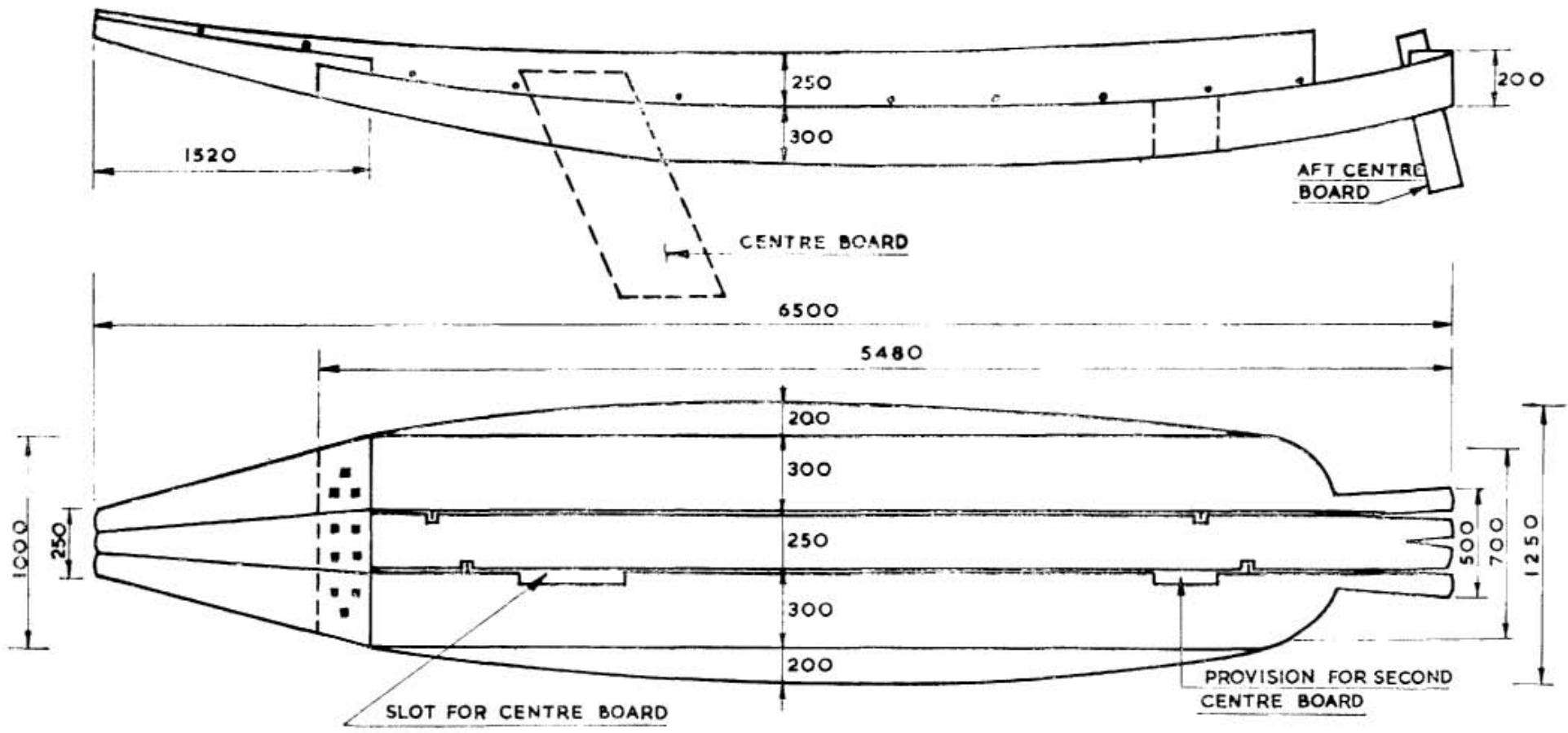

APPENDIX 2A : GENERAL ARRANGEMENT - ANDHRA PRADESH FOUR-LOG BOAT KATTUMARAM



APPENDIX-2B. TYPICAL ANDHRA PRADESH FIVE-LOG BOAT KATTUMARAM

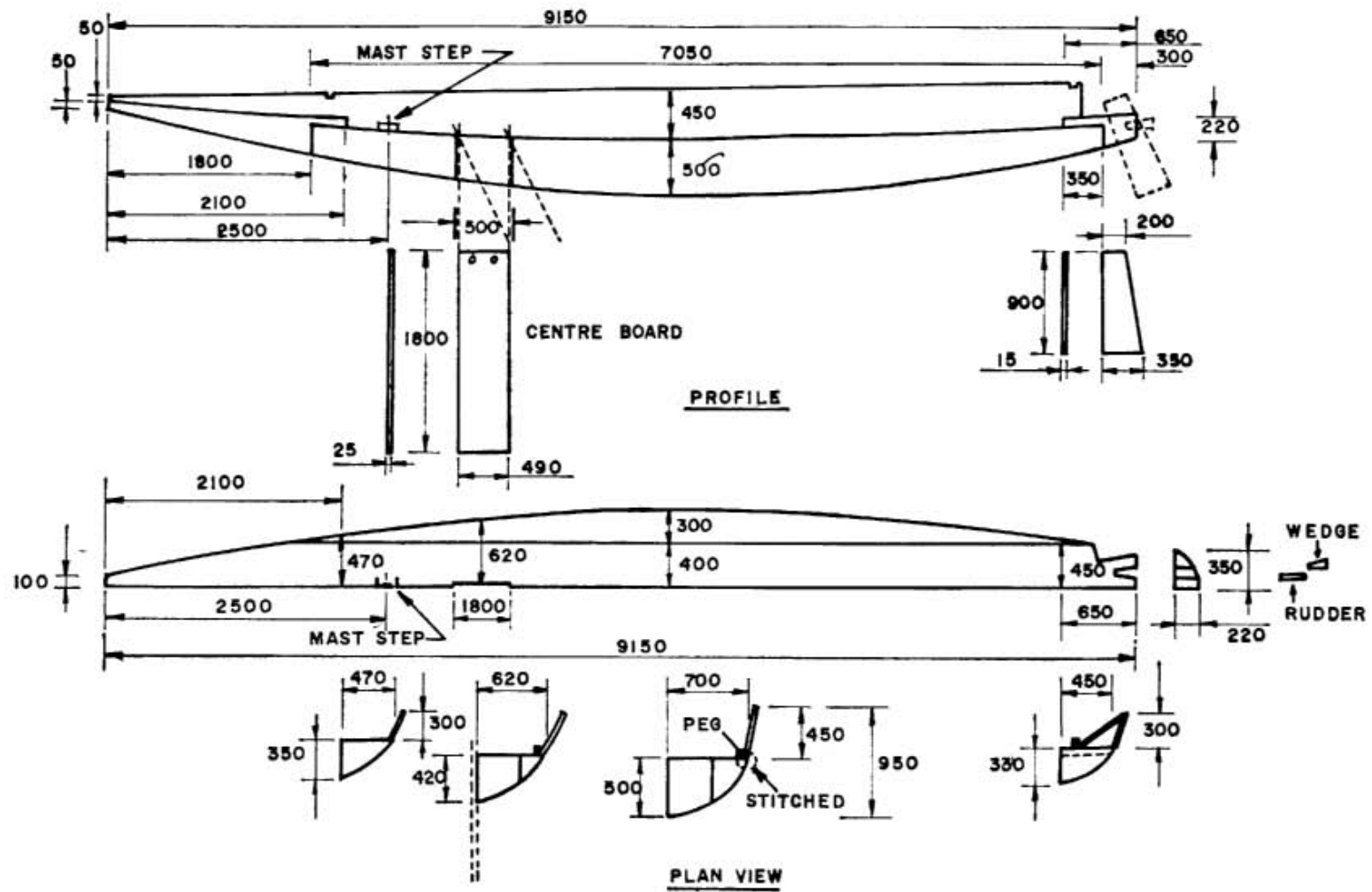

[14]

APPENDIX 2C BOAT KATTUMARAM, ANDHRA PRADESH TYPICAL DIMENSIONS OF PRINCIPAL COMPONENTS

APPENDIX .2D. BOAT KATTUMARAM, ANDHRA PRADESH. TRANSVERSE SECTIONS

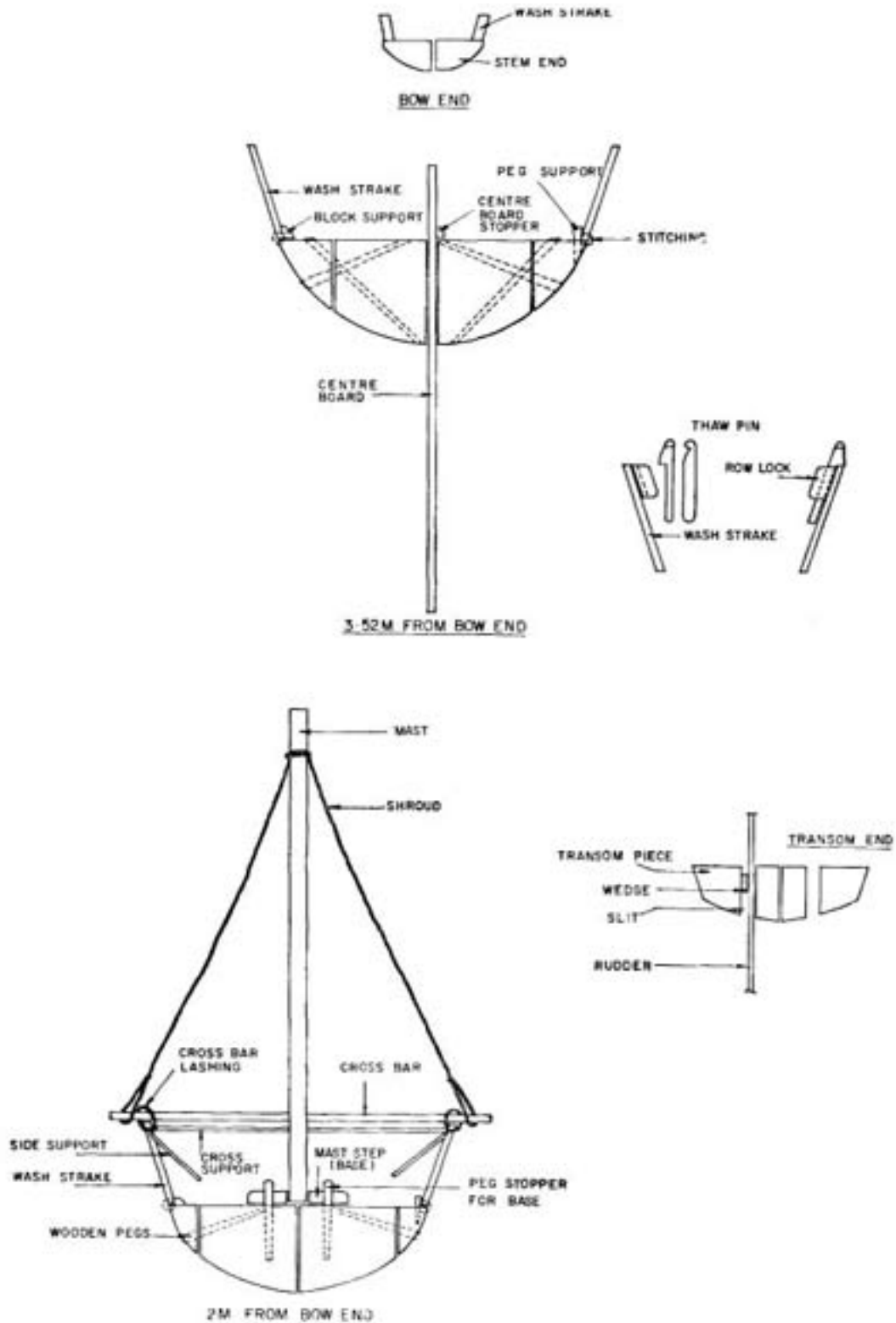

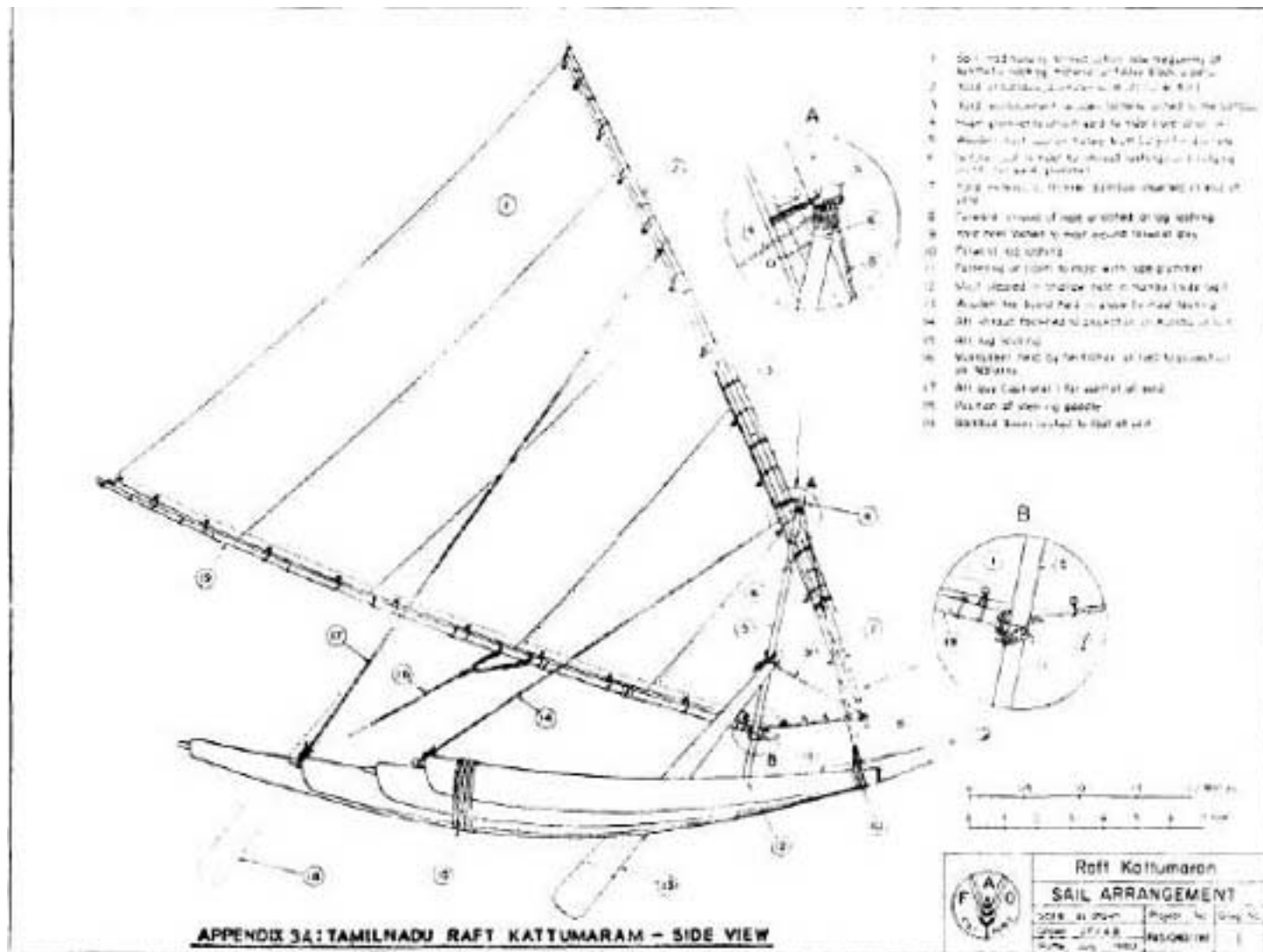

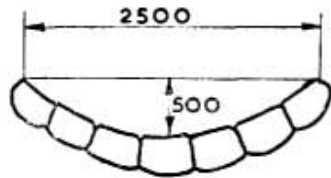
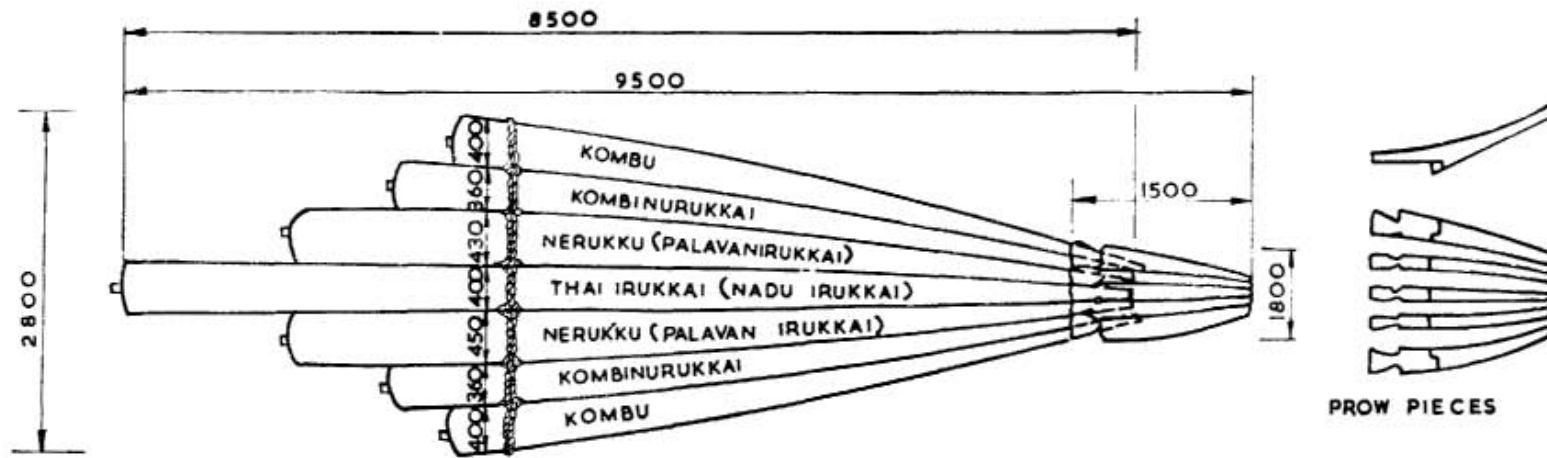

[17]

APPENDIX 3B: TYPICAL LARGE RAFT KATTUMARAM - DETAILS OF STRUCTURE

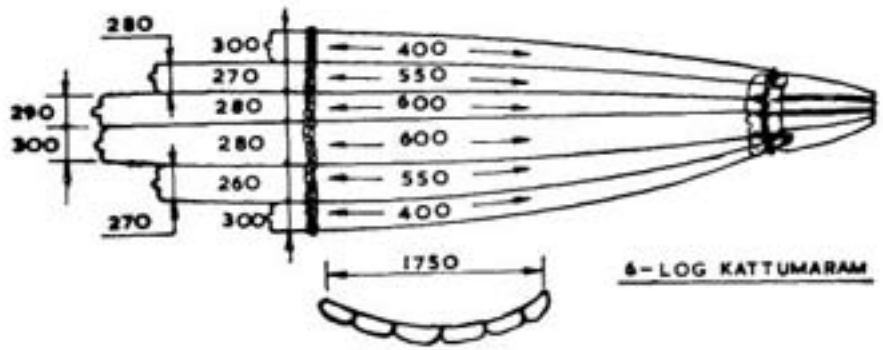
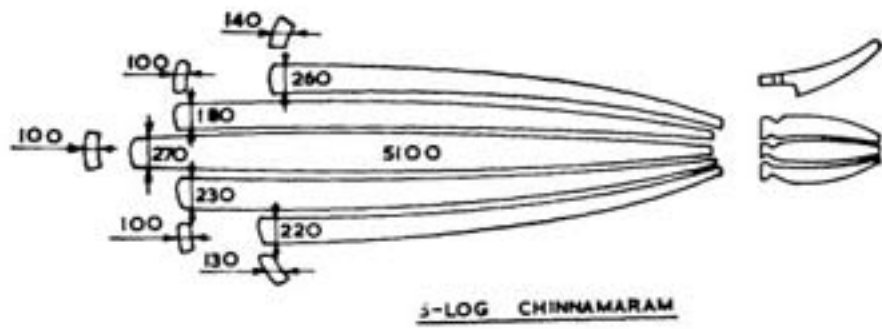
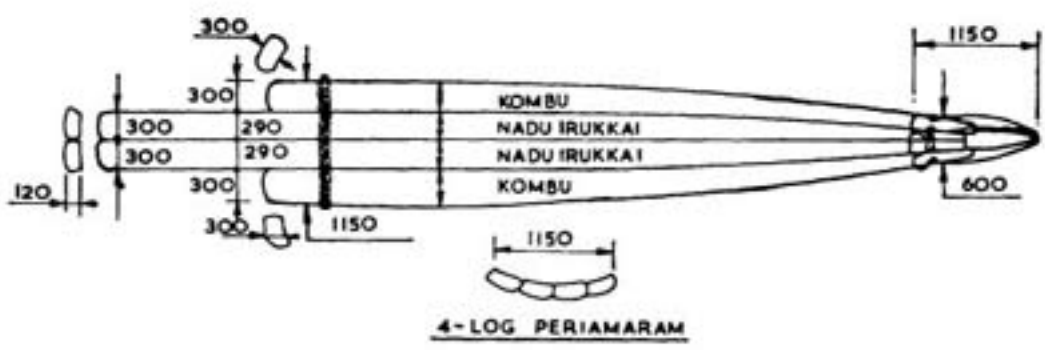
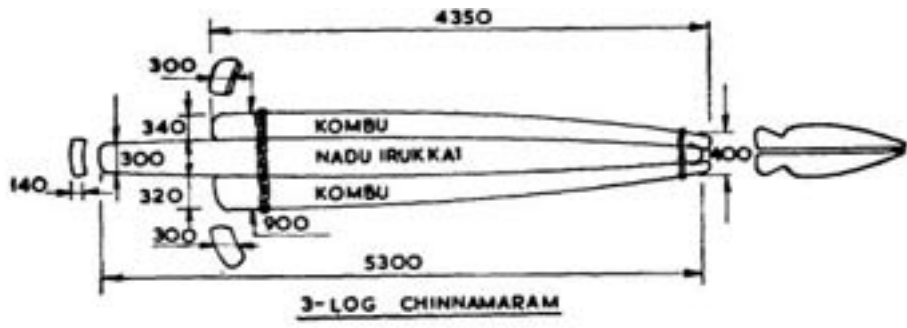

APPENDIX 3C: RAFT KATTUMARAMS-TYPICAL DIMENSIONS AND STRUCTURES

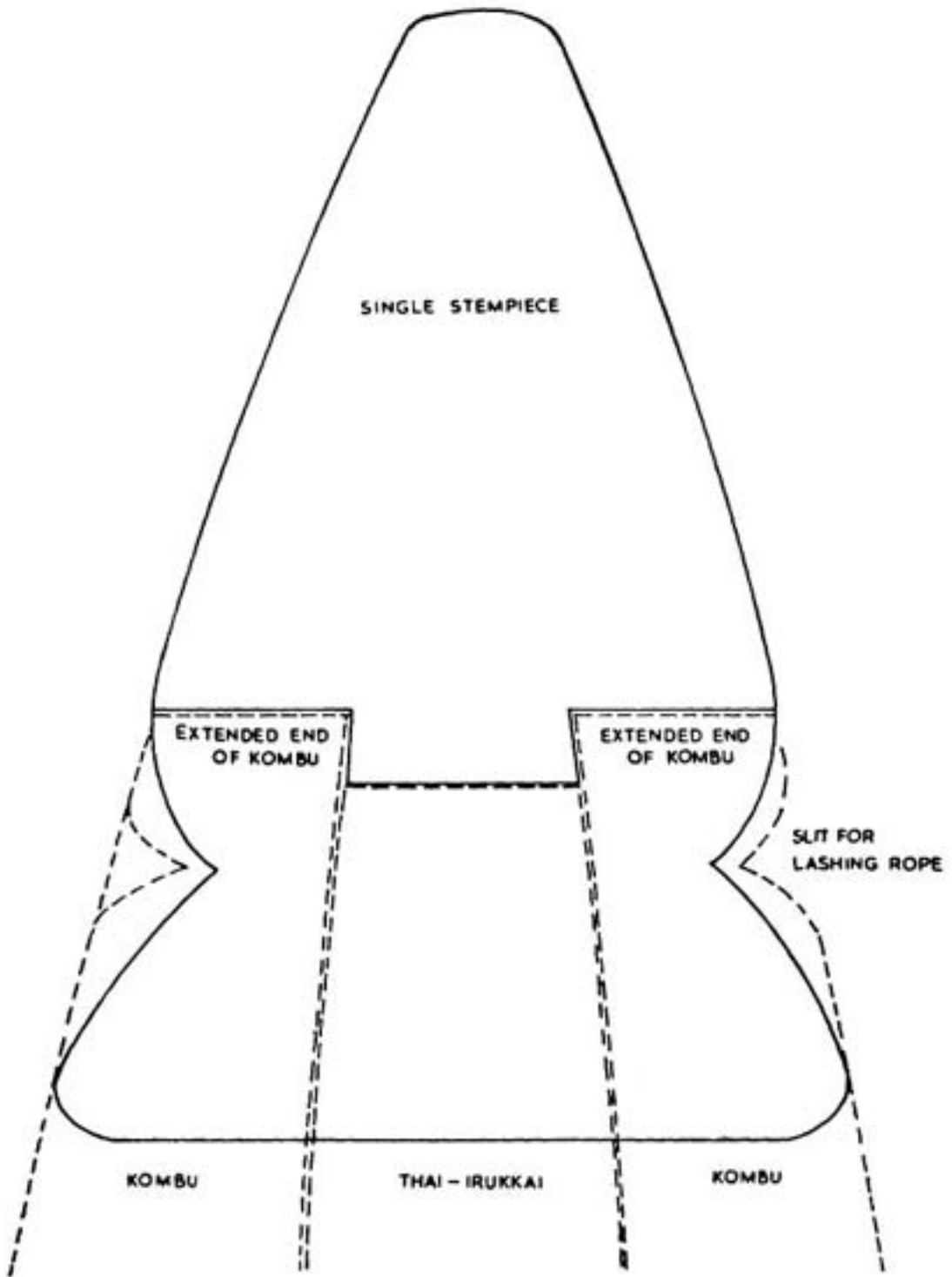

APPENDIX 3D DETAIL OF PROW PIECE FOR
A 3-LOG RAFT KATTUMARAM

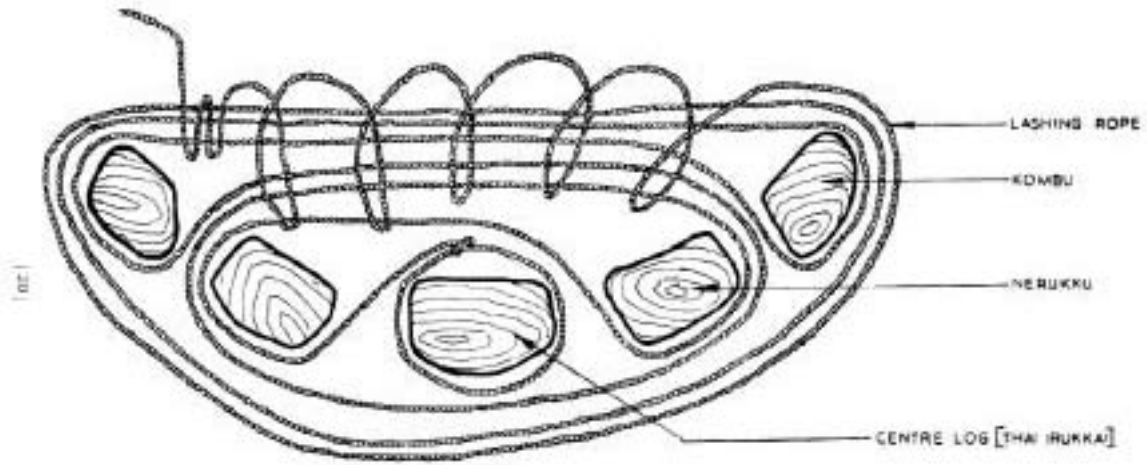

APPENDIX 3E RAFT KATTUMAR AM : LASHING SEQUENCE

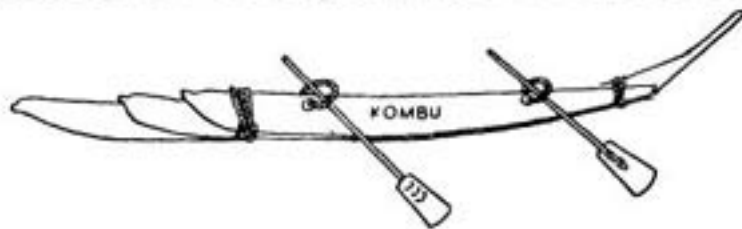
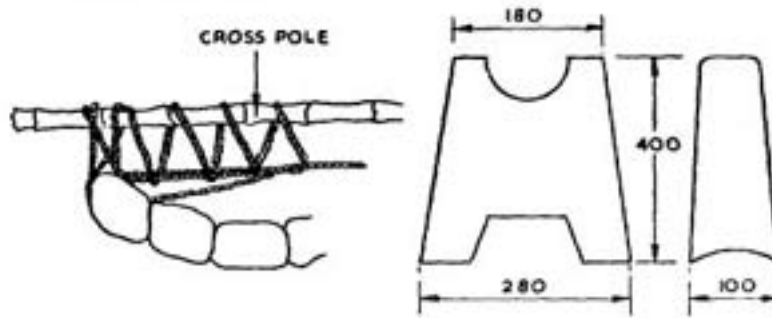
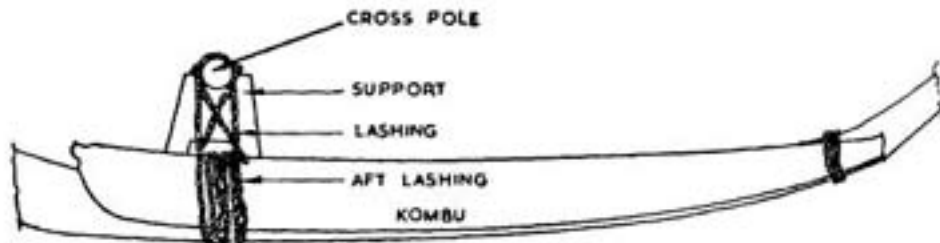
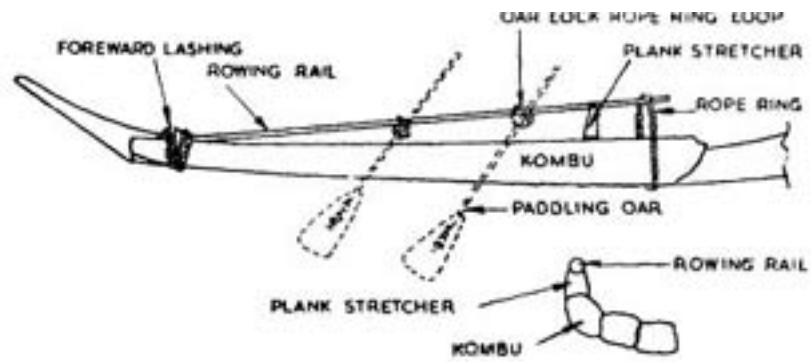

APPENDIX 3F RAFT KATTUMARAM FITTINGS

APPENDIX:4, RAFT KATTUMARAMS, OARS AND PADDLES

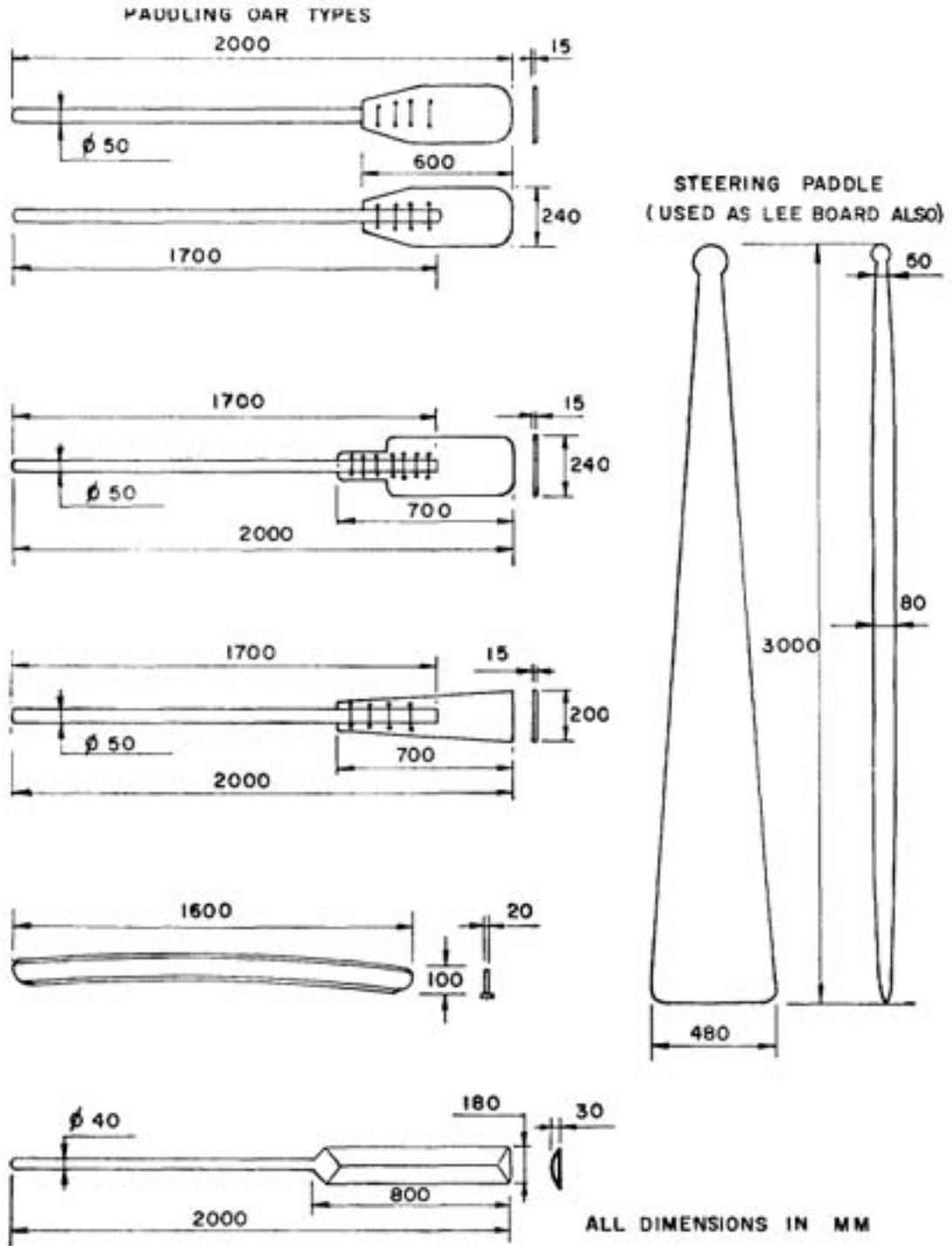

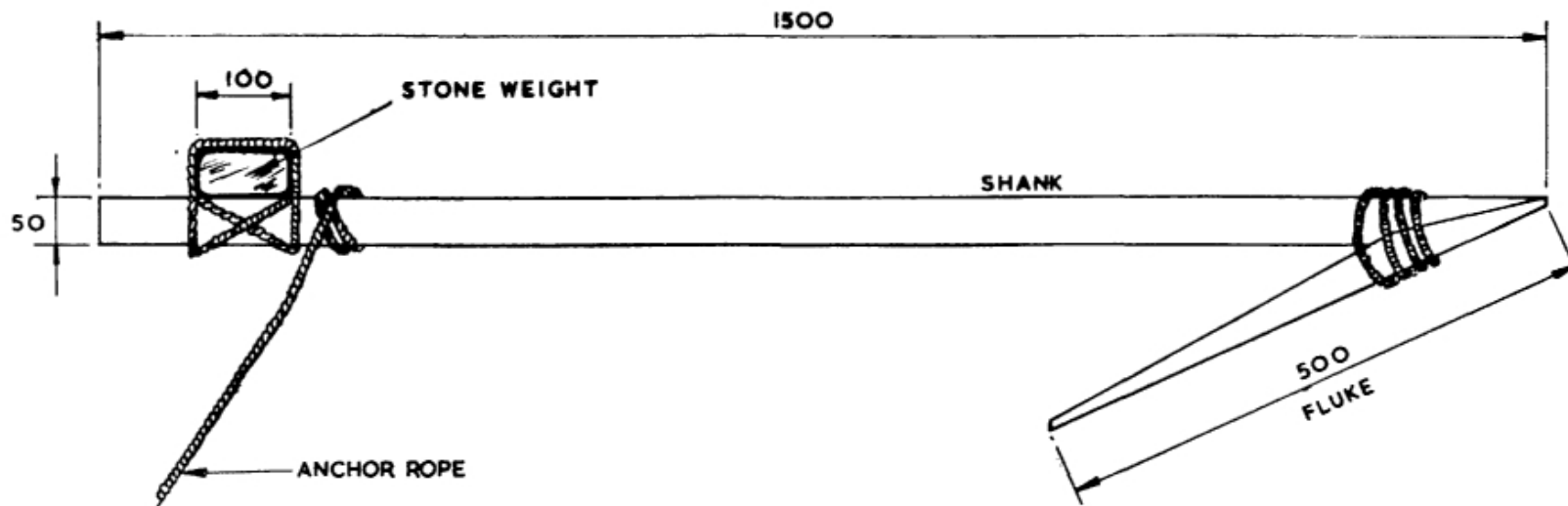

[23]

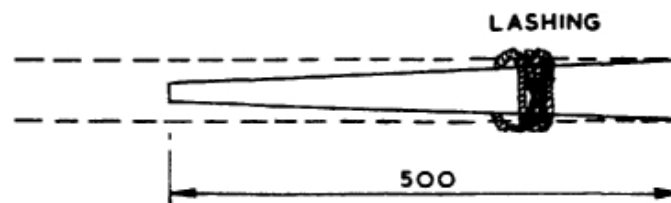

APPENDIX-5 WOODEN ANCHOR USED WITH KATTUMARAMS

APPENDIX 6A, BOAT KATTUMARAM, TAMIL NADU

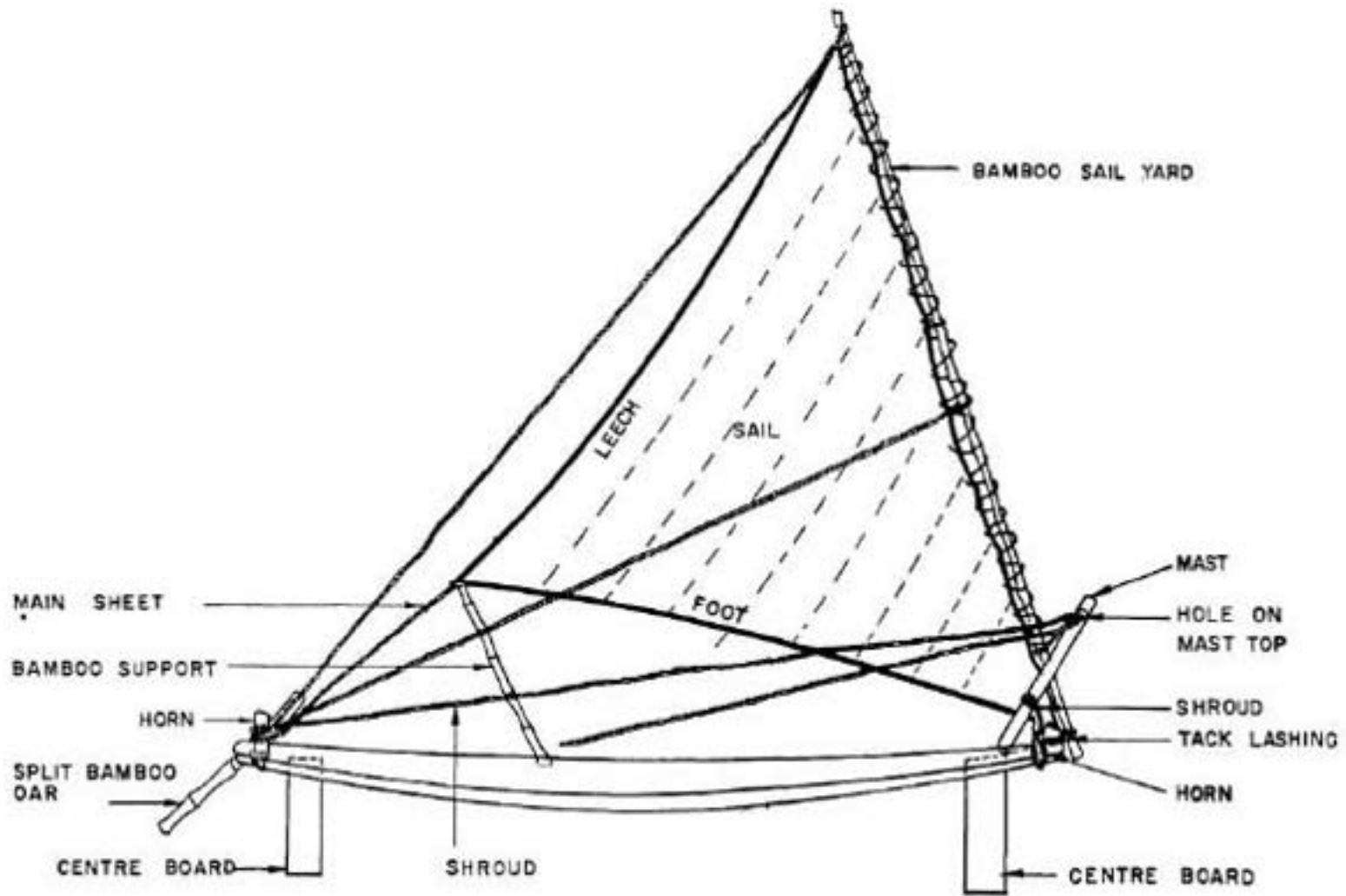

[25]

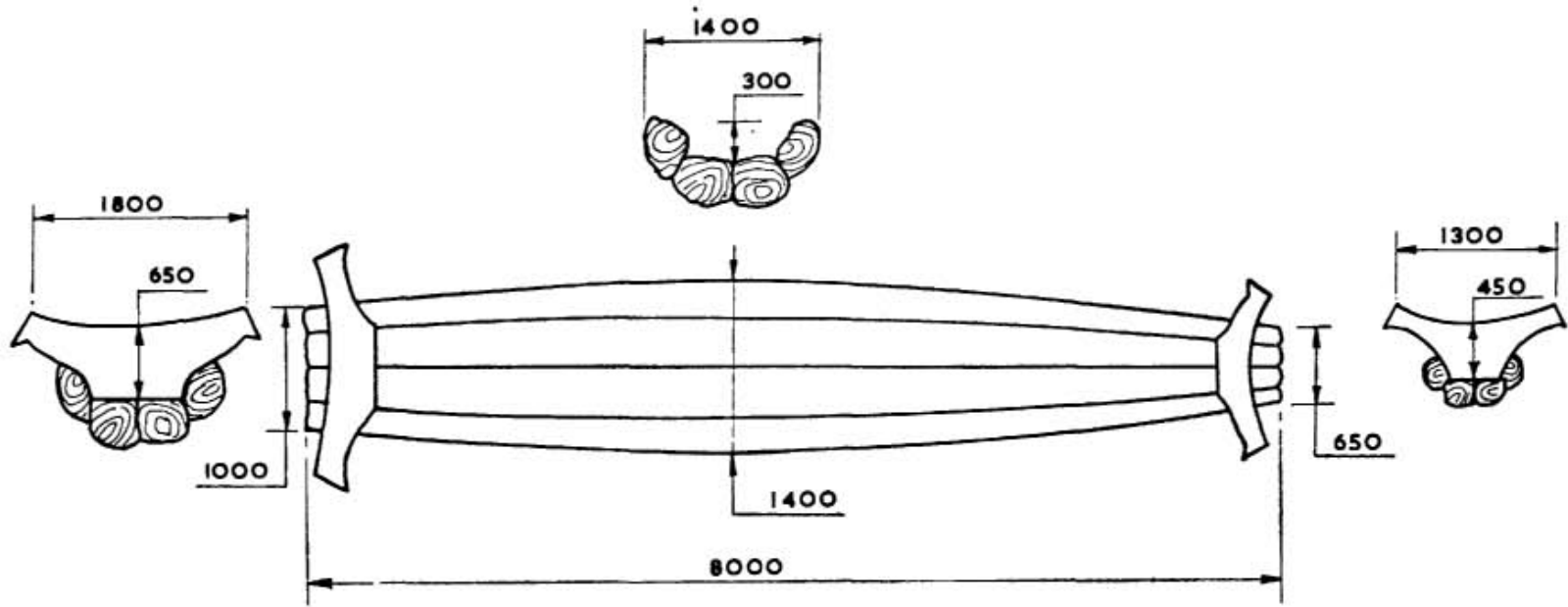

APPENDIX 6B: DIMENSIONS OF A TYPICAL TAMIL NADU BOAT KATTUMARAM

APPENDIX 6C:TAMIL NADU BOAT KATTUMARAM . DETAILS OF CONSTRUCTION

HORN ATTACHMENT TO THE LOGS ENDS



ARRANGEMENT FOR STEPPING MAST IN THE FORWARD END

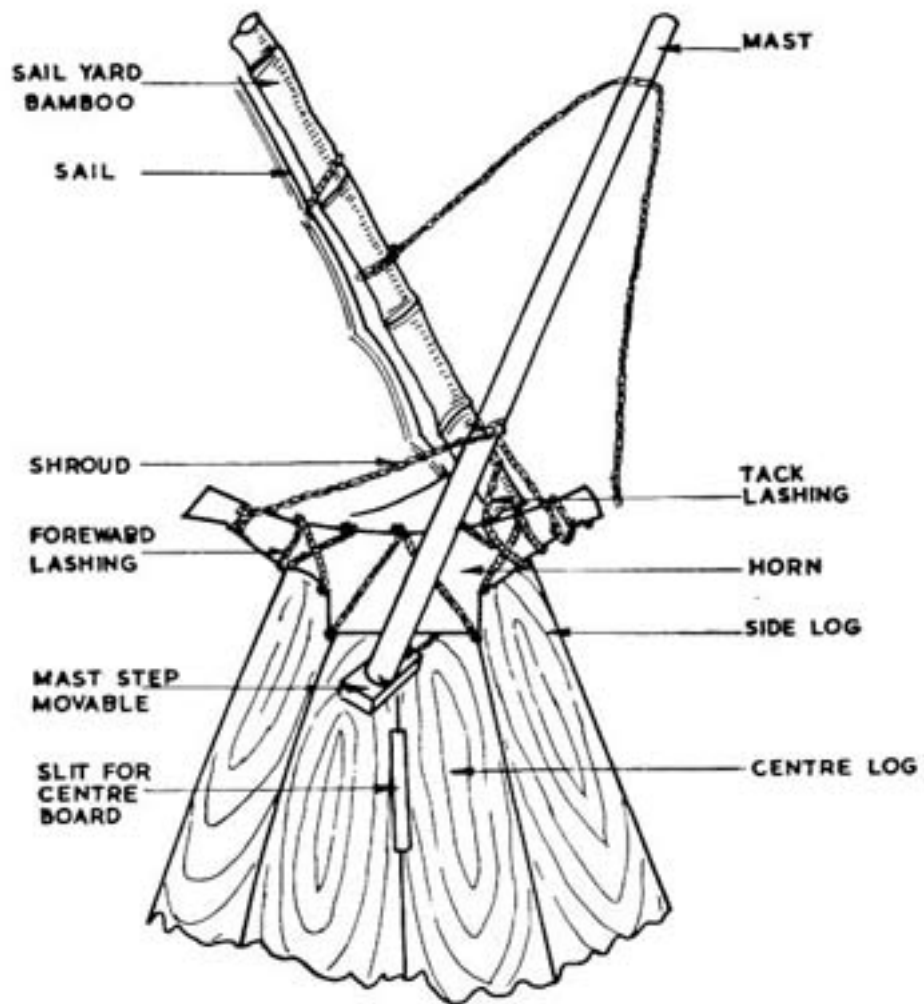

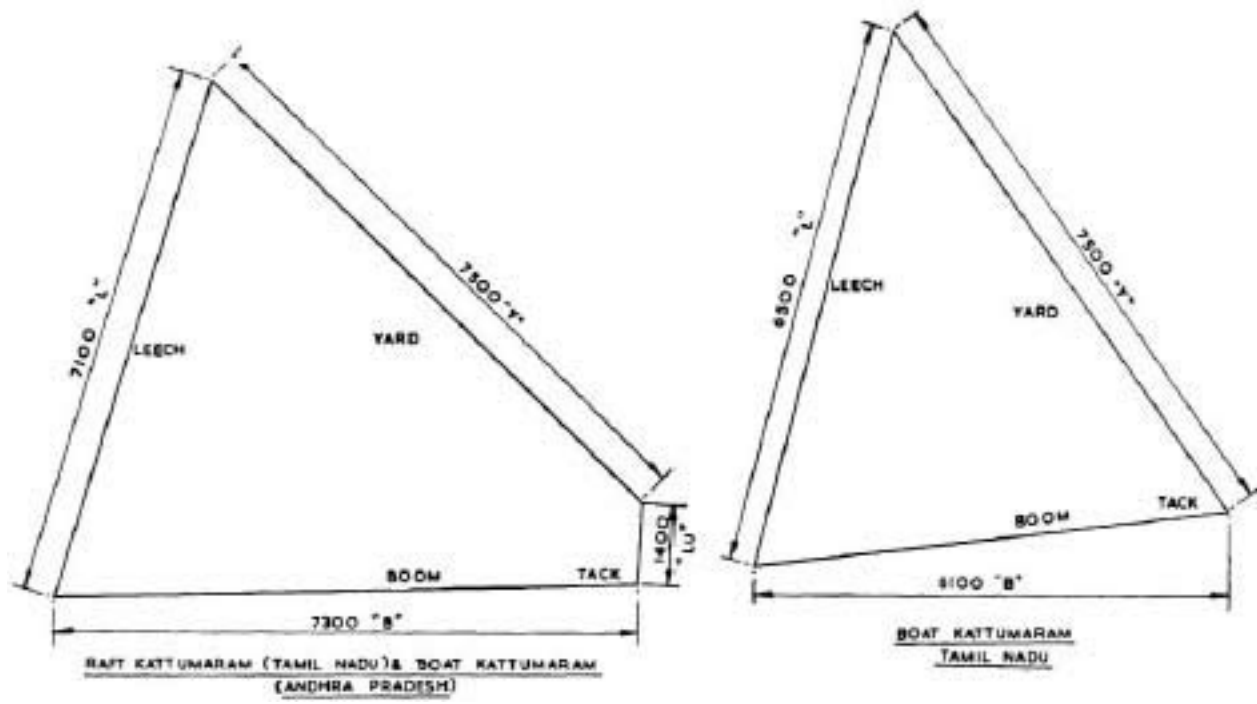

APPENDIX 7 : SAIL PLANS OF KATTUMARAMS