

Appendix 1

PROJECT LOCATION – POLEKURRU ISLAND
IN E. GODAVARI DISTRICT, ANDHRA PRADESH

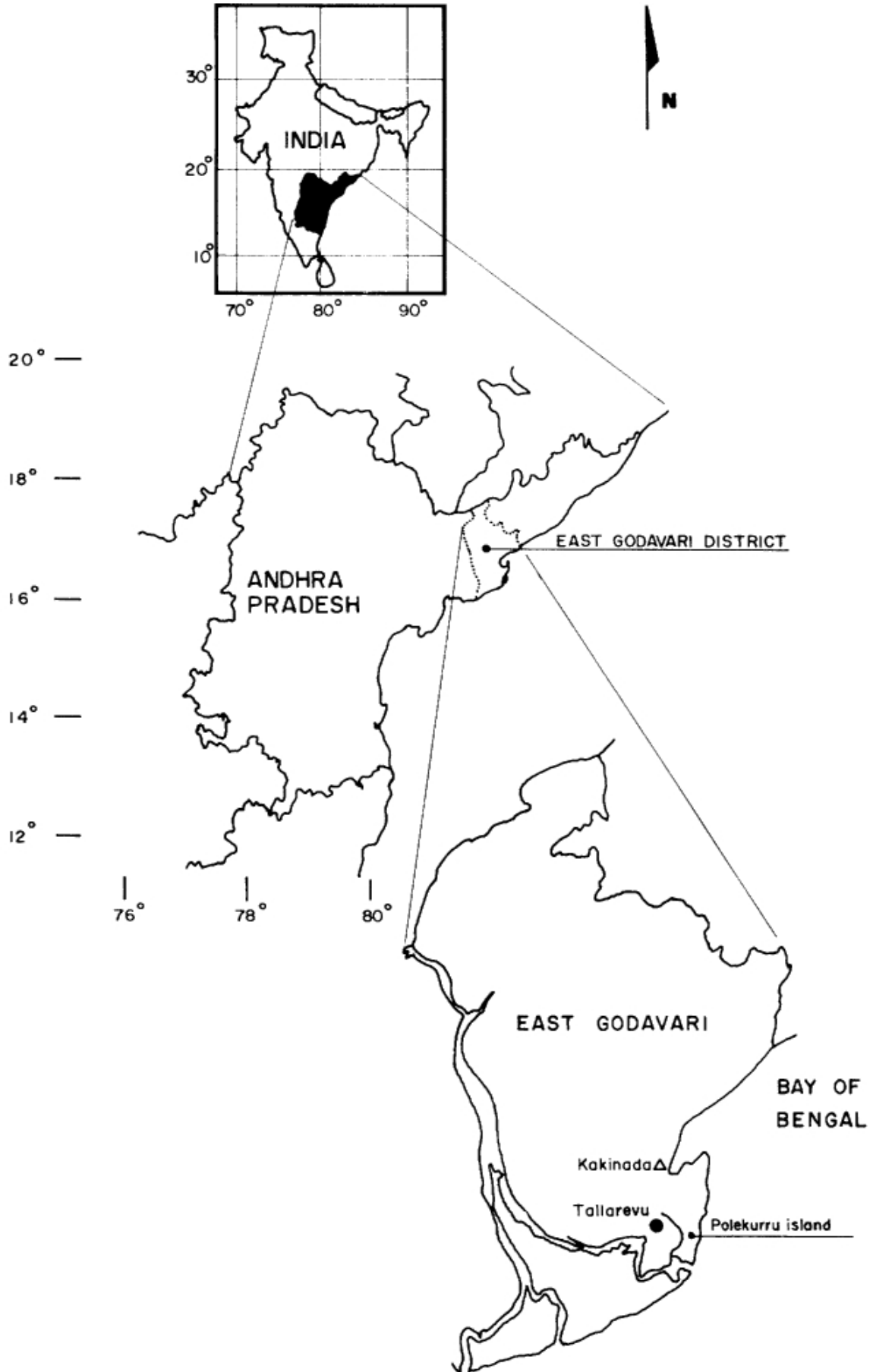

Appendix 2

SEQUENCE OF PROJECT ACTIVITIES: MAY 1980 TO SEPTEMBER 1985.

May 1980	BOBP requested by the Directorate of Fisheries, Andhra Pradesh (DOF/AP) to assist in coastal aquaculture.
September	Survey by DOF/AP of area suitable for brackishwater culture.
February 1981	Indonesian TCDC mission identifies coastal aquaculture possibilities.
August	Report of Indonesian mission.
November	Pilot project prepared.
March 1982	Government Order to start the project.
April	Team leader appointed and posted at Kakinada.
August	All staff posted in Tallerevu. Design of farm complex completed.
November	Pond construction starts.
March 1983	Five ponds constructed. Study tour for engineer to West Bengal to observe sluice gate designs.
July	Sluice gates constructed
August	First stocking (Pond 2)
November	Construction of jetties and bridges. Study tour for team leader to BOBP pen culture project in Killai, Tamil Nadu.
January 1984	First harvest (Pond 2).
April	Construction of Pond 6.
May	Laboratory building constructed.
June	Trainees (24) from Fisheries Training Institute undergo training for seven days.
September	Siltation of 25-30 cm is noticed in the tide fed ponds.
June 1985	Ten-day training course for fishermen.
July	Scientific officers (9) and private entrepreneurs (2) undergo seven-day training course.
August	Study tour to West Bengal for two scientific officers (seven days) to observe pond culture.
September	BOBP support terminated.

SCHEDULE OF STOCKING (S) HARVEST (H) AND DESILTATION (D)
(August 1983 – September 1985)

Pond	83					84														
	A	S	O	N	D	J	J	F	M	A	JASONDJ		FMAMJ		JAS					
1		S								H	S				HS			HD		
2	S														H	S		HD		
3		S																HS	HD	
4			S															HS	HDS	H
5				S											H	S		HS	HS	H
6															S			HS	HS	H

Appendix 3

POND COMPLEX ON POLEKURRU ISLAND

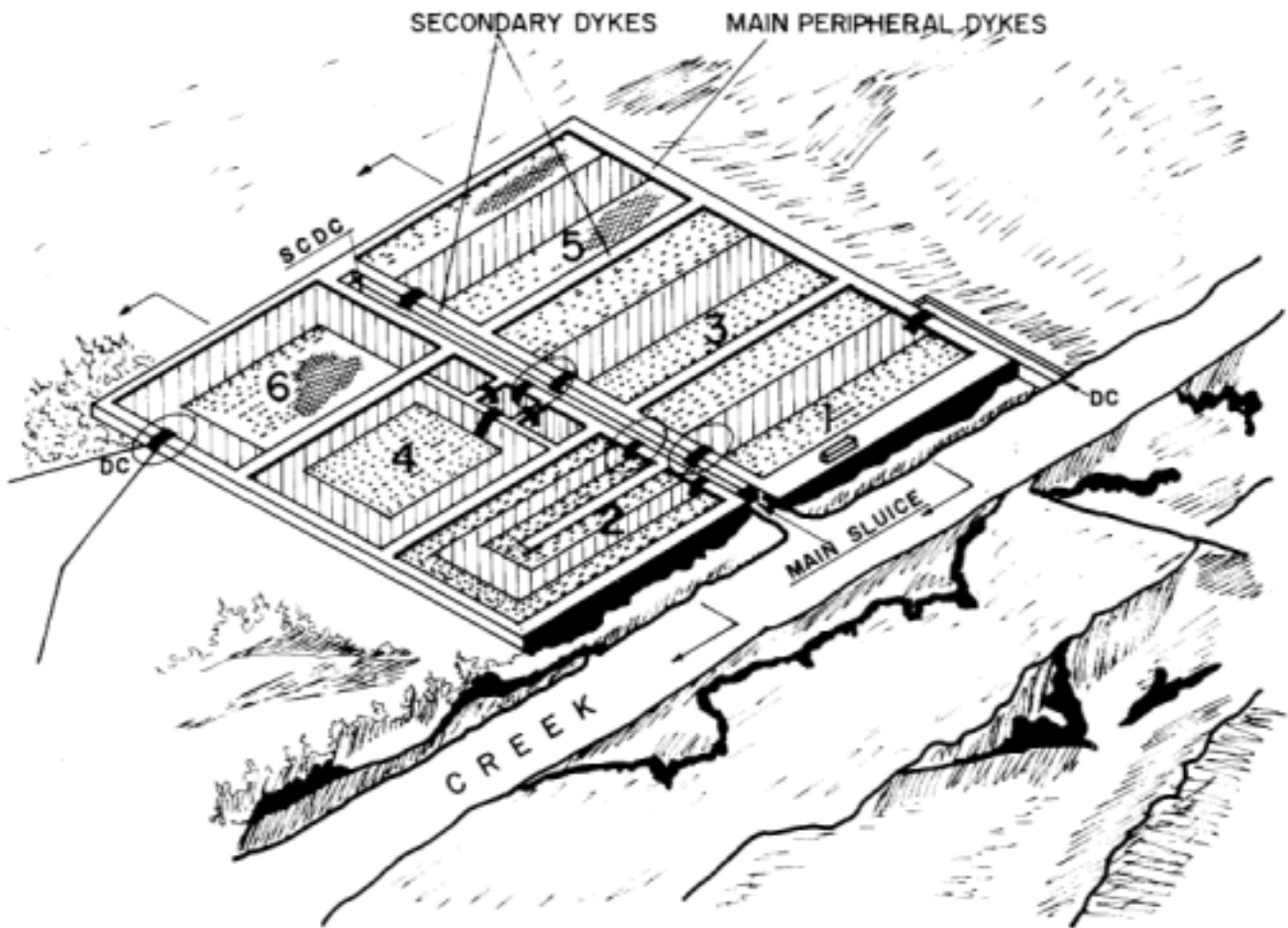

LEGEND



DYKE



DEEPEST PORTION (TRENCH)



SHALLOW PORTION (PLATFORM)



SHALLOW PORTION (PLATFORM)
ON GROUND LEVEL



LABORATORY



MASONRY SLUICE GATE



WOODEN SLUICE GATE



CROSS SECTION

SCDC = SUPPLY-CUM-DRAINAGE
CHANNEL

DC = DRAINAGE CHANNEL

Appendix 4

CROSS-SECTION OF PONDS 1-6

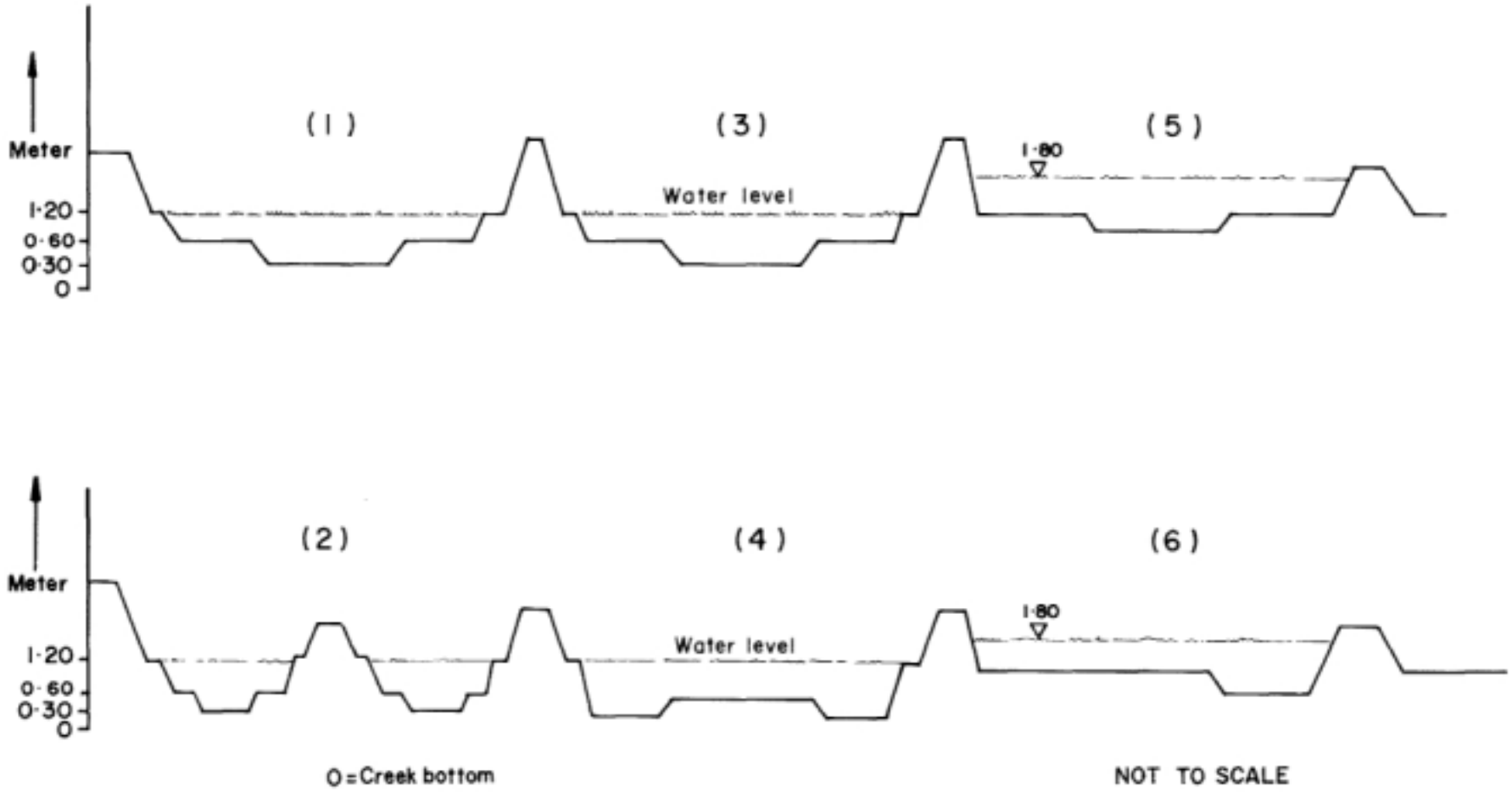

Appendix 5
DESIGN OF TWO-VENT MAIN SLUICE GATE

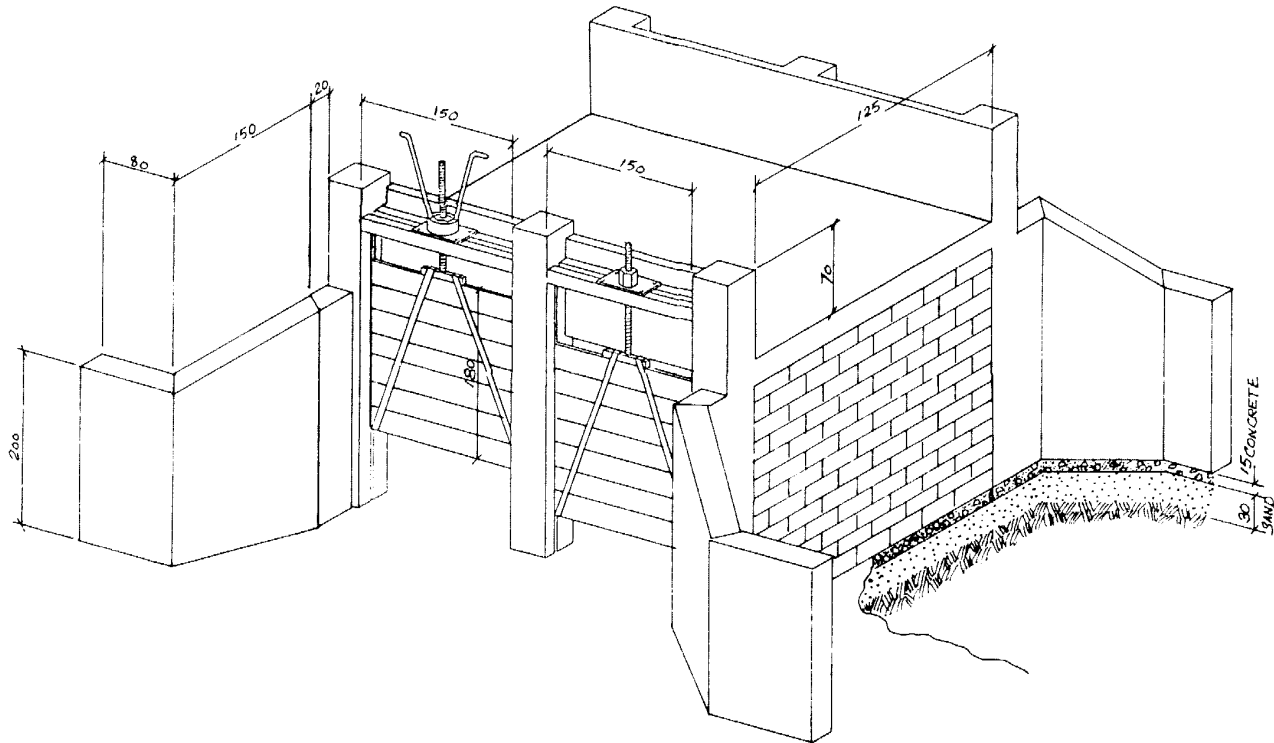

Appendix ~
SLUICE GATE DESIGN IN POND 6

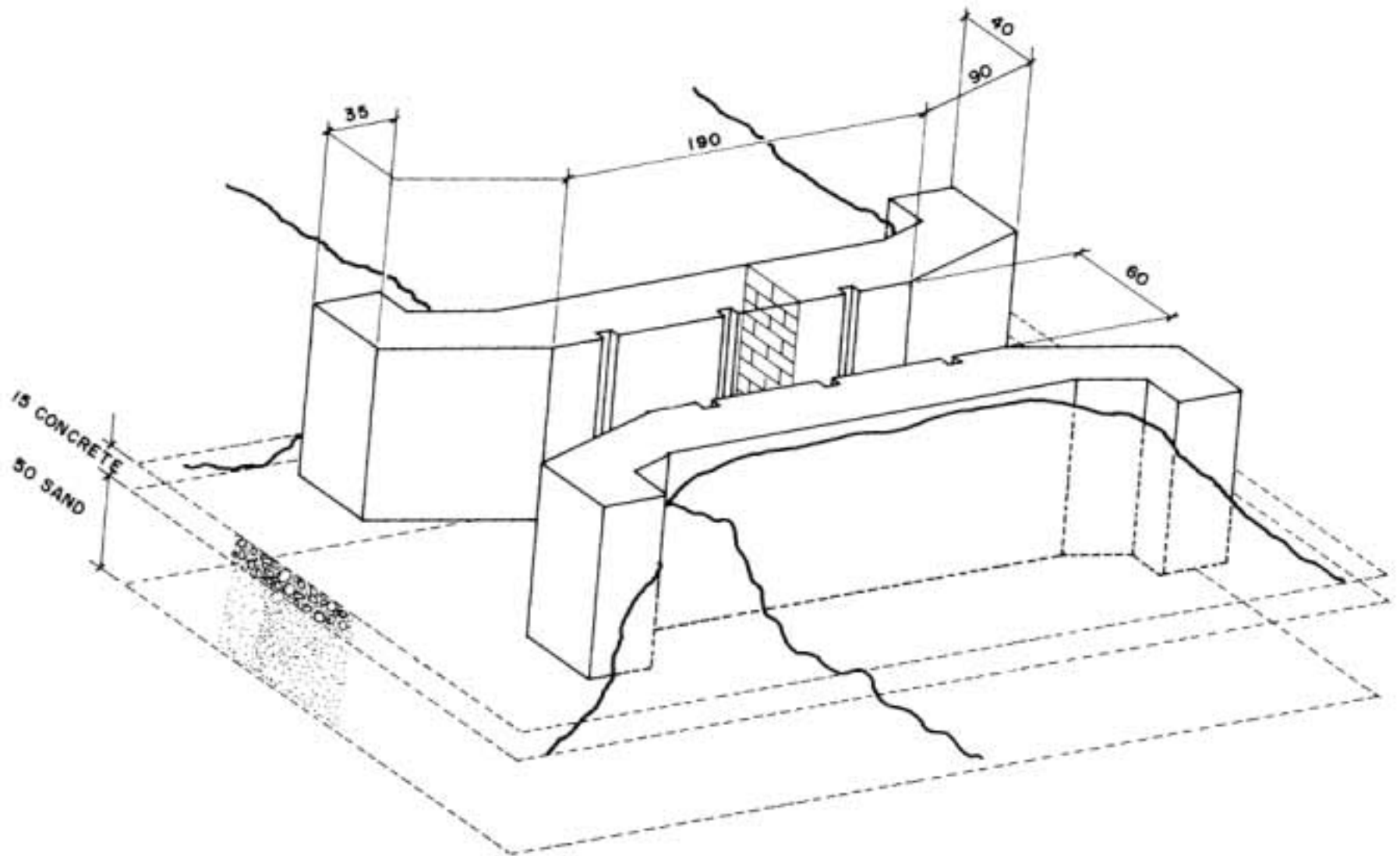

Appendix 7

ISOMETRIC VIEW OF WOODEN SLUICE GATE

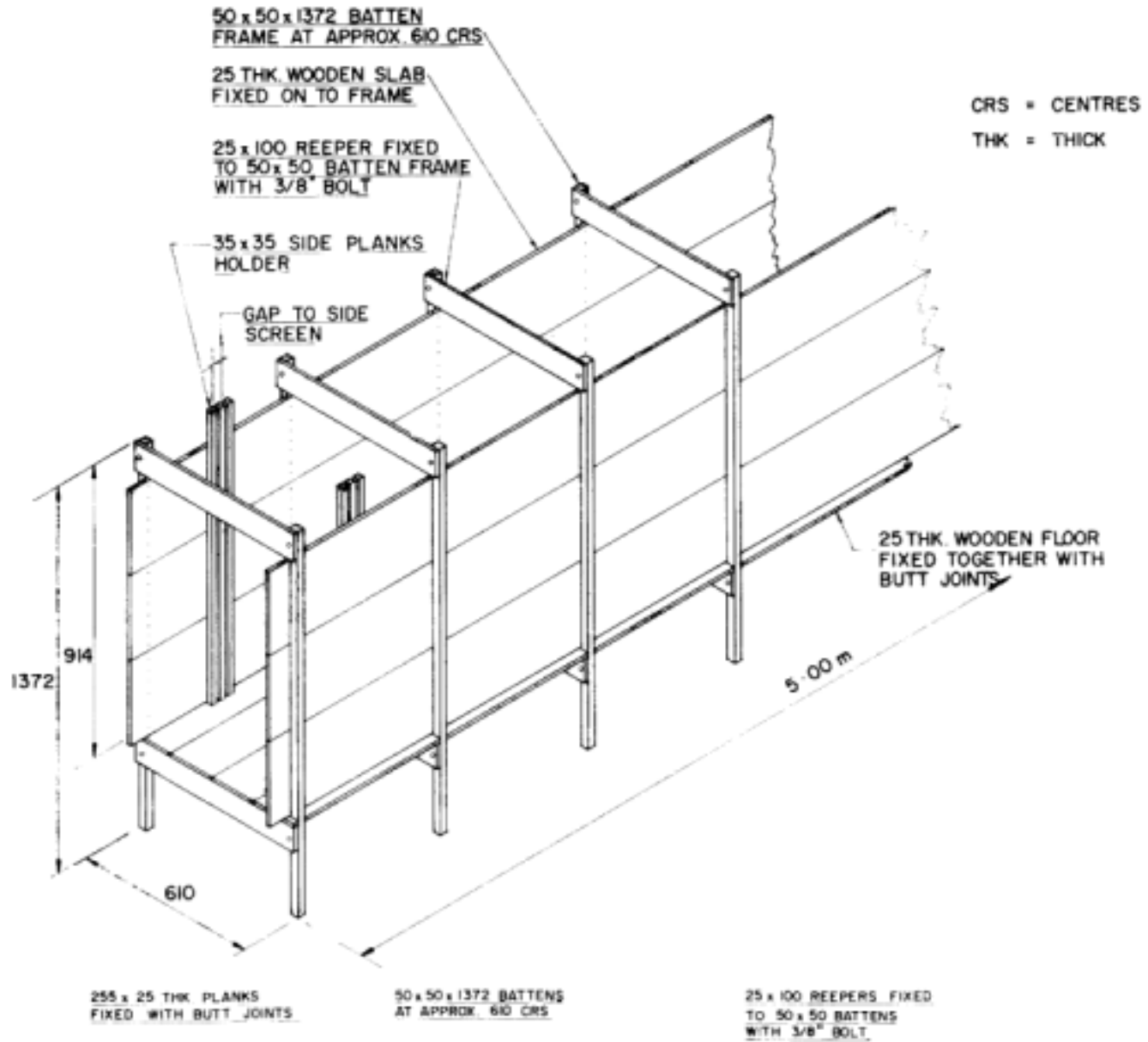

Appendix 8
CONSTRUCTION COSTS

Pond	1	2	3	4	5	6	Total
Excavation (m3)							
Pond	5,246	4,539	4,848	4,520	2,194	887	22,234
Drainage/nursery	210		—	91	—	210	511
Feeder canal	197	197	197	197	197	197	1,182
Cost rate (As/m3)	4.6	4.6	4.6	4.6	4.6	5.5	—
Costs (Rs)							
Land	1,100	1,100	1,100	1,100	1,100	1,100	6,600
Earthwork pond	24,133	20,880	22,302	20,786	10,092	4,879	103,072
feeder canal	907	907	907	907	907	907	5,442
drainage/nursery	1,142			423		1,142	2,707
Main sluice gate	6,980	6,980	6,980	6,980	6,980	6,980	41,880
Wood sluice gate	5,342	5,342	—	16,026	5,342	—	32,052
Masonry sluice gate	8,948	8,948	8,948	8,948		3,000	38,792
Pumpset (1)	—		..	.	1,500	7,500	15,000
Jetty, bridges	833	833	833	833	833	835	5,000
Lab building	—					—	66,349
Total cost (Rs)	49,385	44,990	41,070	56,003	32,754	26,343	316,894

Approximate exchange rate: US \$ 1 Rs 12.5ft

Appendix 9a

RESULTS OF FIRST HARVEST

TABLE	POND 1	POND 2	POND 3	POND 4	POND 5	POND 6
Water spread (ha)	0.75	0.70	0.75	0.60	0.75	
Species	Pi, Pm	Pm	Pm	Pm	Pi	
Stocking (nos)	51,555	22,600	25,150	24,807	51,427	
(per ha)	68,740	32,285	33,533	41,345	68,569	
Average stocking weight (g)	0.1	1.2	1.2	0.1	0.1	
Weight range (g)	.05-15	.3-12.0	.1-1.8	.05-10	.05-10	
Culture period	30.9.83	26.8.03	5.9.83	15.10.83	4.11 83	
	17.4.84	24.1.84	17.2.84	21.3.84	20.5.84	
Duration (Days)	200	151	164	157	196	
Feed supplied (kg)	1,967	1 986	2,086	1 894	1,752	
Production (kg)						
<i>P. monodon</i>	47.8	265.3	213.0	170.0	1.7	
<i>P. indicus</i>	89.7	—	—	—	105.0	
Miscellaneous shrimp	24.8	32.1	72.0	24.0	3.3	
Fish	38.5	11.1	18.6	1.7	76.4	
Total	2008	308.5	303.6	195.7	186A	
Pm + Pi (kg/ha)	170	378	284	284	143	
Total production (kg/ha)	268	441	405	326	249	
Survival — Pm + Pi (%)	35	72	54	44	25	
Average harvest weight (g)	7.5	16.0	15.6	15.6	6.5	
Weight range (g)	2.0-18.5	6-55	8-32	8-32	3-10	
Feed/net production	10.1	6.5	6.9	9.8	97	

Appendix-9b

RESULTS OF SECOND HARVEST

TABLE	POND 1	POND 2	POND 3	POND 4	POND 5	POND 6
Water spread (ha)	0.75	0.70	0.75	0.60	0.75	0.60
Species	Pi, Pm	Pi, Pm	Pi, Pm	Pm	Pm	Pm
Stocking (nos)	22,500	21,015	22,420	15,000	22,500	10,700
(per ha)	30,000	30,021	29,893	25,000	30,000	17,833
Average stocking weight (g)	1.0	0.2	0.5	0.5	0.07	4.1
Weight range (g)	.1-2.0	.1-2.0	.05-0.60	.05-0.60	.05-1.0	.1-6.0
Culture period	26.6.84	11.2.84	10.3.84	10.4.84	15.7.84	12.5.84
	12.12.84	14.8.84	6.10.84	6.9.84	23.11.84	13.8.84
Duration (days)	168	184	208	170	130	92
Feed Supplied (kg)	930	1237	936	828	573	819
Production (kg)						
<i>P. monodon</i>	96.7	184.8	136.7	172.2	93.9	147.6
<i>P. indicus</i>	45.7	43.3	24.6	10.8	19.4	16.5
Miscellaneous Shrimp	8.3	54.5	123.5	7.0	16.0	6.5
Fish	64.0	20.0	30.5	11.0	71.0	10.0
Total production	214.7	302.6	315.3	201.0	200.3	180.6
Pm + Pi (kg/ha)	190	325	215	305	151	273
Total production (kg/ha)	285	423	420	335	268	301
Survival — Pm + Pi (%)	59	82	58	68	47	85
Average harvest weight (g)	9.8	12.9	12.5	16.6	10.7	17.9
Weight range (g)	4.0-30.0	7.3-24.5	5.5-27.9	7.5-30.0	4.0-49.5	9.4-31.3
Feed/net production	4.9	4.1	3.1	4.3	2.9	6.0

Appendix 9c

RESULTS OF THIRD HARVEST

TABLE	POND 1	POND 2	POND 3	POND 4	POND 5	POND 6
Water spread (ha)	0.75	0.70	0.75	0.60	0.75	0.60
Species	Pi	Pm	Pm	Pm	Pm	Pi, Pm
Stocking (nos)	50,000	21,000	22,500	18,000	15,000	18,000
(per ha)	66,700	30,000	30,000	30,000	20,000	30,000
Average stocking weight (g)	0.14	0.5	1.0	0.5	5.0	0.5
Weight range (g)	.05-1.12	.1-3.0	.1-2.0	.05-3.0	.1-9.5	.02-2.0
Culture period	18.1.85 21.6.85	6.10.84 2.3.85	27.10.84 20.4.85	23.10.84 18.4.85	24.12.84 3.4.85	7.9.84 13.2.85
Duration (days)	130	146	173	175	97	158
Feed supplied (kg)	1158	766	1073	1055	1039	1324
Production (kg)						
<i>P. monodon</i>	6.0	206.3	60.6	48.8	223.6	120.0
<i>P. indicus</i>	189.7	6.0	—	5.7	0.9	80.2
Miscellaneous shrimp	4.0	155.0	109.0	24.6	1.8	28.2
Fish	0.3	7.0	5.5	14.0	21.0	5.4
Total production	200.0	374.3	175.1	93.1	247.3	233.8
Pm + Pi (kg/ha)	261	302	81	90	300	333
Total production (kg/ba)	268	535	234	155	330	381
Survival (Pm + Pi) %	48	65	32	37	99	61
Average harvest weight (g)	8.0	15.6	8.9	11.6	15.0	18.0
Weight range (g)	7.2-9.0	6-36	8.0-37.7	5-26	4-31	5-43
Feed/net production	6.0	2.1	7.0	12.5	6.0	5.9

Appendix 9d

RESULTS OF FOURTH HARVEST

TABLE	POND 1	POND 2	POND 3	POND 4	POND 5	POND 6
Water spread (ha)				0.60	0.75	0.60
Species				Pm	Pm	Pm
Stocking (nos)		Under culture		21,789	18,361	12,980
(per ha)				36,315	24,481	21,633
Average weight (g)		September 1985		8.0	4.8	2.0
Weight range (g)				6.0-8.5	2.5-8.0	0.5-3.5
Culture period				21.6.85	30.4.85	20.3.85
				22.8.85	31.8.85	26.6.85
Duration (days)				60	120	98
Feed supplied (kg)				719.5	1520	849
Production (kg)						
<i>P. monodon</i>					236.5	1660
<i>P. indicus</i>				156.0	2.0	26.2
Miscellaneous shrimp				20.0	8.0	11.4
Fish				- +	- +	2.4
Total production				176.0	246.5	206.0
Pm + Pi (kg/ha)				260	318	320
Total production (kg/ha)				293	329	343
Survival (Pm + Pi) %				64	65	88
Average harvest weight (g)				11.0	20.0	17.0
Weight range (g)				10-13	16-26	145-35
Feed/net production				423	9.6	4.4

Appendix 10

CATCH OF *P. INDICUS* AND *P. MONODON* BY PUSH NET

WITH WOODEN FRAME AND BY HAND NET BY ONE MAN IN HALF AN HOUR

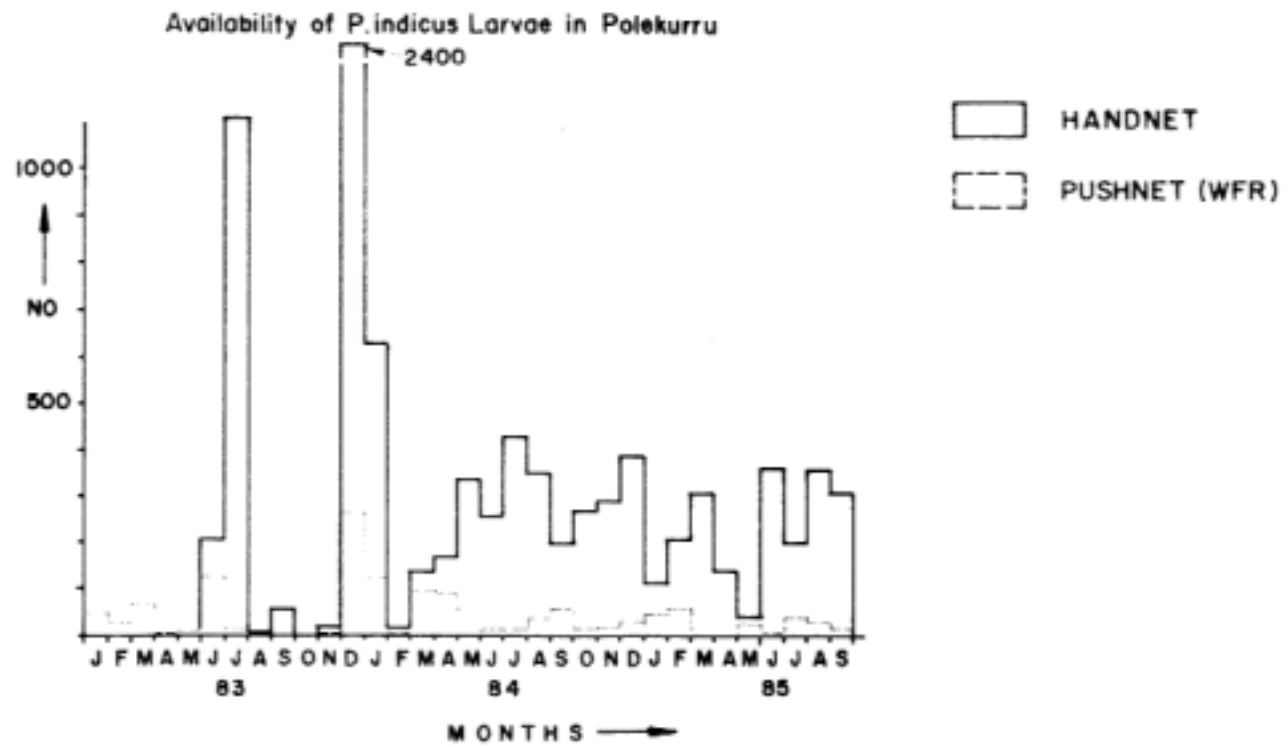
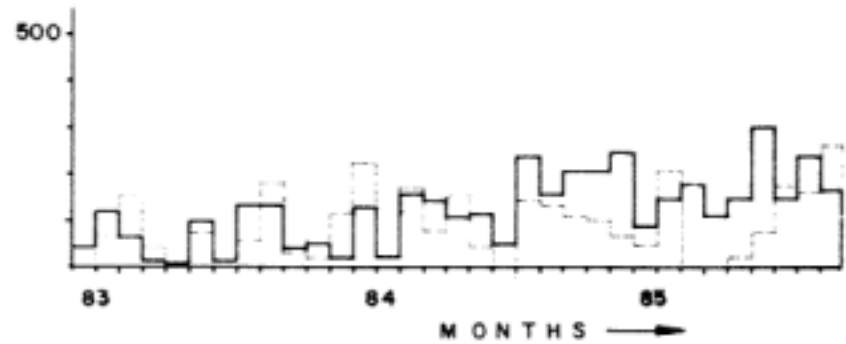

Availability of *P. monodon* Larvae in Polekurru

Appendix 11

DAILY TIDE LEVEL RECORDINGS IN
VADALANALI CREEK, MAY 1983 – APRIL 1984

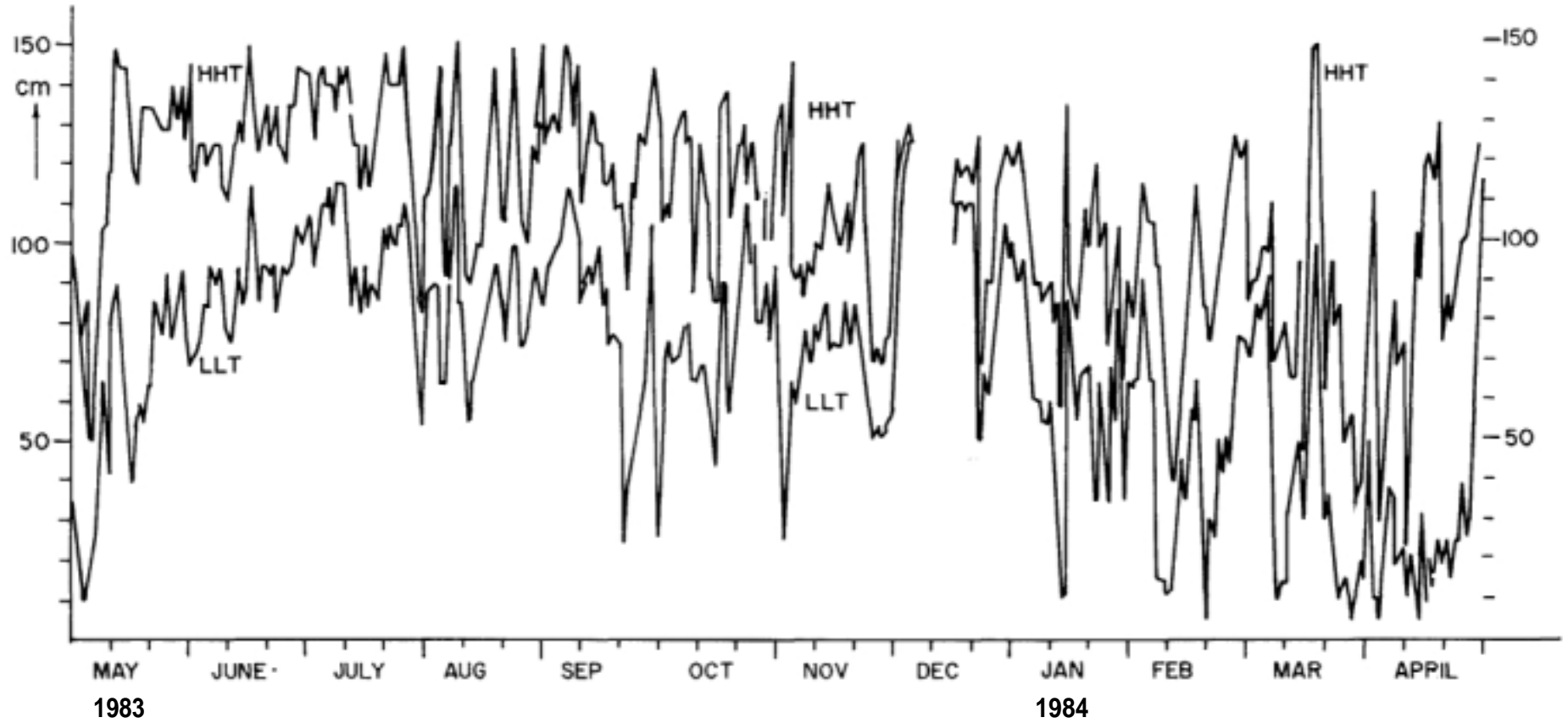

HHT- Highest high tide
LLT - Lowest low tide

Appendix 12

TIDE LEVELS AND WATER MANAGEMENT SCHEDULE
FOR TIDE AND PUMP-FED PONDS, NOVEMBER 1983

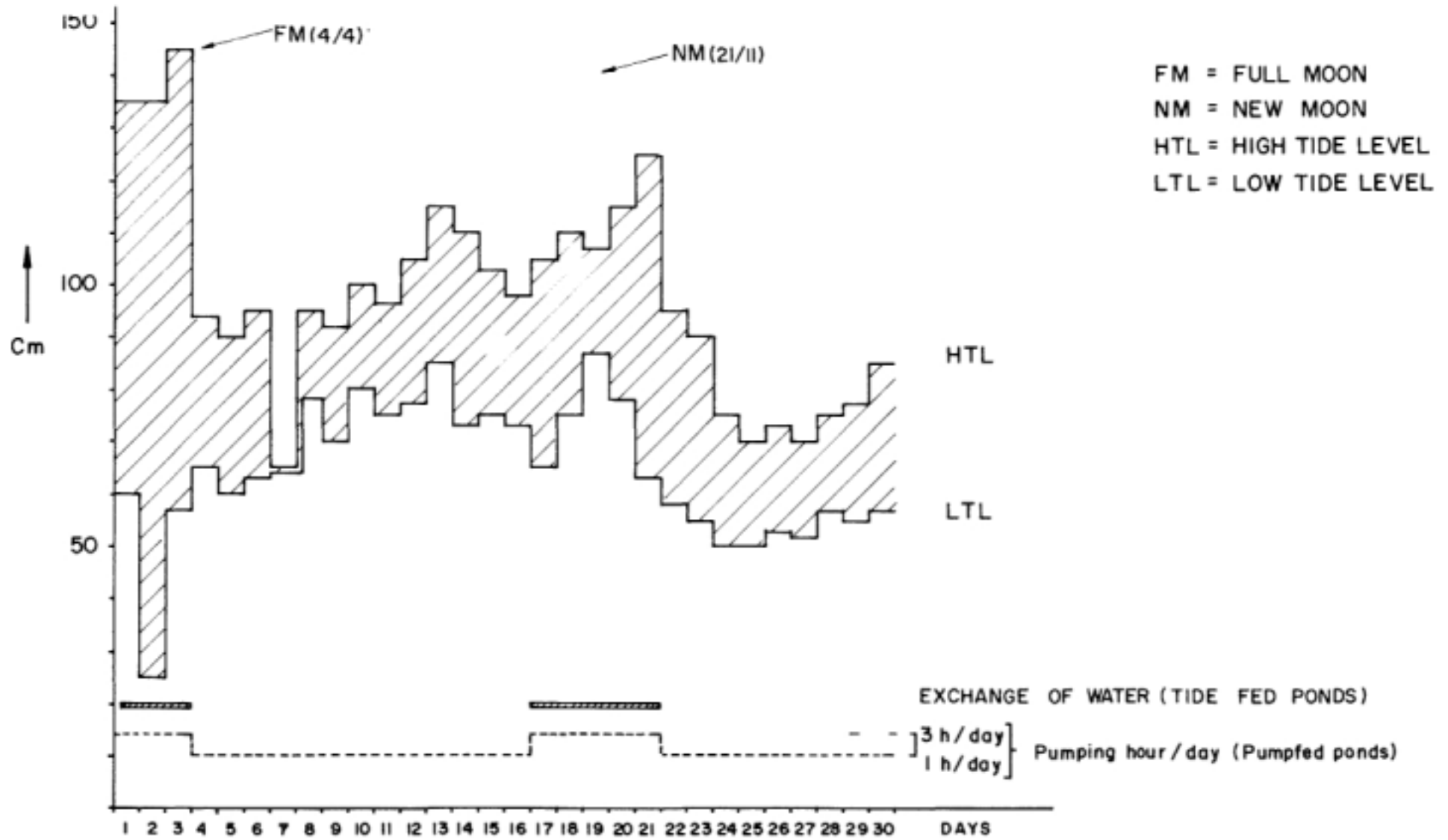

Appendix 13

DAILY SALINITY AND TEMPERATURE RECORDINGS

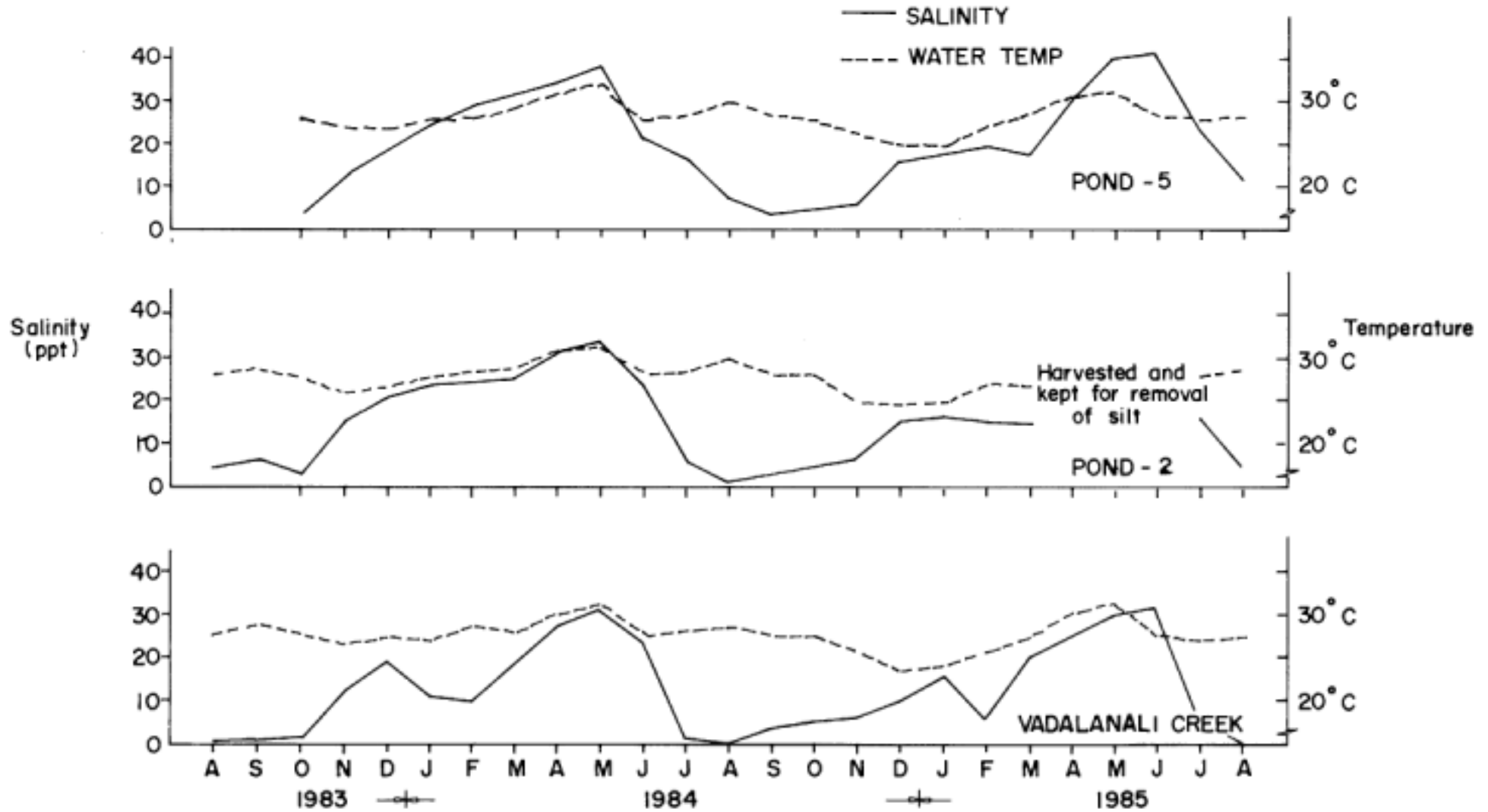

Appendix 14

EXPENDITURES AND SALE PROCEEDS (IN RUPEES)

PARTICULARS	POND 1	POND 2	POND 3	POND 4	POND 5	POND 6	TOTAL
<i>1st Cycle</i>							
Feed	3146	2422	2919	2671	2803		13961
Fertilizer	571	571	571	571	571		2855
Seed	1750	1130	2200	750	1750		7580
Fuel	—	—	—	—	520		520
Labour	1290	974	1058	1013	1267		5602
Total Cost	6757	5097	6748	5005	6911		30518
Sales	2249	9098	7761	6092	1924		27124
Return	(4508)	4001	1013	1037	(4987)		(3394)
<i>2nd Cycle</i>							
Feed	1490	1692	1427	1240	902	1098	7849
Fertilizer	557	631	673	444	480	281	3066
Seed	792	735	795	525	863	275	3985
Fuel	—	—	—	—	660	500	1160
Labour	1124	1232	1402	1157	879	663	6457
Total Cost	3963	4290	4297	3366	3784	2817	22517
Sales	1566	5093	3261	4418	2332	6325	22995
Return	(2397)	803	(1036)	1052	(1452)	3508	478
<i>3rd Cycle</i>							
Feed	1120	999	1344	1314	1215	1835	7827
Fertilizer	327	303	415	355	365	384	2149
Seed	750	788	788	630	525	630	4111
Fuel	—	—	—	—	408	878	1286
Labour	909	1062	1176	1189	716	1079	6131
Total Cost	3106	3152	3723	3488	3229	4806	21504
Sales	472	5470	1468	866	8478	6657	23411
Return	(2634)	2318	(2255)	(2622)	5249	1851	1907
<i>4th Cycle</i>							
Feed				1225	2234	1192	4651
Fertilizer				86	50	75	211
Seed		under culture in September 1985		*	*	454	454
Fuel				—	589	627	1216
Labour				567	909	722	2198
Total Cost				1878	3782	3070	8730
Sales				4670	9322	4635	18627
Return				2792	5540	1565	9897
TOTAL							
Feed	5756	5113	5690	6450	7154	4125	34288
Fertilizer	1455	1505	1659	1456	1466	740	8281
Seed	3292	2653	3783	1905	3138	1359	16130
Fuel	—	—	—	—	2177	2005	4182
Labour	3323	3268	3636	3926	3771	2464	20388
Total Cost	13826	12539	14768	13737	17706	10693	83269
Sales	4287	19661	12490	16046	22056	17617	92157
Return	(9539)	7122	(2278)	2309	4350	6924	8888

- (From other ponds)