

Bay of Bengal Programme

Small-Scale Fisherfolk Communities

SILVI-PISCICULTURE PROJECT IN SUNDERBANS
WEST BENGAL:
A SUMMARY REPORT OF BOBP'S ASSISTANCE

BOBP/WP/62



BAY OF BENGAL PROGRAMME
Small-Scale Fisherfolk Communities

BOBP/WP/62
GCP/RAS/1 18/MUL

**SILVIPISCICULTURE PROJECT IN SUNDERBANS. WEST BENGAL:
A SUMMARY REPORT OF BOBP'S ASSISTANCE**

by Charles L Angel!
Senior Aquaculturist, BOBP
and James Muir
Aquaculture Engineer, FAO (Consultant)

Executing Agency
Food and Agriculture Organization
of the United Nations

Funding Agencies
– Danish International
Development Agency
– Swedish International
Development Authority

Bay of Bengal Programme For Fisheries Development.
Madras, India, September 1990
Mailing Address : Post Bag No. 1054, Madras 600 018, India.
Street Address : 91, St. Mary's Road, Abhiramapuram, Madras 600 018, India
Cable : FOODAGRI Telex 41-8311 BOBP Fax 044-836102
Phones : 836294, 836096, 836188, 836387, 836179

This paper summarizes technical assistance provided by the BOBP to a silvi-pisciculture project in the Sunderbans, West Bengal. The project was implemented by the forest department of the West Bengal Government, and funded by SIDA (Swedish International Development Authority) between 1983 and 1988.

BOBP assistance was provided in the form of four consultancy assignments between end-1986 and early 1988, and related to the pisciculture aspect of the project. Specifically, it concerned advice on the development of high-yielding aquaculture techniques, and the construction of appropriate cost-effective sluice designs; and a social feasibility study to stimulate people's participation in the project.

The Bay of Bengal Programme aims at developing, demonstrating and promoting technologies and methodologies to improve the conditions of small-scale fisherfolk communities in seven member-countries—Bangladesh, India, Indonesia, Maldives, Sri Lanka, Thailand. Assistance to the silvi-pisciculture project was provided by the BOBP's main project, which was funded by SIDA in its first phase (1979-1986) and is being funded jointly by DANIDA and SIDA during its second phase, which began 1987.

This document is working paper and has not been officially cleared by the Governments concerned or by the FAO.

CONTENTS

	<i>page</i>
1. Introduction	
2. BOBP's inputs	2
3. Controlled stocking	20
4. Research	22
5. Environmental monitoring	22
6. Equipment requirements	22
7. People's participation	23
8. Conclusions and recommendations	24

Tables

1. Sluice and dike designs : characteristics and problems	2
2. Main criteria for sluice gates	3
3. Typical physico-chemical data, Sundarban soils	3
4. Brackishwater tidal exchange volumes (1000 m ³)	5
5. Brackishwater tidal exchange volumes, average flow rate m ³ /Hr	5
6. Relative tidal levels, Sagar Tidal Observatory station, West Bengal	6
7. Calculation of rainfall runoff	9
8. Comparative costs of sluices : effects of lifespan or period of use	10
9. Settling areas required for silt removal	II
10. Sluice design options	19
11. Water management	20

Figures

1. Typical dike cross sections and relative water levels	4
2.(a) Relationship between changes in interior water levels for any given tidal difference and standard pipe sizes for 10 ha and 5 ha water areas	7
(b) Relationship between changes in interior water levels for any given tidal difference and standard pipe size for 2 ha and 1 ha water areas	8
3. Alternative sluice designs :	12
(a) Exterior sluice : general layouts/sections	12
(b) Main sluice details	13
(c) Main sluice details	14
(d) Main sluice details	15
(e) Interior sluices	16
4. Methods for protecting sluice gate sites	17
5. Erosion protection devices	18
(a) Overflows, barmes	18
(b) Dike reinforcement	18
6. Establishing local site and tidal levels	21

Appendices

1. Background information used in design calculations	26
2. Cost outline – sluices	30
3. Cost outline – protective works	32
4. Cost outline – silvipisciculture project	33

<i>Publications of the Bay of Bengal Programme</i>	34
--	----

1.0 Introduction

The mangrove ecosystem fringing subtropical and tropical coastlines plays a crucial role in maintaining the stability of the adjacent aquatic ecosystem. They were long regarded in some quarters as “wastelands,” but research during the past 40 years has highlighted the importance of mangroves in several important aspects

- preventing erosion
- providing an indispensable input of organic carbon into the aquatic ecosystem and hence generating food and shelter for myriads of commercially important fish and crustacean larvae and juveniles
- providing a sustainable source of wood and wood products
- serving as an essential habitat for a variety of wildlife.

Yet, the pressure of ever-increasing coastal concentrations of humans has led to the destruction of large areas of mangrove forests through deforestation, dredging and land filling. During the past decade, the development of shrimp farms has led to extensive clearing of mangroves.

Severely disturbed mangrove forests as well as newly accreted lands offer opportunities for combining aquaculture and forestry development in a system compatible with mangrove restoration. This approach has been dubbed silvipisciculture. It is not a new concept, as one can observe the traditional integration of mangrove afforestation with brackishwater fish ponds in the tambak systems of central and east Java, Indonesia.

Under an agreement between the Governments of India and Sweden, the Swedish International Development Authority (SIDA) undertook a silvipisciculture (SPC) project in Sunderbans, West Bengal, from July 1983 to June 1988. The project was implemented through the Forest Department (FRD) of the Government of West Bengal (GOWB); some 70% of the estimated project cost of Rs.9.2 million was SIDA's contribution.

The work on SPC is one of the two main components of the project on intensified land use in West Bengal; the other component is agro-silvipisciculture in the northern part of West Bengal.

The concept of SPC is based on two principles – the role of detritus, derived mainly from mangrove leaf fall, in augmenting fish production and an ecologically balanced development of disturbed tidelands. The disturbances may result from deforestation, intrusion of seawater into coastal farmlands or diversion of freshwater from an estuary.

About 640 sq km of the mangrove area of the Sunderbans consists of denuded or poor-vegetation land, a result of natural or biotic disturbances. Since afforestation is prohibitively expensive and monoculture of prawns might destroy the environment, a combination of forestry and fish culture is considered the best technology, in as much as it ensures multiple land use and generates jobs and incomes for the local population. Theoretically, SPC is ecologically balanced, technically feasible, economically sustainable and hence sociologically tuned for acceptance.

Conceptually, the SPC system involves the construction of perimeter dikes and interior ridges with soil obtained from inside the dikes, creating a series of ponds, trenches and channels for fish and shrimp culture, interspersed with intermediate level mangrove stands and raised tree crop beds. Water exchange and level control is provided by a combination of main sluices in the perimeter dikes and simple internal sluices within the enclosed area.

It was originally intended to bring under SPC an area of 1000 ha - 25 complexes of 40 ha each with a water area of 10 ha in each complex. However, for various reasons, the construction programme stopped with 9 complexes at 3 sites, Bhagabatpur, Sabtamukhi and Dhanchi. Each complex had its own peculiarities as a result of differences in land elevation, soil salinity and vegetative cover; hence there were differences in the layout of each complex.

After 3½ years of activity when a mid-term review was undertaken, it was seen that the silviculture aspect of the project had made good progress, but on the pisciculture side, the production was

low, ranging from 52 kg/ha to 198 kg/ha for a 9-month culture period (only at Bhagabatpur had pisciculture then been attempted). It was therefore decided to focus attention on the development of high-yielding sustainable aquaculture techniques and production which would require, as a precursor, appropriate sluice designs; and also to have a social feasibility study undertaken to find ways and means to involve the local people in an effective way. It was for fulfilling these needs, at the request of SIDA in 1986, that the Bay of Bengal Programme (BOBP) provided technical assistance on a consultancy basis from time to time.

Four consultancy assignments were arranged between end-1986 and early 1988.

- A. Participation of BOBP's Senior Aquaculturist, Mr C L Angell, in the SWEDFOREST/SIDA Mid-term Review Mission mentioned above, to advise on methods for improving aquaculture production in the SPC units (24.11.1986 to 4.12.1986). The first two of the following activities were a sequel to the recommendations of the mission.
- B. Assignment of an Aquaculture Engineer from FAO, Rome (Mr J F Muir) to provide suitable and cost-effective sluice designs and to identify appropriate guidelines for water management associated with the operation of sluices (24.5.1987 to 3.6.1987).
- C. Conduct of a socio-economic study around the SPC units by Ms M Mukhopadhyay, a National Consultant, to identify indigenous mechanisms for involving people's participation (PEP) in SPC activities (November-December 1987).
- D. Participation of BOBP's Senior Aquaculturist in the SWEDFOREST/SIDA evaluation mission to assess the outcome of the project and make recommendations for the future (February - March 1988).

Thus it would be seen that BOBP's inputs happened to flow in at a very advanced stage of the project - when it was nearly 3½ years old - and extended in intermittent spells till the end of the project.

This document summarizes the major issues and recommendations emerging from the consultancies mentioned above for the benefit of follow-up activity.

2. BOBP'S INPUTS

Improvement of the pisciculture component of the SPC system is based on two aspects - water management and controlled stocking.

2.1. Water Management

2.1.1 Sluice Gates : Aquaculture management as practised at the project site was rudimentary; simple cut-and-fill trenches, cut through the dikes, were often employed instead of conventional water supply sluices. They have often failed or have been found inadequate to supply the exchange of water likely to be necessary. In addition, the levels of different sites varied widely, and little data was available on relative tidal changes.

The main features of the existing sluice and dike designs and their methods of construction are given in Table I. It may be seen that there were considerable problems both with the sluices and with the dikes.

Table I

Sluice and dike designs : characteristics and problems

Sluices	<p>Exterior sluices; small diameter (0.3m) hume pipes, cut and fill trenches.</p> <p>Interior sluices; hume pipes, trenches and simple bamboo screens, wooden boxes.</p> <p>No reinforcement of piling is used, there are problems with seepage, and settling.</p> <p>Wall protection is sometimes used, but frequent erosion and scouring problems occur.</p> <p>There are no specific anti-seepage measures used for the sluices themselves.</p> <p>There are problems with settlement and separation/breakage of hume pipes.</p> <p>Water flow control is difficult and imprecise. 'Piping' and 'washouts' cause problems, particularly with poor water control.</p> <p>Many sluices are not set at a suitable level to exchange water efficiently.</p>
---------	--

Dikes Exterior dikes; approx. 1.5 m crown, 2 m height, 1:1 to 1:1.5 slopes, simply constructed from nearby borrow pits or channels.

Interior dikes; either planted ridges or small walls, 0.3 m crown, 1-1.5 m height vertical slopes, often temporary or regularly maintained.

There are considerable amounts of topsoil and root material in exterior dikes.

Many of the dikes are badly cracked, even after only 12-24 months, and will not work effectively. There are no 'cutoff' or 'puddle' trenches used, particularly across creek beds. They are not generally compacted, are variable in profile, and are often eroded. There are considerable problems with burrowing crabs.

One of the particular problems of the area is that there are in effect two tidal regimes. The wet season tides are 0.5 or 1.0 m higher than the dry season tides (Fig-I); the sluices must therefore be considerably more flexible in use and more robust to withstand the extremes of flood conditions.

An outline of the main criteria for exterior and interior sluice gates is given in Table 2. Both types should be basically cheap, effective and easily used and maintained.

Table 2
Main criteria for sluice gates

EXTERIOR GATES	INTERIOR GATES
Good seepage control	Moderate to good seepage control
Able to handle a wide range of flow and level conditions	Able to operate over a moderate level range
Able to exchange a range of internal water volumes; typically 10-30%/day	Easily movable, or easily dismantled. Exchange 10-30% of pond or trench/day
Lifespan at least 5 years; up to 20+	Lifespan 1-5 years
Typically serves 10 ha	Typically serves 1, 2, 5 ha
Set in crown width of approx. 1.5 m	Set in crown width of 0.3 - 0.5 m
Primary point of predator control	Secondary point of predator control
Good scour protection	May double as harvesting trap
Silt control may beneeded.*	Silt control possible

- *Note:* The lifespan of the gates and the need for silt control depends on whether the management policy will be to allow the pond areas to silt up, thereby restoring the whole area to terrestrial production or to maintain ponds for longer-term income from aquaculture. The design implications are discussed elsewhere.

Table 3
Typical physico-chemical data, Sundarban soils

Location		Moisture %	pH 1:2:5	Sand (%)	Silt (%)	Clay (%)
Bakkhali	1	26.7	8.2	32	40	28
	2	23.6	7.8	18	44	38
Basanti	1	27.9	8.2	29	35	35
	2	18.3	7.9	19	34	36
Sajnekhali	1	24.3	7.1	37	44	19
	2	16.9	6.6	48	28	24

Figure 1 : Typical dyke cross-sections and relative water levels

a Exterior dike

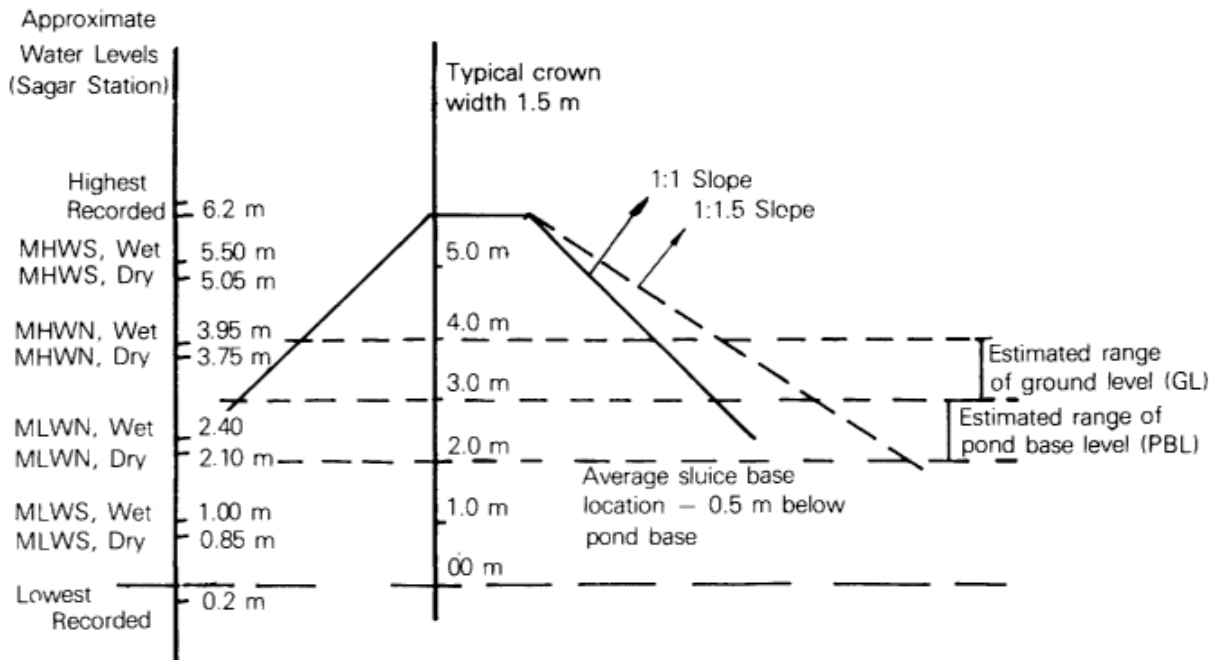

b : Interior dike

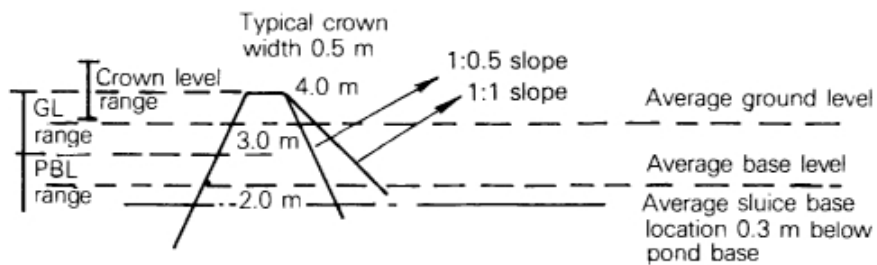

Source: Forestry Department, Government of West Bengal. Some background data (Table 3) on soil characteristics obtained during September-October 1986 (during and after heavy monsoon) correspond to silty-clay loam; the soil being relatively evenly graded and the clay content ranging from 19% to 38%. It provides good impermeability characteristics; but it has a relatively poor bearing capacity and shrinkage/cracking properties. It would be generally suitable for pond construction, though significant local variations, such as high clay content, acid soil, etc., might be expected.

2.1.2 Sizing the sluice

The sizing of sluice units depends both on the water exchange required, and on the tidal level characteristics. The typical water exchanges required through sluice gates for different circumstances are given in Tables 4 and 5. Table 6 provides the mean tidal levels during the wet and dry seasons and at neap and spring tides. The sluice design is based on the supposition (common in most forms of brackishwater aquaculture) that water will be exchanged during spring tide cycles only. However, as will be discussed later, there is little or no specific tidal data for individual sites; it will be necessary to obtain this if full benefit is to be gained from water exchange structures.

Table 4
Brackishwater tidal exchange volumes (1000 m³)

Note : Average pond depth (m) 1
 No of days in tidal cycle 5
 No of hours per filling tide 5

Area (ha)	Volume (ms)	Exchange required per tidal cycle (% volume)								
		10	20	30	40	50	60	100	200	300
1	1000	1	2	3	4	5	6	10	20	30
2	2000	2	4	6	8	10	12	20	40	60
5	5000	5	10	15	20	25	30	50	100	150
10	10000	10	20	30	40	50	60	100	200	300
20	20000	20	40	60	80	100	120	200	400	600

Table S
Brackishwater tidal exchange volumes, average flow rate m³/HR

Note : Average pond depth (m) 1 No of days in tidal cycle 5
 No of hours per filling tide 5 No of filling tides used/day 1

Area (ha)	Vol (mi)	Exchange required per tidal cycle (3/4 volume)								
		10	20	30	40	50	60	100	200	300
1	10000	40	80	120	160	200	240	400	800	1200
2	20000	80	160	240	320	400	480	800	1600	2400
5	50000	200	400	600	800	1000	1200	2000	4000	6000
10	100000	400	800	1200	1600	2000	2400	4000	8000	12000
20	200000	800	1600	2400	3200	4000	4800	8000	16000	24000

Table 6
Relative tidal levels, Sagar Tidal Observatory Station, West Bengal

Tidal state	Level (m)	Tidal state	Level (m)
Highest High Water	6.19		
Mean High Water Springs, floods	5.49	Mean High Water Springs, average	5.22
Mean High Water Springs, dry	5.06	Mean High Water average	4.64
Mean High Water Neaps, floods	3.95	Mean High Water Neaps average	3.86
Mean High Water, dry	3.75	Mean Water Level	3.00
Mean Low Water Neaps, floods	2.42	Mean Low Water Neaps average	2.23
Mean Low Water, dry	2.11	Mean Low Water, average	1.51
Mean Low Water Springs, floods	1.03	Mean Low Water Springs average	0.92
Mean Low Water Springs, dry	0.84		
Lowest Low Water	0.21		

Source: Hugh River Tide Tables, Surveyor General of India, 1987.

The design is thus based on the smallest spring tide range during the *dry* season for *high, filling tides* and the smallest spring tide range during the *wet* season for *low, draining tides*.

The approximate distribution of tidal levels, according to tide tables, is

HWL : 3.75 m (5); 3.75-4.00 m (8); 4.00-4.25 m (15)
LWL : 2.00 m (5); 2.00-1.75 m (12); 1.75-1.50 m (30)

Thus, high water level (HWL) is set at 3.75 m
low water level (LWL) is set at 2.00 m

The figures in parenthesis are out of an approximate 240 low and 240 high tides during spring tide cycles every year. In most cases variations between successive tide cycles ensure that even these extreme values are followed in the next cycle by tidal levels within the normal design range.

Using the above tide levels, it is possible to define the amount of water capable of flowing through a sluice of a specified size on any particular tidal cycle. In practice, this is usually based on the 'critical tide' which is the spring tide having the lowest range. In this case, a fully-flowing culvert formula, corresponding to standardised pipe sizes locally available, is used. Appendix 1 shows typical calculations. For greater simplicity of use a range of such calculations has been collected to provide the series of graphs shown in Figures 2a and 2b, which make it possible to predict

Figure 2a : Relationship between changes in interior water levels for any given tidal difference and standard pipe size for 10 ha and 5 ha water areas.

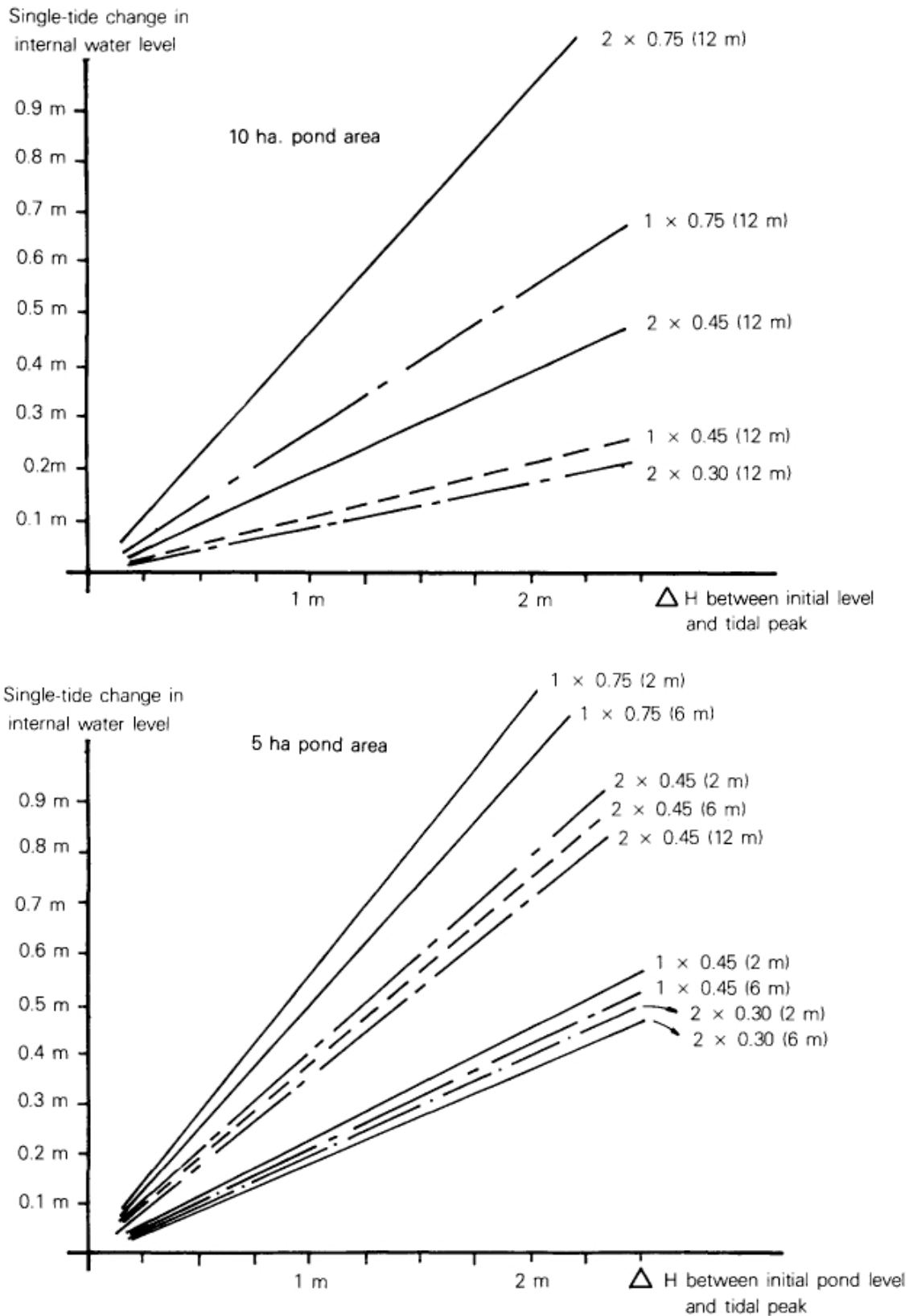
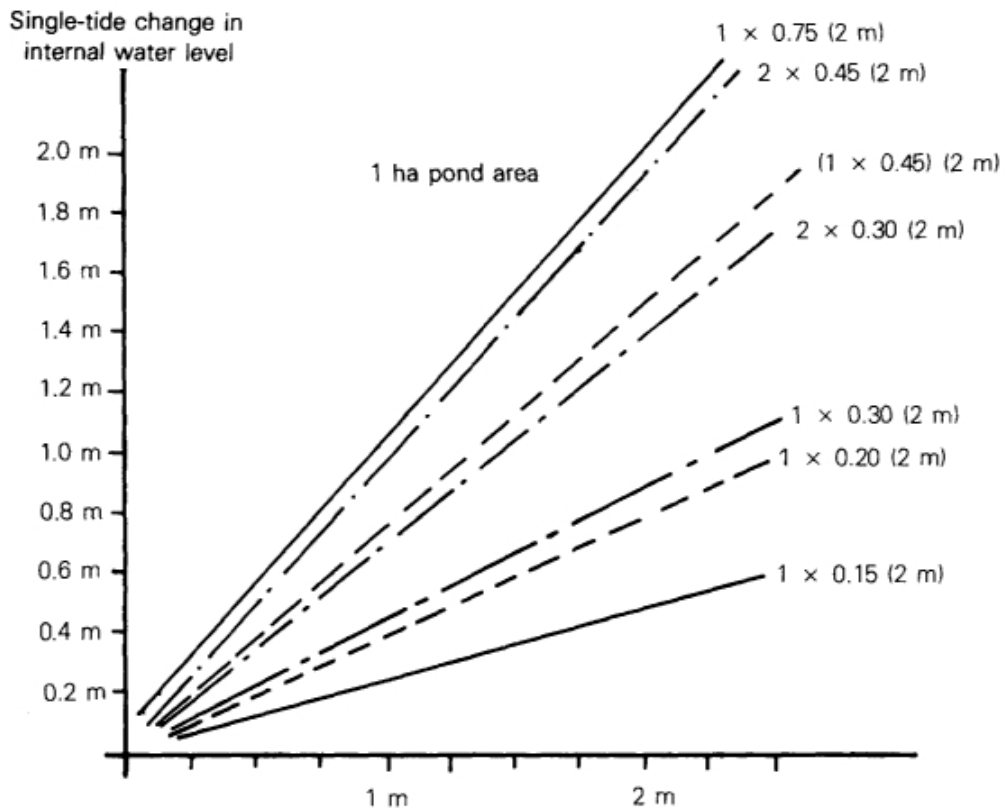
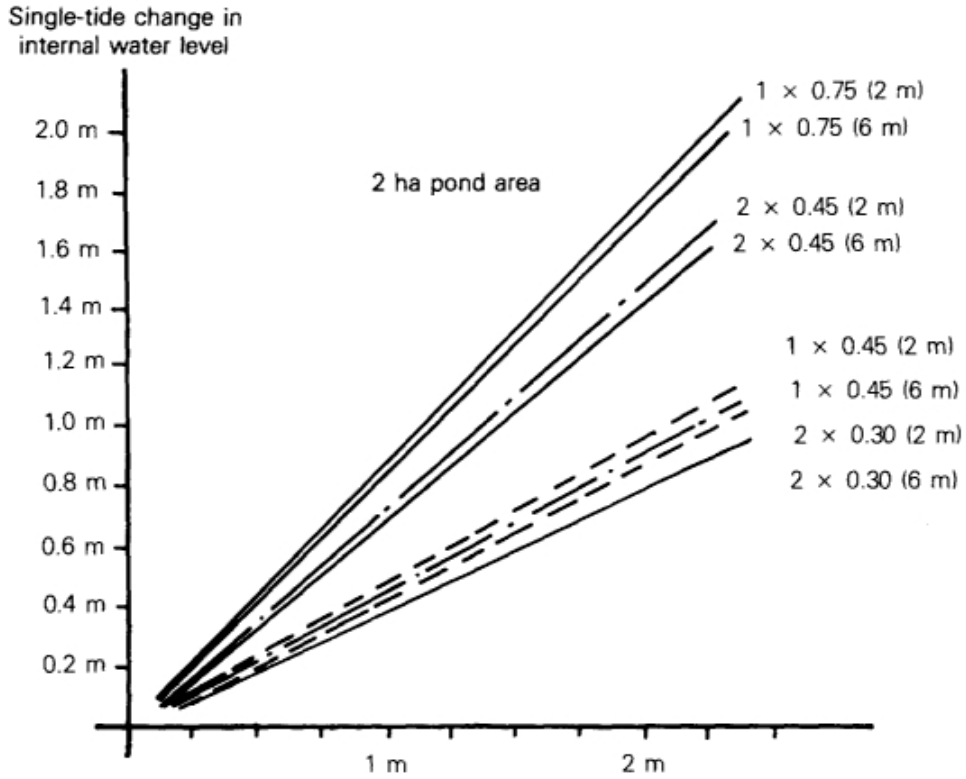

Figure 2b : Relationship between changes in interior water levels for any given tidal difference Et standard pipe size for 2 ha and 1 ha water areas.



the change in interior water level for different interior water areas, for any given tide, using standard pipe sizes. Though based on the 'design tide', the graphs will enable water exchange to be calculated for any tide. Thus, for a 10 ha interior water surface, if the peak tide level is 1.5 m above the internal level before filling, one high tide will raise the internal level 0.4 m, if a single 0.75 m pipe is used. For the next high tide, the interior level is raised 0.4 m; given a similar peak level, the difference is now $(1.5-0.4) = 1.1$ m, and the increased level after filling will be 0.3 m. In this way, it is possible to work out

- What size of pipe and how many are needed for a specified exchange in one tidal cycle. For example a 25% exchange of a 1 m interior depth requires the draining and filling of 25 cm of water.
- How many tidal cycles are needed to fill a specified amount using a particular pipe size (as suggested in the example given).

This permits a suitable sluice size to be selected for a range of conditions, the normal procedure being

- Establish the tidal range characteristics for the specific site.
- Determine the 'critical tide' – the smallest tidal range, and hence the minimum tide height, in which water is to be exchanged. Water can also be changed on neap tides if the range is sufficient.
- Decide how much of the water in the system is to be exchanged, either on a single high-tide cycle, or over a series of spring tides, and what this implies for the drained water level inside the system before filling up. For example, a 1 m deep system exchanged 25% would need to be drained and refilled by $1 \text{ m} \times 25\% = 25$ cm.
- Calculate the difference between the pre-filling level and the high tide level of the critical side, and using the graphs, work out either the size of pipe needed to fill the system in the single tide, or a spring tide cycle, or the number of tides required to fill the system using specified pipe sizes.

A further factor in the design of sluices is the ability of the system to discharge excess fresh water during heavy rainfall. As many of the systems have only single sluices providing both supply and drainage, additional capacity may be required to allow adequate drainage. As Table 7 shows, the expected average flow rates are within those required for sluice sizing (see Table 5) provided water was allowed to lie in the internal area for several hours, to cope with peak rainfall. In many systems, the existing simple overflow cuts could also handle excess fresh water.

Table 7
Calculation of rainfall runoff

Assuming a maximum daily rainfall of 500 mm/24 hours, on 40 ha:

$$\text{Total volume} = 400,000 \text{ m}^2 \times 0.5 \text{ m} = 200,000 \text{ m}^3/24 \text{ hours}$$

Assuming a peak intensity of 3 times the average intensity,

$$\text{Maximum, peak flow rate is } 200,000/24 \times 3 = 25,000 \text{ m}^3/\text{hr}$$

This would be within the planned overflow capacity of the system provided it were possible to allow the freshwater to lie on the plot area for sometime. If peak flows were to be handled, it would be necessary to open drainage sluices beyond normal limits.

2.1.3 Sluice design and construction

A number of different sluice designs have been developed, with the aim of improving durability and efficiency of operation, and of reducing costs, if possible, by using local materials and construction techniques. Some of the designs (see Fig-3) are relatively experimental, and would probably be most appropriate for limited-lifespan use, where their low initial cost would be advantageous. The main options considered are

For external and internal sluices

- conventional concrete “hume” pipe system
- tar or oil drum pipe
- bamboo cement pipe
- wooden box system

For internal sluices only

- wooden plate system
- simple wooden “baffles”

The water control structure itself would be of either wood or brick construction. The systems are compared with the present ‘cut and fill’ sluices, as shown in Appendix 2. Predator control would be achieved using a combination of screened sluice boards and internal nets — either sock nets fixed to the water control structure, or staked screens set in the receiving water channel, or both.

A critical factor affecting the choice of sluice design is the effective annualised cost of the sluice. As different designs are likely to have different working lifespans, there is normally a choice between a low-cost limited life sluice, or a higher-cost longer-life sluice. Over a longer duration, the higher-cost option is frequently cheaper, but if the project itself is limited in lifespan, or may be changed in concept, or if for example an operator holds only a limited lease on a site, it would be wasteful to use an expensive, long-lasting system. Table 8 illustrates some of the comparative costs for the different systems. It should be noted that the actual lifespan of the different sluice options cannot be accurately defined for local conditions. The lifespan of many systems can be improved with good construction and maintenance, thus lowering the annualised costs.

Table 8
Comparative costs of sluices : Effects of lifespan or period of use

Figures in asterisks are the lowest for that type of sluice. Figures in italics show the lowest-cost sluice for a particular lifespan or period of use. In practice, careful maintenance should help reduce these costs.

Type of sluice	Annual cost (Rs.) for period of use, years				
	1	3	5	7	10
Cut/refill	576	576	576	576	576
Barrel/wood	2770	923	<i>554*</i>	791	<i>554*</i>
Barrel/brick	3110	1037	622	<i>651</i>	<i>456*</i>
Bamboo/wood	<i>2413</i>	<i>804</i>	701	846	<i>592*</i>
Bamboo/brick	2753	918	769	706	<i>494*</i>
Concrete/wood	5990	1997	1198	1044	<i>731*</i>
Concrete/brick	6330	2110	1266	904	<i>633*</i>
Wood/wood	5150	1717	1030	1471	<i>1030*</i>
Wood/brick	5490	1830	1098	1331	<i>932*</i>

2.1.4 Protective works and silt control

One of the problems with existing sluice arrangements concerns the protection of dike and channel areas in the vicinity of the sluices themselves; there were several examples of severe scouring failure of sluice works. It is therefore critical that adequate scour protection be provided and that the dikes are suitably strengthened, and protected from seepage, which will also contribute to localised scouring. Figure 5 illustrates the ways in which protection may be provided. The ways in which the sluice gate site itself may be protected from excessive exposure are also shown (Fig-4). Two experimental options for reducing the problems of dike strength, seepage, and water control in the widely varying river regimes would be to:

- Use a ‘double-decker’ pipe system, with the lower pipe for use during the dry season and the upper pipe during the wet seasons. This would be more expensive to install, but would reduce the risk of scouring through a low-set pipe during seasonally high tides.
- Use an internal reservoir. This could be used to provide a supply buffer for the pond areas, and could also act as a pressure-equalising system during extremely high tides.

The costs of several alternative methods of protection around the walls, wings and floor of the sluice itself are described in Appendix 3. As with the sluices themselves, the lower-cost options are likely to have a more limited lifespan, and may require higher levels of maintenance. However, in all cases, it is important that operators be aware of the need to restrict flow velocities when there are large differences between internal and external water levels. For internal sluices, scour problems are not nearly so severe, and simple bamboo screening and/or regular preventive maintenance is usually sufficient.

Silt removal and control is one of the most difficult aspects of the design and management of brackishwater systems in this area, as extremely high silt loads are present in the river. Once water velocities decrease below those of the main river flow, silt begins to deposit, and can be removed hydraulically only by scouring velocities considerably higher than the settling velocities. In practice, this means that sluices which normally have high velocities can scour silts, but channels and ponds will normally allow silt to settle. There are several strategies for dealing with this

- Reduce the quantities of silt entering the area, either by selecting water from the surface layers, or by allowing silt to settle in a natural basin or quiescent zone, or in a specifically built settling area.
- Allow the silt to enter, and let it settle in a specific settling area. The accumulated silt can either be dug out by hand, or drained out by purposely creating scouring velocities during low tides.
- Allow the silt to settle in the ponds themselves, and dig or drain it out on a routine basis.
- Allow the silt to settle in ponds, channels, or reservoir areas with the aim of gradually building up levels, eventually reclaiming the land for terrestrial production. This might be feasible in low-lying areas, where most internal material is used for dike construction, or where it is intended to reduce the water area progressively.
- Use a combination of these strategies.

As the details of the silt particle sizes and their concentration in the river waters are not known, it is difficult to make precise specifications. However, Table 9 shows the typical settling area required for the range of particle sizes likely to be present, based on a range of flows.

Table 9
Settling areas required for silt removal

Particle size, mm	Settling velocity m/sec	Theoretical area required, m ² for flow, m ³ /hr			
		1,000	2,000	5,000	10,000
0.006	0.00001	28,000	56,000	140,000	280,000
0.01	0.00003	9,300	18,700	46,700	93,300
0.02	0.0003	930	1,870	4,670	9,330
0.06	0.001	280	560	1,400	2,800

Note : This is based on theoretical settling time, with a particle density of 2.0.

The size of a particular settling area will therefore depend on the relative fractions of particular silt sizes, the amounts required to be removed, and the flow anticipated in a particular system (see earlier Tables for typical water exchange flows). To give a practical example of the quantities of silt possibly entering, an exchange of 50% of water in a 10 ha water surface 1 m deep requires 50,000 m³ of water. If this has a silt load of 5000 mg/l (not uncommon), of which 90% settles in the system, 50,000 m³ x 1000 l/m³ x 5000 mg/l x 90% x 10⁻⁷ mg/t = 225 tonnes of silt, occupying approximately 100 m³ of pond. With 100 fill cycle, this produces 10,000 m³ of silt, or 10% of the pond volume.

Figure 3 : Alternative sluice designs

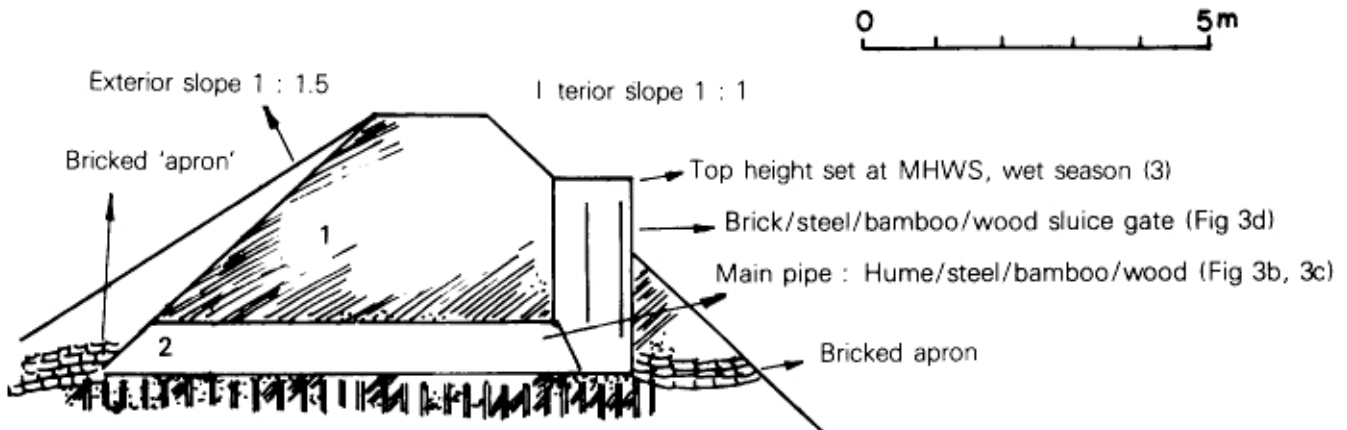

Stabilising piling (optional on pipe), bamboo, 1.2 m length, at 40 cm spacing (pipe), 25-30 cm spacing (gate). Gate, if brick, may also have 20 cm coarse crushed brick below base.

NOTES

- (1) In exposed areas, slope over exterior end of sluice should not exceed 1 : 1. In sheltered areas, this can be steepened, but bamboo piling reinforcement may be needed (see Figure Sb).
-) During wet season flood tides, a simple wood/bamboo flap can be set, to limit or close off incoming water.
-) To save weight/cost, the gate can be set lower, flow being controlled by an external map/board (see note 2)
-) Wa)) areas near pipe inlet/outlet should be reinforced, at least with bamboo poles/matting. Where exposure/high velocities are expected, brick/concrete should be used.
-) End of pipe should have an up and footing cover to prevent seepage.

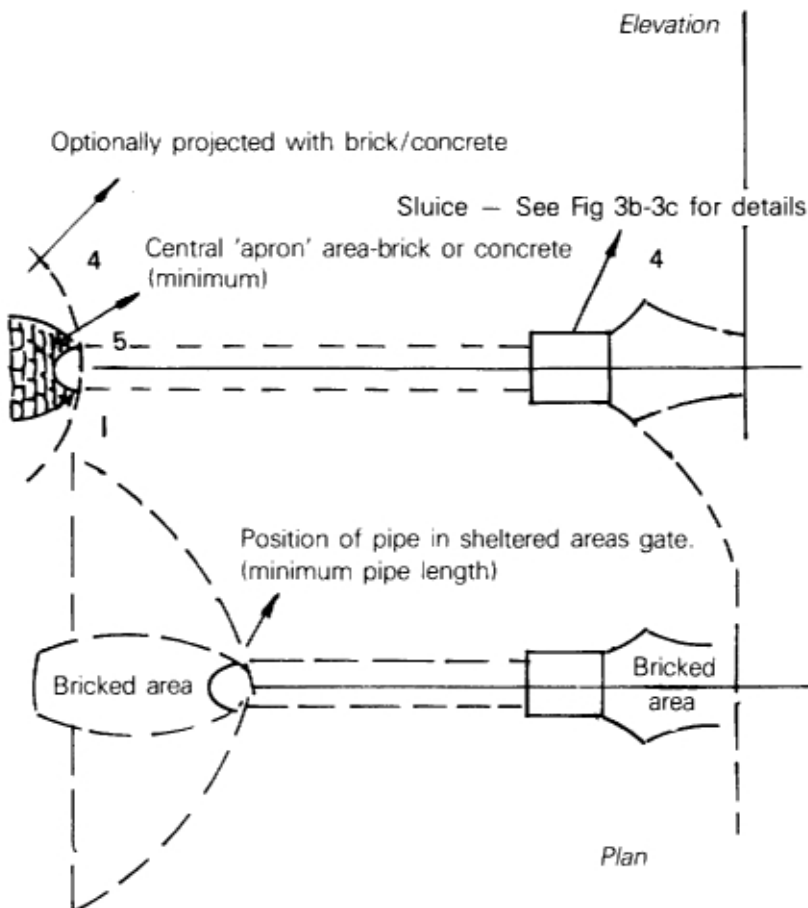
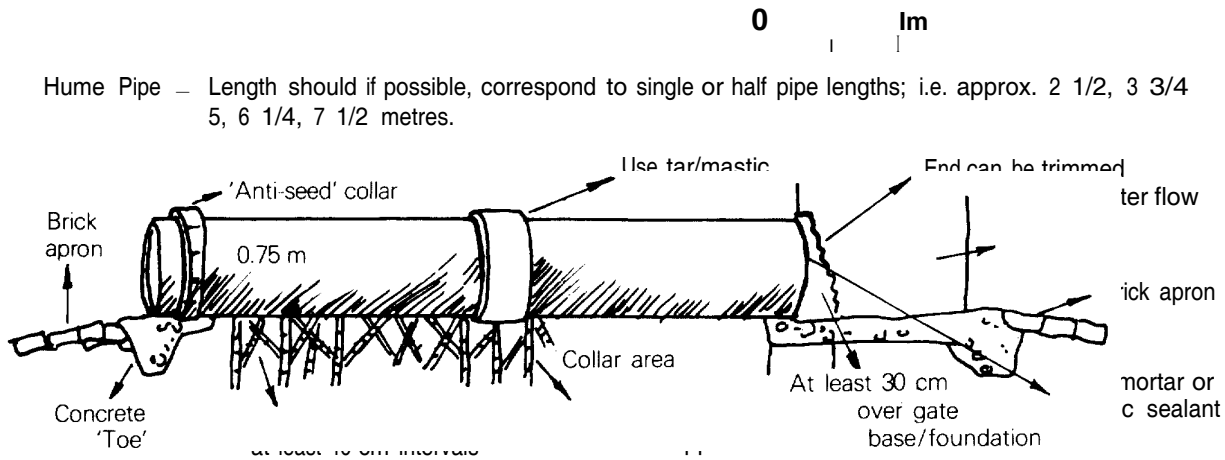

Figure 3a : Exterior sluices : general layouts/sections

Figure 3b : Main sluice details



Hume Pipe – Length should if possible, correspond to single or half pipe lengths; i.e. approx. 2 1/2, 3 3/4, 5, 6 1/4, 7 1/2 metres.

Other Notes

No. of collars inside dike should be minimised.

The pipe can be set without stabilisation, but will risk a far shorter use-span before repair.

Use tar/mastic sealant around collar for flexible joint – this will still work even if pipe shifts slightly.

A concrete or brick 'ring' fixed round the pipe near each end, possibly in centre sections, as wide as convenient, can help stop seepage. Wood or bamboo can also be used, if a good bond can be made with the pipe.

'Oil-drum' pipe :

– Allow about 1.0-1.2 m length per drum

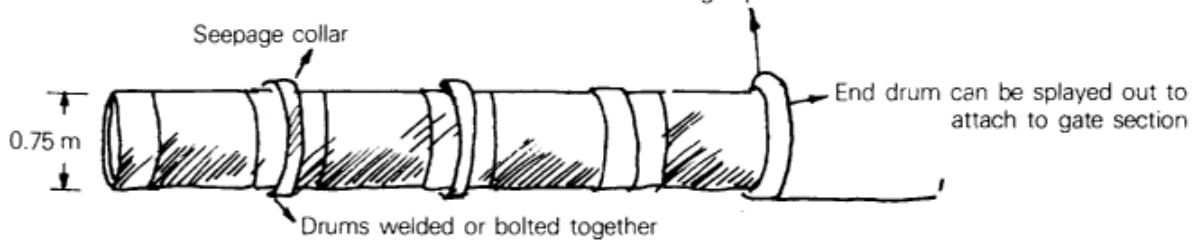

Notes

A lighter foundation, with the minimum of front and rear 'toes' to stop erosion and seepage, can be used. For limited-span use, no piling, etc. is necessary.

- Pipes can be welded, either butt end to butt end, or splayed out, as shown, and welded or bolted face to face. Joints should be liberally coated with tar, bitumen, or mastic. Joints can also be made by 'bellling out' one end, and slotting another into it, then welding, bolting or sealing with mastic.



Anti-seepage collars can be made by splaying out ends, or by welding a separate 'collar' e.g. from drum ends, around the drums.

- Try to keep inside as smooth as possible, to permit free flowing of water.

Figure 3c : Main sluice details

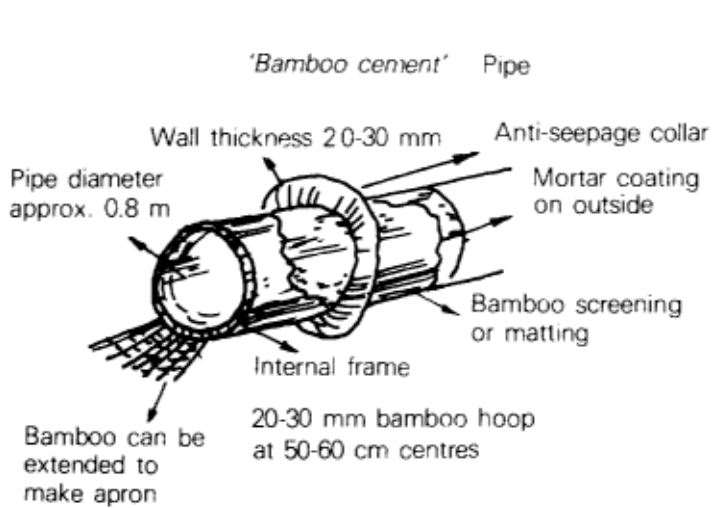

Notes :

details, etc. as for oil drum pipe, this type can be directly lined, etc.

The collar can be formed by plastering around the main pipe, with the ends outwards.

It can be made using a clean oil drum as a form, or if the matting is tight, simply plastering the matting from the inside, using a 1 : 5 to 1 : 7 sand mix.

- A simpler, lighter structure can be made with tightly woven matting by tarring the outside of the pipe. This is not likely to last so long.
- Ideally, the pipe is made before placing. However, if needed, the pipe can be placed, and plastered from inside and outside, in situ. To reduce salt water effects the area should be dewatered.

- For additional strength a second layer of matting can be laid into the wet mortar, and the pipe coated again.
- Alternatively a square section structure can be used, though this will not be so strong.

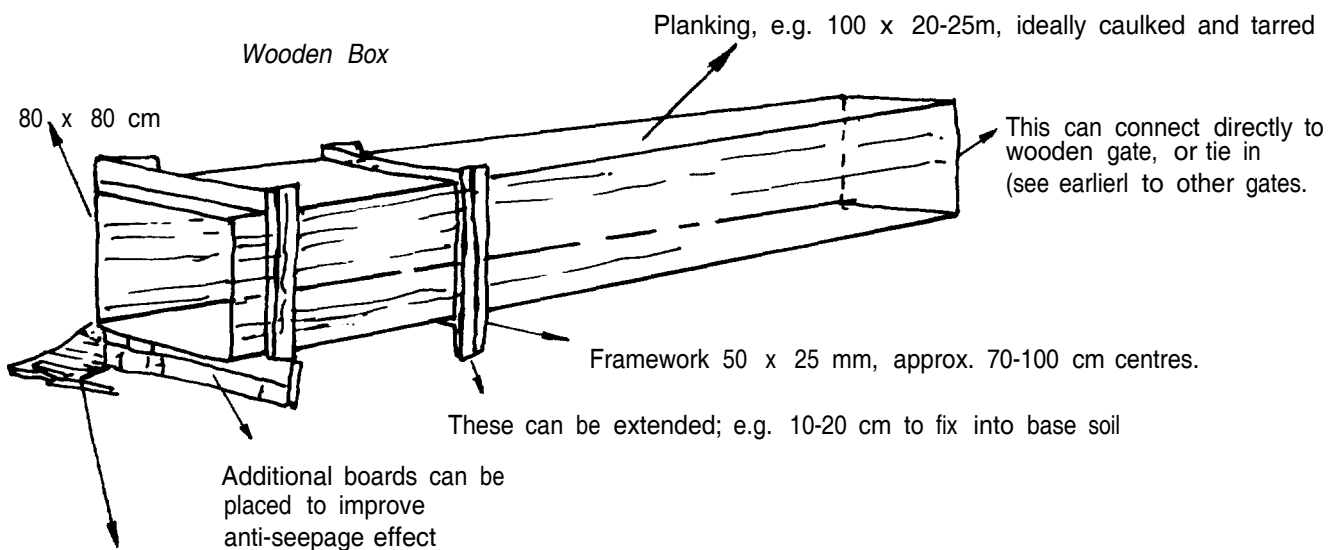

Boards can also be extended to form apron.

Note For 'double' pipe systems, do not make box wider than 80-100cm. Unless internal bracing on mid-line is provided. Alternatively, make a double box with an internal wall.

Figure 3d : Main sluice details

Gate: Brick – Conventional gate, needs heavier foundation, more suitable for exposed locations, more permanent structures.

If brick face exposed make sure painting is sound. Otherwise, plaster with 1:5-1:7 cement/sand.

Notes : This is the minimum size suitable for a single 75 cm pipe.

- Single sluice board width should not exceed 80-100 cm, to minimise bending and difficulty for moving board.
- Boards may be sealed by fixing a flap of rubber (e.g. inner tube) along bottom edge. See below – Guide rails may also be lined.
- For taller brick sluices, it is better to use double brick for at least the first metre. Abutments (see plan) can be used to stiffen the wall.
- For absolute security, complete gate.
- Pipe should be based on concrete foundation.
- Areas in contact with soil should preferably be plastered.

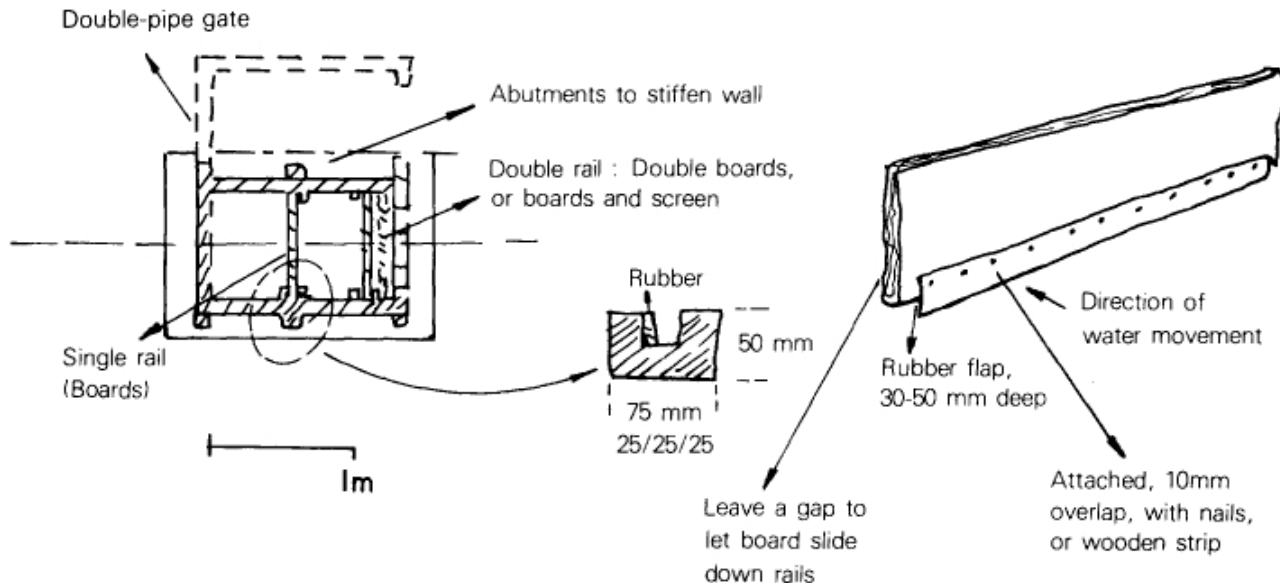
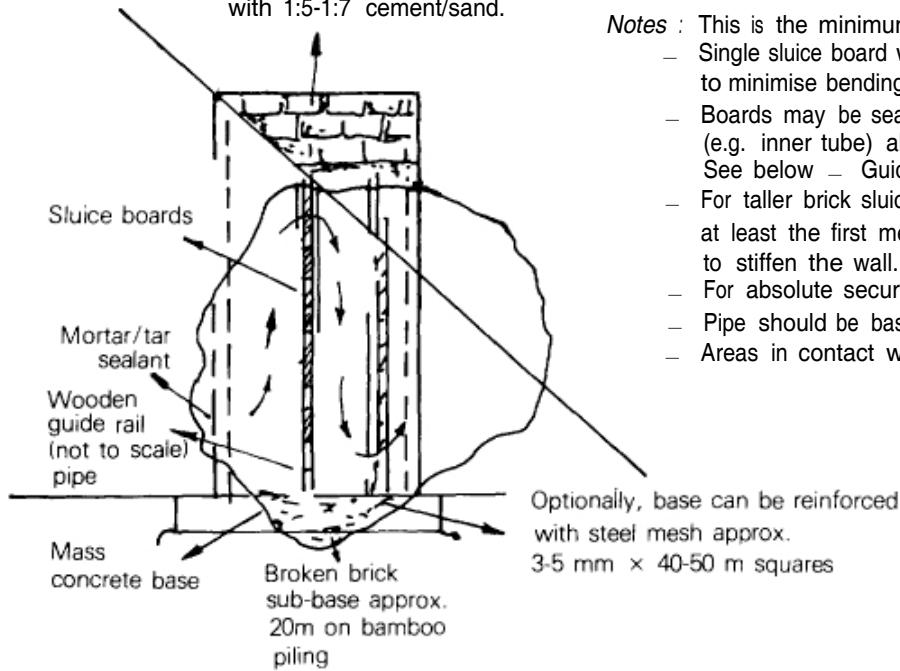

Other Notes : Gates of similar general form may be made using wood, bamboo cement, or steel (flattened out oil drums). See previous figures for general construction principles. These can normally be supported on a lighter, simpler foundation.

Figure 3e Interior sluices

Note : Many of the designs for exterior sluices may be modified for interior use, with the following points to consider

- Foundations are not normally important.
- A simple water control on the end of the pipe/box is sufficient - there is no need for a vertical gate box.
- Sluices may be moved from location to location.
- There is normally no need to fill in the dike across the top of the sluice.

Wooden Box - This is similar to the type already used

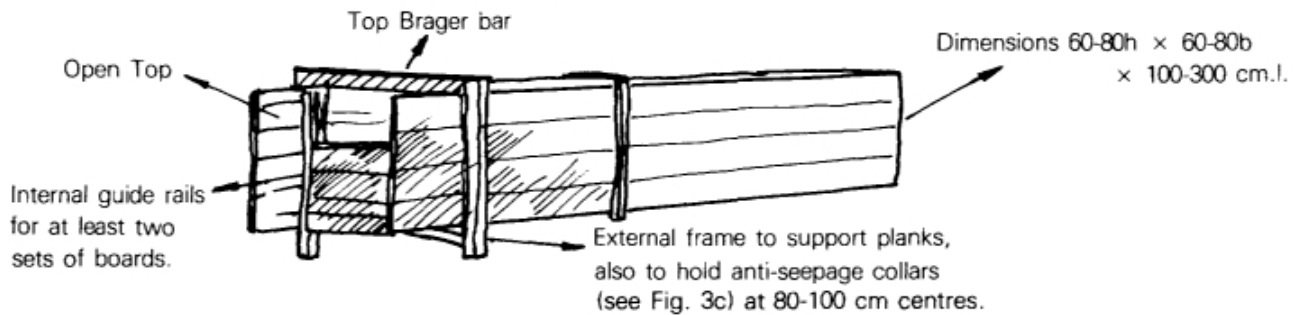

Note : Timbers can be lighter, sealed with tar, or simply with clay. The main improvements suggested over existing designs are :

- Make at least two anti-seepage collars per sluice, projecting at least 10 cm, preferably 20 cm or more, around box.
- Use rubber flaps (see Fig. 3d) on sluice boards.
- Minimise length, but make sure 'apron' areas are well protected - e.g. extend planking, use matting, etc.

Plate Sluice

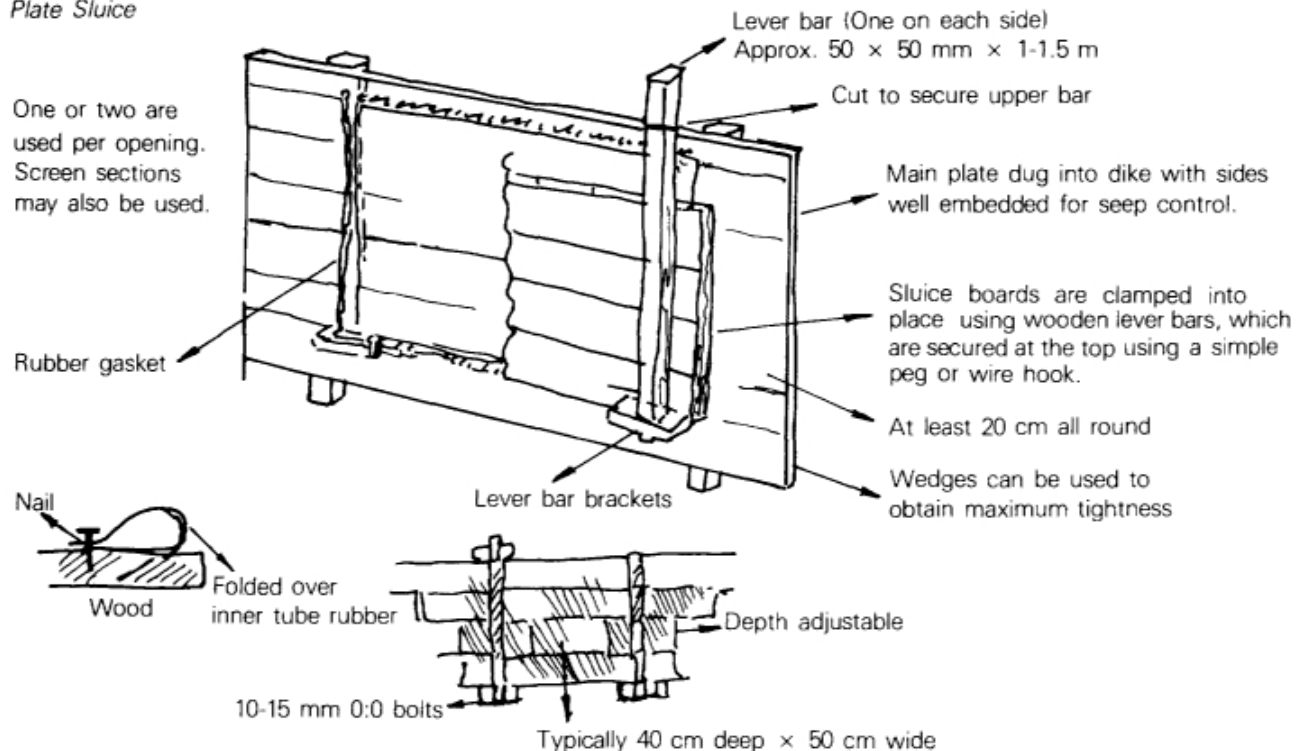
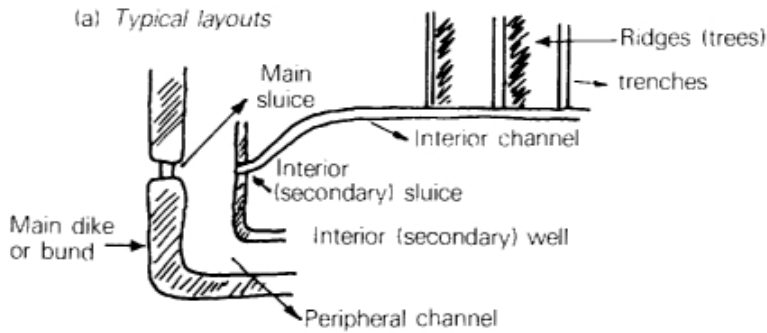
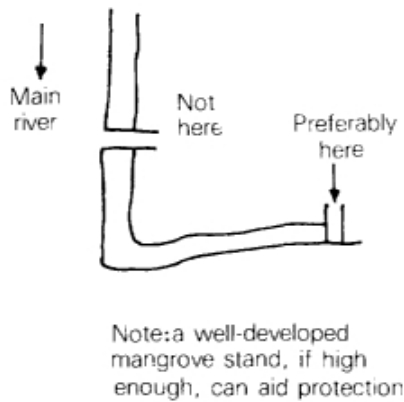

Figure 4 : Methods for protecting sluice gates



(b) *Main sluices*



If sluice needs to be built on an exposed river location, it must be strongly built and well protected. Alternatively, use

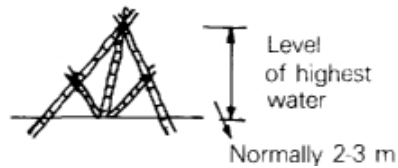
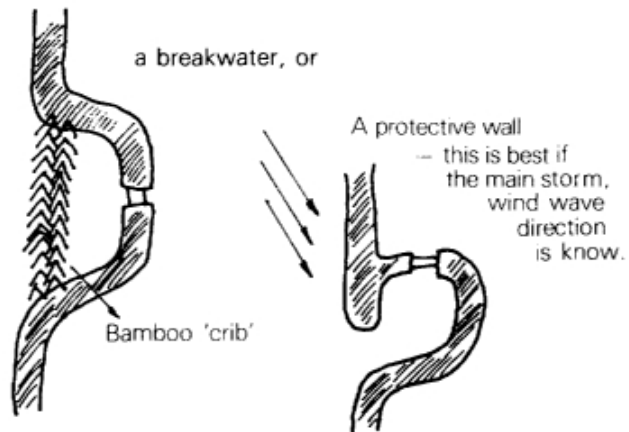

(c) *Interior sluices*

A sluice or water control should be used.

- Between peripheral channels, nursery ponds and interior areas.
- At the end of individual ponds
- At the ends of trenches.

Figure 5 : Erosion protection devices

a : Overflows, barmes

The simple screen overflows currently used, if maintained properly, are probably adequate, though these should be sized carefully. A more robust version is shown below.

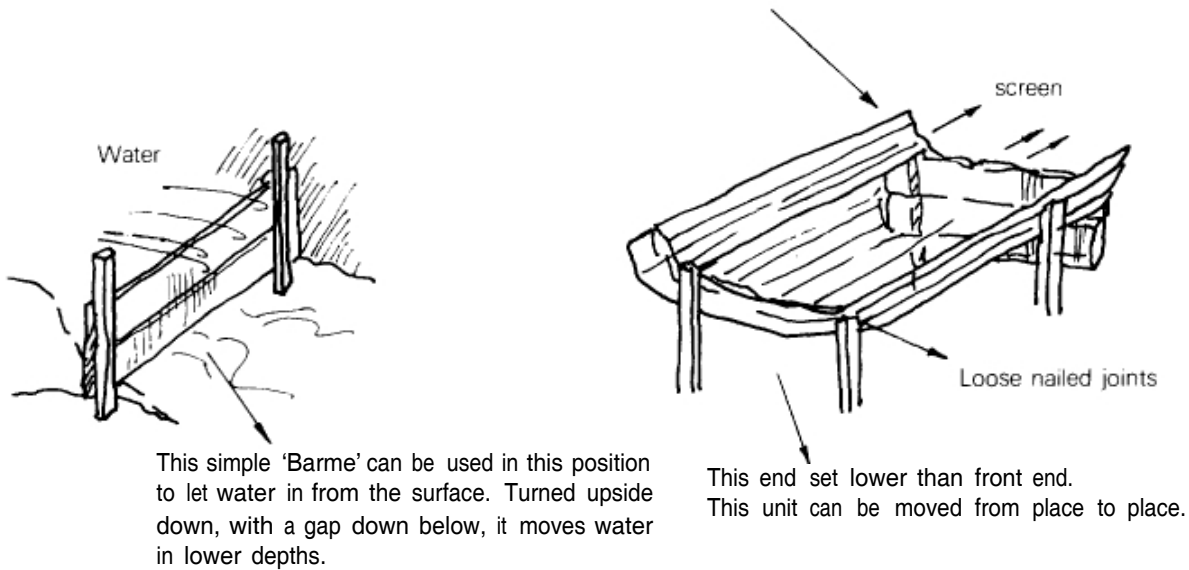

b Dike reinforcement

If a narrower dike area is to be used over a sluice pipe, it may be useful to reinforce it internally with bamboo piling, to minimise any risks of instability if high external water pressures are caused at high tides

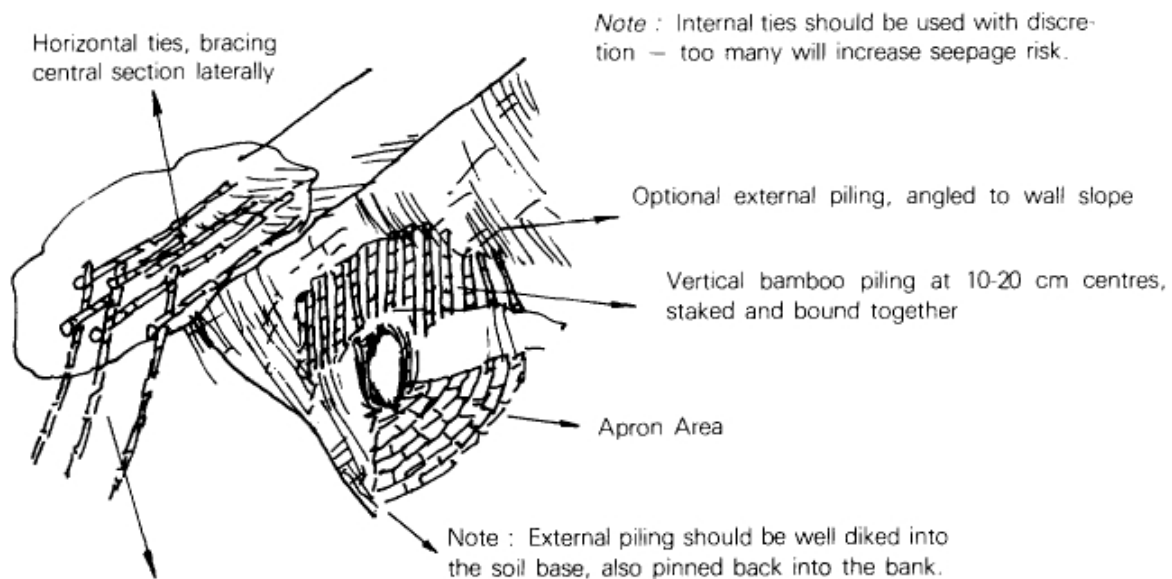

Diagonal ties inside the dike, pinning central area to larger dikes on both sides. Ties typically 5-6 m long.

2.1.5 Future prospects

The main priority of work will be the clarification of the tidal levels at each site. Details of a simple tide level gauge, and the way to relate results to land levels are given in Fig-6. This information is basically not difficult to determine, and local staff should be quite capable of carrying this out. Ideally, one year's monitoring is recommended, but with care, reasonably good approximations can be made by comparing a more limited series of data with the published tide tables. As one of the main problems with current water management is the uncertainty about the potential for tides to fill pond areas, this information will quickly enable the water exchange potential of each site to be assessed.

The range of sluice designs described could all be suitable for use. The first and most important step will be to define the sizes required for local tidal conditions and the desired water exchange. The earliest practical time for sluice construction is likely to be after the monsoon, perhaps November-December, though conditions will be slightly easier as the area becomes drier. This would not of course be based on full tidal data. Table 10 shows the main sluice options for different applications.

Table 10
Sluice design options

Location	Sluice option
Exposed external areas	Reinforced single level or 'double-deck' pipe. Simple cut and fill with stop-log and screen
Sheltered external areas	Normal single or 'double-deck' pipe sluice. Simple cut and fill as above. Reinforced wooden box or plate sluice
Internal 'secondary'	Simple cut and fill as above, but smaller. Simple wooden box or plate sluice. Single pipe with simple shutter
Internal 'tertiary'	Plate sluice. Stop-log/screen in cutting
Bheri	'Low-cost' bamboo or drum pipe sluice. Cut and fill, with stop-log, etc. Simple box or plate sluice

There is a very valuable opportunity to evaluate low-cost sluice designs. Their cost-effectiveness will be significant to many other brackishwater projects throughout the world, as the potential savings, particularly for limited-life structures, are considerable. The actual choice of sluice types for local use will depend partly on the aims of the silvipisciculture project. With short-term use, the bamboo cement and oil drum pipes, with wooden water controls, could be particularly useful in sheltered conditions, even the simple plate-type sluice could be used for external dikes.

Appendix 4 gives details of the cost outline of the project for one 40 ha complex. It shows a gross return ranging from a loss of Rs.6,700 to a profit of Rs.9,300 per year. It is also seen that the overall potential of the project is highly dependent on aquaculture yield, particularly from high value species. The viability of the unit is also highly sensitive to construction costs; considerable difference in cost may result from the different quantities of earthwork required for specific layouts or site levels. In a nutshell, sophisticated or extensive forms of construction or operation, unless warranted by improved production, are unlikely to be profitable.

The overall strategy of use of the areas deserves further consideration, and should be resolved between the external funding agency and the West Bengal Forestry Department, as this will have a significant bearing on the acceptable costs of development, the extent of silt control required, and the longevity required of water control structures. If the systems are to be moved towards terrestrial production, aquaculture revenues may not be sufficient to support the costs of development. At the very least, significant savings in construction and maintenance cost would be required.

The layout and management of silvipisciculture projects in general could benefit from further development, if it is intended that they continue to be aquaculture-oriented. Table 11 shows some of the main points to consider. Most of the systems would benefit from a more carefully planned

and engineered approach, aiming to maximise the potential productivity and environmental quality, while minimising costs. Associated with this, there is the potential for a certain level of simple applied research, particularly relating to pond management, productivity and yield. There could be some benefit, if these projects are to continue and to develop, in carrying out small workshop sessions covering site selection, tidal ranges, water management, assessing relative land, pond and river levels, local construction and maintenance, pond management, and record-keeping.

Table 11
Water Management

- A single gate, well managed, may be better than a double gate of better capacity, but poorly controlled.
- A system of separate inflow and outflow, ideally at opposite ends of the ponds or pond complexes, provides for better water exchange in properly managed conditions.
- A single gate for inflow and outflow may be better, if well managed, than a poorly run system of separate inflow/outflows. By setting up separate inflow and outflow routes to the single gate, moderately good exchange can be achieved.
- Alternatively, a simple adjustable overflow, with suitable ‘baffles’ may be easier to manage and control than a specific outflow gate.
- Small wooden secondary sluices or ‘baffles’ may be used in branch canals and trenches to improve water exchange between these areas and the main water area.
- A reservoir/nursery area at the main sluice gate entry may be useful to hold water for exchange later, outside the high tide periods, and equalise pressures around the dike during particularly high tides.
- Overall, the water management system is best kept simple with as few as possible separate gates and control structures.

3.0 Controlled stocking

The objectives of controlled stocking are twofold – to maximize revenue by cultivating the most valuable species and to efficiently utilize detritus for fish production. Several species indigenous to the Sunderbans – the mullets (*Liza sp* and *Mugil cephalus*) and the tiger prawn (*Penaeus monodon*) – can fulfil these objectives.

The fingerlings and fry of these species are seasonally available in the Sunderbans. Post larvae of *P. monodon* can be caught throughout the year but the main season extends from December to early April, peaking in January and February. Although there are no data on hand, mullet fingerlings may be abundant during the same period since they are stocked in bheris during January and February.

3.1 The culture cycle

Salinity and tide are the predominating environmental variables controlling the culture cycle. Information received from the manager of a shrimp culture project at Kharkali Island indicated relatively minor salinity fluctuations even during the rainy season, about 14-16 ppt between June and August. These salinities are considered ideal for tiger prawn culture and are well within the tolerance of mullets.

Tide controls the culture cycle in the Sunderbans by restricting the opportunities for filling the trenches of the silvipisciculture units with brackishwater. Filling is possible only during mean high water springs due to the difference in elevation between the trenches and mean sea level.

The elevation of the trenches must be known before the length of the culture cycle can be determined with any degree of certitude. However, anecdotal evidence collected in the area indicates it should span the time between February and September, or about eight months. This is sufficient time to produce tiger prawns of 30 to 40 count. The growth potential of mullet is less clear, but one may suppose they can reach at least 100 g during this period.

3.2 Stocking rates

Several years’ experience will be required to determine the optimum stocking rates for prawn fry and mullet. One must keep in mind that although these organisms are not directly competing for

Figure 6 : Establishing local site and dike levels

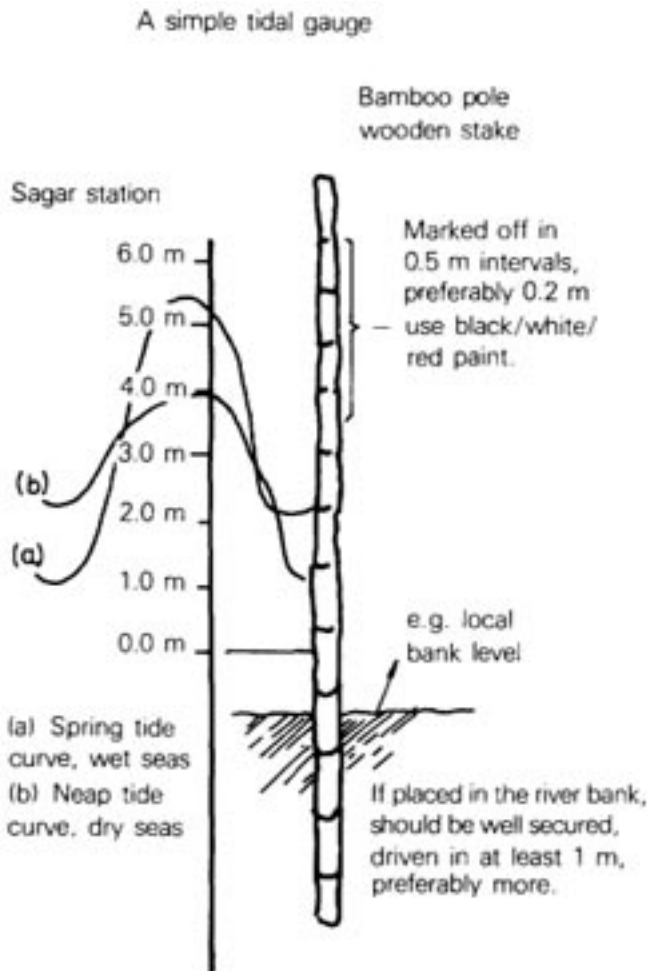

Things to Check

- The relative levels of tides and site.
- The seasonal (monsoonal) changes in tide level.
- The shape of the tide curve (see below).

- Notes :* The local tidal gauge should be firmly set – well embedded in bank side, or attached to a well fixed, stable structure.
- As an additional precaution, its level should be determined relative to a fixed local ‘benchmark’, which should be established at each site.
 - The benchmark should be a fixed, permanent, easily recognised and used point, from which interior wall, pond, and channel levels can be determined.
 - If it is too difficult to set up a single gauge covering the complete tidal range, use two or more gauges, as long as their marked levels match properly.
 - Set the 0 point on the gauge at approximately the lowest low water level seen or known. Tide levels, and the bench mark, can be related to this point, which would be the ‘Local Datum’.
 - If irrigation /hydrographic survey indicates that the actual 0 datum is different from this, the levels can be corrected accordingly. However local relative levels are all that are needed for planning site elevations and water management.

Changes in the tidal curve

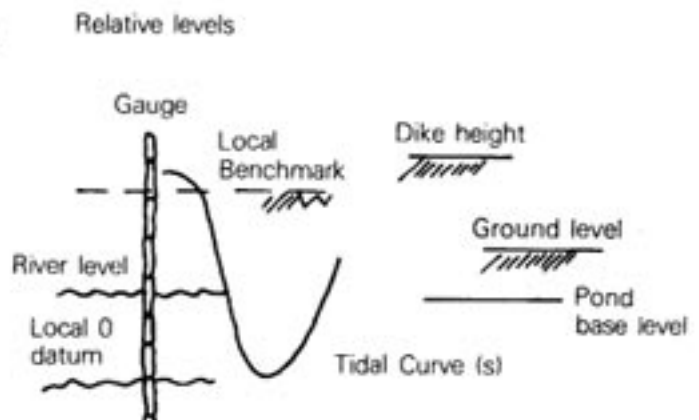
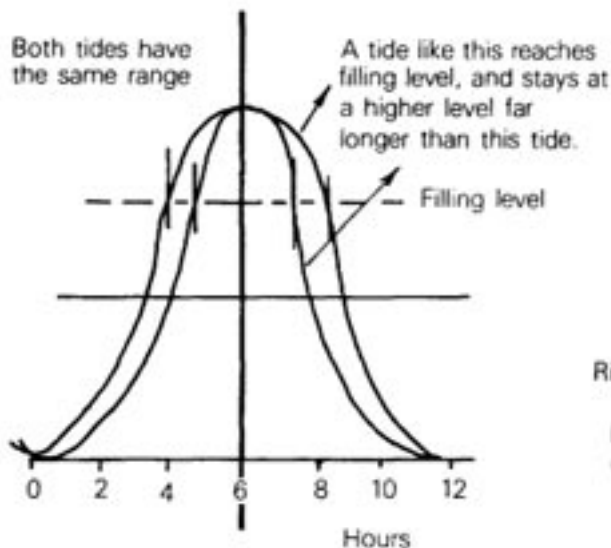

food, the feeding activities of mullet consisting of direct ingestion of detritus, may affect the natural production of prawn food. From the experience in Indonesia and the Philippines – where polyculture of prawns and milk fish is based on natural production of food organisms – stocking rates of 10,000 post-larvae of *P. monodon* per ha and 1,000 fingerlings of *Liza tade* and *L. parsia* per ha can be recommended.

Several stocking rates can be concurrently tested since each silvipisciculture complex has several units. Where three units are available, the following combinations can be tried

	Liza species/ha	P. monodon/ha
1	500	15,000
2	1,000	10,000
3	1,500	5,000

The mix of mullet species will have to be determined through experience. If *Mugil cephalus* is available, it should be stocked in preference to other species as its growth is about three times faster. Unfortunately, it is rather scarce and it may prove difficult to obtain sufficient fingerlings.

3.3 Harvesting

Fish and prawn growth should be monitored fortnightly to indicate when they can be harvested. Cash flow can be improved through partial harvesting of prawns. Marketable sized prawns will be available between 60 and 90 days after stocking. If prawn fry are available, and sufficient time remains in the culture cycle, restocking can be done.

Several methods can be employed for partial harvesting. Traps are convenient and require little labour. The mesh size of the traps is adjusted to retain only marketable prawns. Cast netting with return of undersized prawns is often convenient. A third technique is to place a trap on the pond side of the sluice gate during filling. Prawns swim into a current and will move into the trap.

Final harvesting is accomplished by complete draining. A bagnet is attached to the drain side of the sluice gate to collect prawns and fish. Cast netting and thorough handpicking are required to ensure a complete harvest.

4.0 Research

The main thrust of research should be directed at determining the best species and stocking rate combinations. As there are several units at each site, concurrent trials can be made during each culture cycle. As tree crops, especially mangrove, increase in biomass, detritus production will grow so that a re-evaluation of stocking rates may be required every few years.

Research should also be conducted to evaluate the use of non-mangrove species as green manure or direct feed, especially for mullets. *Leucaena* species are particularly promising in this regard and where ridge conditions allow, this species should be planted to the greatest extent possible and tested for its effectiveness.

More detailed data are needed on soil conditions, particularly the acid sulphate potential. Soil profiles should be taken at different elevations and the pyrite content and soil pH determined at 25 to 30 cm intervals. Potential acid sulphate problems can be ameliorated to some extent and should be identified, so that appropriate measures can be taken.

5.0 Environmental monitoring

Critical water and soil parameters should be routinely measured and the data recorded. Water quality monitoring would include salinity, temperature, pH and dissolved oxygen. Soil organic content and pH must be recorded to indicate the extent of detritus build up and its effect on soil pH.

6.0 Equipment requirements

Effective water quality monitoring will require a minimum of laboratory equipment, such as salinity refractometers and field test kits.

Fry catching nets are widely used in West Bengal and an adequate number should be procured for staff. A stocking rate of 10,000 post-larvae per ha will require 90,000 to 100,000 post-larvae per unit. During the peak season, one net can collect 550 to 3,000 post-larvae per day. If 15 days

are allowed for collecting post-larvae, as many as 12 nets might be required; even more would be needed for seed collection during the off season.

The possibility exists of managing water exchange in existing mature mangrove forests to allow controlled stocking. Trenches, bunds and sluice gates could be constructed to allow water management, controlled stocking and harvesting of valuable estuarine species. This concept has traditionally been applied in North Sumatra, but without the necessary refinements. A pilot project should be implemented in an appropriate area to test the concept. If successful, such a variation on silvipisciculture would have very broad applicability.

7.0 People's participation

At the review of the project in November 1985 (say about 2½ years since launching of the project), noting that no village committees had been created till then and that village participation had been limited, it was proposed that these activities should be intensified only when a feasible concept had been developed.

Subsequently at the mid-term review in 1986, noting that involvement of local people in the production and marketing operation is the key to successful and sustainable development, the mission recommended a social feasibility study with emphasis on ways and means to involve the local people in an efficient way.

A preliminary report by BOBP's Senior Aquaculturist suggested the following areas for participation by local communities

7.1 Production:

A study of target communities; identification of indigenous organizations around which to base participation; participation at the producer level on household basis; finding out a mechanism fair to all households; financing through State-sponsored set-ups; an educational activity to promote formation of co-operatives; leasing of water bodies to these co-operatives.

7.2 Marketing:

The co-operative society of producers to take over the responsibility; to cater to the two different channels of marketing, one for fish (through commission agents) and the other for prawns (directly to the processors after taking all the post-harvesting operations up to transportation to the nearest disposal point).

Subsequently, a national consultant was engaged for identifying a village level mechanism for implementing people's participation in silvipisciculture. The salient findings of the study which covered seven villages in the vicinity of SPC complexes were

- Only in two of the seven villages was there awareness of SPC because of the proximity to the Forest Range Office and/or because the villagers had leased SPC plots from the Forest Department.
- The immediate benefit for the people was in terms of employment for the earth work excavation.
- A number of technical problems were identified: inadequacy of mechanisms for controlling water exchange, siltation, lack of maintenance, organizational constraints like the leasing policy being limited to a short period, the seasonal nature of the availability of actual water body in a plot.
- It is necessary to first prove the technical feasibility of SPC to ensure a demonstration effect on the target groups.
- The District Development Committee (Zilla Parishad) and village management committee (Village Panchayat), which are entrusted with the implementation of SPC, would also be the best channels for ensuring target group participation.
- The methodology of participatory programmes would differ significantly between sites, depending on whether they belong to the panchayat or to the forestry department.
- The leasing policy of the FRD should be modified. Instead of auctioning plots to augment revenue, they should be allotted to co-operatives for specific periods on the basis of technical and economic criteria.
- Information dissemination to generate local awareness and interest could be done through panchayats, social non-governmental organizations and registered youth clubs.

- Landless peasantry and marginal farmers must be given priority. Identification of the beneficiary or groups of beneficiaries must be left to village panchayats.
- Training should be an integral part of the programme and would serve as an important instrument to promote participation.

8.0 Conclusions and recommendations

The highest yield obtained from pisciculture in the project – which however was only about 30¾ to 40% of what can be obtained in such polyculture in SPC in mangrove areas – may be sufficient to support the development and operation of such projects. SPC is no doubt dependent on the fishery yields of high-value items and is highly sensitive to construction costs; still, developed on a systematic basis, it offers local people an economic alternative. There is certainly a lot of scope for improving productivity, improving the sluice designs and management of the PSC complexes and increasing community participation in the programme.

While SPC projects appear to offer an interesting, productive and potentially self-supporting means of rehabilitating and stabilising forest areas, certain physical factors have to be recognised and reckoned with. The area is in the depositional zone of the Hooghly river, and over a relatively short period of time, it will get silted up. The choice lies between two strategies

Either the siltation is allowed to build up, pisciculture and other revenues diminish and a fully terrestrial habitat emerges for establishment of non-mangrove forests *or* by desiltation or siltation control, the project is kept for full pisciculture production, revenue from which will exceed that generated by forest production alone. In addition, maintenance and desilting will provide annual employment opportunities for the local people and the scope for participatory development may be greater.

The former is a short-term policy and the latter a long-term one from the standpoint of SPC.

Given the stand of the Forest Department, which views SPC as a transitory phase in the process of conversion to non-mangrove forests, and considers the revenue generated by pisciculture production merely as a means to defray the high costs associated with reforestation, only short term benefits will accrue from SPC. One has also to weigh the benefits accruing to the local people in a reforested area where a part of production from the harvesting of forestry products goes to them.

Non-reserved forest land unused for agriculture is limited in the Sunderbans. Some tidelands are available adjacent to villages, especially where they abut the inner bend of river channels but one cannot quantify, in the absence of a detailed survey, the extent of such lands. The impression is that they are also limited and cannot meet the needs of very many people. This leads to the desirability of focussing on derelict forest reserve lands and on how the FRD might provide access to local communities so that they could undertake SPC. In any future expansion of the scheme, the role of the FRD is crucial in identifying and making available appropriate sites for development. As far as forestry aspects are concerned, the department has the expertise to plan and organise the construction of units and provide technical backstopping and guidance. For pisciculture aspects, technical support and training can be arranged through institutions like the Central Institute of Brackishwater Aquaculture (CIBA).

The Fish Farmers Development Agency (FFDA) for promoting freshwater culture of fishes is successfully operating in West Bengal through a mechanism of implementation by zilla parishads in consultation with member panchayats and perhaps such a mechanism could be implemented for SPC too, under the Brackishwater Fisheries Development Authority (BFDA) on the verge of being established.

The funding can be provided through the National Cooperative Development Corporation and/or Scheduled Castes/Scheduled Tribes (SC/ST) Development and Finance Corporation and Scheduled Castes/Tribal Welfare Department. In other words, funds are accessible in the form of subsidies, loans and grants.

Since the development process is decentralized and implemented through village panchayats in West Bengal, it might be possible to lease units to panchayats who could sub-lease to individuals or small groups. Maintenance and improvements could be financed from Panchayat Development funds. The household must ultimately be the social unit responsible for production management and the logical recipient of income generated by the project.

To summarize, the recommendations are

Short-term

- **Implementation** of improvements in sluice gate construction and water management as suggested in the relevant consultancy report.
- All efforts to be made to improve culture management and adopt controlled stocking.
- Technical training in brackishwater pond management and culture practices for FRD staff.
- Launching of an information dissemination campaign for the village folk to broadcast the progress, the potential and the problems of SPC.

Long-term

Drawing up a new project which would emphasize:

- Direct participation by local **people** in the management, harvesting and marketing of the produce with the guidance and support of a motivator; direct participation could be accomplished through **village panchayats, co-operative societies or voluntary non-governmental organizations.**
- **Proper distribution of forest revenues between FRD and village panchayats.**
- **Technical improvement in pisciculture** management.
- **Collaboration** between all concerned departments.
- Technical training and monitoring.
- **Research** activities, especially on the quantification of relationship between soil, detritus production and fish/shrimp yield.