

The control head

The control head consists of a “control” plastic shut off valve 1 inch (gate or ball valve), and a 1 inch plastic (PP) line filter, screen or disk type, 120 mesh. The control valve is connected directly to the tank outlet and then the filter is installed.

The water pipelines

The water pipelines 20 mm, 25 mm, or 32 mm size black PE pipes PN 2.5 Bars, 50 m to 75 m long according to the size and/or the shape of the land. They serve as main and as laterals laid along the borderline of the field. The very few pipe connector fittings needed are polypropylene quick release compression type. Small size plastic start connectors (adaptors), barbed type, are inserted to the lateral pipelines at spacing according to the rows of the crop for feeding the dripper lines.

The dripper lines

The dripper lines are integrated drip-lines 8 mm or 12 mm size, made of a mixture of Low and Linear density PE to ISO 9260/61, with wall thickness 0.6 mm to 0.9 mm (24 mil–35 mil). The built-in point source dripper emitters are labyrinth type with wide water passages and protection filter to avoid clogging. They are normally spaced at 30 cm frequent intervals. The dripper discharge ranges from 0.5–0.7 liters/h at 1 meter pressure head and from 0.65–0.95 liters/h at 2 m pressure head, depending on the dripper. The average recommended length of the dripper line at 1 meter pressure head, on relatively level ground, is 12–15 m for the 8 mm size and 25–30 m for the 12 mm sizes. They are laid along the rows and push-fit connected to the water pipelines. The total length of the dripper lines for approximately 500 m² lands is around 500 m.

Very often the use of a small pump is essential when there is a number of neighboring farmers with water rights from the same well. In such cases larger tanks for each individual farmer are recommended.

IRRIGATION SCHEDULING

Irrigation requirements

One of the practical difficulties in the concept of the AMT is how much water and when to apply it. The total irrigation water requirements of a certain crop are always the same and depend on the climatic conditions,

the growing season and the method of irrigation application. They can be calculated following FAO methodology. The considerable savings in water with drip and other micro-irrigation are mainly due to the high application efficiencies of the techniques. The total irrigation water needs of most of the annual field crops (vegetables and melons) vary from 300 mm to 650 mm, depending mainly on the length and the time of the growing period.

Number and frequency of irrigations

In the calculation of the water needs the area factor is replaced with the number of plants. Area covered is the number of plants multiplied by the planting spacing. As in the conventional drip irrigation in the Family drip systems the irrigated area and volume of soil is partly wetted and the availability of moisture in the soil is restricted. Then small frequent applications are needed in all seasonal cultivations as well as in perennials. This must always be explained to the farmers who are using drip and other micro-irrigation techniques.

The minimum number of irrigations per season in vegetables can be from 40 (water melons) to 75 (tomatoes) according to the crop and the length of growing period. This varies from 75 days (fresh beans, green onions, squashes) to 170 days (tomatoes). Pulse irrigation may raise the number of irrigations up to 120. The frequency of irrigation normally may be from 1–3 days with an average water dosage of 0.5–1 litre/day/plant at the first stage of growth. During the yield formation the dosage increases to meet the requirements of 1–2 litres/day/plant. Later the daily needs increase up to 3–6 litres/day/plant and at late season, sometimes, 5–7 litres/day/plant. Daily applications are needed. During the stage of harvest the requirements decrease by 10–20 percent. (The higher needs mentioned are for watermelons). **Irrigation Schedules for all crops will be prepared on the spot.**

DESIGN CRITERIA AND CONSIDERATIONS

Area, size and shape

The area can be any agricultural land, planted with field crops in rows of short lengths from 12 to 24 meters located in the rural areas on the mountains or in the plains. The size can be from 250 m² to 1000 m². The standard Family drip systems are designed for 500 m², however smaller or larger fields can be irrigated depending on the crop planting spacing. **The shape should be of normal rectangular or square shape.**

Topography and type of soil

These irrigation systems operate at very low pressures, so flat level lands are recommended and/or uniform sloping fields with slopes < 0.5 percent. The soil can be of any texture, preferably medium and/or fine and with an infiltration rate < 20 mm/hour. Very light sandy soils with high permeability are not recommended.

Water availability

The source of water can be a small hand-dug well, a tub, small seasonal rivers, ponds and ditches or any other which can fill the system's water tank regularly. Hand-pumps, treadle pumps and small diesel pumps are often used to fill the tank regularly. The designed flow of the Family drip irrigation systems offered is around 1.1 m³/h at 1.5 m head.

Water quality

The water should be, as clean as possible although there is a complete filtration system. Chemically it must be of normal pH 6.5-8.4, with low to medium salinity, low sodium hazard and toxicity problems caused by bicarbonates, nitrates or boron. TDS can be from 500 up to 2 000 mg/l (ppm), SAR < 12, RSC < 1.25 meq/l. Most of the seasonal vegetables and the melons are relatively tolerant to boron content from 1.5-2.0 mg/l. But strawberries and beans are sensitive, so the boron content should not exceed 0.7 mg/l and the total salinity not to exceed the 1.5 dS/m (1 000mg/l).

Kind of crops

All data on the field crops, which can be grown under drip irrigation techniques in an area, the growing season in winter and summer time, planting spacing, etc. are known to the local agronomists and the farmers. The table "Useful data on common seasonal crops" is very important for the design of the FDS and any other AMIT. The local agronomists and farmers can give data for any field crop (Figure 15.4).

Special consideration

Duration of irrigation application

In all micro-irrigation systems the irrigation dosage is applied simultaneously to a larger area, but at lower rates per unit of area (plant) in comparison with the other techniques and methods of irrigation. In the

FIGURE 15.4 - FDS dripper lines in China.



FDS the discharge from the dripper emitters is very low, around 0.65 l/h. At the last stage of crop growth many plants need up to 7–8 litres per day, so the duration of irrigation should be almost 5 hours for 1 000 m² land. The duration of irrigation application is directly related with the system flow, the size of the tank, and the number of fillings and the availability of water. E.g. for a drum of 200 litres capacity with a system flow of 1.1 m³/h for a daily application of 2 750 litres of water on 500 m² cultivated land, the duration of application would be 2.5 hours and the number of fillings around 14. This factor should be considered seriously in the planning and designing. Partial water application (pulse irrigation) is recommended during high water demands.

The Installation of the FDS

During installation the connection between the various components and fittings should be made properly, so that water will not leak. Leaking may affect seriously the performance of the system. Teflon plastic tape is used in all threaded connections. In FDS, like in all pressurized systems, when the installation is completed it is necessary to flash the system. First

the water pipes are flashed, then the dripper lines are attached to the start connectors and the valve is open again. When the dripper lines are flashed too then the system is ready for operation.

COST

The initial capital cost for a complete Family drip piping system unit without the Tank is US\$100–120 for a land area of around 500 m². The price of a plastic tank of 300–500 litres capacity is almost the same with the piping system. In the many cases where the farmers use their own self-made tanks the cost is less. Two system units at a cost of US\$200–240 may cover a land area of 1 000 m². In case of the need of a water supply small pump for a group of farmers the extra cost is divided by the number of users (Table 15.1).

TABLE 15.1 - Useful data on common seasonal crops in the open (all values approximate)

Crop	Planting (transplant.)	Growing Period (days)	Harvest	Plant. Spacing (cm)		No. of plants for 100 m ²	Minimum No. of irrigations
				Along rows	Between rows		
Beans (trell., non-trell.)	Feb.–Mar. & Aug.	75–90	May–Nov. average	15–22 (5–10)	90 (45–60)	500–700 2 800	60
Cabbage	Aug.–Apr.	120–140	Year around	30–45	45–75	300–700	20
Celery	May–Oct.		Aug.–May	25–30	30–45		25
Cucumbers	Mar.–May Aug.–Sep.	105–130	May–Aug. Oct.–Nov.	30–50	130–160	120–240	55
Eggplants	Apr.–May	125–140	Jun.–Dec.	60–75	90	150	65
Lettuce	Sep.–May	70–90	Year around	15–30	30–45	750–2 200	20
Onions green	Sep.–Feb.	70	Nov.–May	5	15		15
Peppers	Apr.–May	120–180	Jul.–Nov.	45–60	75	200–300	60
Squashes	Mar.–Sep.	90–120	May–Nov.	60	120–140	100–140	50
Tomatoes (trellised)	Mar.–Sep.	135–190	Jun.–Dec.	45–60	90–150	180–250	65
Tomatoes (non-trell.)	Mar.–Sep.	135–180	Jun.–Dec.	60–75	150	100	65
Watermelons	Mar.–May	90–120	Jun.–Sep.	50–75	180–240	60–90	50

Note:

The growing seasons and periods of vegetables and annual field crops vary according to the local climatic conditions. In general the growing period of most of the seasonal crops is from 90 days to 170 days. The above indicative figures cover most of the arid and semi-arid regions of the N. Hemisphere.

This cost is significantly lower than the cost for a conventional high-level management drip irrigation system with the same coverage. In conventional sophisticated systems the Control Head accounts from 30 percent to 45 percent the total initial capital cost, whilst in Family drip systems there is no need for such investment and the Control Head comprises only of a valve 1 inch and a line filter of same size. At this total cost the Family Drip Systems can be classified as Low-cost irrigation systems.

ADVANTAGES

The price is very low, it is easily installed and operated and has all the advantages of drip irrigation, when correctly use and maintained. Fertigation can be applied through the system by diluting the soluble fertilizers in the tank of the system. The expenses of maintenance and the total cost of irrigation are reduced significantly.

There is no energy consumption. The pressure required for the system operation is very low (1–2 m head of water) as in gravity systems. In conventional drip installations the initial pressure at the Control Head is 3.0–3.5 Bars.

DISADVANTAGES

The lack of training and knowledge among the farmers on the agronomic aspects create negative results. The simplicity of the system in many cases turns into a negative factor as illiterate farmers in many countries do not maintain the dripper lines and the system's life is shortened to one or two seasons only.

EXAMPLE DESIGNS – Family drip systems in tomatoes (trellised)

Area and crop

The plot dimensions are 20 x 25 m (500 m²) planted in the open with tomatoes in rows 1.50 m apart and spaced along the rows 0.60 m. The plot is divided along into two parts, each one having 13 rows 12.5 m long. There are 21 plants per row. So there are 273 plants in every part, i.e. 546 plants in the whole plot and 26 plant rows. Planting is planned to be done in late July/early August and the growing period to be extended up to early next year 140 days approx.). Irrigation stops in late November, but harvesting continues until February.

Soil and water

Medium texture soil with permeability around 12 mm/h and relatively good water holding capacity. The source of water is a nearby shallow hand-dug well equipped with a small pumping unit; it is of good quality but with low impurities content. Filling of the system's tank is done directly from the well with the use of a PE hose.

Crop water requirements and irrigation schedule

The total irrigation requirements of the tomatoes are around 650 mm. The calculation is made following the FAO methodologies. The irrigation scheduling in this system is not arranged at a fixed moisture depletion of the available soil moisture, but at fixed interval of one day, two and three days. So irrigation takes place frequently and the dose varies according to the stage of growth of the crop. At the last, the harvest stage, the irrigation depends on the effective rainfall and the price of the tomatoes.

In this example design the crop is planted in mid summer at the highest Eto values. It is an extreme case as example, however very common in practice. As already mentioned above, *"The frequency of irrigation normally may be from 2–5 days with an average water dosage of 0.5–1 litre/day/plant at the first stage of growth. During the yield formation the dosage increases to meet the requirements of 1–2 litres/day/plant. Later the daily needs increase up to 3–6 litres/day/plant and at late season, sometimes, 5–7 litres/day/plant. Daily applications are needed."*

In the example case the water demand is very high in the early stages of the crop, although the crop ground cover is limited and increases as the crop is entering the mid and late season stages. (During the crop development and the mid-season stages and the kc value is 1.0, whilst in the early stages is 0.45–0.75. The systems application efficiency is 90 percent. In this example the following irrigation program can be used as a guideline (Table 15.2 and Figure 15.5):

TABLE 15.2 - The irrigation program of the case example

Growing period (stages)	Irrigation demand (mm)	Interval (days)	Dose litres/plant	Irrigation dose (m ³)	Number of irrigations	Total water applied (m ³) per 500 m ²
30 Jul.–15 Aug.	90	1	5.5	3.0	15	45
16 Aug.–10 Sep.	155	1	5.5	3.0	25	75
11 Sep.–10 Oct.	155	2	9	5.170	15	76
11 Oct.–15 Dec.	210	3	8	4.722	22	104
16 Dec.–15 Jan.	50	Effective rainfall equivalent to ET _c				25
TOTAL	660	-	-	-	77	326

FIGURE 15.5 - The FDS system layout.

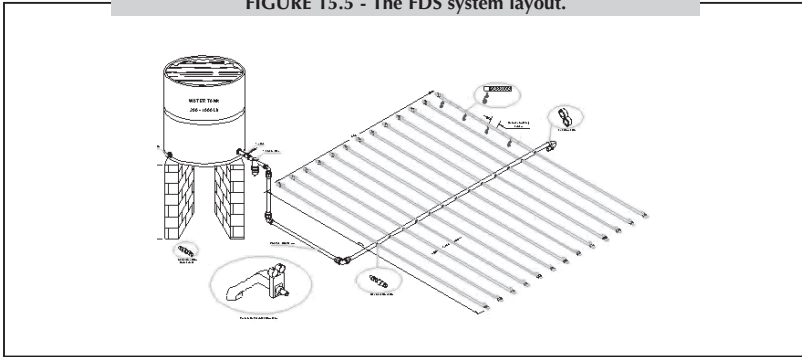

The layout of the system (description and characteristics), performance and hydraulics

- Area covered: 0.5 ha (average) (Plot dimensions 25m x 20 m).
- Type of Systems: Low-pressure, drip irrigation, solid systems installed at fixed seasonal positions.
- System layout: The 25 mm LDPE water pipeline crosses the area along the 20 m dimension with dripper lines one per row of plants fitted perpendicular on both sides.
- System's Component parts: a) Water tank (200 l), b) 1 inch control valve, c) 1 inch Filter, d) 25 mm LDPE main Pipelines, e) 8 mm Drip lines.
- System flow and pressure: 1 100 l/h at 1.5 m head approximately.
- Number of drip lines: 40
- Length of Dripper lines: 12 m
- Total length of dripper lines: 480 m
- Dripper discharge: 0.5–0.65 l/h at 1 m head and 0.65–0.80 l/h at 2 m head.
- Dripper spacing along the line: 30 cm
- Spacing between the lines: 1.5 m
- Total number of drippers: 1 600
- Entire area irrigated simultaneously.
- Number of shifts to fulfil one irrigation: 1 shift

Area covered (irrigated) depends on the kind of crop and especially the crop planting spacing. There are various layouts of the system depending on the size and the shape of the field. The drippers' frequent short spacing along the line ensures a continuous wetted strip along the plants rows, as in furrows.

Hydraulics of the system

The pressure required for the normal operation of the dripper lines is 1–1.5 m head of water. The loss of head due to friction in the 25 mm LDPE main

pipelines with 1.1 m/h flow is around 6 percent for pipes without outlets and 2.25 percent when water is distributed en route. So, the layout of the system and especially of the main lines should be the one that keeps these losses of head to the minimum. The placement of the water tank in the middle of the plot or next to it, is recommended. Sometimes the farmers arrange the tank at a higher position to compensate for these losses (Table 15.3).

TABLE 15.3 - List of equipment for system installation (Low-cost family drip irrigation system)

Item	Description	Quantity	Cost US\$
1.	LDPE pipe 25 mm	45 m	
2.	PP QR elbow 25 mm x 1 in (F)	1 pc	
3.	PP QR elbow 25 mm	1 pc	
4.	PP barbed start connector 8 mm	45 pcs	
5.	PP barbed start connector 8 mm blind	10 pcs	
6.	Plastic shut off valve 1 in (F)	1 pc	
7.	Plastic screen filter 1 in (M) 120 mesh	1 pc	
8.	Plastic tank outlet 1 in (M)	1 pc	
9.	LPDE drip line 8 mm with built-in point source drippers at 30 cm frequent intervals	500 m	
TOTAL COST			100

Note:

The cost for the tank is not included.

VARIOUS AMIT SYSTEMS CONFIGURATION (AFTER IDE)

FIGURE 15.6 - Drum kit using a 16 mm sub-main five 12 mm laterals with spaghetti micro-tubes in 120 m² area.

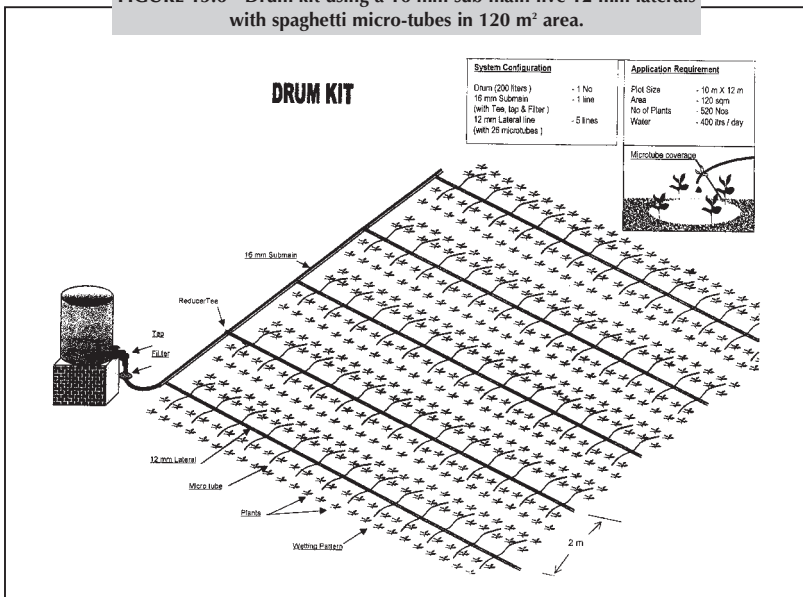

FIGURE 15.7 - System with dripper lines using standard sized holes as dripper emitters covered with plastic sleeves to control water discharge.

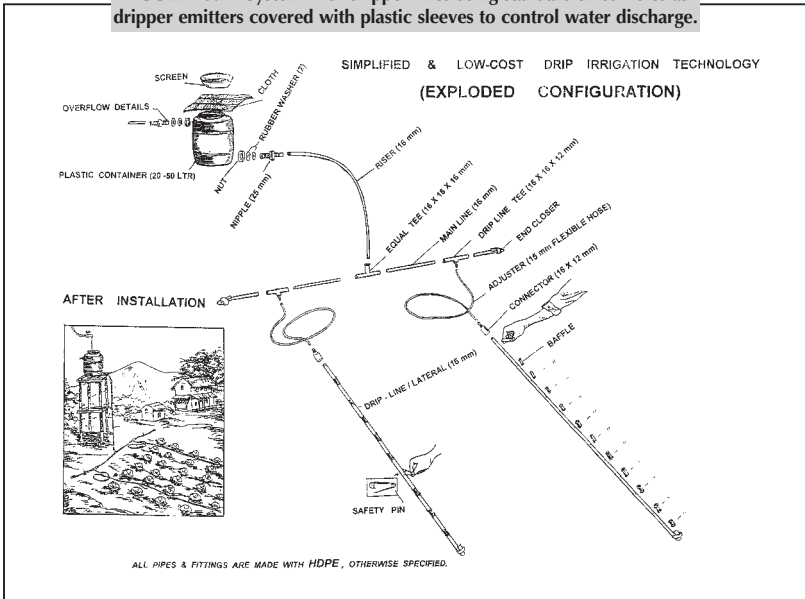

FIGURE 15.8 - Microsprinkler kit in 250 m².

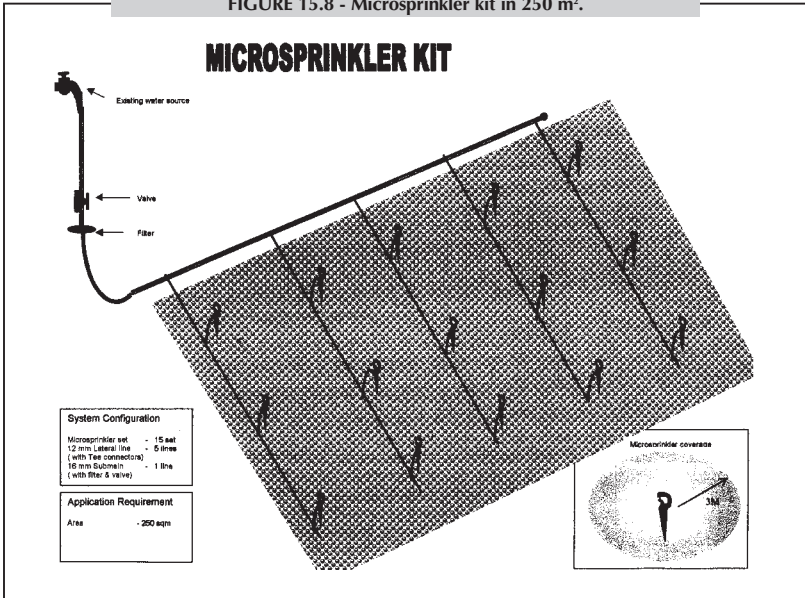

FIGURE 15.9 - Shiftable drifter lines system.

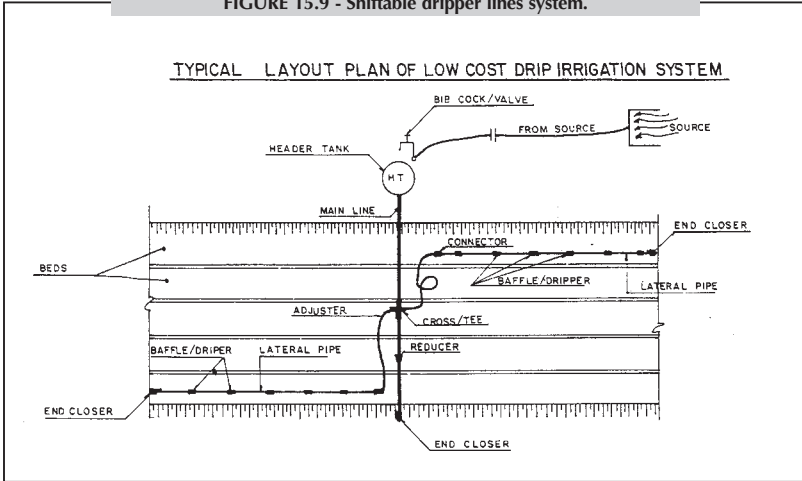

FIGURE 15.10 - Pitcher irrigation.

