

Chapter 6

Surface drainage systems

As was discussed in Chapter 3, a surface drainage system always has two components: (1) land forming, which is bedding, land grading, or land planing, and (2) the construction of field and collector drains. The three types of land forming are discussed first, followed by the design and construction of open drains.

LAND FORMING

Bedding

Design considerations

To ensure good drainage in a bedding system, the beds should not be more than 10 m wide. Further, the width of the beds is governed by the following:

- The kind of crops to be grown: Field crops require narrower beds than permanent pasture or hay crops do.
- Farming operations on beds: Ploughing, planting, and cultivating should fit the width of a bed. Bed width should be a multiple of the effective width of farm equipment.
- Soil characteristics: Soils with low infiltration and low hydraulic conductivity require narrower beds than soils with better characteristics.

Construction

Figure 38 shows how a bedding system is constructed. It often takes several years of ploughing to obtain an adequate bedding system. During the first ploughing, care should be taken to make beds of uniform width throughout the field and to have the field drains running in the direction of the greatest slope. Any obstructions or low points in the field drains should be eliminated because they will cause standing water and loss of crops. The collector drain should be laid out in the direction of the lesser field slope, and should be properly graded towards the main drainage system.

Land grading and land planing

When grading land for surface drainage, the slope does not need to be made uniform, as for irrigation; a non-uniform slope will suffice (Figure 39).

FIGURE 38
Construction of a bedding system

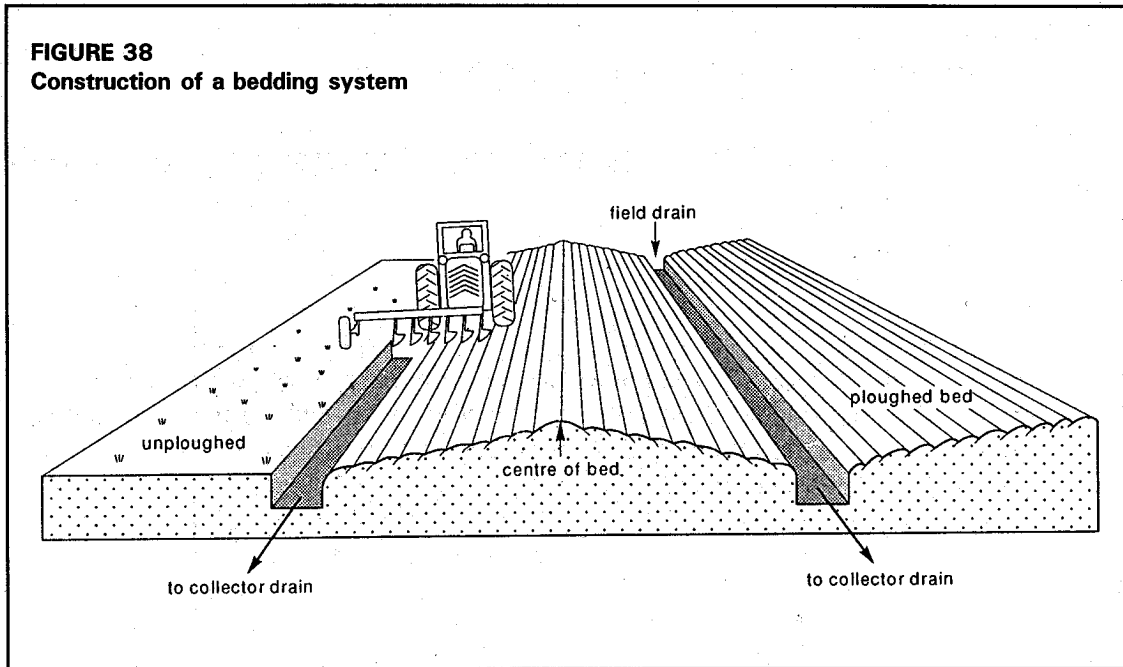
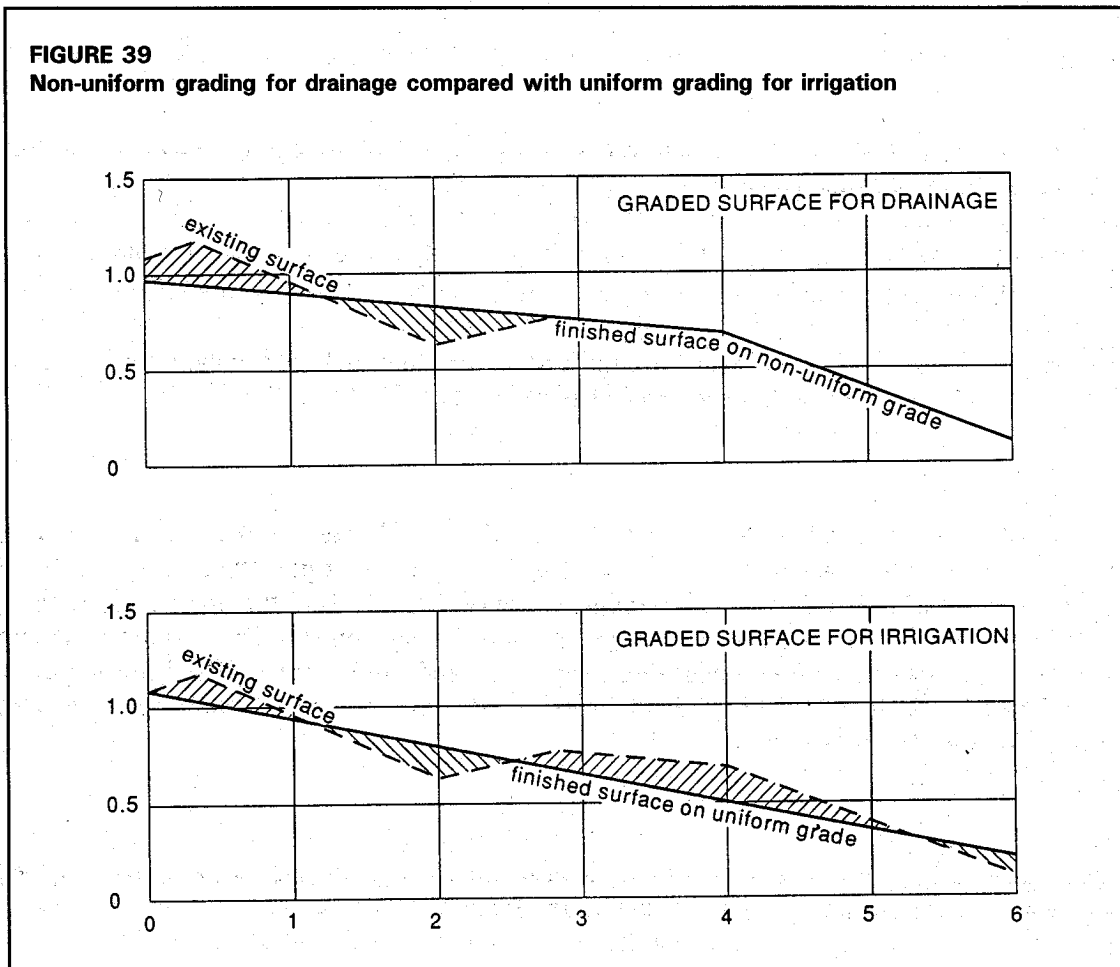
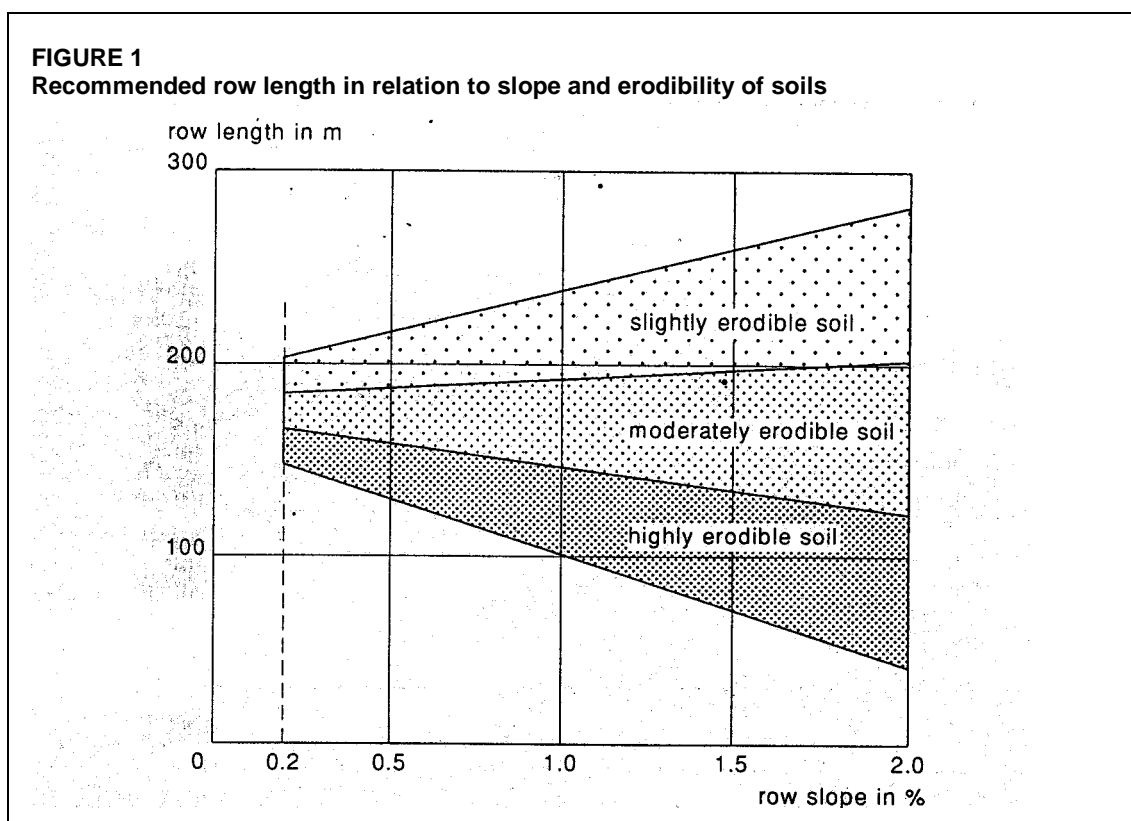

FIGURE 39
Non-uniform grading for drainage compared with uniform grading for irrigation





In addition, the types of crop and how they will be grown have to be considered. Crops like maize, potatoes, and sugar cane are grown in rows with small furrows in between. For such crops, the length of the rows and the slopes of the field must be selected so as to avoid erosion and overtopping of the small furrows. To prevent erosion, it is recommended that the flow velocities in the furrows should not exceed 0.5 m/s. In highly erodible soils, the row length is limited to about 150 m. Slightly erodible soils allow longer rows, up to 300 m. Figure 40 shows recommended lengths and slopes of rows (and the small field drains) in relation to soil erodibility. The direction of the rows and furrows need not necessarily be at right angles to the slope, but can be selected in any way that meets the above recommendations.

Small grains and hay crops are grown by broadcast sowing or in rows, but on an even surface (i.e. no furrows). For such crops, surface drainage takes place by sheet flow. This flow is always in the direction of the maximum slope. With sheet flow, the flow resistance is much higher than in small furrows, and the flow velocity on the same land slope is less. Even after careful land grading and smoothing, however, sheet flow always has a tendency to concentrate in shallow depressions, and gullies are easily formed (Figure 41). With the transport duration for low flow velocities in mind, it is recommended that the field length in the flow direction be limited to 200 m or less.

For wet-land rice and other crops grown in basins, the surface is levelled by earthmoving machinery (large basins) or with simple farm implements (Figure 42). Levelled fields are surrounded by field bunds. Any excess water from basins is usually drained through an overflow in the field bunds that spills the water directly into a field drain.

FIGURE 41
Sheet flow will easily result in erosion



FIGURE 42
Land levelling: final smoothing is done during the first irrigation

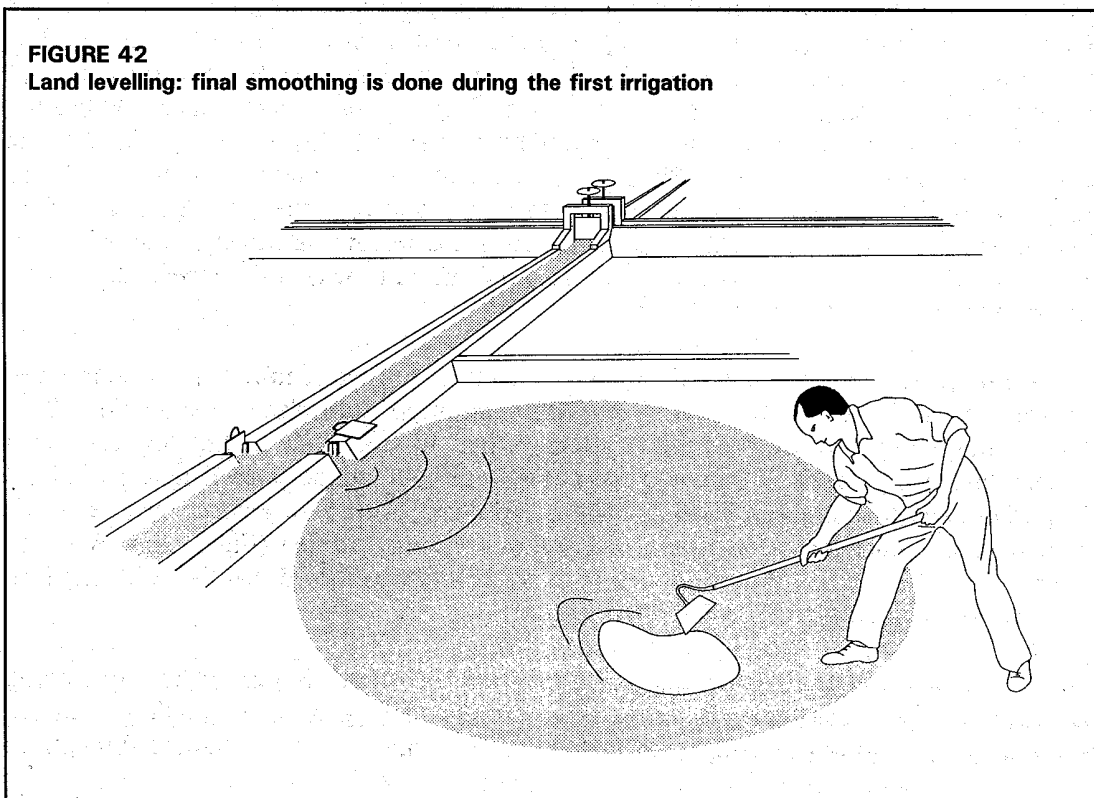

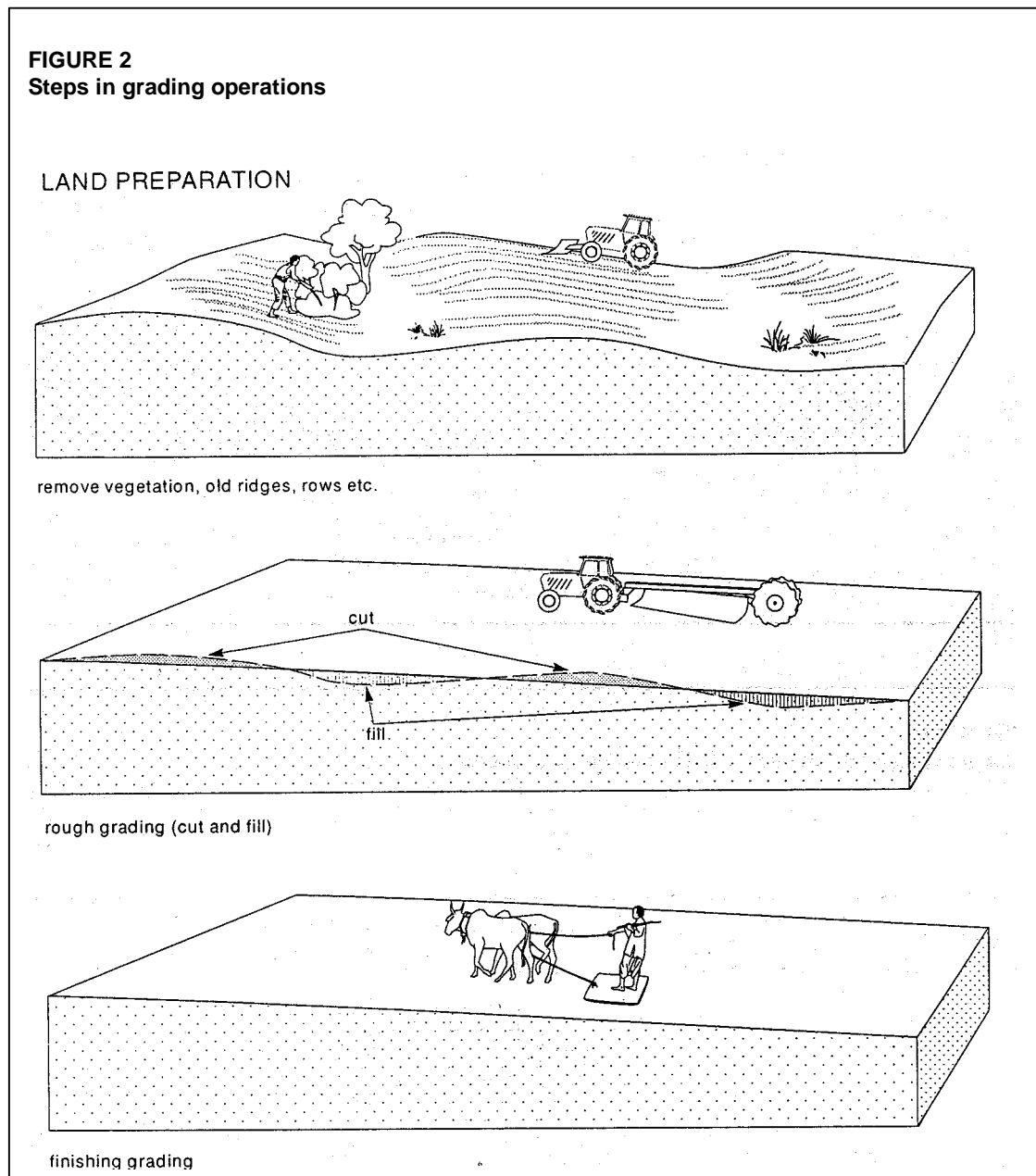

Construction

Land grading can be done by the farmers, although normal farm equipment, even if mechanized, can handle small-scale grading operations or the maintenance of already established grades. Large-scale land grading is done by contractors with conventional earthmoving equipment or with laser-guided motorized graders.

Grading operations involve a number of steps (Figure 43). The first step is to prepare the site. If the land has already been cleared, the work mainly involves removing or destroying vegetation and other obstacles, and levelling ridges or rows. This can normally be done with farm equipment. The surface should be dry, firm, and well-pulverized to enable the equipment to operate efficiently.

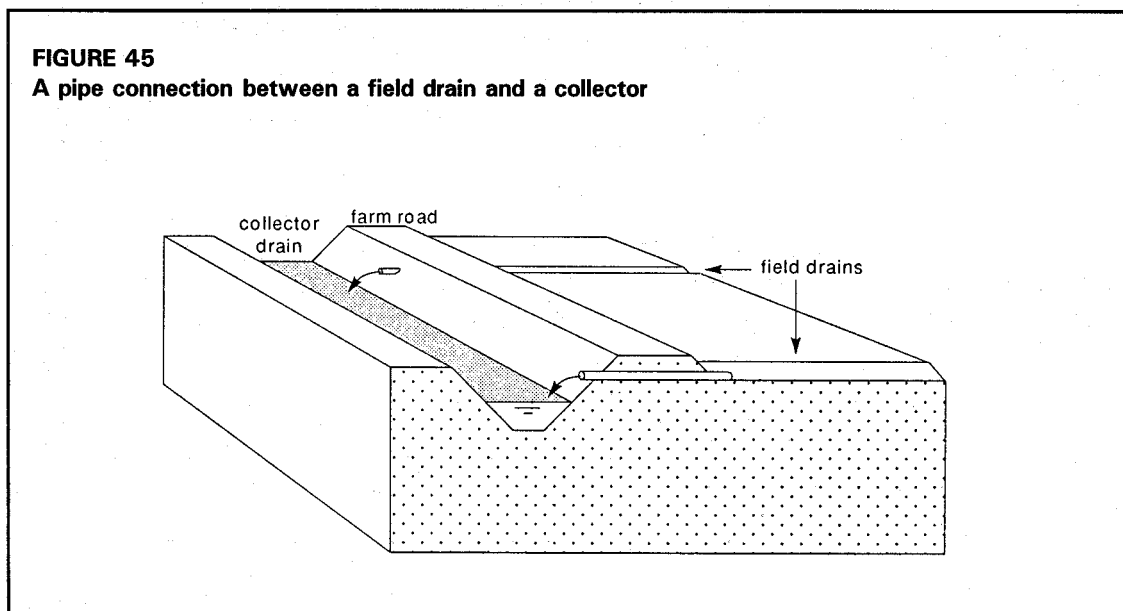
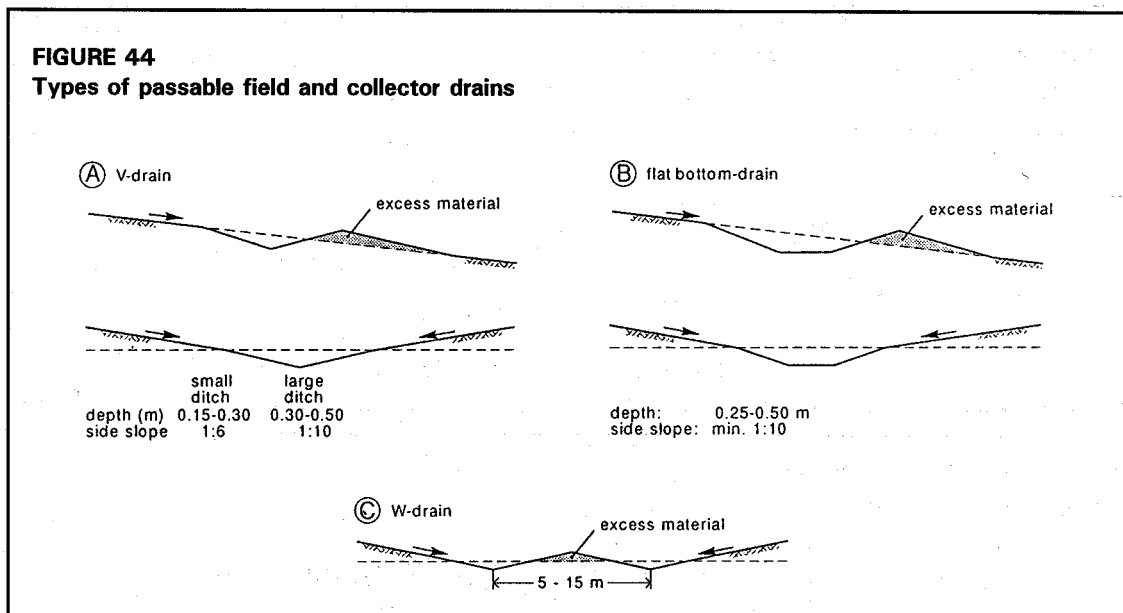

The second step is rough grading. This can be done with various types of equipment (e.g. dozers, motor graders, scrapers). The choice will depend on the soil conditions, the amount of earthwork needed, the time and equipment available, the size of the fields to be graded as one unit, and local experience.

The third step is the finished grading. On small fields, drags, harrows, and floats can be used. These implements can be pulled by a farm tractor or by animal traction. On larger fields, a land plane (a bottomless scraper) pulled by a farm tractor is used. For the final smoothing, several passes are usually made at angles to one another.

When extensive grading is done with heavy equipment, it is likely to cause the soil to become compacted. This compaction should be relieved to eliminate differences in soil productivity. Various tillage tools can be used for this work (e.g. subsoilers, chisels, scarifiers, and rippers).

FIELD DRAINS

Design of surface drains

Field drains for a surface drainage system have a different shape from field drains for subsurface drainage. Those for surface drainage have to allow farm equipment to cross them and should be easy to maintain with manual labour or ordinary mowers. Surface runoff reaches the field drains by flow through row furrows or by sheet flow. In the transition zone between drain and field, flow velocities should not induce erosion.

Field drains are thus shallow and have flat side slopes. Simple field drains are V-shaped. Their dimensions are determined by the construction equipment, maintenance needs, and their "crossability" by farm equipment. Side slopes should not be steeper than 6 to 1. Nevertheless, long field drains under conditions of high rainfall intensities, especially where field runoff from both sides accumulates in the drain, may require a transport capacity greater than that of a simple V-shaped channel. Without increasing the drain depth too much, its capacity can be enlarged by constructing a flat bottom, thereby creating a shallow trapezoidal shape. Figures 44A and B give some recommended dimensions of V-shaped and trapezoidal drains.

A variation is the W-shaped field drain, which is applicable where a farm road has to run between the drains (Figure 44C). These drains are generally farmed through and their upper slopes may well be planted. All field drains should be graded towards the collector drain with grades between 0.1 and 0.3%.

Open collector drains collect water from field drains and transport it to the main drainage system. In contrast to the field drain, the cross-section of collector drains should be designed to meet the required discharge capacity. The hydraulic design is similar to the design of irrigation canals. (See Training Manual No. 7 *Canals*.)

Besides the discharge capacity, the design should take into consideration that, in some cases, surface runoff from adjacent fields also flows directly into the field drains, which then require a gentler side slope.

When designing the system, maintenance requirements must be considered. For example, if the collector drains are to be maintained by mowing, side slopes should not be steeper than 3 to 1.

Attention must also be given to the transition between the field drains and the collector drains, because differences in depth might cause erosion at those places. For low discharges, pipes are a suitable means of protecting the transition (Figure 45). For higher discharges, open drop structures are recommended.

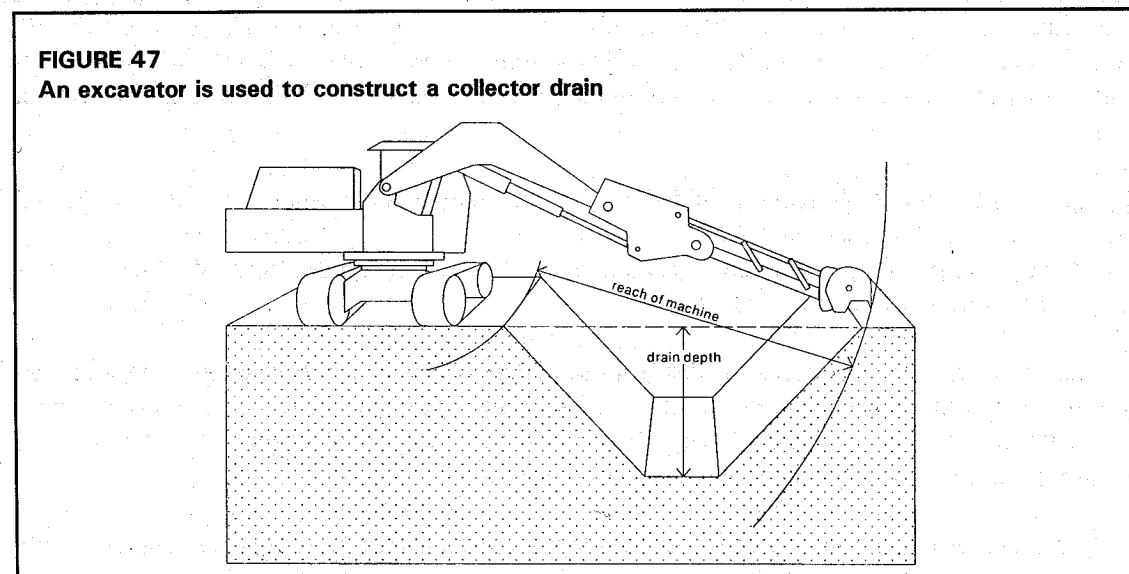
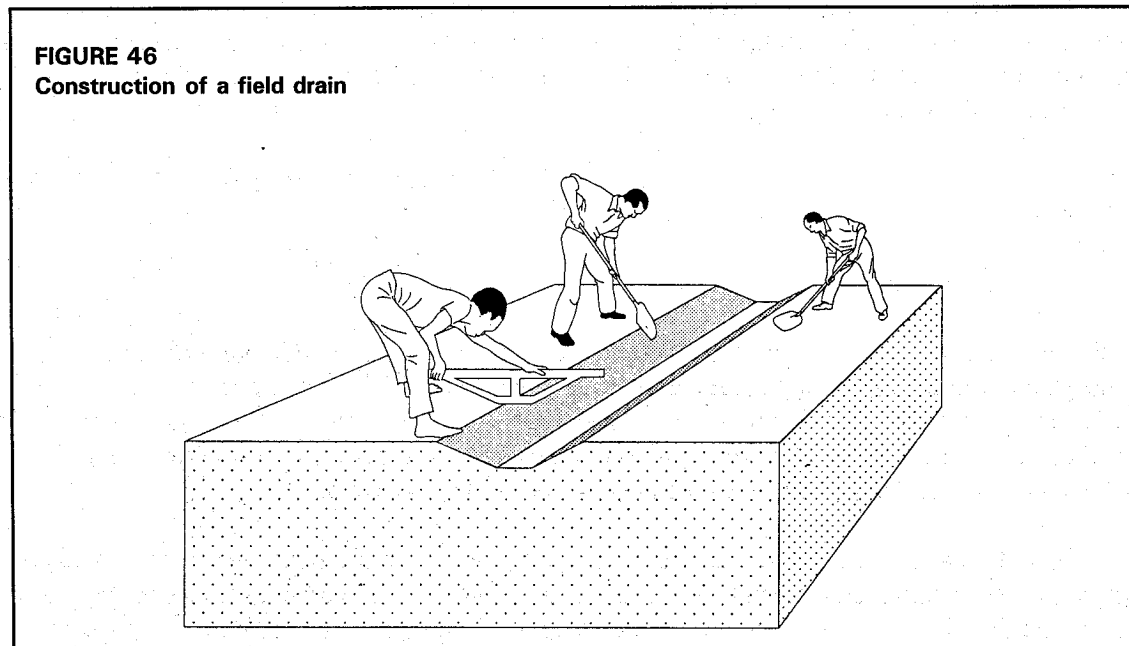

Construction of surface drains

Open surface drains can be constructed manually or mechanically (Figure 46). Care should be taken that the spoil from the drains does not block the inflow of runoff, but is deposited on the correct side of the ditch or is spread evenly over the adjacent fields.

Collector drains are usually constructed with different machinery than that used for field drains (i.e. excavators instead of land planes) (Figure 47). The soil is placed near the sides of the drain. Scrapers are needed when the excavated soil is to be transported some distance away.

Chapter 7

Subsurface drainage systems

TYPES OF SUBSURFACE DRAINAGE SYSTEMS

Subsurface drainage aims at controlling the water table – a control that may be achieved by tubewell drainage, open drains or subsurface drains (pipe drains or mole drains). Tubewell drainage and mole drainage are applied only in very specific conditions. Moreover, mole drainage is mainly aimed at a rapid removal of excess surface water, indirectly controlling the rise of the water table.

Open and pipe drains: The usual choice for subsurface drainage is therefore between open drains and pipe drains. This choice has to be made at two levels: for field drains and for collectors.

Open drains have the advantage that they can receive overland flow directly, but the disadvantages often outweigh the advantages. The main disadvantages are the loss of land, interference with the irrigation system, the splitting-up of the land into small parcels, which hampers mechanized farming operations, and a maintenance burden.

Tubewell drainage refers to the technique of controlling the water table and salinity in agricultural areas. It consists of pumping, from a series of wells, an amount of groundwater equal to the drainage requirement. The success of tubewell drainage depends on many factors, including the hydrological conditions of the area, the physical properties of the aquifer to be pumped and those of the overlying fine-textured layers.

Mole drainage: Heavy soils of low hydraulic conductivity (less than 0.01 m/day) often require very closely spaced drainage systems for satisfactory water control. With conventional pipe drains, the cost of such systems is usually uneconomic and hence alternative techniques are required. Surface drainage is one possibility; the other is mole drainage.

Mole drains are unlined circular soil channels which function like pipe drains. Their major advantage is their low cost and hence they can be installed economically at very close spacings. Their disadvantage is their restricted life but, providing benefit/cost ratios are favourable, a short life may be acceptable.

The success of a mole drainage system is dependent upon satisfactory water entry into the mole channel and upon the mole channel itself remaining stable and open for an acceptable period. Currently mole drainage systems are most commonly used for surface water control in perched water table situations; this is localized water tables above an impermeable layer.

FIGURE 48
Input factors for the calculation of drain spacings

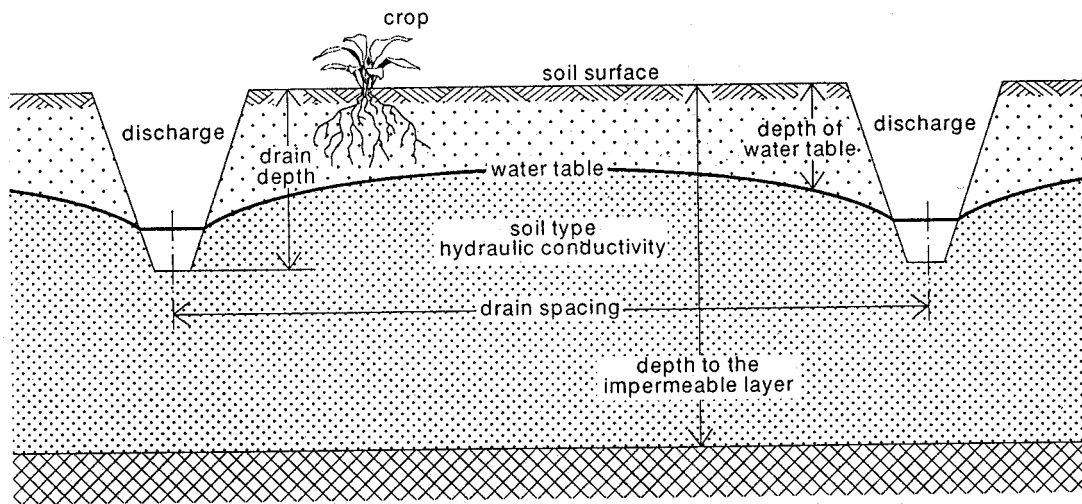
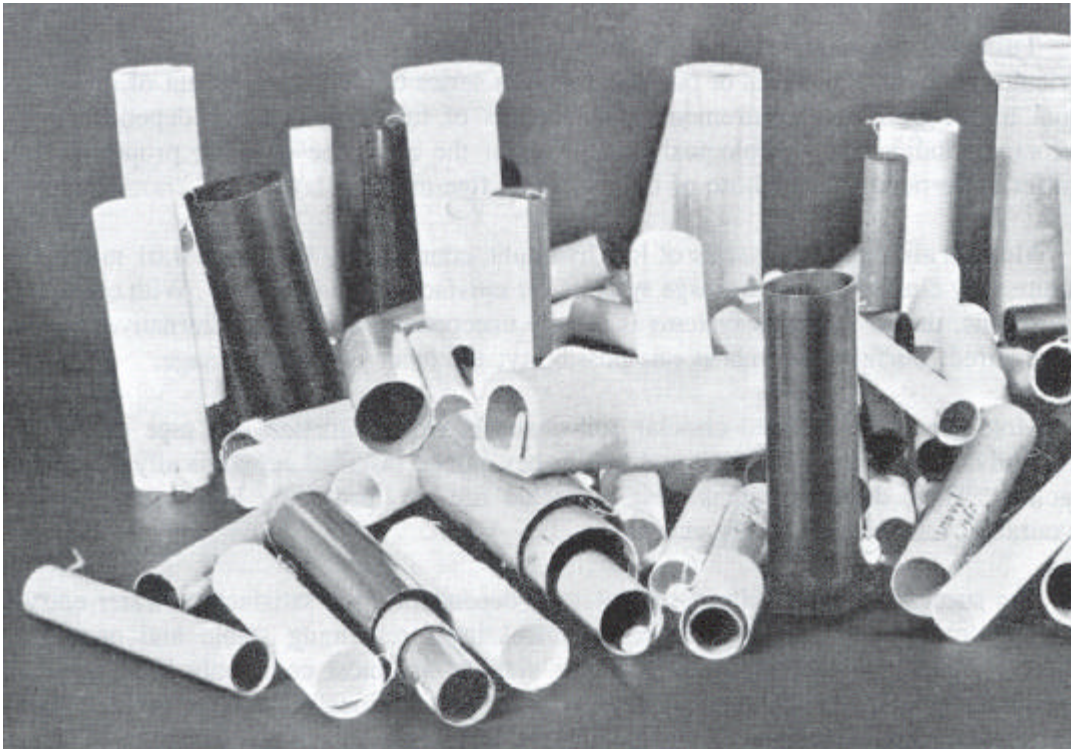

FIGURE 49
Different types of pipe drains



Mole drains are formed with a mole plough, which comprises a cylindrical foot attached to a narrow leg, followed by a slightly larger diameter cylindrical expander. The foot and expander form the drainage channel and the leg generates a slot with associated soil fissures which extends from the surface down into the channel. The mole plough is attached to the draw-bar of a tractor and the mole channel is installed at depths between 0.4 and 0.7 m. Common lengths of run vary from 20 to 100 m.

DESIGN OF SUBSURFACE DRAINAGE SYSTEMS

Depth and spacing of field drains

The depth and spacing of field drains are usually calculated with the help of drainage equations. The data needed for these calculations were discussed in Chapter 4 and include the agricultural requirements (depth of the water table and root depth), the soil characteristics (hydraulic conductivity and depth to the impermeable layer), and hydrological factors (drainage requirement) (Figure 48).

Calculated drain spacings normally show considerable variations due to the variations in input data. If so, the area should be divided into sub-areas or "blocks" of a convenient size (e.g. the area served by one collector). For each sub-area or block, a uniform and representative drain spacing can then be selected.

As an example, suppose that the calculated spacings in a project area vary between 18 and 85 m. Practical sets of standard spacings could then be: 20 - 25 - 30 - 40 - 50 - 60 - 80 m, or 20 - 30 - 45 - 60 - 80 m. It makes little sense to make the increments too small in view of the many inaccuracies and uncertainties in the entire process of calculating the spacings.

Pipes

The materials used in the manufacture of drain pipes are clay, concrete and (corrugated perforated) plastics (Figure 49). Important criteria for pipe quality and for selecting the most suitable type of pipe are the availability of raw materials, the resistance to mechanical and chemical damage, longevity and costs. The costs are the total costs for purchase, transport, handling and installation.

Envelopes

Sometimes, pipe drains are installed with an envelope. An envelope is the material placed around the pipe to perform one or more of the following functions:

- Filter function: to prevent or restrict soil particles from entering the pipe where they may settle and eventually clog the pipe.
- Hydraulic function: to constitute a medium of good permeability around the pipe and thus reduce entrance resistance.
- Bedding function: to provide all-round support to the pipe in order to prevent damage due to the soil load. Note that large-diameter plastic pipes are embedded in gravel especially for this purpose.

A wide variety of materials are used as envelopes for drain pipes, ranging from organic and mineral materials, to synthetic materials and mineral fibres. Organic material is mostly fibrous, and includes peat, coconut fibre and various organic waste products like straw, chaff, heather, and sawdust. Mineral materials are mostly used in a granular form; they may be gravel, slag of various kinds (industrial waste products), or fired clay granules. Synthetic materials may be in a granular form (e.g. polystyrene) or in a fibrous form (e.g. nylon, acryl and polypropylene). Glass fibre, glass wool and rock wool, which all are mineral fibres, are also used.

There are various ways of applying envelope materials. They can be applied in bulk, as thin sheets, or as more voluminous "mats". Bulk application is common for gravel, peat litter, various slags, and granules.

It is recommended to place the pipe in such a way that it is completely surrounded by the envelope material. In this way, the envelope material will fulfil its filter, hydraulic and bedding functions. Figure 50 shows a plastic pipe fully surrounded by gravel.

Thin sheets and mats are commonly used with corrugated perforated plastic pipe as a pre-wrapped envelope (Figure 51).

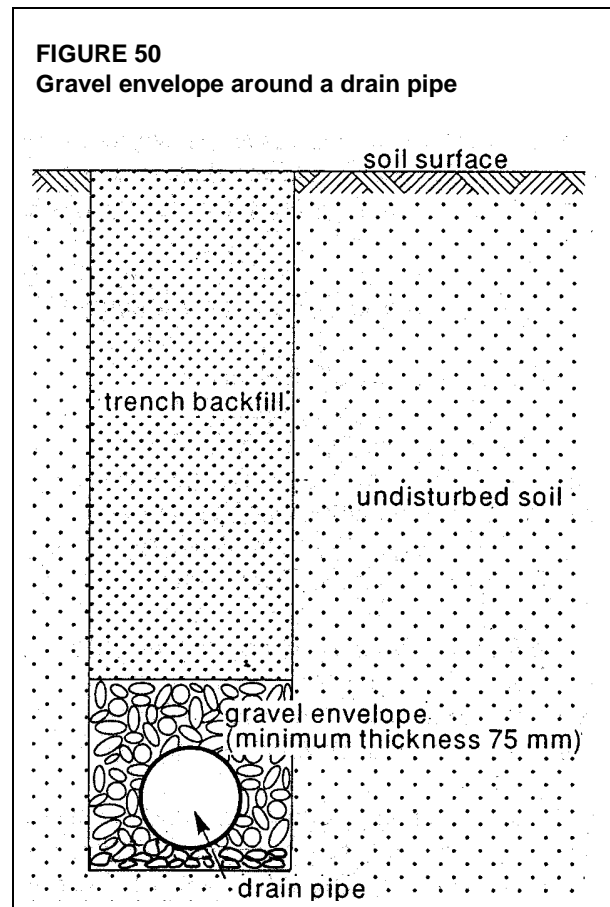

CONSTRUCTION OF PIPE DRAINAGE SYSTEMS

Construction methods

Pipe drainage systems are generally constructed by specialized contractors. They are selected after tenders have been called for, usually from a list of contractors drawn up by the authorities in a pre-qualification process. This type of construction work is beyond the scope of this manual. Only some matters directly related to the work at field level will be discussed.

The classical method of pipe installation consists of marking the alignments and levels, excavating the trenches by manual labour, placing the pipes and envelope material, and backfilling the trenches (Figure 52). Nowadays, field drains are installed by drainage machines, either trenchers or trenchless machines. Concrete collectors are often installed by excavators. In addition to the mechanics of installation, other important matters are the work planning, the working conditions, and supervision and inspection.

FIGURE 51
A pre-wrapped envelope

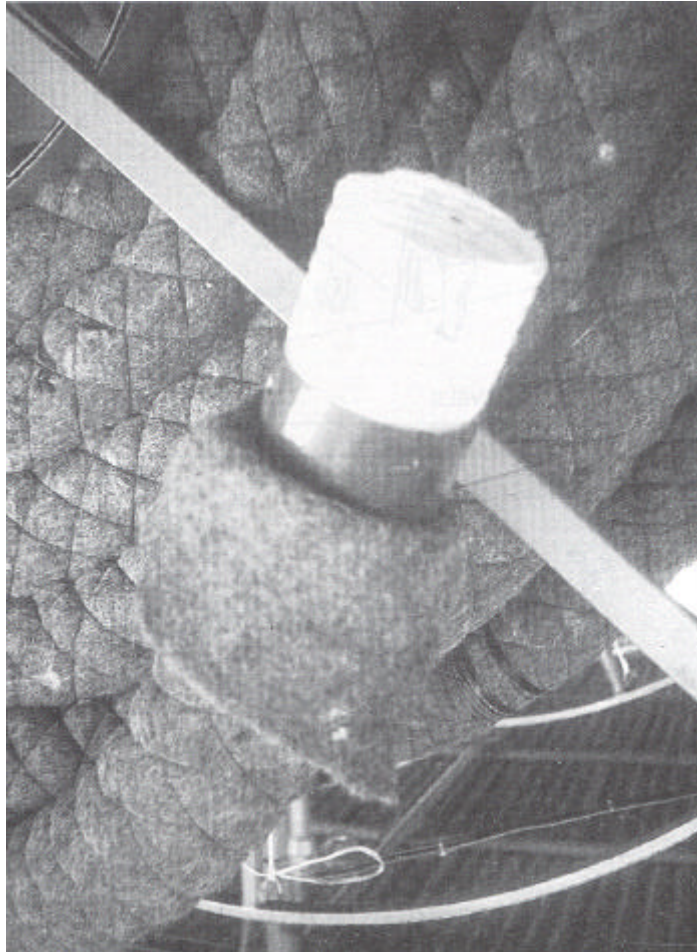

Alignment and levels

To mark alignments and levels, stakes are placed in the soil at both ends of a drain line, with the top of the stakes at a fixed height above the future trench bed. The slope of the drain line is thereby indicated. A row of boning rods is then placed in line (both vertically and horizontally) between the stakes, with an extension at the upstream end of the drain line, where the run of the drainage machine ends (Figure 53). The boning rods are thus in a line parallel to the trench bed. The driver of the drainage machine achieves grade control through sighting. The same principle can be applied when drains are installed manually.

Nowadays, most drainage machines have grade control by laser. An emitter, placed on a tripod near the edge of the field, establishes an adjustable reference plane over the field by means of a rotating laser beam (Figure 54). A receiver, mounted on the digging part of the drainage machine, picks up the signal. The control system of the machine continuously keeps a fixed mark in the laser plane. One position of the emitter can serve the installation of a fairly large number of drains.

FIGURE 52
Steps in the construction of a subsurface drainage system

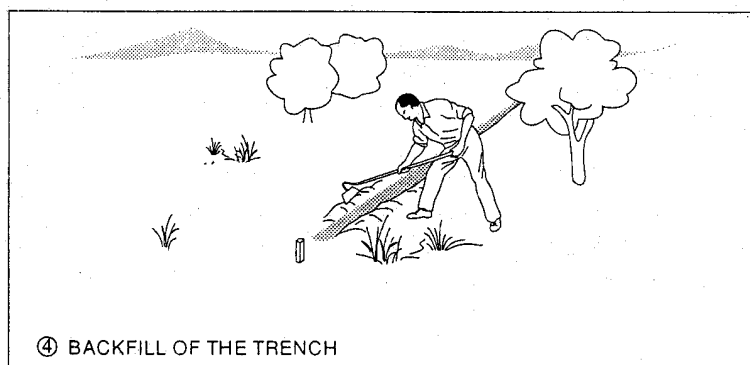
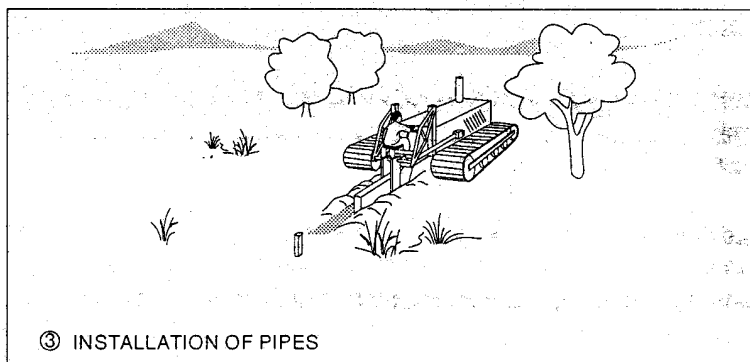
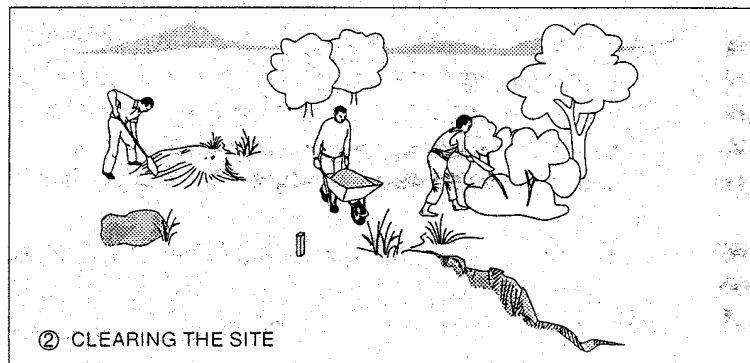
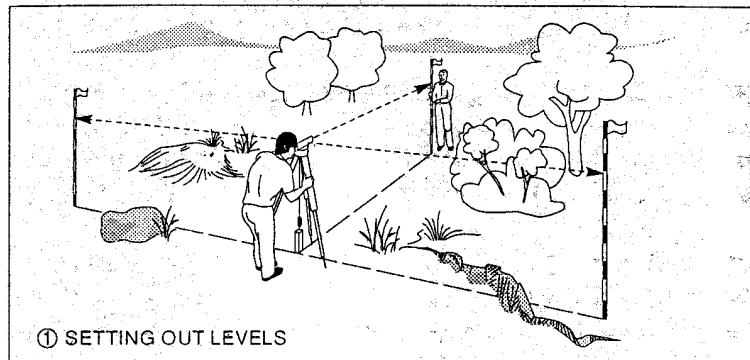

FIGURE 53
Setting out levels for drain pipe installation

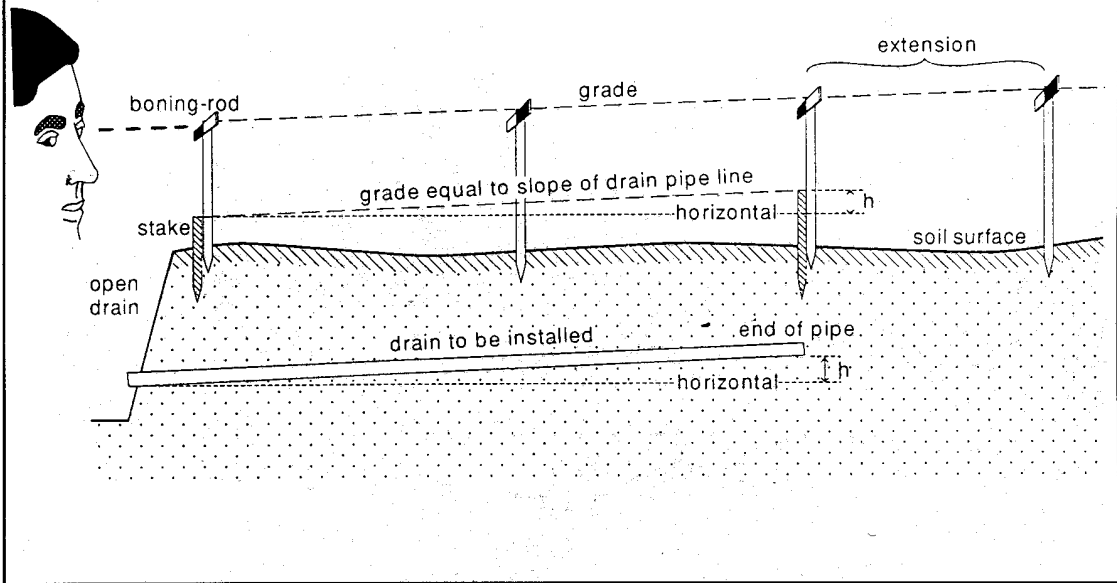

FIGURE 54
Grade control by laser for drain pipe installation

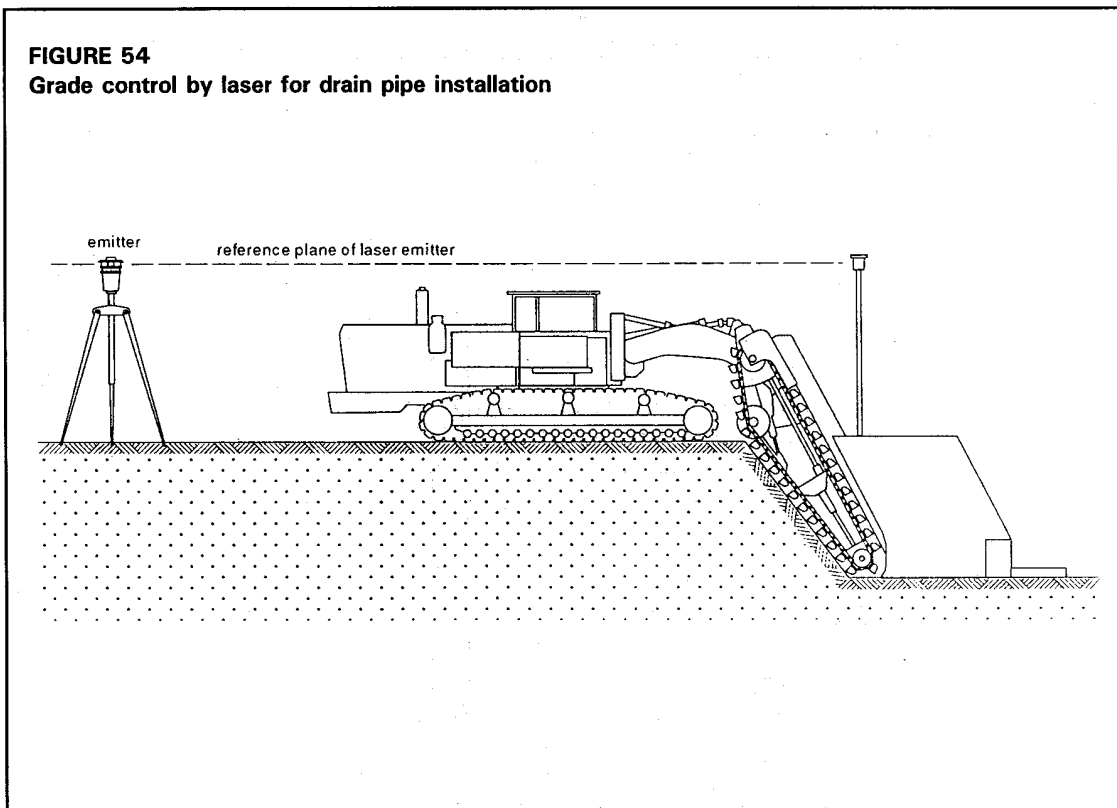
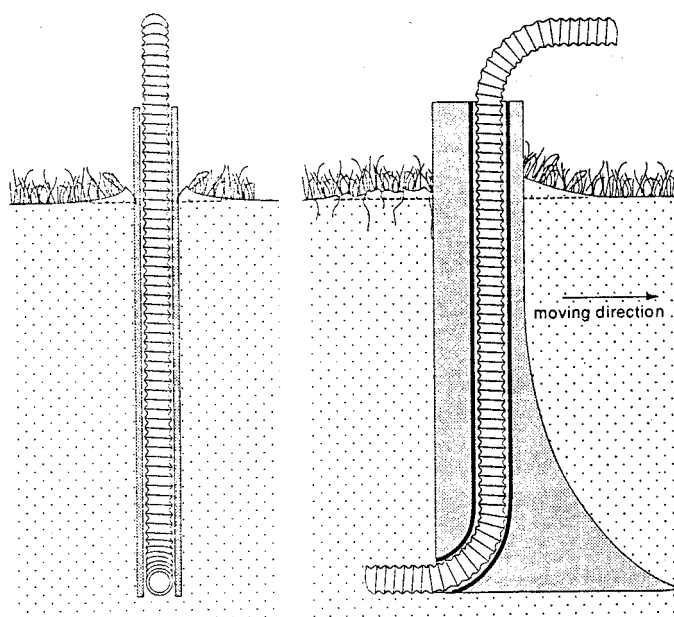
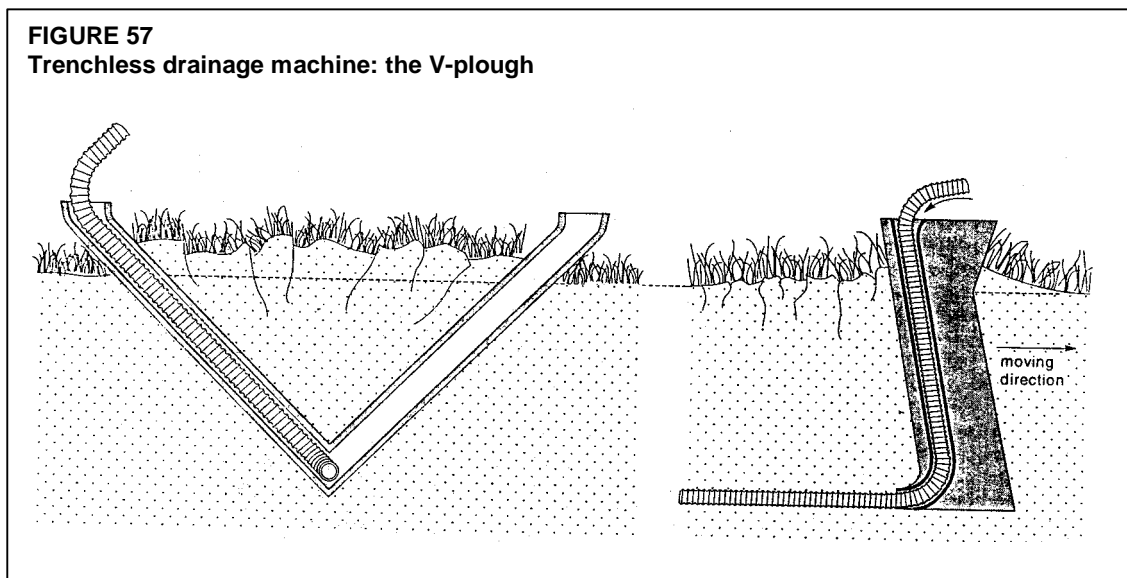

FIGURE 55
Trencher drainage machine



FIGURE 56
Trenchless drainage machine: the vertical plough





Machinery

The most common types of machines for installing field drains fall into two categories: trenchers and trenchless machines. Trenchers excavate a trench in which the pipe is laid, whereas trenchless machines merely lift the soil while the pipe is being installed.

Trenchers install the drains by excavating a trench and laying the pipe, including the envelope if applicable (Figure 55). The trench is backfilled afterwards by a tractor equipped with a dozer blade. Trenches should be backfilled the same day as they are dug to avoid a possible destabilization of soil under wet conditions (irrigation, rain, high water table). Running a tractor wheel over the backfilled trench, filling it up, and running over it again will take care of the required compaction. This procedure ensures that only the top part of the trench backfill is compacted, while the deeper part of the backfill retains a good permeability and a low entrance resistance.

The corrugated plastic pipe for small-diameter field drains is carried on the machine on a reel and is fed into the trench. Larger-diameter corrugated pipes (e.g. for collectors) are usually laid out and coupled in the field beforehand. The continuous tube is subsequently picked up and laid in the trench by the machine as it moves along. Clay tiles and concrete pipes move down a chute behind the digging chain.

Synthetic and organic envelopes are usually pre-wrapped around the corrugated pipe. For gravel envelopes, a hopper can be fitted into which the gravel is fed from a trailer moving alongside the drainage machine. For a complete gravel surround, two gravel hoppers can be fitted: one before the point where the pipe is fed in, and one after.

There are two types of trenchless drainage machines: the vertical plough (Figure 56) and the V-plough (Figure 57). The vertical plough acts as a subsoiler: the soil is lifted and large fissures and cracks are formed. The V-plough lifts a triangular "beam" of soil while the drain pipe is being installed. Backfilling is not needed, because no trench has been excavated. Nevertheless, when drains are installed with the vertical plough, the upper part of the



disturbed soil has to be compacted. A common procedure is that one track of the drainage machine runs over the drain line on its way back. In dry clay soil, this compaction may not be sufficient.

Corrugated plastic pipes are the only feasible pipes for trenchless machines. The V-plough can handle pipes with a maximum outside diameter, including the envelope, of 0.10 - 0.125 m. The vertical plough can handle much larger diameters. Although gravel envelopes would be possible with trenchless drainage, they are not recommended because of the risk of a clogged funnel and because of the difficulty of supplying gravel to a comparatively fast-moving machine. The only practical option is to use pre-wrapped envelopes.

The bottleneck for the speed of pipe installation is usually not the capacity of the drainage machine, but the organization and logistics connected with keeping the machine going. The preparation of the site (e.g. setting out, removing obstacles) is important, as is the operation and maintenance of the drainage machine (fuel supply, spare parts). In addition, the supply of

pipe and envelope material needs to be properly organized.

SUPERVISION AND INSPECTION

During the construction of the drainage system, the work should be regularly inspected and supervised (Figure 58). There are several reasons for this:

- to ensure that design specifications are complied with;
- to handle unforeseen conditions during installation;
- to check the quality of the structures and the materials used (pipes, envelope), which includes a site-check on possible damage during transport and handling;
- to ensure good workmanship, including the proper alignment of drain lines, which should be straight and according to the design slope, within an accepted tolerance (half the inside pipe diameter for field drains), and with proper joints;
- to see that the trenches are properly backfilled and compacted;
- to assess the need for any extra work or modifications, which implies that the supervisor should be a well-qualified person.

This inspection should cover both the total output (quantity control) and technical factors (quality control). Both types of inspection should be done regularly during execution because this enables any faults to be corrected immediately.