

FAO ANIMAL PRODUCTION AND HEALTH

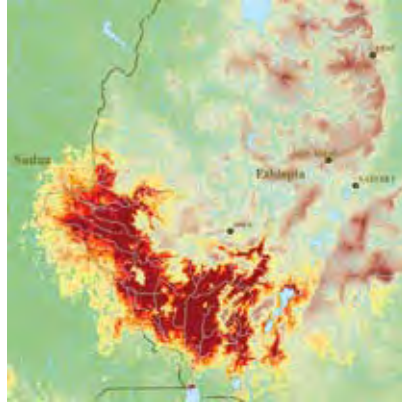

guidelines

COLLECTION OF
ENTOMOLOGICAL BASELINE
DATA FOR TSETSE
AREA-WIDE INTEGRATED PEST
MANAGEMENT PROGRAMMES



COLLECTION OF
ENTOMOLOGICAL BASELINE
DATA FOR TSETSE
AREA-WIDE INTEGRATED PEST
MANAGEMENT PROGRAMMES

Stephen G. A. Leak

Dejene Ejigu

Marc J. B. Vreysen

Joint FAO/IAEA Programme of Nuclear
Techniques in Food and Agriculture
Vienna, Austria

The designations employed and the presentation of material in this information product do not imply the expression of any opinion whatsoever on the part of the Food and Agriculture Organization of the United Nations (FAO) concerning the legal or development status of any country, territory, city or area or of its authorities, or concerning the delimitation of its frontiers or boundaries. The mention of specific companies or products of manufacturers, whether or not these have been patented, does not imply that these have been endorsed or recommended by FAO in preference to others of a similar nature that are not mentioned.

ISBN 978-92-5-106158-9

All rights reserved. Reproduction and dissemination of material in this information product for educational or other non-commercial purposes are authorized without any prior written permission from the copyright holders provided the source is fully acknowledged. Reproduction of material in this information product for resale or other commercial purposes is prohibited without written permission of the copyright holders.

Applications for such permission should be addressed to:

Chief

Electronic Publishing Policy and Support Branch

Communication Division

FAO

Viale delle Terme di Caracalla, 00153 Rome, Italy

or by e-mail to:

copyright@fao.org

Contents

Foreword	vii
SECTION 1	
Basic Biology and Anatomy of the Tsetse Fly	1
1.1. Introduction	1
1.2. External Anatomy	1
1.2.1. Cuticle	1
1.2.2. Mouthparts	4
1.2.3. Thorax	6
1.2.4. Legs	6
1.2.5. Wings	6
1.2.6. Abdomen	8
1.2.7. Genitalia	8
1.3. Internal Anatomy	9
1.3.1. Organs Associated with Feeding and Digestion	9
1.3.2. Reproductive System	10
1.4. Life Cycle	12
1.5. Identification of Tsetse Flies	14
1.5.1. Key for the Identification of Adults of the Species of <i>Glossina</i>	15
1.6. Glossary of Terms	39
1.7. Tsetse Distribution	40
SECTION 2	
Planning and Preparation of a Baseline Data Survey	47
2.1. Identification of a Potential Project Area	47
2.1.1. Selecting an Area	47
2.2. Objectives of the Survey	52
2.2.1. Subsequent Phases	53
2.2.2. Types of Survey	53
2.2.3. Population Dynamics and Behavioural Studies	54

2.3. Designing a Sampling Strategy	54
2.3.1. Design of a Survey Programme	54
2.3.2. General Principles	54
2.3.3. Pattern of Spatial Sampling	55
2.3.4. Pattern of Sampling in Time	55
2.3.5. Stratification and Stratified Sampling	56
2.3.6. Meteorological Data: What Climatic Data Should Be Recorded?	62
2.4. Preparatory Phase	63
2.4.1. Area Identification	63
2.4.2. Georeferencing	72
2.4.3. Defining the Limits of the Survey Area	80
2.4.4. Setting Up a Database	96
2.4.5. Sensitizing the Local Population	116
2.4.6. Management of Resources	117
SECTION 3	
Implementation of a Baseline Data Survey	123
3.1. Sampling Devices	123
3.1.1. Traps	123
3.1.2. Trap Manufacture: Materials and Construction	129
3.1.3. Interpretation of Trap Catches	138
3.1.4. Odour Attractants	140
3.1.5. Deployment of Traps	145
3.1.6. Maintaining the Survey Equipment	156
3.2. Entomological Procedures	158
3.2.1. Identification of Tsetse Species and Sex	159
3.2.2. Trap and Tsetse Distribution Maps	159
3.2.3. Estimation of Apparent Density	159
3.2.4. Blood Meal Analysis	162
3.2.5. Dissection	163
3.2.6. Population Dynamics and other Entomological Assessment	174
3.3. Genetic Analysis	175
3.3.1. Objectives of Genetic Analysis in the Context of AW-IPM Programmes	175
3.3.2. Principles of Genetic Analysis	176
3.3.3. New Possibilities: Geometric Morphometrics of Tsetse	176
3.3.4. Collection of Samples for Genetic Analysis	178

3.4. Reporting	178
3.5. Examples of Grid Based Tsetse Surveys	180
3.5.1. Togo	180
3.5.2. The Southern Rift Valley, Ethiopia	182
3.5.3. The Gambia	185
3.5.4. The Ghibe Valley, Ethiopia	187
3.6. Equipment and Materials Required	187
3.6.1. Materials/equipment	187
References	191
ANNEX 1 Links to web pages	199
ANNEX 2 Glossary	201
ANNEX 3 Acronyms	203
ANNEX 4 Suppliers	205

Foreword

The creation of tsetse-free zones using an area-wide integrated pest management (AW-IPM) approach, as outlined in the Pan African Tsetse and Trypanosomiasis Eradication Campaign (PATTEC) Plan of Action is a noble undertaking but also a very challenging one in view of the transboundary nature of the tsetse and trypanosomiasis problem. AW-IPM programmes, especially those that include a sterile insect technique (SIT) component are complex and management intensive (Vreysen et al. 2007) and are usually implemented in different phases. Before any operational suppression or eradication can be attempted in the target area, it is essential that accurate baseline data be collected in order to develop an appropriate intervention strategy. This document attempts to provide detailed guidelines for both senior technical staff involved in the planning of entomological surveys for AW-IPM programmes (section 2) and field workers who will be involved in the implementation of these surveys (section 1 and 3).

The term area-wide in AW-IPM refers to the target population (not the target area) and is defined as the integrated use of control tactics against an entire tsetse population within a delimited geographical area (Klassen 2005), i.e. total population management (Hendrichs et al. 2007). The target area could be quite large, as for example the area of the Southern Rift Valley of Ethiopia infested by *Glossina pallidipes* (25 000 km²) or quite small, such as the *Glossina palpalis gambiensis* infestation in the Niayes area, close to Dakar, Senegal (~ 1000 km²). The concept of AW-IPM differs from localized control or field-by-field management that has in the last decades been the more traditional way of dealing with the tsetse problem. Field-by-field management addresses only small fractions of a pest population at any given time, usually those that cause a current problem (e.g. an outbreak of disease). The goal of these two approaches is completely different and although both have merit, the choice as to which to use has many financial, managerial, and technical implications that have to be taken into consideration (Hendrichs et al. 2007).

Although comprehensive, the subject matter is not necessarily exhaustive in the level of detail given as there are already good sources of information on many topics, and appropriate references and links are given. In particular, the FAO training manuals for tsetse personnel (volume 1–5) are referred to as valuable sources of information. These guidelines will update some of the information found elsewhere (e.g. Cuisance 2000), as new research is constantly contributing to the improvement of survey methods (especially in the fields of odour attractants and development of new traps).

Whilst someone wishing to understand all aspects of tsetse survey work could read the manual from cover to cover, it is more likely that they will use it for reference, or for finding information on a particular activity as it arises. These guidelines therefore provide some background information for increased understanding as well as a more practical level of how to carry out a specific activity.

There are differences between theory and practice when considering how to plan a tsetse survey necessitated by the need to compromise between what is theoretically possible and what is practical within the financial and human resource constraints. For example, we know

that tsetse presence and absence can change over very small distances and they might be found in one place with suitable habitat but not in another, with apparently similar habitat. We also know that at very low densities, with traps of limited efficiency, trapping over a period of three days with a small number of traps may not detect those flies and a zero catch does not mean tsetse are absent. Theoretically we should trap in those situations with a higher number of traps for a longer period of time. Models have now been developed that make it possible to calculate the number of traps and the duration of trapping necessary to be able to determine presence within a given degree of probability, based upon the efficiency of the trapping device used, the particular species of tsetse in question, the season and the expected density of the flies. However, unless dealing with a relatively small area, it is unlikely that the required intensity of trapping would be possible.

The authors would like to thank the comments and contributions made by Dr. Robert Mangan, Dr. Philippe Solano (on genetics), and Mr. Micha Silver (on GIS). They also would like to thank the numerous field workers and colleagues who have provided feedback and useful comments on an earlier version of this manual.

Section 1

Basic Biology and Anatomy of the Tsetse Fly

1.1. INTRODUCTION

The objective of this section is to provide essential information for the subsequent two sections, which give guidelines for conducting baseline tsetse surveys, so that a field worker or planner will have the basic knowledge required to carry out tsetse survey and monitoring work. It is, therefore, not intended to be a comprehensive entomological textbook, and does assume a basic knowledge of biology, as this is expected to be a requirement of anyone employed in this type of work. This section is mostly written as a revision of the now out of print Volume 1 of the FAO training manual for tsetse control personnel (FAO 1982a) and its editor Dr. John Pollock and FAO are gratefully acknowledged as the source of that valuable contribution. Many of the figures used in this section are reproduced from the FAO training manual with permission from FAO and from two important text books, i.e. The African trypanosomiasis (Mulligan 1970) and The natural history of tsetse flies (Buxton 1955), and again acknowledgments are made for their reproduction here. In order to make the key as useful as possible many diagrams are incorporated from other sources in order to make identification of tsetse species as easy and certain as possible. The authors and publishers of these original drawings are also gratefully acknowledged.

1.2. EXTERNAL ANATOMY

Tsetse flies (**Figure 1.1**) belong to the Phylum Arthropoda, which means they have segmented bodies, and they are two-winged insects, which places them in the Order Diptera. Much of their anatomy is therefore similar to other insects and Diptera, or “flies”. In this section we shall concentrate on some of the features that distinguish them from other flies rather than describe all the general features of flies in detail. They have their own Family, Glossinidae, which has just one Genus, *Glossina*, with about 34 species and subspecies. The rules of scientific nomenclature are that the Genus and Species name should be written in italics or underlined and should always have a capital “G” for *Glossina* and a small letter for the species name, e.g. *Glossina austeni*.

1.2.1. Cuticle

All insects, including tsetse flies have a tough outer covering called the cuticle. This is made out of a protein called chitin and can be transparent, as when it covers the eyes, or darkened, although it is generally hard, it can be flexible where necessary; for example, where the wings join the body or at the joints of the mouthparts and legs. The chitin of the ventral

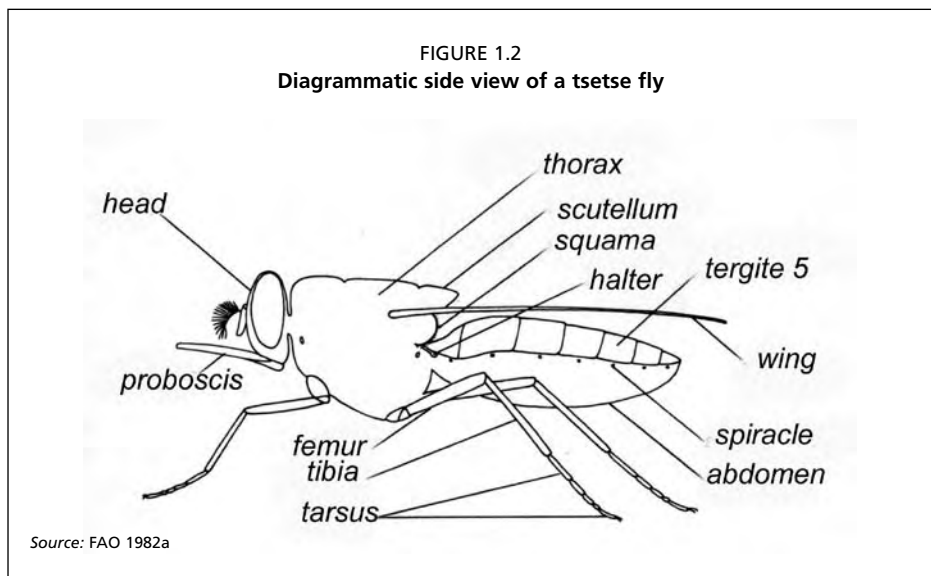
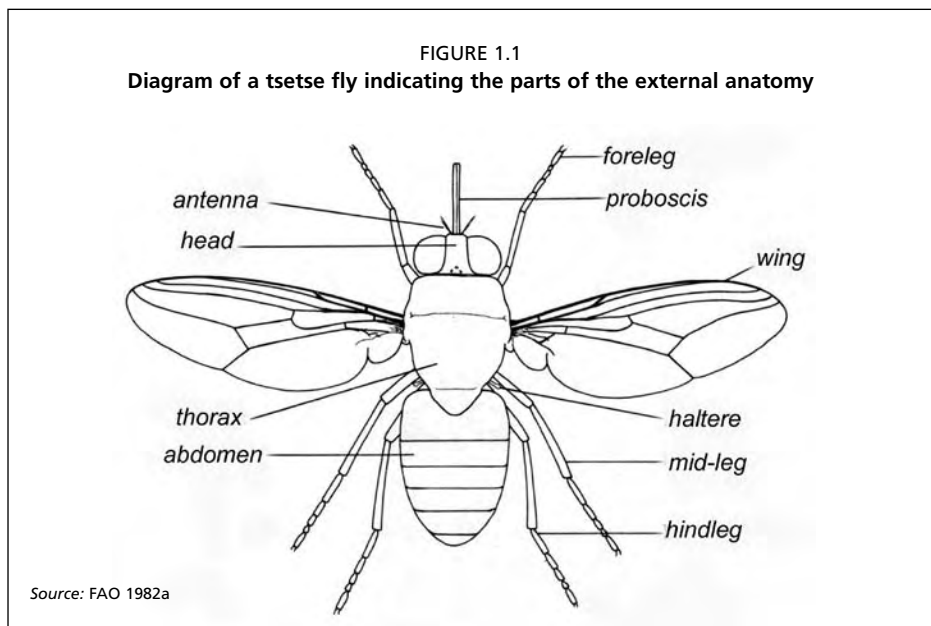

(underneath) surface of the tsetse abdomen is elastic so that it can expand to contain the blood meal after the fly has fed.

As with all insects, the tsetse fly (**Figure 1.2**) has three main segments; the head, thorax and abdomen. The wings and legs are attached to the greyish-brown coloured thorax.

The compound eyes (**Figure 1.3**) are comprised of thousands of small units called ommatidia; each ommatidium has a lens at the surface of the eye. Experimental observations suggest that the compound eye allows tsetse to see things at a distance of up to

FIGURE 1.3
Lateral view of the head of a female *Glossina pallidipes*



A. PARKER

FIGURE 1.4
Diagrammatic side view of the tsetse head

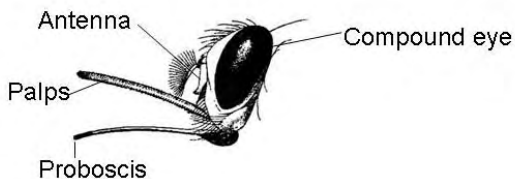

Source: Buxton 1955

130–140 metres, but they are best for detecting small movements at close range. In addition to the compound eye the fly has three simple eyes, called ocelli.

There are two antennae (**Figures 1.3, 1.4, and 1.5, right**) at the front of the head, each comprised of three segments. Attached to the upper side of the largest segment is a long thin structure with a row of branched hairs; this is called the arista. These characteristic antennae are important for species identification.

There are two sensory organs called sensory pits, containing sensory hairs (sensillae) on the third antennal segment; these sensory pits are important to the tsetse for detecting odours (e.g. attractants).

When the adult tsetse emerges from a puparium under the ground, it does this aided by a balloon-like structure called a ptilinum that comes out from the front of the head when

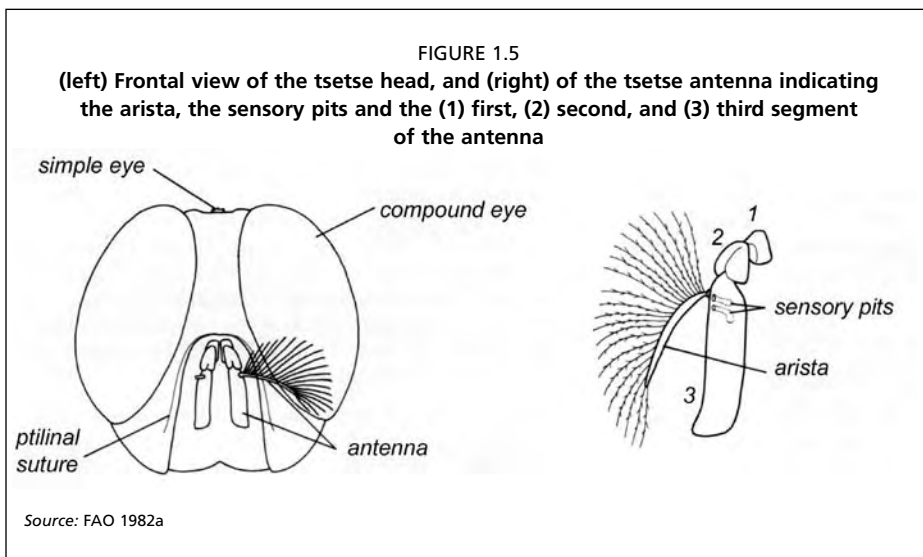

inflated. After emergence this ptilinum retracts back into the head and all that can be seen is the fold from which it retracts, termed the ptilinal suture (**Figure 1.5, left**). In a young, unfed fly, these structures are still soft and by squeezing the head gently it is possible to make the ptilinum come out from the head. This is useful in categorizing the age of a fly, a young fly which is unfed being termed a “teneral” fly.

1.2.2. Mouthparts

The tsetse mouthparts are also characteristic features that can be used to distinguish tsetse from other types of fly (**Figure 1.6**). The mouthparts are attached to the head by a bulb-like swelling at the end of the labium, called the thecal bulb (**Figure 1.7b**). This bulb contains muscles to manipulate the mouthparts. At rest, the mouthparts point forward (**Figure 1.7a**) and are protected by a pair of maxillary palps (**Figure 1.7c**). When the fly feeds, the mouthparts are lowered from the palps and point downwards (**Figure 1.7c**).

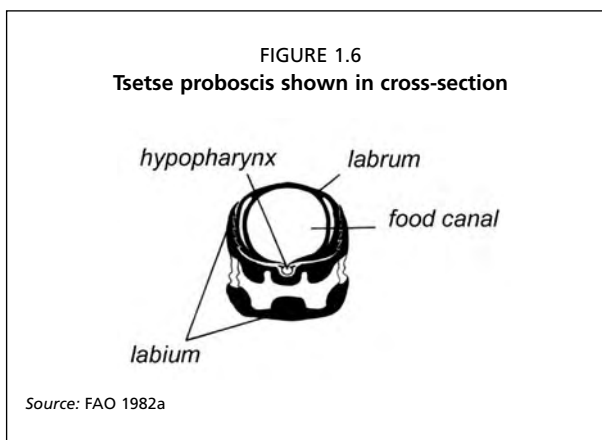
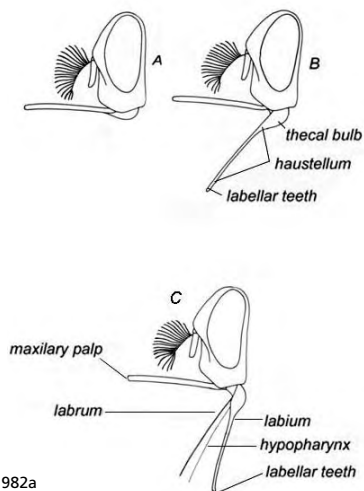
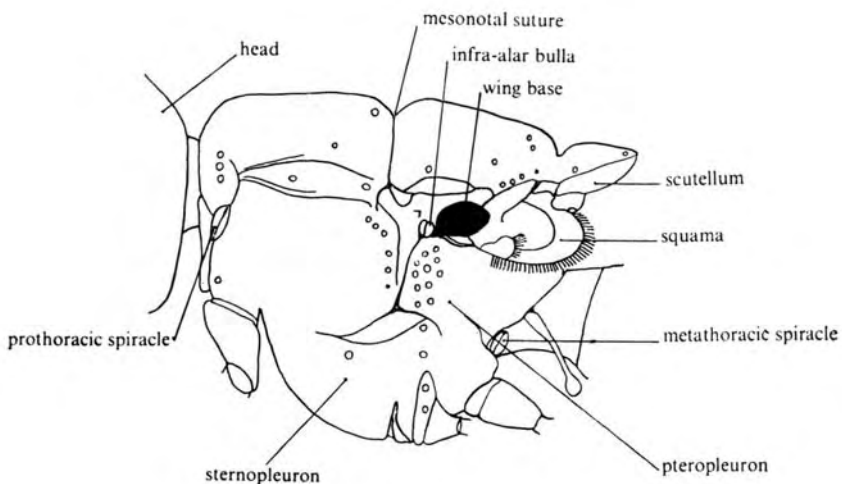

FIGURE 1.7
(a) Head and mouthparts when at rest, (b) head when mouthparts are lowered from the maxillary palps for feeding, and (c) components of the proboscis



Source: FAO 1982a

FIGURE 1.8
Diagram of the left side of the thorax of *Glossina palpalis*



Source: Buxton 1955

The tube for sucking blood is made up of two parts that are shaped like the gutter of a building and they fit closely one on top of the other to form the tube (**Figure 1.6**). These two parts are called the labium, which is the thickest and darkest section and the labrum, which is thinner and more transparent. The labium has small teeth (labellar teeth) at the tip, which are used to pierce the hosts' skin. The small tube within the blood-sucking tube is called the hypopharynx that is used to inject saliva into the host blood to stop it from coagulating. It is important to recognize these structures as they are sites for trypanosomes in infected flies and therefore can be dissected and examined microscopically to determine infection rates of tsetse with trypanosomes (see 3.2.5.4.).

1.2.3. Thorax

The thorax (**Figure 1.8**) has already been briefly described; the three pair of legs and one pair of wings are attached to the thorax. As with other Diptera, there is a pair of small club-shaped organs called halteres attached close to the wing attachment. These vibrate and are used to help balance and steer the fly during flight. There are a variable number and size of bristles attached to the thorax that are used for species identification. There are two pairs of spiracles in the sides of the thorax; these are openings leading to tubes called trachea that branch throughout the inside of the tsetse body. These are for respiration, the spiracles allowing air to pass into the trachea to provide oxygen.

1.2.4. Legs

The leg structure (**Figure 1.9**) is similar to that of other insects, being made of four main segments, the coxa, trochanter, femur and tibia and then five smaller tarsal segments ending with two claws and two small pads called pulvilli. All segments except the coxa, which is attached to the thorax, are flexible and can move.

1.2.5. Wings

Characteristic of tsetse flies is that at rest, the two wings lie one on top of the other over the back of the abdomen. The rear trailing edge of the wings is not protected by a thick-

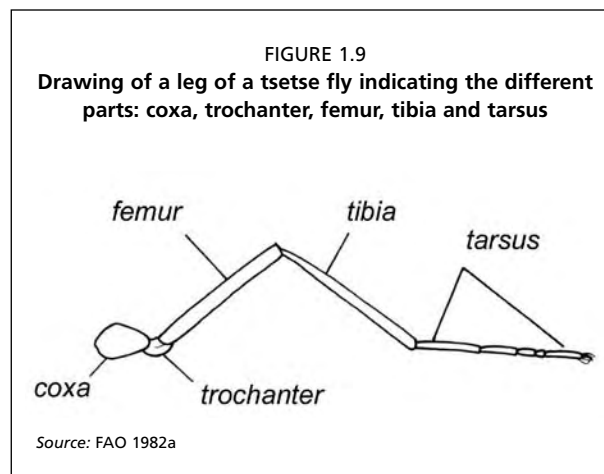
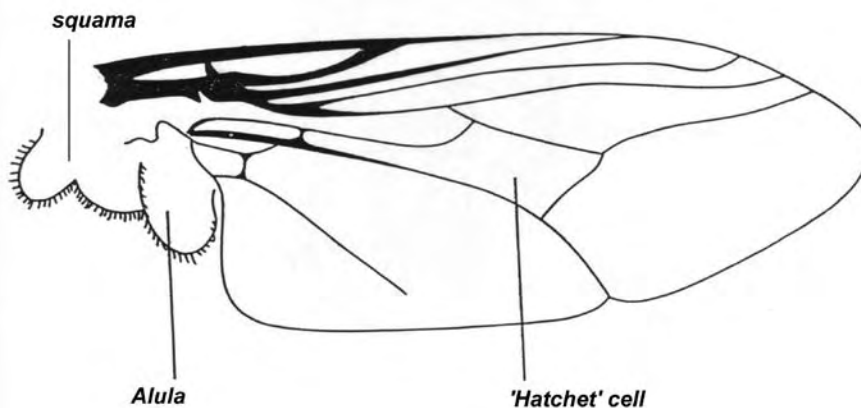
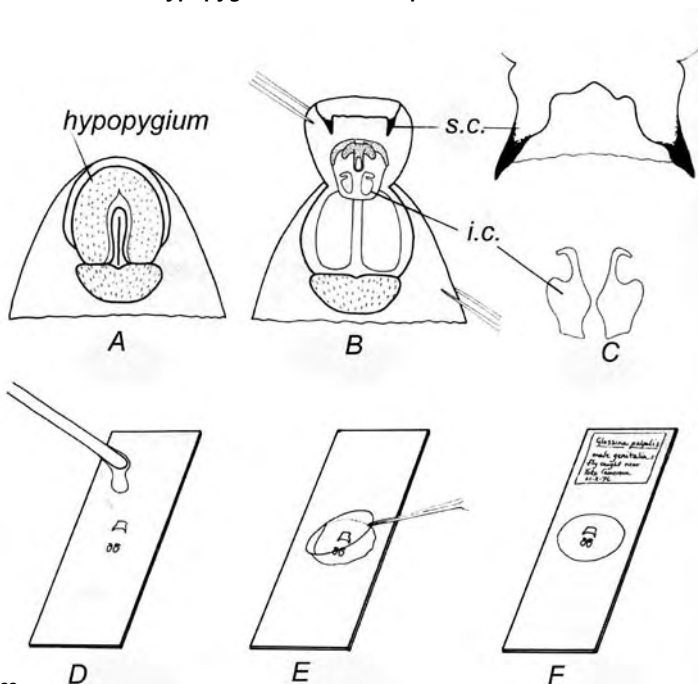

FIGURE 1.10
A diagram of a wing of a tsetse fly indicating the "hatchet cell"



Source: Mulligan 1970

FIGURE 1.11
Drawing indicating (a,b) the location of the hypopygium of the male external genitalia, the inferior (i.c.) and superior claspers (s.c.), and (d,e,f) an illustration of the dissection of the hypopygium for microscopic examination



Source: FAO 1982a

ened vein as the front edge is, and consequently can become increasingly damaged with age as it frays. This can be used as a crude measurement of the relative average age of a tsetse fly population. Another characteristic feature of tsetse that can be used to distinguish them from other flies is that some of the veins in the wings form a cell in the shape of a hatchet or machete; this hatchet cell (**Figure 1.10**) is often cited as a feature for tsetse identification and can also be used as a measure for the size of a tsetse fly.

1.2.6. Abdomen

The abdomen has seven visible segments and the male fly has a structure at the posterior tip, folded underneath the last two segments called the hypopygium (**Figure 1.11**), forming part of the external genitalia. Each segment of the back of the abdomen has a harder cuticle forming a plate or tergite, unlike the elastic ventral surface referred to earlier. The colouring and markings of the tergites are sometimes useful for species identification. There are seven pairs of spiracles, one pair for each segment, along the sides of the abdomen, and an anus at the posterior end.

1.2.7. Genitalia

The genitalia, particularly of the male, are useful features for species identification and are therefore described in some detail here. It is easy to distinguish the sexes of tsetse by the presence of the folded hypopygium at the posterior tip of the abdomen, compared to the female in which there are no equivalent obvious structures, simply a small hole surrounded by a variable number of small flat chitinous plates (**Figure 1.12, left**).

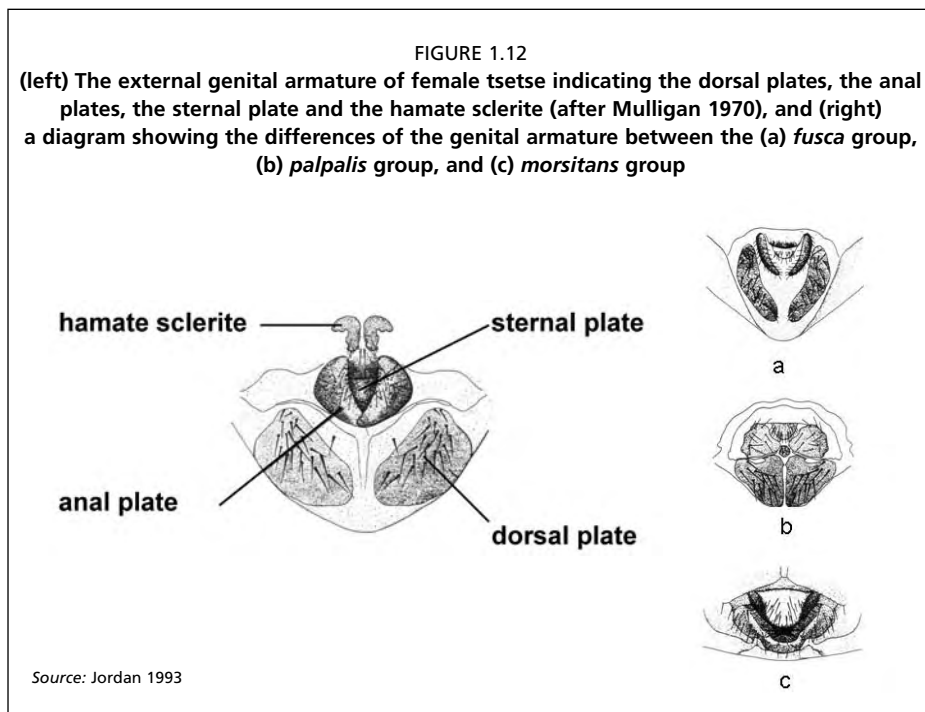

On the male, in addition to the hypopygium, there are hairy plates just in front of it called the hecters. The hypopygium and the hecters are used by the male to hold onto the end of the female's abdomen during mating. When mating starts, the male unfolds the hypopygium revealing the superior and inferior claspers and the penis (or aedeagus). The hypopygium can be unfolded and examined under a dissecting microscope, especially for looking at the superior claspers, in the way shown in **Figure 1.11**.

1.3. INTERNAL ANATOMY

The tsetse fly has two salivary glands that stretch through from the abdomen, through the thorax and head to the proboscis into which they open into the hypopharynx (**Figure 1.13**). The salivary glands produce saliva containing an anticoagulant, preventing the blood of the host from clotting whilst the fly feeds. The glands are very transparent small tubes that can be difficult to see without a microscope but they may be important to recognize as they are the site for development of *Trypanosoma brucei*-complex trypanosomes, which can infect livestock and cause sleeping sickness in humans.

1.3.1. Organs Associated with Feeding and Digestion

When a tsetse fly feeds, it first disengages the proboscis from the maxillary palps and lowers it to the hosts' skin. Using the labellar teeth it then penetrates the skin and cuts small blood capillaries. Blood from these capillaries forms a small pool under the skin and is sucked up through the proboscis by means of a muscular pump in the pharynx. The blood is mixed with saliva from the hypopharynx and then passes down the oesophagus into the muscular proventriculus. Most of the blood continues on from the proventriculus into the crop where it is stored temporarily before being passed back up into the proventriculus

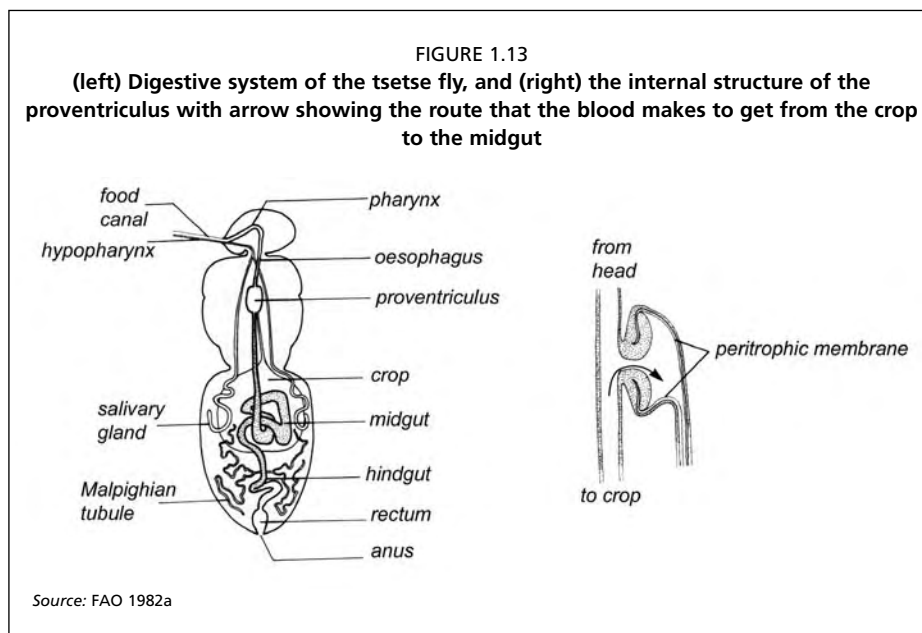

and then to the midgut, where digestion takes place. The crop is a thin, membranous sac, capable of expanding to fill the abdomen with a blood meal. A thin sleeve of chitin, called the peritrophic membrane is formed by the proventriculus and encloses the blood meal as it passes from the proventriculus to the midgut. The peritrophic membrane grows continually and is a significant feature in regard to the development of *T. brucei*-complex trypanosomes. In the midgut, water is rapidly removed from the blood meal so that the fly is able to fly normally again. Digested blood, now dark brown, passes into the hindgut and the waste faeces pass out of the rectum through the anus.

Trypanosomes develop in the proboscis, midgut and salivary glands and therefore it is important to recognize these structures for dissection and examination to determine trypanosome infection rates of tsetse.

1.3.2. Reproductive System

The unusual (for insects) life cycle of the tsetse fly is a very significant feature with regards to control or eradication of the fly and therefore requires a good understanding by those involved in tsetse population management, especially in circumstances involving the release of sterile males. Knowledge of the reproductive system is also essential for a good understanding of this process.

The external male genitalia have already been briefly described. The internal system, in the posterior part of the abdomen, consists of a pair of testes, which are coiled tubes producing and storing sperm, and covered by an orange/brown substance (**Figure 1.14**). Accompanying the testes is a pair of accessory glands which are long, whitish organs with glands producing secretions, which form a bag (spermatophore) containing sperm which is passed into the female's uterus during mating.

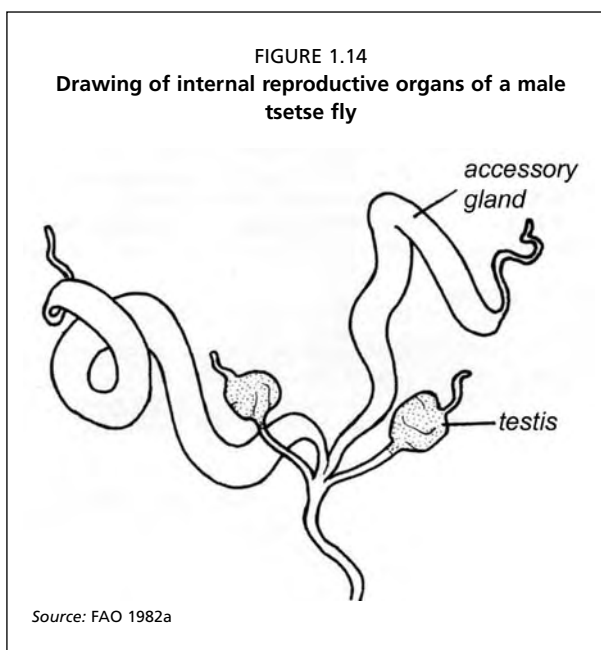

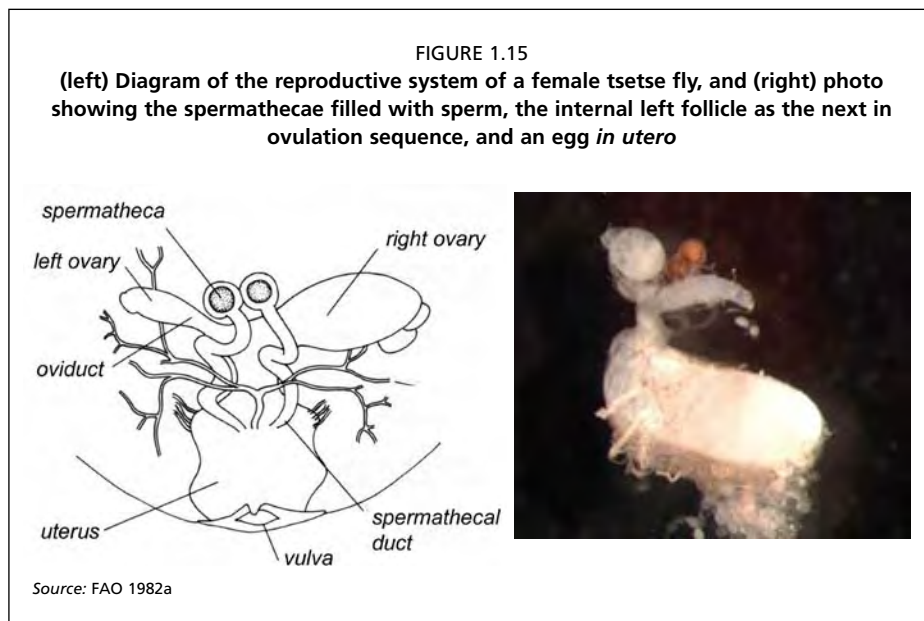

The female reproductive system (**Figure 1.15**, and **Figure 1.16**) consists of a pair of ovaries in which eggs develop. Each ovary has two ovarioles, so the female has a total of four ovarioles. The oocytes mature separately and in a regular sequence, so that only one egg is passed into the uterus at a time. The eggs pass from the ovary to the uterus through a pair of oviducts; these muscular tubes squeeze the mature egg down to where they join as a common oviduct and then into the uterus.

When the female fly is mated and the sperm-containing spermatophore is passed into the females' uterus, the sperm is stored by the female in a pair of spermathecae. These spherical, golden-brown organs store all the sperm from the male and this can last the female for the whole of its reproductive life so it never needs to mate again. Each time a mature egg passes into the female's uterus a small quantity of sperm passes down the spermathecal ducts from the spermathecae into the uterus where one sperm fertilizes the egg. After mating, the spermatophore is expelled from the uterus.

The uterus is a stretchable bag that holds the egg, and the subsequently developing larva as it grows, inside it is a soft sticky "carpet" called the choriothete, on the ventral surface where the egg is held after it enters the uterus. The choriothete is believed to play a role in breaking the membrane ("eggshell") or chorion, when the first stage larva hatches from the egg. There is a branched milk gland or uterine gland in the female's abdomen, which leads into the uterus and which produces a secretion "milk" that nourishes the developing larva within the uterus. Finally, there is an opening at the tip of the abdomen called the vulva, through which the larva is expelled when it is mature.

The sequential nature of the production of eggs, and the fact that as a mature egg bursts out of the membrane surrounding it (called a follicle), leaving a broken piece of tissue behind (a follicular relic), provides a means of ageing female tsetse flies fairly accurately, although this is a delicate dissection, described in 3.2.5.

FIGURE 1.16
(upper) The entire reproductive system, and (lower) detail of the left ovary
of a 20-day-old female *Glossina tachinoides*

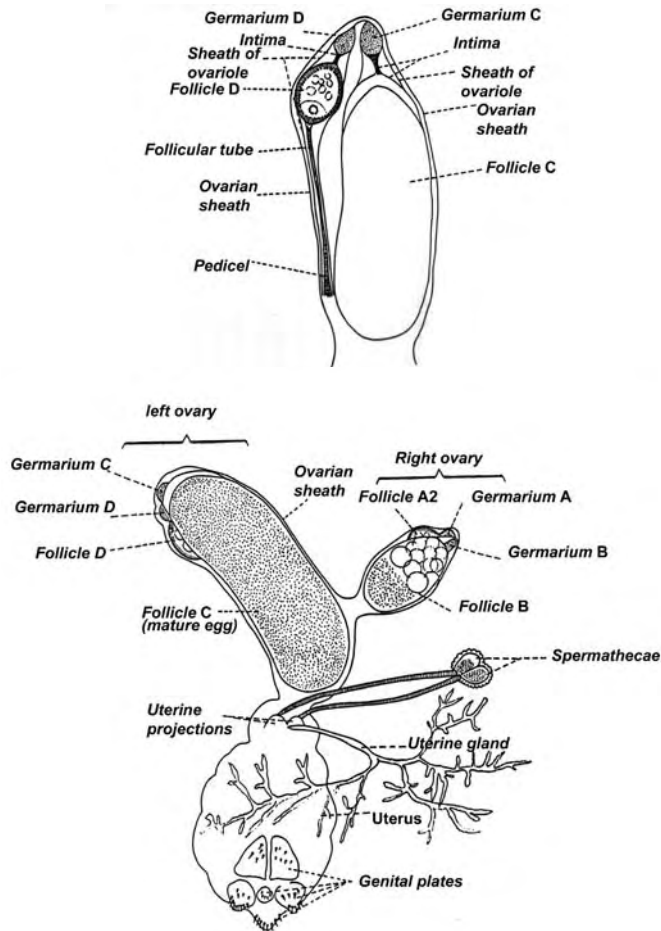

Source: Itard 1966

CIRAD

1.4. LIFE CYCLE

The life cycle of tsetse flies, shown diagrammatically in **Figure 1.17**, differs from many other insects as it produces one offspring, deposited as a 3rd instar larva approximately every nine days. The egg stage up to the 3rd instar larva is kept and nourished in the uterus of the adult female. Female tsetse flies mate shortly after emergence; females looking for a first blood meal may encounter a swarm of males (usually older) (in the *morsitans* group of tsetse) looking for females to mate with. The male lands on the back of the female (**Figure 1.18**), unfolds the hypopygium and clasps the female with the inferior and

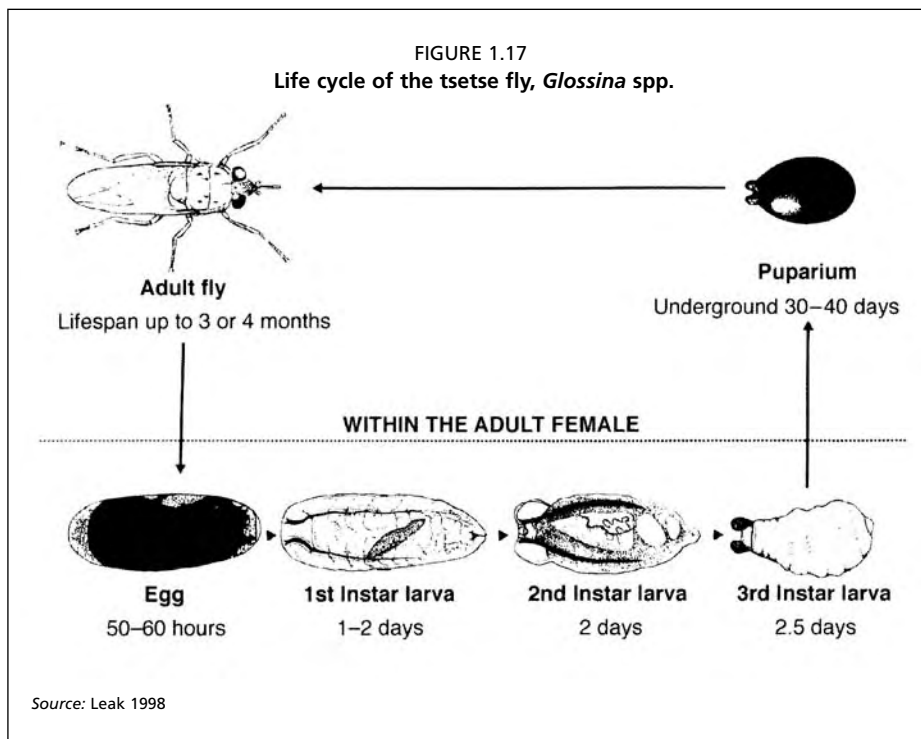

superior claspers. Mating can last a considerable time; up to one or two hours, and during this process the sperm in a spermatophore are passed into the females' uterus in the region where the spermathecal duct enters it, through the penis as described above. The sperm then pass up into the spermathecae for storage for the rest of the females' life. The mature egg is fertilized as it passes into the uterus and develops for approximately four days (embryogenesis) until a first instar larva is ready to emerge. The 1st instar larva breaks out of the chorion with an egg tooth and grows as it is nourished by milk gland secretions in the uterus until it is ready to moult to a 2nd instar larva after about one day. The 2nd instar larva grows and develops rapidly, showing segmentation and development of posterior spiracles and white swellings, that are developing polypneustic lobes, both of which are for respiration. This stage lasts for about two days and *G. morsitans* larvae will grow to about 4.5 mm during this time. The 2nd instar then moults to a 3rd instar larva, the last stage of larval development. In this stage the polypneustic lobes become black or dark brown. This stage lasts a further two days and the larva of *G. morsitans* reaches a length of 6-7 mm. Sometimes if a fly is stressed, for example if it is caught in a trap, the larva is aborted and passes out of the vulva before it is mature. Otherwise, the female deposits the mature 3rd stage larva in a suitable site where it will quickly burrow a few centimetres into soft sandy soil and form a puparium (equivalent of a pupa). The larva becomes barrel shaped and darkens as it changes, after an hour or two, into a pupa, and then has a hard brown case on the outside which is called a puparium.

FIGURE 1.18
Mating tsetse



D. ELSWORTH, ILRI, NAIROBI, KENYA

In the puparium metamorphosis to the adult will take place over a period of approximately 30 days (4–5 weeks) and then the adult will break out from the puparium and will struggle to the soil surface. The crumpled adult expands its wings and body and is known as a teneral fly until it has taken its first blood meal. Approximate durations have been given throughout this description because the development times can vary according to the ambient temperature and environmental conditions.

Tsetse flies have a very slow reproductive rate compared with many other insects; closer to that of a small mammal, so at a temperature of 25°C a female will produce a mature larva once every 9–10 days except for the first one which may be deposited 18–20 days after the emergence of its mother as an adult. This slow reproductive rate should theoretically make control or eradication easier.

1.5. IDENTIFICATION OF TSETSE FLIES

It is essential to know the species of tsetse fly present in an area considered for AW-IPM. Different tsetse species have different habitat preferences and behavioural differences that need to be taken into account when planning their control or eradication. When SIT is considered as part of an integrated approach, the target species or subspecies have to be reared.

Tsetse flies are two-winged flies of the Order Diptera, Family Glossinidae, which has a single genus – *Glossina*. Within this genus, there are three subgenera, *morsitans* (*Glossina*),

palpalis (Nemorhina) and *fusca* (Austenina). These subgenera are differentiated on anatomical features and are also broadly differentiated according to their habitats, thus the *morsitans* group are classed as savannah-inhabiting species, *palpalis* group as riverine or lacustrine species and *fusca* group as forest-inhabiting species.

The tsetse species occurring in any African country are known, as is their approximate distribution, and distribution maps and tables of tsetse species for each country are available either on the internet or in publications (see 1.7). Experienced field workers soon acquire the ability to identify tsetse species by the naked eye. However, it is necessary to confirm species identification based on given characteristics for each species. A standard method of determining species (of tsetse and other animals or plants) is by means of an identification key. Such keys work by having a list of questions, usually in pairs or “couplets”, each of which normally asks you to look at a given feature of the insect and to decide whether it is similar to the first description or not. The answer you give will then lead you to the next question, giving you another choice. At the end of the sequence of questions and answers the key will tell you which species the specimen is. For most AW-IPM operations, a small number of economically important tsetse species will be targeted. However, it may be necessary to identify some unimportant species in the area and therefore a key for identification is given here for all species, with the more important ones highlighted. The key here is adapted from that published in Mulligan (1970) and incorporates material, particularly diagrams, from the FAO training manual for tsetse personnel, Volume 1 (FAO 1982a). The key is updated to include the most recently named species, i.e. *Glossina frezili* (Gouteux 1987). Keys tend to use technical anatomical terms for the features and technical or rather obscure words, not in common use, for describing these structures. These terms are explained by the use of diagrams, accompanying descriptions and a glossary or in some cases are substituted by more understandable terms. Although some characters are quantifiable and can be measured or counted, a drawback of keys used for tsetse identification is that other features are comparative and subjective, and without having two different examples to compare it can be difficult to answer the key question with certainty.

For many of the features in the key a good magnifying glass, or preferably a dissecting microscope is essential.

1.5.1. Key for the Identification of Adults of the Species of *Glossina*

1.5.1.1. By External Characters (Visible with Naked Eye, Magnifying Glass or Dissecting Microscope)

1. Pteropleuron (**Figure 1.8**) bearing a few strong bristles of size equal to those on the sternopleuron, these bristles being clearly distinct from the general vestiture of the shorter setulose hairs on the pleura; hairs fringing the thoracic squamae (**Figure 1.19**) curly and numerous, giving a woolly appearance; large to medium flies (9.5–14 mm) *fusca* group (subgenus Austenina) **2**

Pteropleuron bearing only setulose hairs, of which some may be longer than others, but none equal in size to the clearly differentiated bristles that project from amongst the setulose hairs of the sternopleuron; hairs fringing the thoracic

squamae not curly but giving a neat fringe-like appearance; medium to small flies (6.5–11 mm)

palpalis and *morsitans* groups (subgenera *Nemorhina* and *Glossina* s.s.) **13**

2. Palps shorter than width of the head, or not exceeding it by more than a ninth of their length **3**
 Palps longer than width of the head by a sixth to a third of their length **6**

3. Ground tint of wings dusky; antennal fringe a quarter to a third of greatest width of antenna *tabaniformis* Westwood
 Ground tint of wings pale; antennal fringe a fifth of greatest width of antenna or less **4**

4. Dorsum of thorax with a conspicuous dark brown spot towards each corner (**Figure 1.19**); a pale species (generally light yellowish brown); under side of bulb of proboscis with dark apex *longipennis* Corti
 Dorsum of thorax without any conspicuous dark brown spots; general colour greyish to dark brown; under side of bulb of proboscis uniformly coloured **5**

5. Anterior cross vein of both sexes with thickened portion strongly chitinized and darkened, forming a dark spot on the wing (**Figure 1.20a**) *brevipalpis* Newstead
 Anterior cross vein of female only showing above dark spot *schwetzi* Newstead and Evans
 Anterior cross vein of neither sex showing dark spot (as in **Figure 1.20b**) *medicorum* Austen

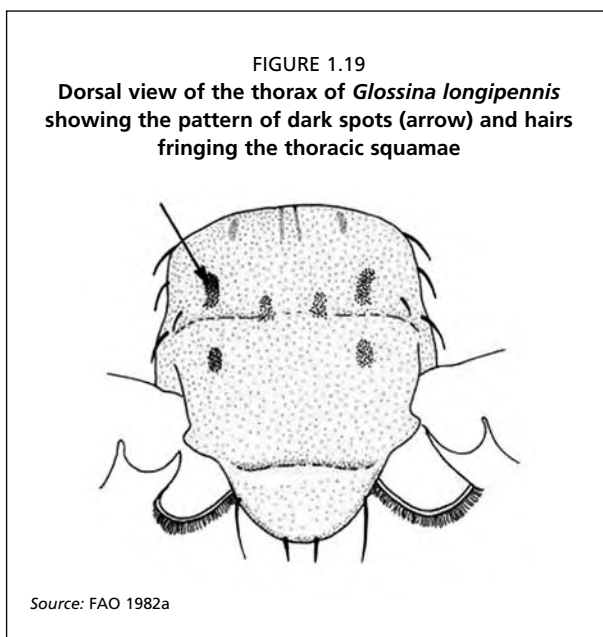

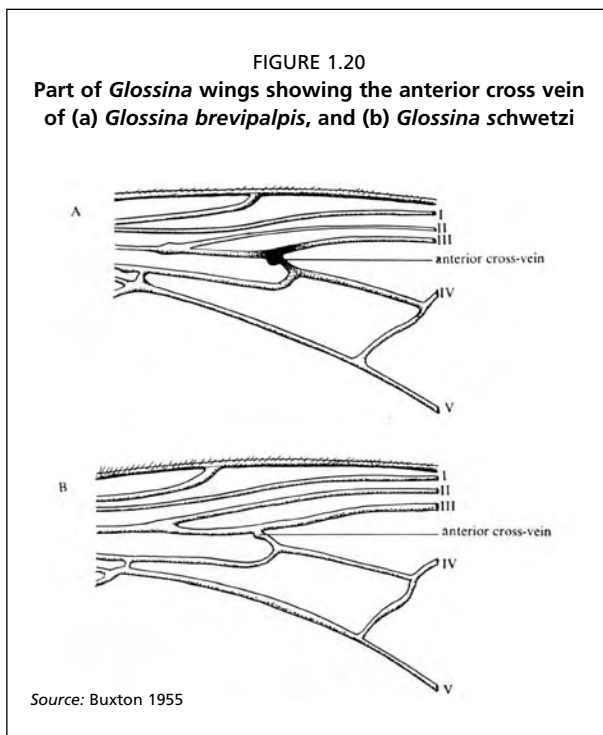

- 6. All segments of hind tarsi uniformly dark dorsally 7
 Only last two segments of hind tarsi dark dorsally, contrasting with paler coloration of remaining segments 8

- 7. Last two segments of fore and middle tarsi pale, or at most showing some darkening at distal margins; pleura and hind coxae fuscous grey; third segment of antenna strongly and gradually recurved at tip, as in *G. nigrofusca* (**Figure 1.21(1)**) 8
severini Newstead
 Last two segments of fore and middle tarsi dark, penultimate at least with dark band at distal extremity and last segment entirely dark dorsally, forming a marked contrast to the remaining tarsal segments; third segment of antenna with a blunt tip, only slightly and abruptly recurved, as in *G. fusca* (**Figure 1.21(3)**)
nashi Potts

- 8. Antennal fringe half to three-quarters of greatest width of third antennal segment; hind tibia with broad dark suffusions in middle and much less distinct one at apex 9
nigrofusca nigrofusca Newstead
 Antennal fringe less than a quarter of greatest antennal width; hind tibiae with or without dark suffusions 9

FIGURE 1.21
Antennae of *Glossina* spp. all to the same scale

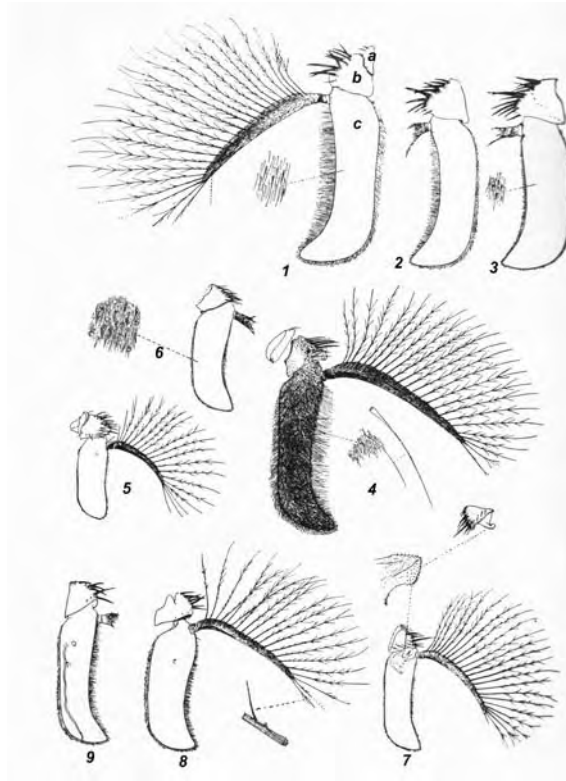

(1) *Glossina nigrofusca* [(a) 1st antennal segment, (b) 2nd antennal segment, (c) 3rd antennal segment],
(2) *Glossina tabaniformis*, (3) *Glossina fusca*, (4) *Glossina pallicera*, (5) *Glossina tachinoides*, (6) *Glossina palpalis*,
(7) *Glossina morsitans*, (8) *Glossina longipalpis*, (9) *Glossina pallidipes*

Source: Buxton 1955

9. Infra-alar bulla (**Figure 1.8**) dark brown to fuscous, without any pale vertical streak in centre
fuscipluris Austen
Infra-alar bulla testaceous, often with pale vertical streak in centre **10**
10. Antennal fringe about a fifth of greatest width of third antennal segment
haningtoni Newstead and Evans
Antennal fringe less than a sixth of greatest width of third antennal segment
(**Figure 1.21 (1)**) **11**
11. Hind tibiae with dark diffusions in middle and a much less distinct one at apex
nigrofusca hopkinsi van Emden

- Hind tibiae without dark diffusions, and if former, with a scarcely less distinct infuscation at the apex than at the base **12**
- 12.** Palps grey black; first three segments of hind tarsi brown *vanhoofi* Henrad
 Palps buff or dusky to grey brown; first three segments of hind tarsi yellowish or ochraceous buff (but may sometimes tend to brownish) *fusca* Walker
- 13.** All segments of hind tarsi dark brown or blackish when viewed from above; dorsum of abdomen usually uniformly brown, generally dark brown, not showing distinct transverse dark bands on a paler background
palpalis group (subgenus *Nemorhina*) and some forms of *austeni* **14**
 Only distal segments of hind tarsi dark brown or blackish, generally contrasting strongly with paler proximal segments; dorsum of abdomen generally with distinct dark bands showing against a paler background
morsitans group (subgenus *Glossina* s.s.) **22**
- 14.** Dorsal surface of abdominal segments with interrupted dark banding on a pale yellowish background *tachinoides* Westwood
 Dorsal surface of abdominal segments without distinct banding on a pale yellowish background **15**
- 15.** Dorsal surface reddish ochraceous; small flies (7.5–8.5 mm)
austeni (*Glossina* s.s.)

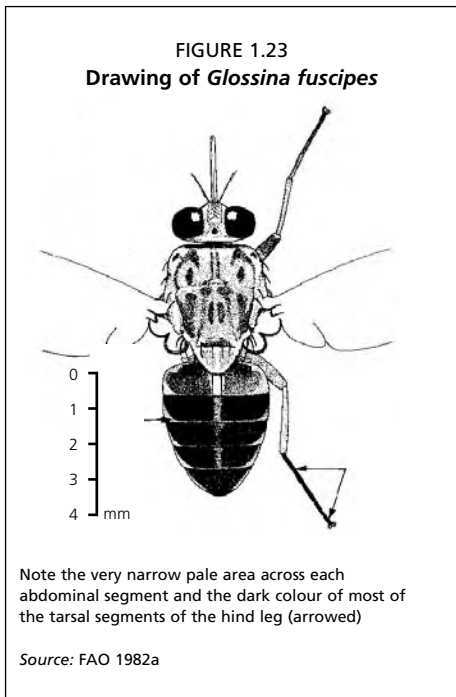
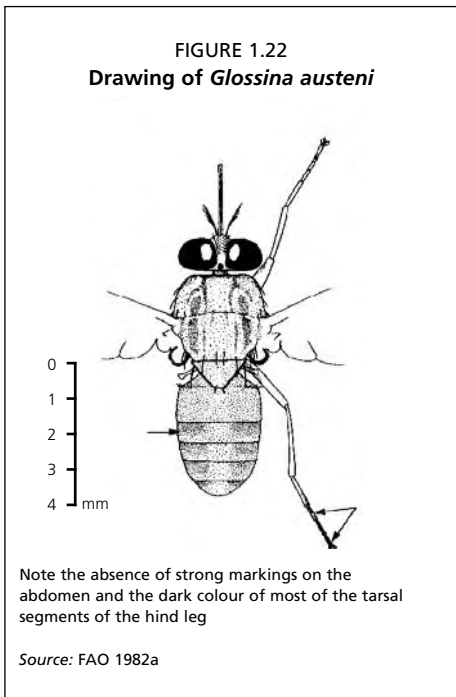

Dorsal surface of abdomen brown to dark brown (sepia or clove); large flies (8.5–11 mm) **16**

16. Fringe of hairs on anterior edge of third antennal segment a quarter of the antennal width or longer (*pallicera* s.l.) **17**

Fringe of hairs on anterior edge of third antennal segment a sixth of antennal width or shorter **18**

17. Third antennal segment usually narrow relative to its length and strongly curved at apex (**Figure 1.21 (4)**); antennal fringe about three-fifths of antennal width
pallicera pallicera Bigot

FIGURE 1.24
Drawing of external genitalia of tsetse

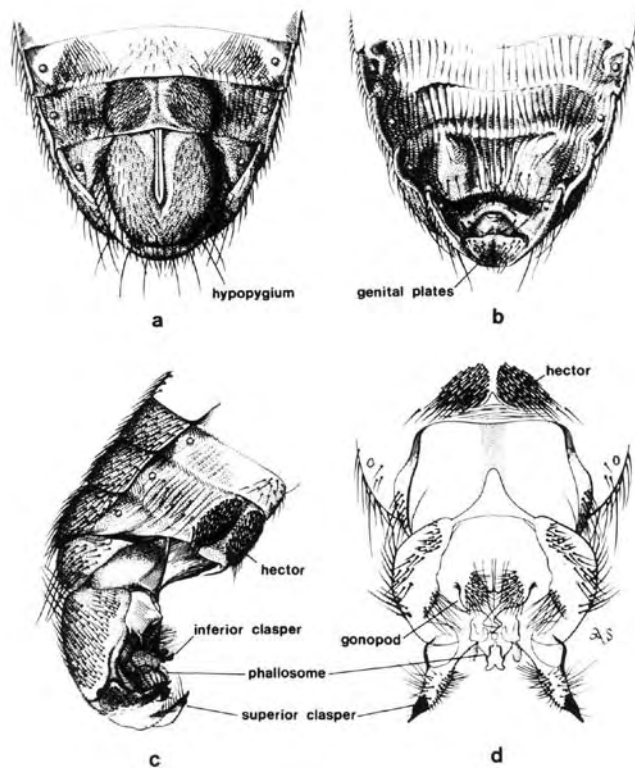

(a) hind end of the abdomen of male *Glossina* viewed from beneath, showing knob-like appearance of hypopygium drawn up into the abdomen, (b) hind end of abdomen of female *Glossina* viewed from beneath, showing absence of any knob-like hypopygium, (c) hind end of abdomen of male *Glossina* with hypopygium extended, viewed from a ventro-lateral position, and (d) hypopygium of *Glossina* after maceration and flattening under a coverslip

Source: Jordan 1993

- Third antennal segment not as preceding, more like a pea pod in shape; antennal fringe a quarter of antennal width *pallidipallica newsteadi* (Austen)
- 18.** Dorsal surface of abdomen dark to sepia brown, hind margins of segments not narrowly paler than rest; a wide, more or less square median pale area on second tergite *caliginea* Austen
Hind margins of dorsal surfaces of abdominal segments narrowly paler, and median pale area on second tergite narrow and elongated **19**
- 19.** Colour of dorsal surface of abdomen variable but general tendency is to be very dark; posterior margin of hectors (see **Figure 1.24c,d**) in form of a shallowly concave curve, or straight *fuscipes* s.l. **20**
Colour of dorsal surface of abdomen variable but general tendency is to be less dark; posterior margin of hectors deeply cleft by a forwardly pointed triangle *palpalis* s.l.
- 20.** Posterior margin of hectors straight, and with uninterrupted covering of hairs *fuscipes quanzensis* Pires
Posterior margin of hectors shallowly concave, and with median interruption of the covering of hairs **21**
- 21.** General coloration pale; glabrous interruption on hind margin of hectors a narrow line *fuscipes martinii* Zumpt

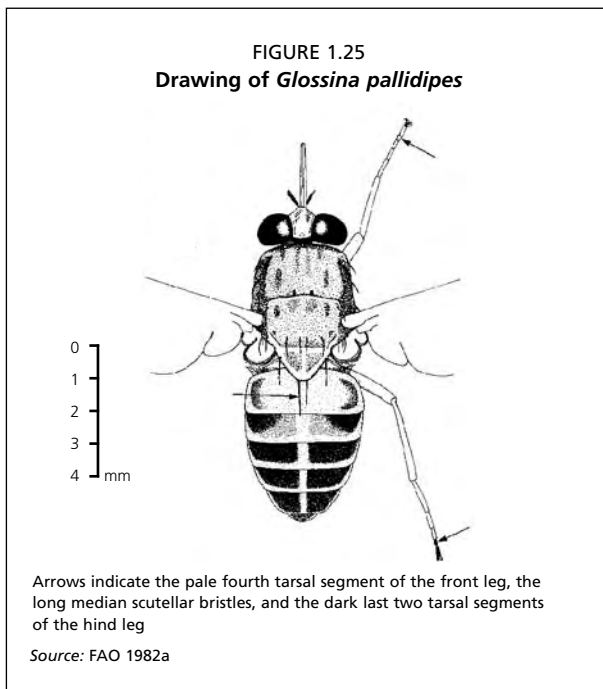

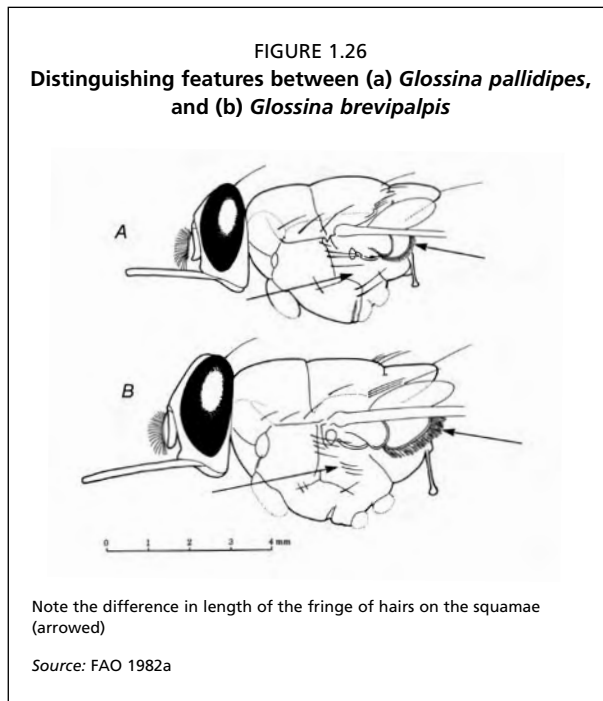

General coloration darker; glabrous interruption on hind margin of hectors triangular, with apex directed forwards *fuscipes fuscipes* Newstead

22. Antennal fringe a fifth to a third of antennal width 23
 Antennal fringe not more than a sixth of antennal width 24

23. Front and middle tarsi uniformly yellowish brown; length of third antennal segment about five times its width, tip strongly recurved and tapering; antennal fringe a third of antennal width (**Figure 1.21 (9)**) *pallidipes* Austen

Front and middle tarsi with strongly defined dark tips; length of third antennal segment about 3.5 times its width, tip only slightly and abruptly recurved and not tapering; antennal fringe a fifth to a quarter of antennal width (**Figure 1.21 (8)**)

longipalpis Wiedemann

Where *G. pallidipes* (**Figure 1.25**) and *G. brevipalpis* occur together, an additional feature that can be used to distinguish the two species is the length of the fringe of hairs on the squamae, which are short on *G. pallidipes* and long on *G. brevipalpis* (**Figure 1.26**).

24. Dorsal surface of abdomen reddish ochraceous to yellowish buff, with only rather indistinct darker transverse bands, dark brown to black; last two segments of hind tarsi not very much darker than the brownish proximal segments

austeni Newstead

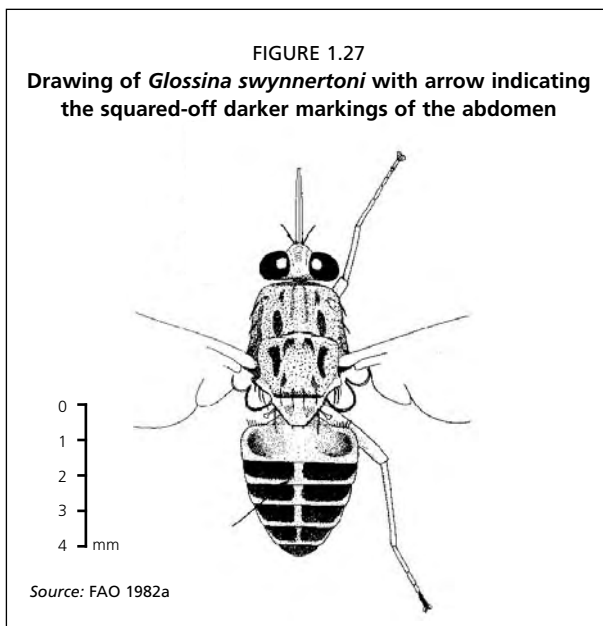

Dorsal surface of abdomen yellowish or greyish yellow, with distinct medially interrupted dark transverse bands; last two segments of hind tarsi dark, strongly contrasted with the pale yellowish-brown proximal segments **25**

- 25.** Hind margins of abdominal dark bands generally not very clearly defined and inner corners rounded (only occasionally somewhat truncate, e.g. some forms of subspecies *submorsitans*), so that median pale line is not very sharply defined

morsitans (s.l.)

Hind margins of dark bands clearly defined and inner corners squarely truncate, so that narrow median pale line is very distinct (**Figure 1.27**) *swynnertoni* Austen

1.5.1.2. By the Characters of the Male Terminalia

- 1.** Superior claspers narrowing to a distal extremity, which terminates in a tooth or claw; claspers free, not joined by a membrane (**Figure 1.28a**)

fusca group (subgenus Austenina) **15**

Superior claspers joined by a membrane; may terminate in a tooth or claw as in preceding (**Figure 1.28b**) or distal extremity may be dilated (**Figure 1.28c**) **2**

- 2.** Superior claspers terminating in a tooth or claw

palpalis group (subgenus Nemorhina) **3**

Superior claspers dilated and distal extremity club like

morsitans group (subgenus *Glossina* s.s.) **11**

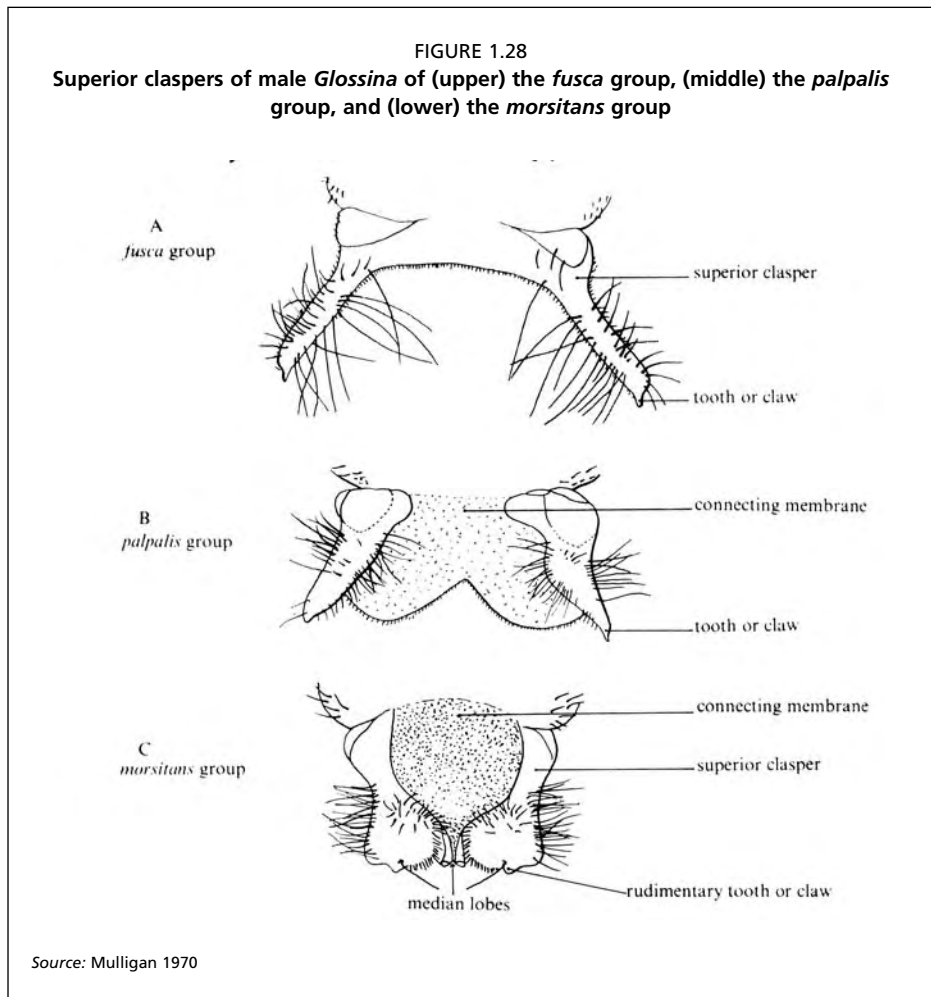

3. Superior claspers with free tooth or claw very long, almost a third of the length of the clasper; inferior claspers with head swollen, not foot like, and notched, giving bilobed appearance, but not bifurcated (**Figure 1.29h**). West Africa, from Ghana to Cameroon, Gabon and northern Democratic Republic of the Congo
caliginea
- Superior claspers with free tooth or claw short, very much less than a third of the length of the clasper; inferior clasper with foot like head (**Figure 1.29a,g,i**) **4**
4. Inferior clasper with head bifurcated (**Figure 1.29f,g**) **5**
- Inferior clasper with head not bifurcated (**Figure 1.29a-e,i**) **6**
5. Internal lobe of inferior clasper with flattened outline (**Figure 1.29f**). West Africa, Sierra Leone to Cameroon
pallicera pallicera

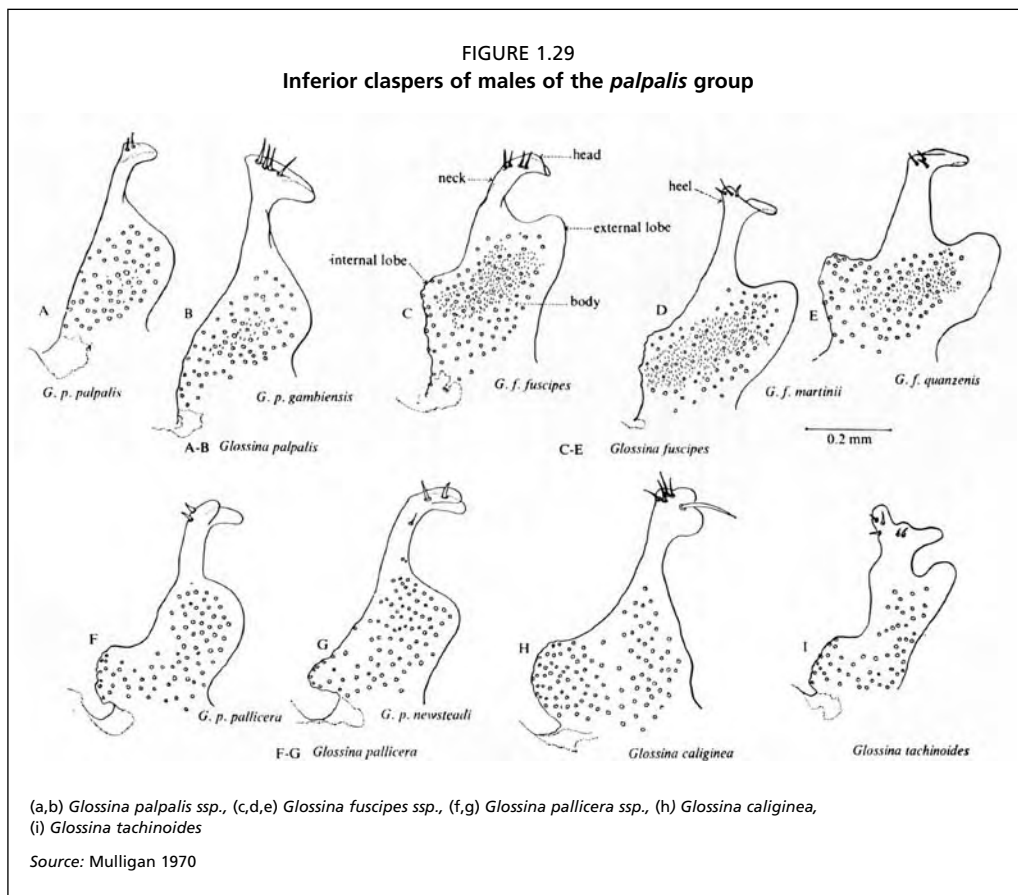

Internal lobe of inferior clasper with pointed outline (**Figure 1.29g**) Gabon, Ubangui-Shari, Democratic Republic of the Congo, north-western Angola
pallicera newsteadi

6. Neck of inferior clasper short, about as broad as long (**Figure 1.29i**). Hinterland of West Africa to Sudan and Ethiopia; Saudi Arabia and Yemen *tachinoides*
Neck of inferior clasper long, plainly longer than broad (**Figure 1.29a-e**) **7**

7. Inferior claspers with external lobe (see **Figure 1.30, right**) prominent and projecting at least slightly upwards; internal lobe present and generally prominent (**Figure 1.29c-e**) *(fuscipes* s.l.) **8**

Inferior claspers with external lobe not prominent and not projecting, even slightly upward; no internal lobe (**Figure 1.29a,b**) *(palpalis* s.l.) **10**

8. Terminal dilation of inferior claspers (“head”) in form of a curved pointed hook, the curve prolonging that of the neck; internal lobe of “body” of inferior clasper not

projecting strongly (**Figure 1.29c**). Central and eastern Africa generally (in region of the great forest and the central African lakes) *fuscipes fuscipes*

Terminal dilation of inferior claspers more or less foot like; internal lobe of inferior claspers may or may not project strongly (**Figure 1.29d,e**) **9**

9. Terminal dilation of inferior claspers markedly foot like, with pronounced "head"; "sole" markedly concave; internal lobe of inferior claspers not projecting strongly (**Figure 1.29d**). Democratic Republic of the Congo, Tanzania, Zambia (from Lualaba to Luapula rivers and Lake Tanganyika) *fuscipes martinii*

Terminal dilation of inferior claspers not so markedly foot like, heel not very pronounced; "sole" more or less flat; internal lobe of inferior claspers projecting strongly (**Figure 1.29e**). Central African Republic, Democratic Republic of the Congo, Angola *fuscipes quanzensis*

10. Terminal dilation ("head") of inferior claspers relatively small, its width plainly less than length of "neck" which emerges abruptly from the "body" of the clasper (**Figure 1.29a**). West Africa, from Nigeria to southern Angola

palpalis palpalis

Terminal dilation of inferior claspers relatively large, its width markedly exceeding length of "neck" which merges gradually into the "body" (**Figure 1.29b**). West Africa, from Senegal to Ivory Coast *palpalis gambiensis*

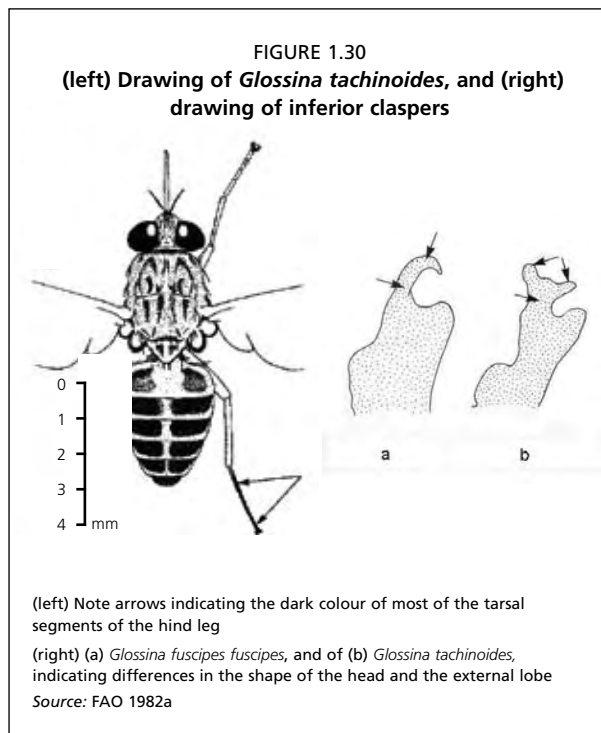

- 11. Outer lateral angle of superior claspers forming a blunt tooth (Figure 1.31a,b) 12
- Outer lateral angle of superior claspers either rounded or strongly produced, not forming a tapering tooth (Figure 1.31c-e) 13

- 12. Tooth of superior claspers subterminal; length of line of junction between the two inner flange-like extensions of the claspers about equal to greatest width of

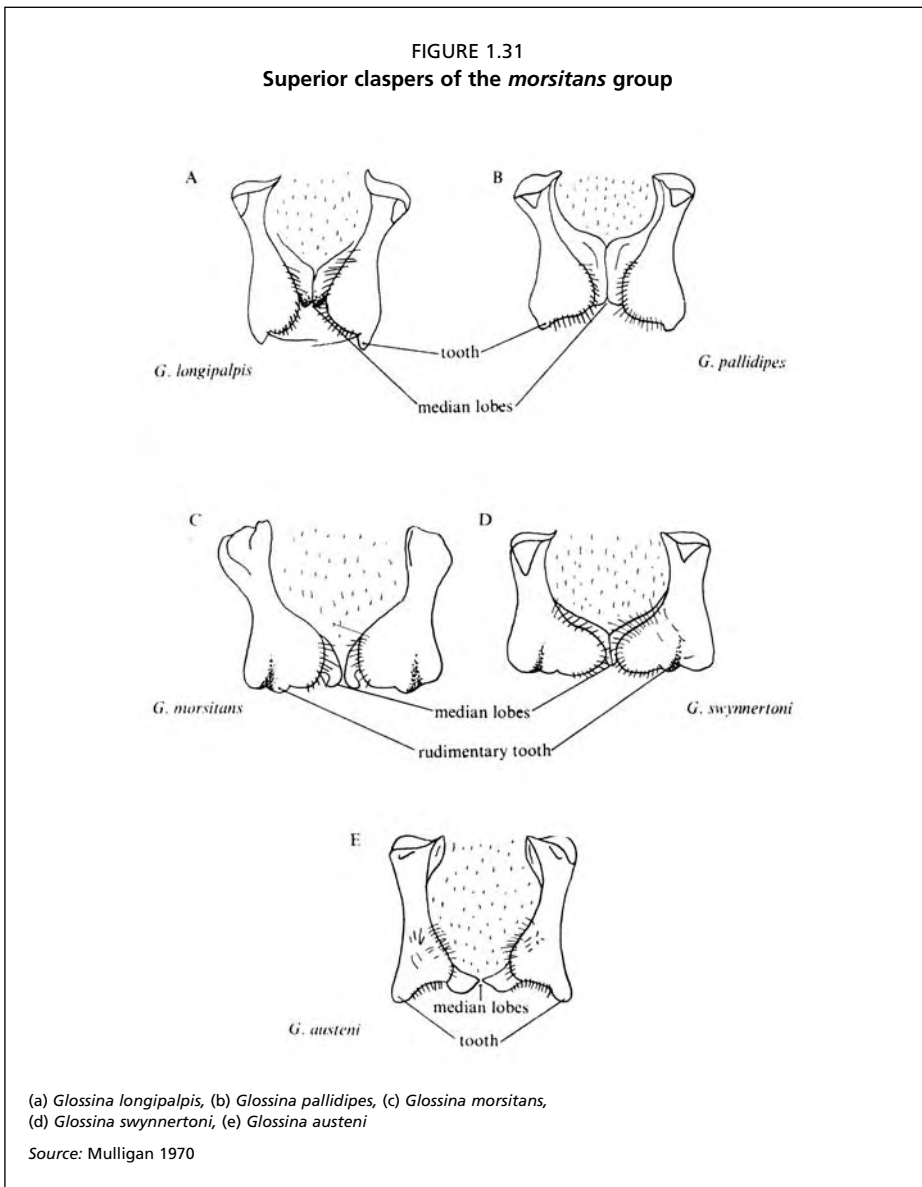
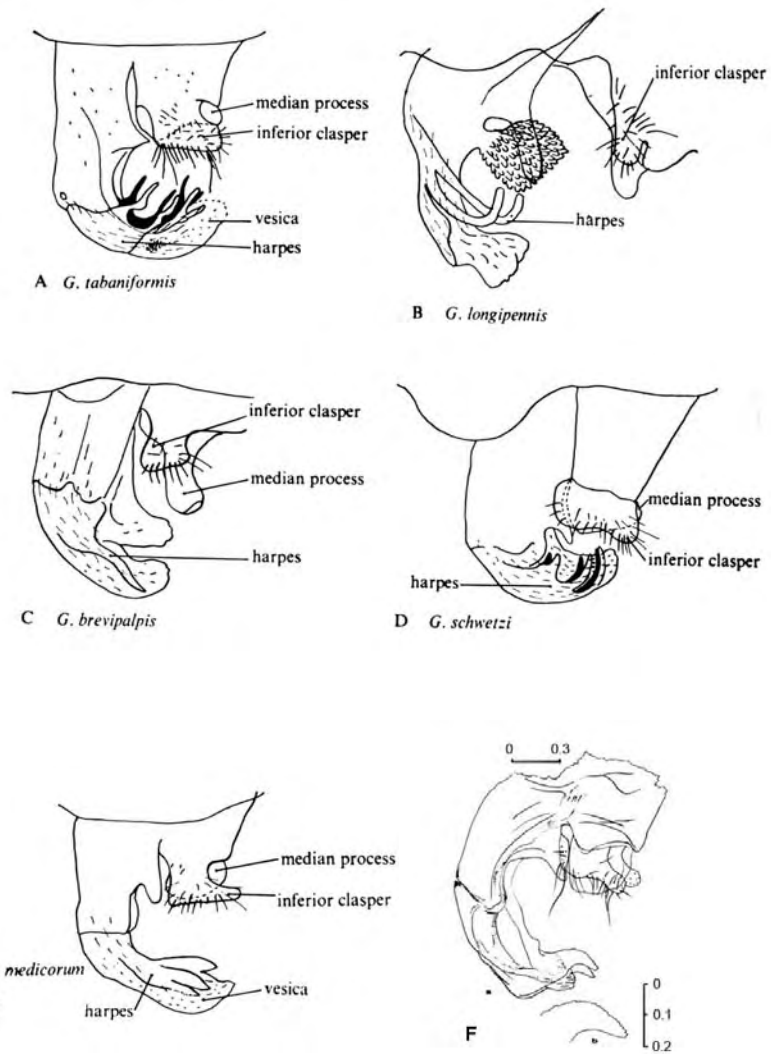

FIGURE 1.32
Lateral views of male terminalia of species of the *fusca* group



(a) *Glossina tabaniformis*, (b) *Glossina longipennis*, (c) *Glossina brevipalpis*, (d) *Glossina schwetzi*,
(e) *Glossina medicorum*

Source: Potts 1973

(f) *Glossina frezili*

Source: Gouteux 1987

FIGURE 1.33
Lateral views of male terminalia of species of the *fusca* group

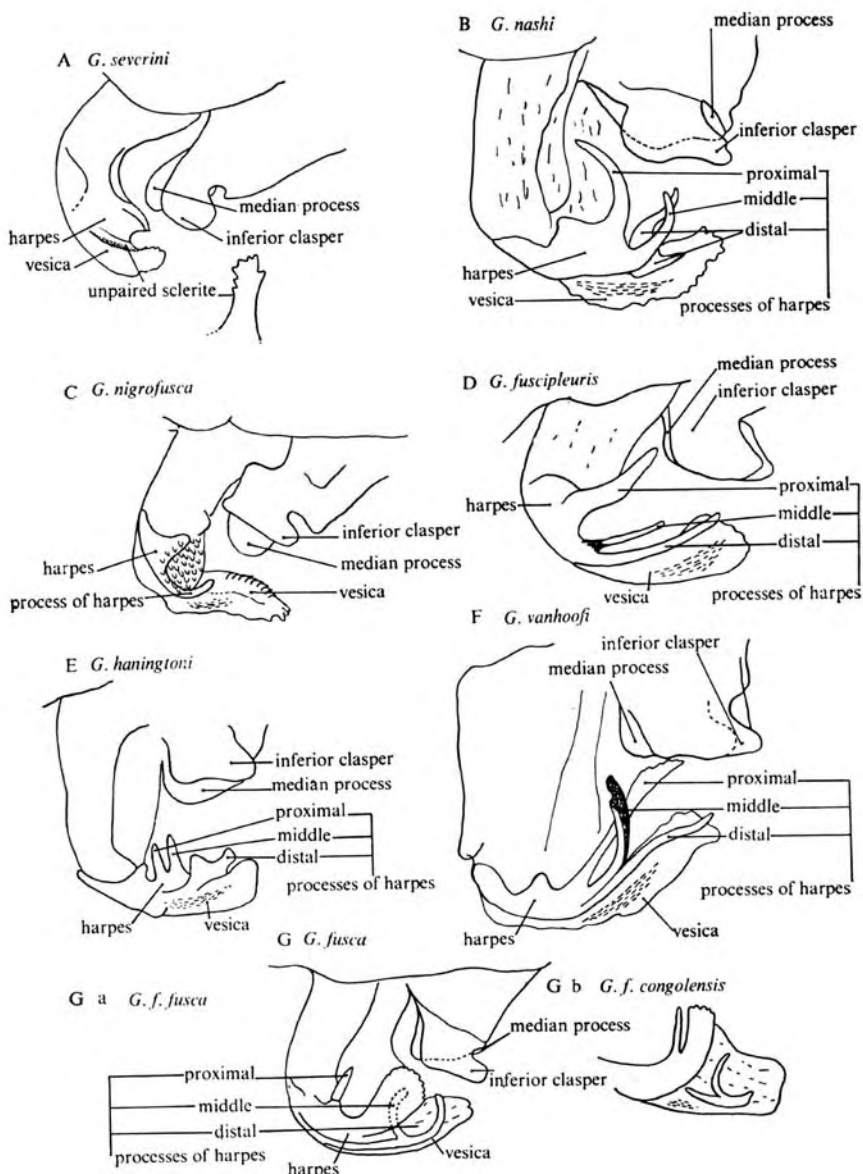

(a) *Glossina severini*, (b) *Glossina nashi*, (c) *Glossina nigrofusca*, (d) *Glossina fuscipleuris*, (e) *Glossina haningtoni*, (f) *Glossina vanhoofi*, (g/a) *Glossina fusca fusca*, and (g/b) *Glossina fusca congolensis*

Source: Mulligan 1970

the claspers (**Figure 1.31b**). Central and eastern Africa, Somalia and Ethiopia to Southern Mozambique *pallidipes*

Tooth of superior claspers terminal; length of line of junction between the inner extensions of the claspers plainly less than the greatest width of the claspers (**Figure 1.31a**). West Africa, from Zambia to Cameroon *longipalpis*

- 13.** Outer lateral angles of superior claspers strongly produced and narrowly rounded (**Figure 1.31e**). East African coastal regions, Somalia to KwaZulu Natal (South Africa), extending inwards as far as 33° and 38° in Tanzania and Mozambique, respectively *austeni*

Outer lateral angles of superior claspers rounded and not strongly produced (**Figure 1.31c,d**) **14**

- 14.** Median lobes of superior claspers with broad tips, turned outwards and generally ending level with or projecting slightly beyond the swollen distal portion of the claspers (**Figure 1.31c**). West, Central and East Africa

morsitans s.l.

BOX 1.1

Differentiation of the *morsitans* subspecies

Machado (1970) recognized four subspecies of *morsitans* differentiated as follows:

- a. Superior claspers with external distal angle rounded; rudimentary tooth of the claspers distinctly projecting beyond the level of the external angle of the clasper (as in **Figure 1.31e**) **b**
- Superior claspers with distal angle bluntly pointed; rudimentary tooth not projecting beyond the level of the external angle of the claspers (*morsitans submorsitans*) **c**
- b. Median lobes relatively feeble and narrow, with tips only slightly divergent *morsitans morsitans*
- Median lobes robust and relatively wide, with tips markedly divergent (as in **Figure 1.31c**) *morsitans centralis*
- c. Median lobes relatively feeble and narrow, with tips only slightly divergent *morsitans submorsitans* (type)
- Median lobes robust and relatively wide, with tips markedly divergent *morsitans submorsitans ugandensis*

Median lobes of superior claspers with small pointed tips, not generally reaching the level of the distal edge of the claspers (**Figure 1.31d**). Kenya and Tanzania
swynnertoni

- 15. A very prominent median process projecting between the inferior claspers for twice their length or more (**Figure 1.32c**). East and Central Africa, from south-western Ethiopia and southern Somalia through Kenya to Zululand and to south-eastern Democratic Republic of Congo
brevipalpis
Median processes not prominent and generally projecting only slightly if at all between the inferior claspers (**Figure 1.33a,d**) and never projecting for more than their length (**Figure 1.33b,c**) **16**

- 16. Harpes poorly developed and not properly differentiated from the general chitinization of the aedeagus, without projecting processes (**Figure 1.33a**). Eastern part of Democratic Republic of Congo
severini
Harpes well developed, with one or more freely projecting processes (**Figure 1.33a,b**, etc.) **17**

- 17. Harpes with one pair of freely projecting processes **18**
Harpes with three such pairs **20**

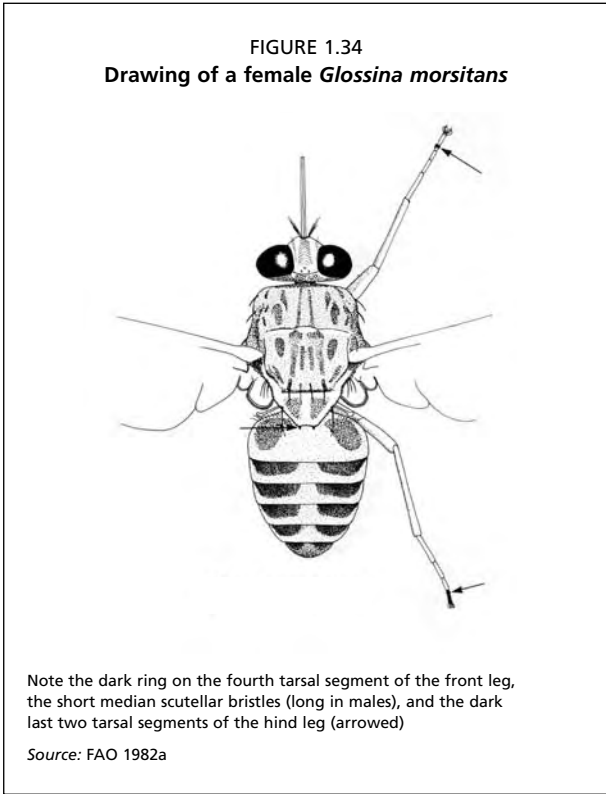

18. Processes of harpes bifid (**Figure 1.32e**). Coast of Gulf of Guinea and Liberia to Nigeria *medicorum*
Processes of harpes simple, not bifid **19**
19. Harpes consist of a pair of long slender processes curving upwards and tapering (**Figure 1.32b**). Northern East Africa including the southern border of the Sudan, Ethiopia, Somalia, Kenya, northern Uganda and northern border of Tanzania *longipennis*
Harpes consist of a basal triangular portion, the bottom corner of which is drawn out into a bluntly ending process, strongly chitinized; covered by a membrane thickly studded with short squamiform (scale-like) spines (**Figure 1.33c**). (The male terminalia do not differ in the two subspecies of *G. nigrofusca* but these are easily differentiated by other characters (see 1.5.1.1, couplets 8-11)). West Africa, Liberia, Ivory Coast, Ghana, Nigeria and along the northern border of the Democratic Republic of the Congo and adjacent portions of territories to north and west of these, as *n. nigrofusca*; extreme east of Democratic Republic of the Congo and extreme west of Uganda *n. hopkinsi nigrofusca*
Harpes large and arched; toothed (**Figure 1.32f**) *frezili*
20. None of the three pairs of processes with bifid members (**Figures 1.33d, 1.34f**) **21**
Distal pair of processes with bifid members (**Figures 1.33a, 1.34b**) **23**
21. Harpes with the processes of the proximal and middle pairs dilated towards their tips, only the distal ones tapering to a point; all three pairs of approximately the same length (**Figure 1.33f**). Eastern edge of equatorial forest in the Democratic Republic of the Congo from its boundary with the Central African Republic to the Kivu area *vanhoofi*
Harpes none of the processes dilated distally; pairs of processes not all of approximately the same length (**Figures 1.33d, 1.34d**) **22**
22. Harpes with proximal pairs of processes the shortest of the three pairs (**Figure 1.32d**) Central Africa, Republic of Congo, western Democratic Republic of the Congo and Angola (on the Congo river system) *schwetzi*
Harpes with the middle one of the three pairs of processes the shortest; the processes of the last pair characteristically with a dark base, the rest of it being clear and somewhat transparent (**Figure 1.33d**). Central Africa (Cameroun), Democratic Republic of the Congo, southern Sudan, Uganda, and western Kenya *fuscipleuris*
23. Harpes with processes of all three pairs tapering to a point **24**
Harpes with processes of one or other of pairs dilated distally or in form of blunt protuberances (**Figure 1.33e**) **25**

- 24.** Harpes with proximal pairs of processes markedly longer than the other two pairs, characteristic form and disposition of the processes as shown in **Figure 1.33b**. Southern Sardauna province of Nigeria, Central African Republic, Republic of Congo, Gabon and Angola (Belize, in Kabinda area) *nashi*
 Harpes with proximal pairs of processes not markedly longer than the other two pairs, characteristic form and disposition of the processes as shown in **Figure 1.32a**. West coast of Africa (Ivory Coast and Ghana, and from Nigeria to the Democratic Republic of the Congo, where stretches inland nearly to the eastern boundary of that territory) *tabaniformis*
- 25.** Proximal and middle pairs of processes of harpes peg like; processes of distal (bifid) pair in form of blunt protuberances (**Figure 1.33e**). West and Central Africa (south-western corner of Nigeria to Republic of Congo, Democratic Republic of the Congo and Angola (in the Kabinda area)) *haningtoni*
 Middle pair of harpes with processes dilated distally, the proximal and distal (bifid) pairs with pointed processes (**Figure 1.33g**) **26**
- 26.** A macrophallic form; proximal pair of processes stout, short and peg like reaching to about the middle of the second pair, members of which are broadly dilated distally, with shallowly convex serrated distal margin, and relatively broad shafts; distal arm of the bifid sickle-shaped distal process as long as the proximal part (**Figure 1.33g(a)**). West Africa (Republic of Guinea to central southern Ghana) *fusca fusca*
 A microphallic form; proximal pair of processes straight, more slender, longer and tapering gradually to a point, about as long as the second pair, members of which are less broadly dilated and truncated distally, with straight serrated distal margin; distal arm of bifid sickle-shaped distal process about half the length of the proximal one or less (**Figure 1.33g (b)**). West and Central Africa (south-western Ghana and Benin to western Uganda and Democratic Republic of the Congo, as far south as the south-eastern corner near the border of Angola) *fusca congolensis*

1.5.1.3. By the Female Genital Armatures and Signa

- 1.** External genital armature consists of five or six well-defined chitinous plates (**Figures 1.12, left**); signum (a chitinized plate of the anterior end of the uterus (**Figure 1.35**)) may or may not be present **2**
 External genital armature very much reduced, well-defined chitinous plates being generally absent and not exceeding three if present (**Figure 1.12c**); signum never present *morsitans* group (subgenus *Glossina* s.s.)
- 2.** External genital armature consists of five well-defined chitinous plates (**Figure 1.12a**); signum present in all species except one *fusca* group (subgenus *Austenina*) **3**
 External genital armature consists of six well-defined chitinous plates (**Figure 1.12b**); signum never present *palpalis* group (subgenus *Nemorhina*) **15**

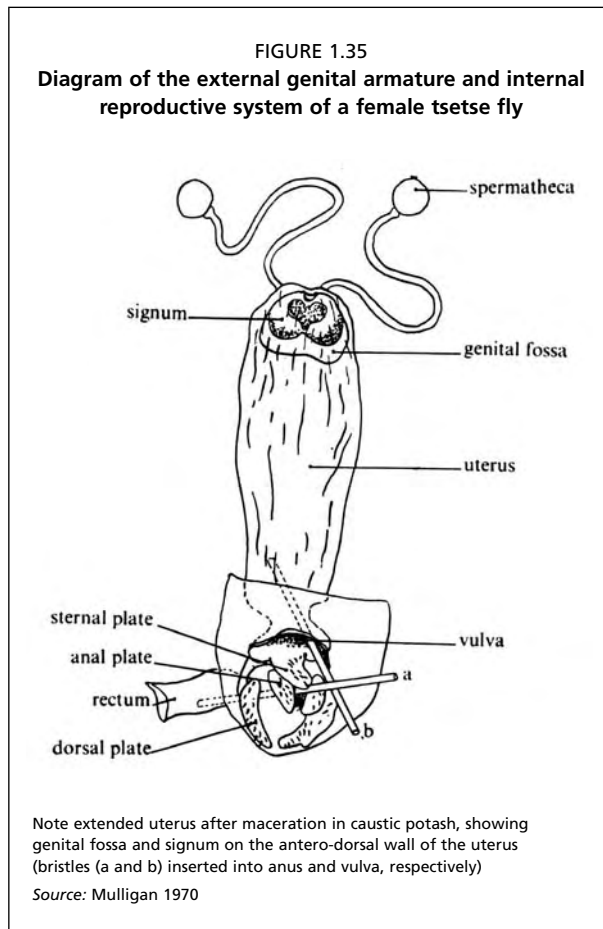

3. No signum; in addition to the well defined chitinous plates there are two "hamate" (hook- or comma-shaped) sclerites at the base of the anal plates (found only in this species) *brevipalpis*
Signum always present, though it may be only very weakly chitinized in freshly emerged specimens, particularly in some species (e.g. *G. longipennis*) **4**
4. Signum consists of separated paired chitinous plates **5**
Signum consists of single unpaired chitinous plates **6**
5. Signum much reduced, the "plates" being only two widely separated submedial strips of pale chitin running upwards from the bottom of the genital fossa to about half way up it (**Figure 1.36g**) *nigrofusca*
Signum not reduced, the plates being well defined, and of characteristic shape, expanded at the tip and approximated to one another, occupying most of the genital fossa (**Figure 1.36e**) *severini*

6. Signa elongated vertically, somewhat lyriform in shape (**Figure 1.36a,h**) **7**
 Signa of various shapes but never lyriform **8**
7. Signum strongly flexed or even bent double in the middle of its length, sides roughly parallel, with two transverse constrictions towards bottom and top (**Figure 1.36h**) *fuscipleuris*
 Signum not flexed and sides not roughly parallel, divided into two unequal portions by a transverse constriction, the bottom margin with divergent horns laterally and the top one more or less deeply bifurcate (**Figure 1.36a**) *tabaniformis*
8. Signum cordiform in outline (**Figure 1.36d**) *medicorum*
 Signum distinct and formed of two flat hollowed out shell-like plates placed opposite to each other along their length (**Figure 1.37**) *frezili*
 Signum not cordiform **9**
9. Signa with conspicuous paired dark-curved chitinous thickenings (as in **Figure 1.36c**) **10**
 Signa without such thickenings **13**
10. Signa subrotund **11**
 Signa not subrotund **12**
11. Signum mainly composed of two lobes separated anteriorly by a deep V-shaped depression (**Figure 1.36k(a)**) *fusca fusca*
 Signum mainly composed of two lobes separated anteriorly by only a shallow depression (**Figure 1.36k(b)**) *fusca congolensis*
12. Shape of signum as in **Figure 1.36c**, particularly characteristic being the small processes directed outwards from the anterior corners; the paired chitinous thickenings situated anteriorly and not continuous medially, sometimes a separated second pair behind the first *schwetzi*
 Shape of signum as in **Figure 1.36i**, no outwardly directed anterior processes; the paired chitinous thickenings situated posteriorly, and continuous medially, so forming a crescent *haningtoni*
13. Signum in the form of the bottom part of a circle, the curved portion directed posteriorly and cut into medially by a V-shaped notch, separating the half circle into two lobes; tends to be very weakly chitinized, so much so in a freshly emerged specimen that it was originally missed when the female genital armatures were described; occupying only a small portion of the genital fossa posteriorly (**Figure 1.36b**) *longipennis*
 Signum not so shaped and occupying most of genital fossa **14**

FIGURE 1.36
Signa of female tsetse of the *fusca* group

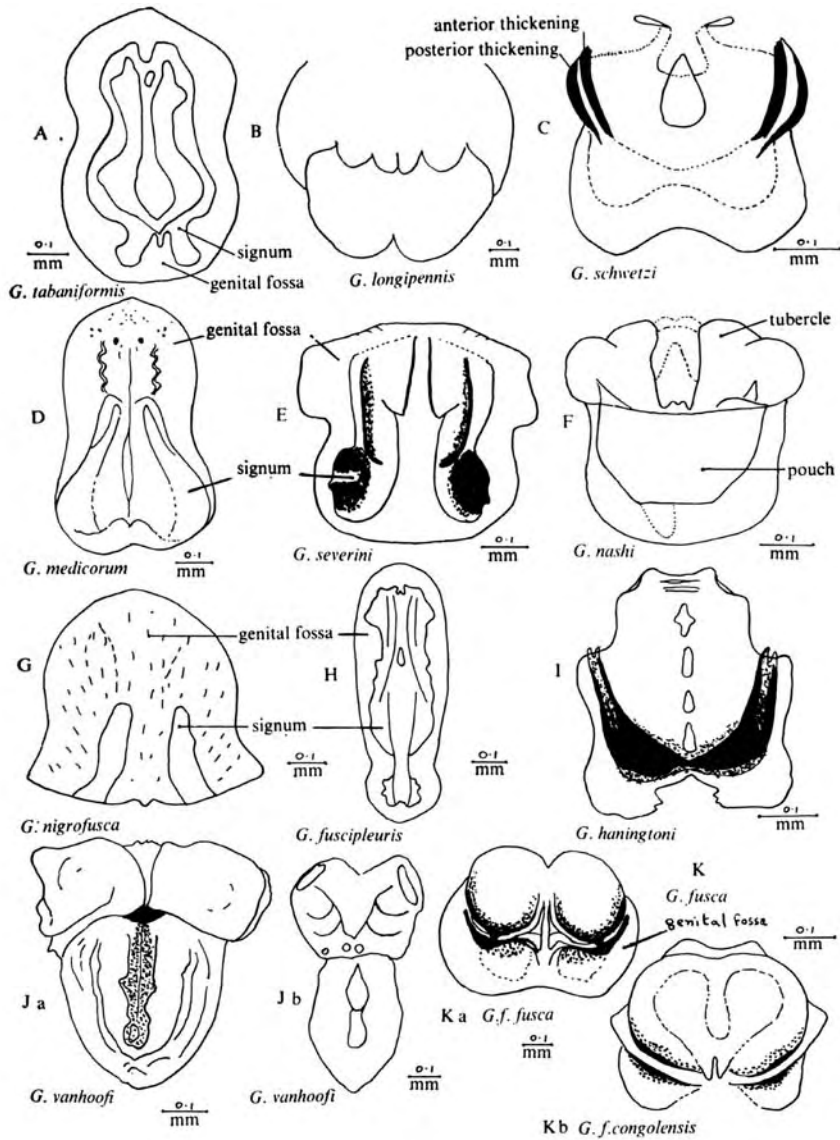

(a) *Glossina tabaniformis*, (b) *Glossina longipennis*, (c) *Glossina schwetzi*, (d) *Glossina medicorum*, (e) *Glossina severini*, (f) *Glossina nashi*, (g) *Glossina nigrofusca*, (h) *Glossina fuscipleuris*, (i) *Glossina haningtoni*, (j(a-b)) *Glossina vanhoofi*, (k(a)) *Glossina fusca fusca*, and (k(b)) *Glossina fusca congolensis*
Source: Mulligan 1970

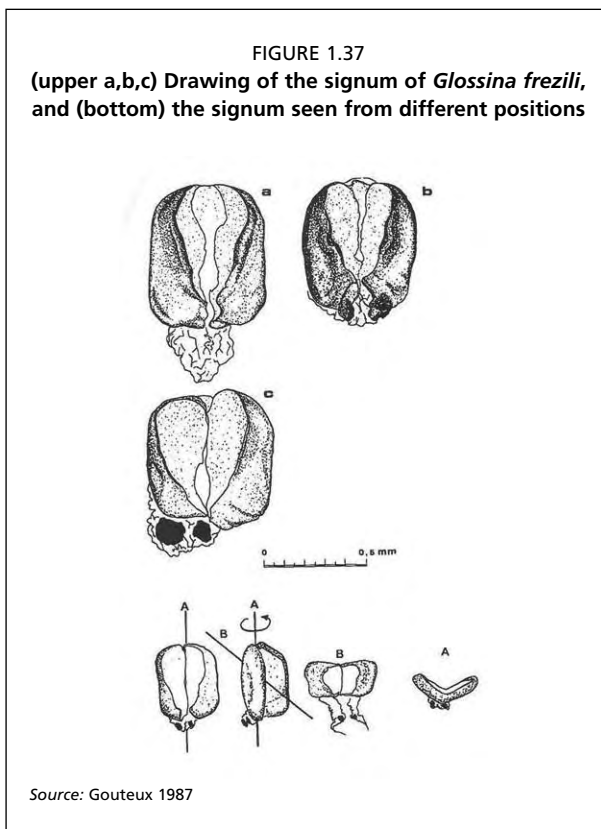

- 14. Signum of uterus with two anterior bilobed tubercles tapering posteriorly into hollow stalks that lead into a sporran-shaped pouch (**Figure 1.36f**) *nashi*
 Signum of uterus consisting of two parts, the upper a hollow lobe capping the lower one, a truncated cone in which there is a median chitinous plate in the form of a spear head with the point directed anteriorly (**Figure 1.36j**) *vanhoofi*

- 15. Median plate of external genitalia broader than tall (**Figure 1.38i**) *caliginea*
 Median plate as tall as broad or taller **16**

- 16. Dorsal plates taller than broad **17**
 Dorsal plates as tall as broad or nearly so **20**

- 17. Dorsal plates nearly twice as tall as broad (**Figure 1.38j**) *tachinoides*
 Dorsal plates never nearly twice as tall as broad **18**

- 18. Dorsal plates extending laterally well beyond width of anal plates (**Figure 1.38e**) *fuscipes quanzensis*
 Dorsal plates not extending laterally beyond width of anal plates **19**

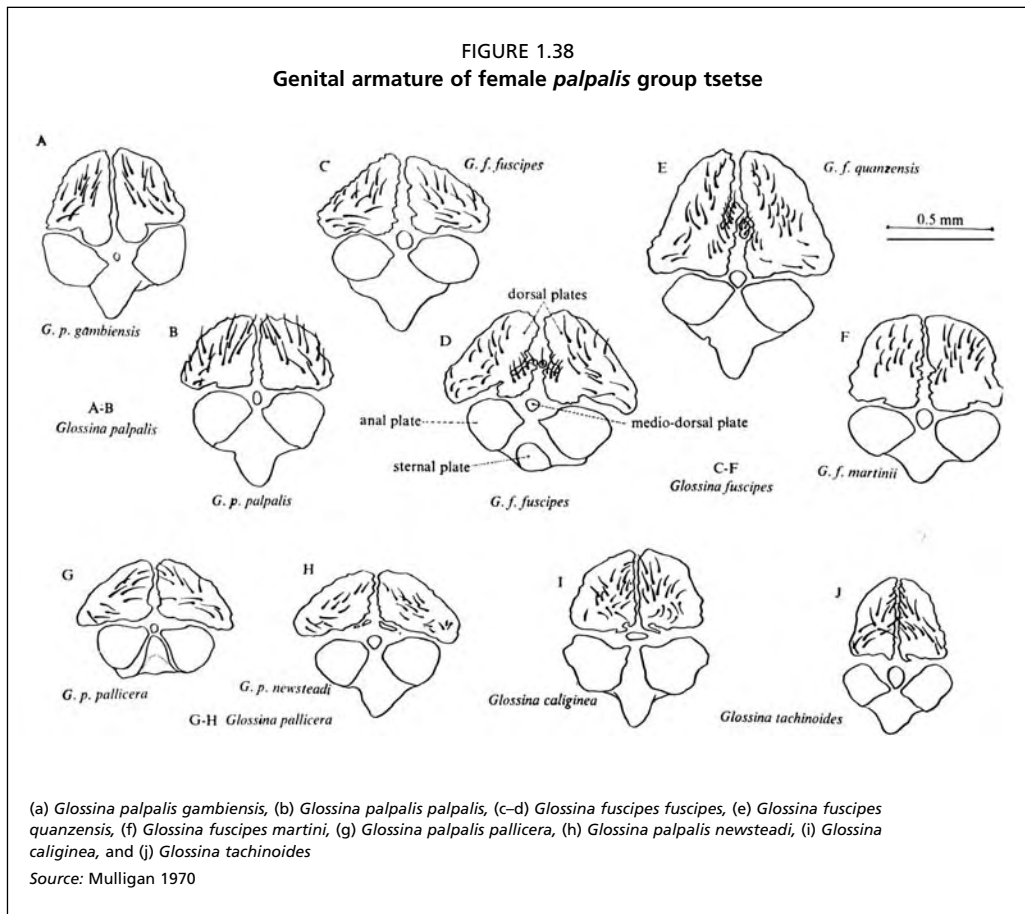

19. Inner angles of dorsal plates projecting markedly downwards below base of plates; median plate very small (**Figure 1.38a**) *palpalis gambiensis*
Inner angles of dorsal plates not so projecting; median plate large (**Figure 1.38f**) *fuscipes martinii*
20. Dorsal plates markedly broader than tall (**Figure 1.38g,h**) *pallicera* s.l.
Dorsal plates about as broad as tall or only slightly broader **21**
21. Dorsal plates very close together; hairs more robust and absent from median space and internal angles (**Figure 1.38b**) *palpalis palpalis*
Dorsal plates comparatively widely separated; hairs less robust and almost always present on internal angles and often on median space as well (**Figure 1.38c,d**) *fuscipes fuscipes*

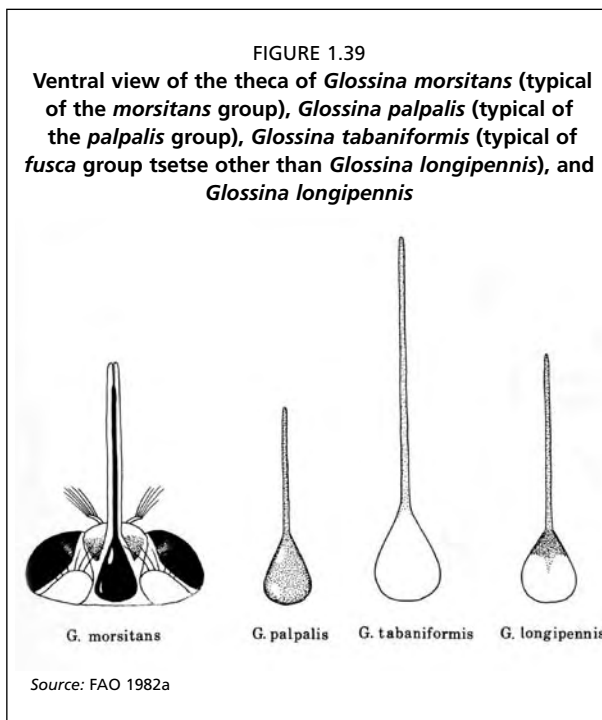

1.5.1.4. Additional Features Useful for Identification

There are a few key features that are used for identification of most species, for example, the superior claspers can distinguish all species of male *morsitans* group flies, the inferior claspers distinguish the *palpalis* group males, whilst the shape of the signa is characteristic of all *fusca* group female tsetse. *Palpalis* group and *fusca* group tsetse are best identified by examination of the genitalia rather than using the key in 1.5.1.1. The females of the *morsitans* group must be identified by use of the key in 1.5.1.1. The females of the subspecies of *G. pallicera* and *G. p. newsteadi* cannot be separated by their external genitalia, but are easily distinguished from each other by external characters (1.5.1.1.). Some species or groups of tsetse can be distinguished by the colour of the thecal bulb (**Figure 1.39**). *Fusca* group tsetse, except for *G. longipennis*, have a very pale brown thecal bulb when viewed from underneath; that of *G. longipennis* has a darker apex, in contrast to *G. brevipalpis*, whilst the thecal bulb of *morsitans* and *palpalis* group tsetse is dark brown or nearly black. This is a useful feature as the latter two species occur in the same habitat.

1.6. GLOSSARY OF TERMS

The terms used here, although apparently obscure words often have precise meanings and are commonly used in botanical and zoological keys.

Apical	At the tip, or apex
Bifid	Divided by a deep cleft into two parts
Bifurcated	Divided into two branches (two forked)

Cordiform	Heart shaped
Distal (distally)	Situated away from the centre, or point of attachment (terminal/ distant)
Dorsal	On the top (back) surface (opposite of ventral)
Fuscous	Dark coloured (sombre)
Glabrous	Free from hair (bristles), smooth cuticle
Hamate	Hook shaped
Infuscation	Darkness
Lyriform	Shaped like a harp (musical instrument)
Median	Situated in the middle
Ochraceous	Pale brownish-yellow colour
Recurved	Bent backwards
Rotund (subrotund)	Rounded (partly rounded)
Setulose	Having small bristles (setae)
Sporran shaped	Pouch shaped
Squamiform	Scale like
Suffusions	A colour spreading out from a central point
Testaceous	Hard continuous shell; of brick-red colour
Truncated	Ending abruptly as if cut off at the tip
Ventral	On the lower surface of the abdomen (stomach)
Vestiture	Hair/scales/bristles covering a surface

Abbreviations

The following abbreviations are for commonly used terms, from the Latin, in zoological or botanical systematics:

- s.l. *sensu lato*, meaning in the broad sense, for example, this could be used for all subspecies of *Glossina fuscipes*
- s.s. *sensu stricto*, meaning in the strict sense; this could be used to refer to just *G. fuscipes fuscipes*, and not the other subspecies

1.7. TSETSE DISTRIBUTION

The ultimate objective of these guidelines is to facilitate the development of baseline data collection strategies that will result in data on tsetse presence, absence, densities, ecology and possibly population dynamics. In that respect, the production of fairly precise tsetse distribution maps is particularly important for AW-IPM approaches. As described in the second section of these guidelines, a starting point at the planning stage is to make use of existing distribution maps to roughly determine the area in which to carry out a survey. Distribution maps are available at the continental level, based on patchy historical data, and clearly not of a high resolution. Maps at the country level are often available that are more accurate, although sometimes of localized accuracy according to where work has been carried out and sometimes out-dated. The latter maps should be readily available within a country. There may often be fairly accurate maps available for specific sites within a country where there have been previous projects; again, these may not be published and therefore not readily available except within a country where they will usually be available

TABLE 1.1.

List of the tsetse species and subspecies that have currently been described.

Scientific name	Authority
Genus <i>Glossina</i>	Wiedemann, 1830
Subgenus <i>Austenina (fusca)</i> group	Townsend, 1921
<i>G. brevipalpis</i>	Newstead, 1910
<i>G. frezili</i>	Gouteux, 1988
<i>G. fusca congolensis</i>	Newstead and Evans, 1921
<i>G. fusca fusca</i>	Walker, 1849
<i>G. fuscipleuris</i>	Austen, 1911
<i>G. haningtoni</i>	Newstead and Evans, 1922
<i>G. longipennis</i>	Corti, 1895
<i>G. medicorum</i>	Austen, 1911
<i>G. nashi</i>	Potts, 1955
<i>G. nigrofusca hopkinsi</i>	Van Emden, 1944
<i>G. nigrofusca nigrofusca</i>	Newstead, 1910
<i>G. schwetzi</i>	Newstead and Evans, 1921
<i>G. severini</i>	Newstead, 1913
<i>G. tabaniformis</i>	Westwood, 1850
<i>G. vanhoofi</i>	Henrard, 1952
Subgenus <i>Glossina (morsitans)</i> group	(Zumpt, 1935)
<i>G. austeni</i>	Newstead, 1912
<i>G. longipalpis</i>	Wiedemann, 1830
<i>G. morsitans centralis</i>	Machado, 1970
<i>G. morsitans morsitans</i>	Westwood, 1850
<i>G. morsitans submorsitans</i>	Newstead, 1910
<i>G. pallidipes</i>	Austen, 1903
<i>G. swynnertoni</i>	Austen, 1923
Subgenus <i>Nemorhina (palpalis)</i> group	Robineau-Desvoidy, 1830
<i>G. caliginea</i>	Austen, 1911
<i>G. fuscipes fuscipes</i>	Newstead, 1910
<i>G. fuscipes martini</i>	Zumpt, 1935
<i>G. fuscipes quanzensis</i>	Pires, 1948
<i>G. pallicera newsteadi</i>	Austen, 1929
<i>G. palpalis gambiensis</i>	Vanderplank, 1949
<i>G. palpalis palpalis</i>	(Robineau-Desvoidy, 1830)
<i>G. tachinoides</i>	Westwood, 1850

in the government department responsible for tsetse and trypanosomosis activities. Older maps are usually available only as hard copies, whilst more recent maps are increasingly available in digital format and as GIS data layers. In addition to the maps based on existing knowledge of tsetse distribution, there are now maps available showing the predicted suitability for tsetse species based on a variety of factors, principally climatic ones, as described

FIGURE 1.40
 Predicted suitability for the *palpalis* group tsetse species

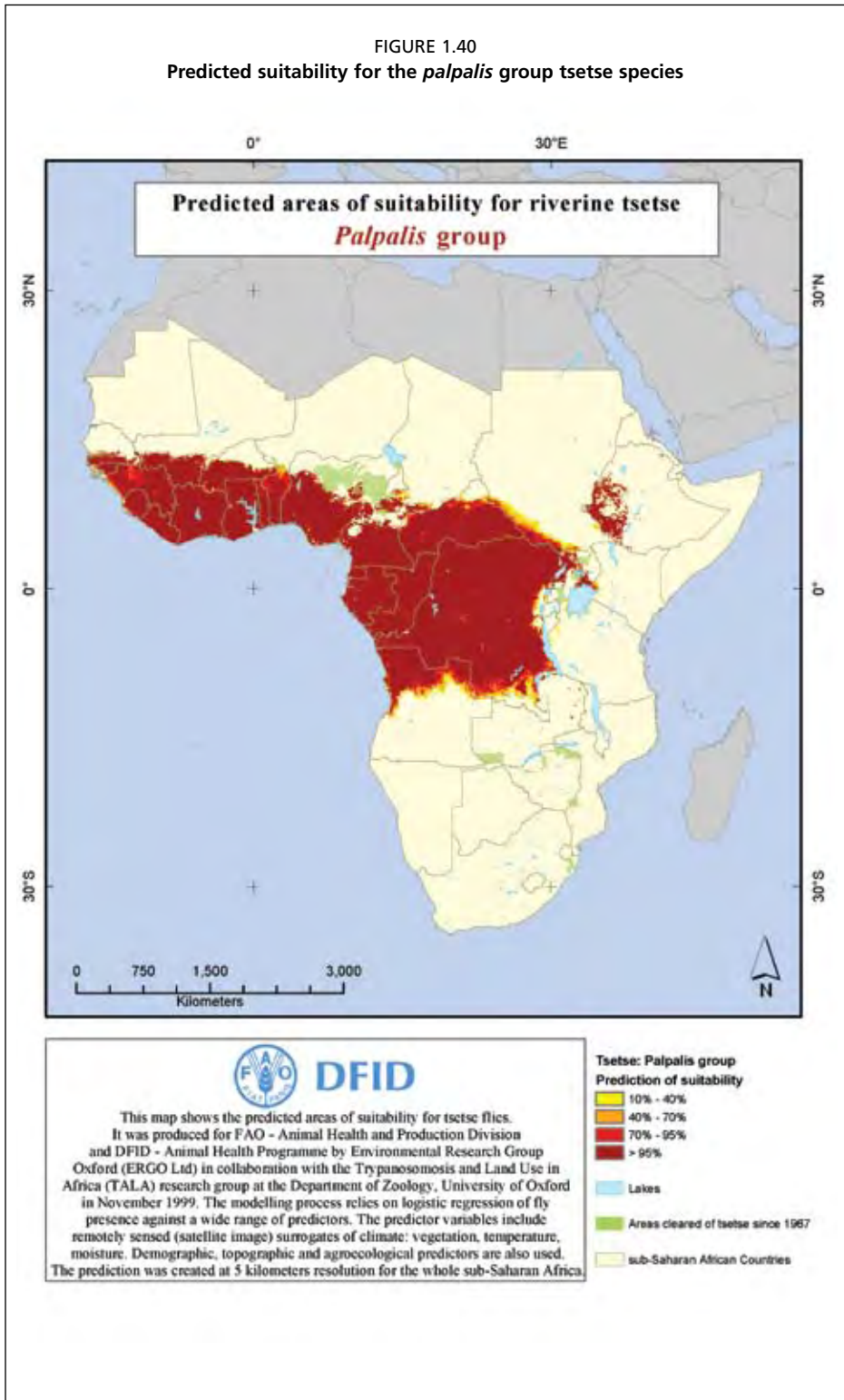

FIGURE 1.41
 Predicted suitability for the *morsitans* group tsetse species

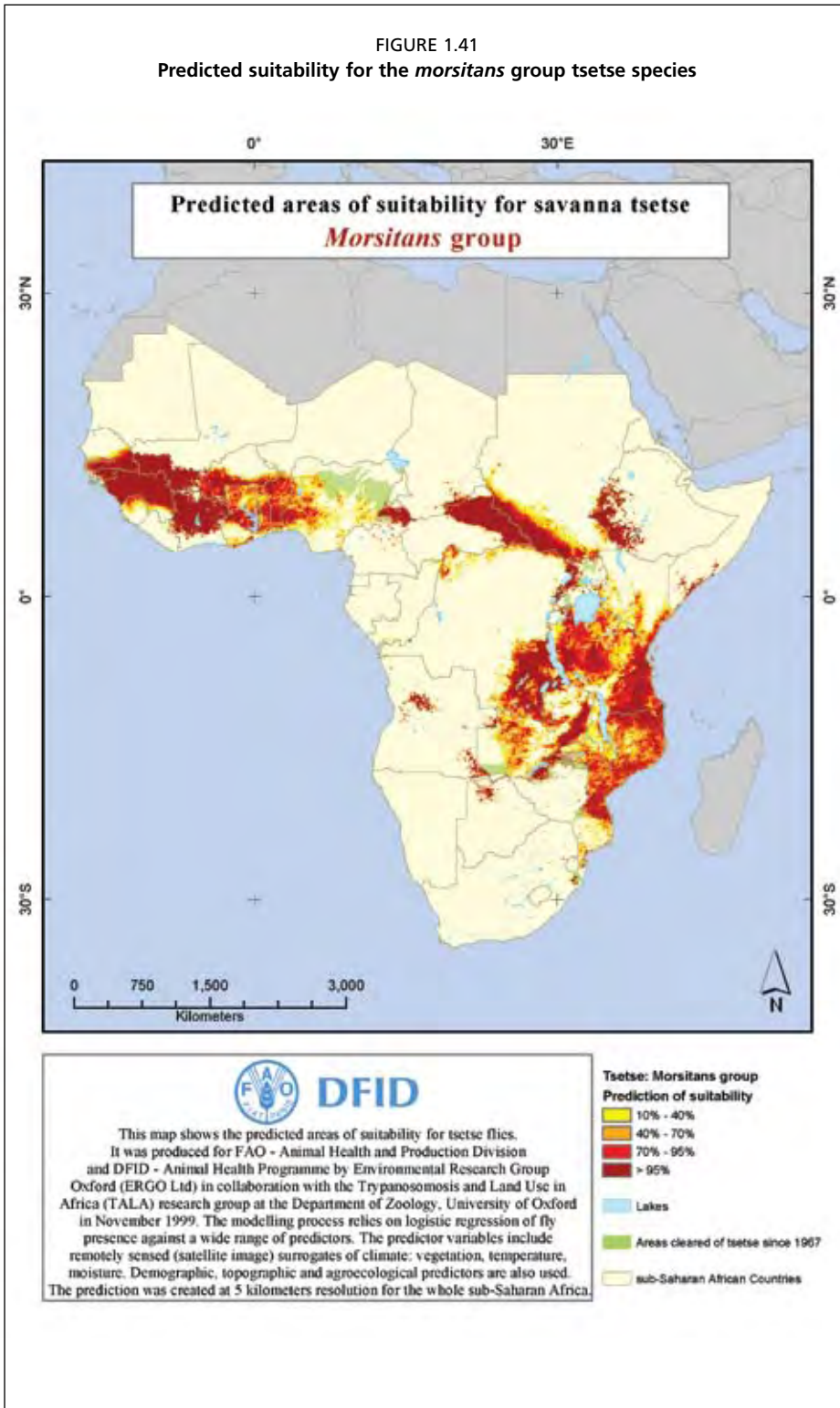
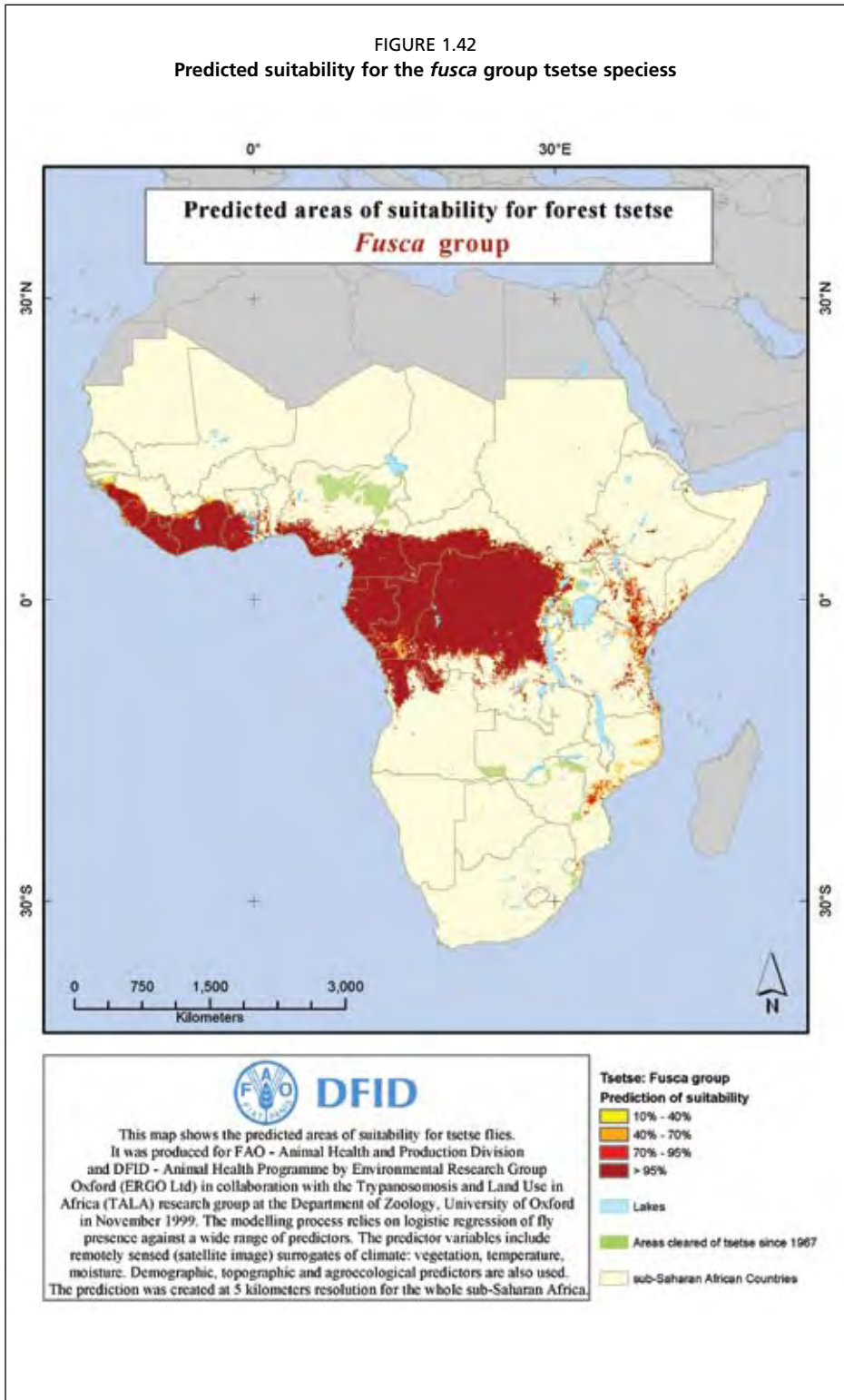

FIGURE 1.42
 Predicted suitability for the *fusca* group tsetse species



subsequently. These predictive maps are currently available at a relatively low resolution for the continent and at a more detailed resolution for some regions. Information is also available in the form of tables listing the known tsetse species in each infested country (Moloo 1985, 1993). These tables and maps will assist in focusing on the areas and target species for any given area prior to detailed surveys.

In the above species list, the names and dates following the name refers to the person who originally gave it its scientific name and the date of that naming. When the name appears in brackets it means that the species has been subject to re-naming after the original description; that may happen when subspecies are identified and named.

The predictive maps referred to above are available on the internet at the following link: <http://www.fao.org/ag/againfo/programmes/en/paat/maps.html>. A selection of the maps available from this site is illustrated in **Figures 1.40, 1.41, and 1.42**. The figures show the predicted suitability for the *palpalis* group or subgenus, the *morsitans* group or subgenus and the *fusca* group, or subgenus, all on a continental scale, respectively.

Section 2

Planning and Preparation of a Baseline Data Survey

2.1. IDENTIFICATION OF A POTENTIAL PROJECT AREA

The first step to be taken is to identify areas that will be suitable to apply the control tactics on an area-wide basis, irrespective whether an eradication or suppression strategy is selected. Site selection will be based on the identification of an isolated tsetse population in a region or a country, for which an area-wide approach would be suitable. Most tsetse-infested areas will extend from one country to another and will therefore require a regional approach, although there may be one or more smaller areas within a single country. Where there is more than one potential site identified, a process of prioritization for area-wide control will be necessary. Prioritization will be carried out using various criteria such as shown in **Tables 2.1** and **2.2**.

A necessary concept to understand regarding AW-IPM is that it is an entire tsetse population that is being targeted, not simply a geographical area from which tsetse are being removed; therefore the area (in terms of numbers of square kilometres) can be very variable. Thus it might vary from an area around 1000 km², e.g. the Niayes area of Senegal (estimated to be approximately 10 km wide by 100 km long), up to a maximum limited by what is feasible from a practical, logistical standpoint (likely to be around 20 000–40 000 km², as in the Ethiopian Southern Rift Valley (STEP) project). In such a large project area, however, the approach to eradication activities will be phased, starting at one side/edge and working in phases across the area until it is complete. It is unlikely that an attempt would be made to undertake activities over the whole area simultaneously. This principle of the “rolling carpet” is fully described and developed in Hendrichs et al. (2005).

2.1.1. Selecting an Area

Predictive maps (**Figure 2.1**) of tsetse presence or absence have been developed covering the whole of Africa for each tsetse species (<http://ergodd.zoo.ox.ac.uk>). The first predictive tsetse distribution maps were developed using discriminant analysis and maximum likelihood statistical techniques. These methods have since been replaced by simpler logistic regression modelling based on the same predictor variables. The predictor variables upon which the modelling is based include data from earlier tsetse distribution maps (Ford and Katondo 1977) supplemented and updated with more recent knowledge including, satellite-derived climatological data (rainfall and temperature and elevation data) and vegetation cover data. The methodology is described in detail in Wint (2001).

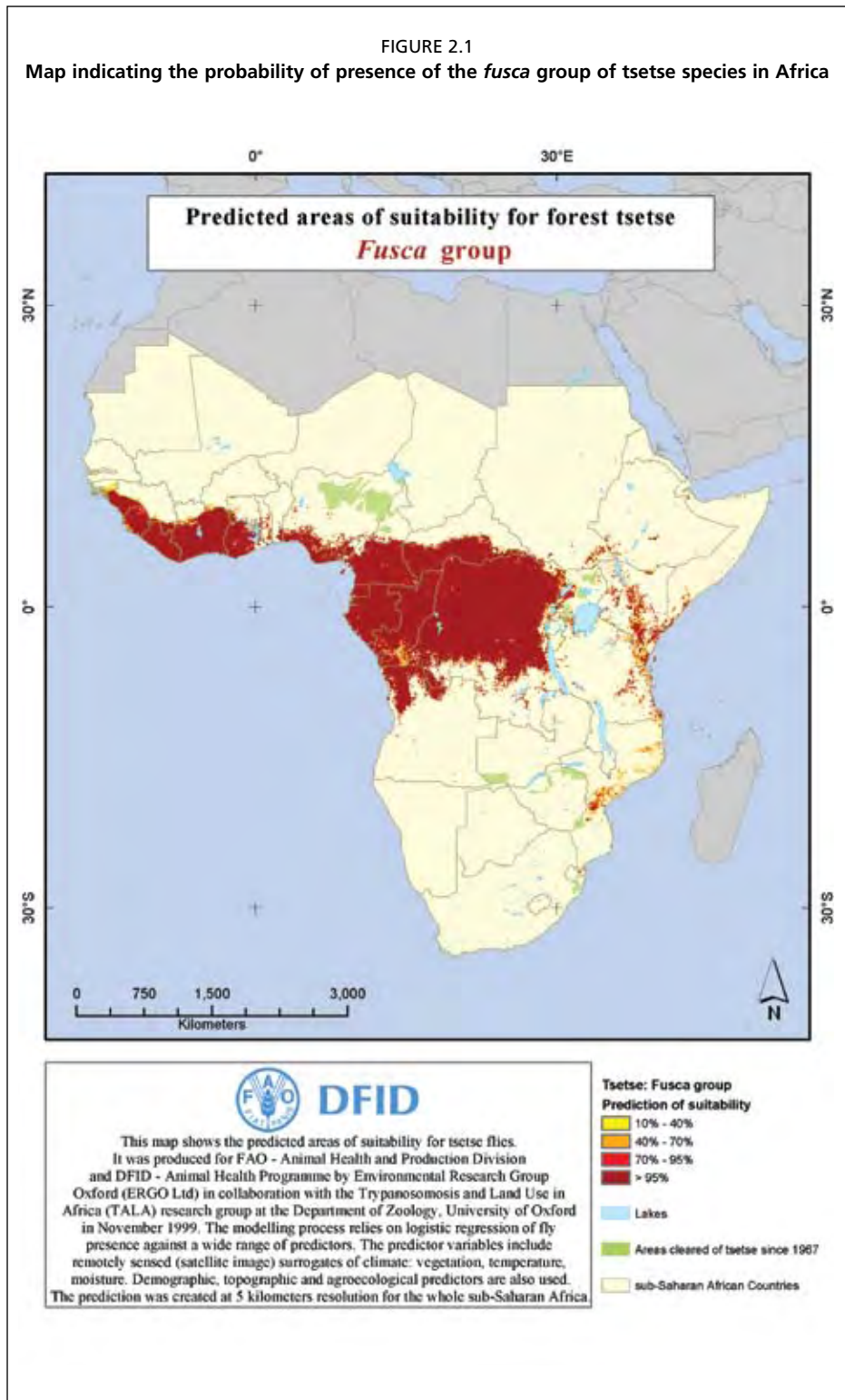

Using predictive maps (Wint 2002, 2003), likely isolated areas of tsetse infestation can be identified. An example is shown in **Figure 2.2, upper**, of a continental scale predictive map for the presence or absence of *Glossina tachinoides*. This map shows a belt stretching across much of the subhumid Guinea zone of West Africa and an additional isolated area of infestation in Ethiopia. The latter could be selected for area-wide eradication, however, the map of this infestation illustrates the limitations of large-scale predictive maps. As they are just predictions and do not provide precise limits of infestation they can only be used as a guide, they are based on the available data and whilst they have been shown to predict presence with a high degree of accuracy, there is still a need for verification in the field. It is improbable that the western edge of the infestation in Ethiopia stops neatly along the border with Sudan, rather, it is likely that imprecise climatological data or vegetation data were available for this border area or that no previous records of presence of *G. tachinoides* were available for Sudan. The predictive map shown in **Figure 2.2, upper** has been super-

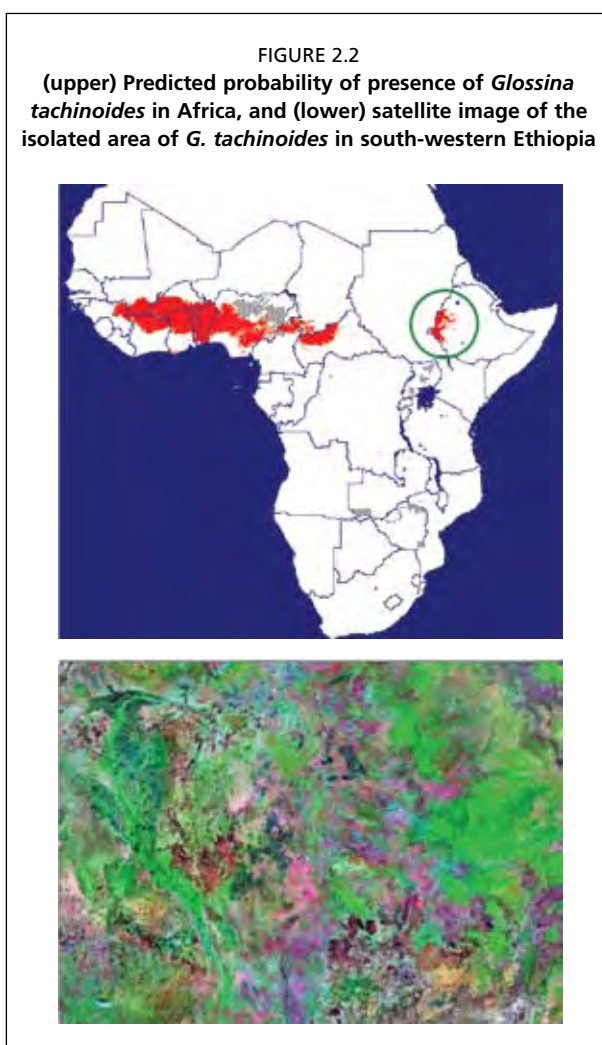

seeded by subsequent predictive maps at a 1-kilometre resolution that are obviously more accurate but are not available for all of tsetse-infested Africa. A satellite image showing the vegetation in the circled area of **Figure 2.2, upper** is shown in **Figure 2.2, lower** and could be used as an aid to determining whether it is likely that the *G. tachinoides* distribution actually extends into the eastern part of Sudan and potential areas that should be surveyed based on that assessment

Having identified the isolated tsetse population, available maps for land use, distribution of livestock, human population, communications infrastructure, etc., will be collated

BOX 2.1

Baseline Survey Data and the Sterile Insect Technique (SIT)

The area-wide pest management programmes for tsetse flies will, in many cases, include the release of mass-reared male sterile flies as a technique for eradication. Population eradication by the release of sterile insects is generally regarded as having three components:

1. the production of sterile insects in sufficient numbers and of adequate biological quality to induce sufficient sterility into the pest population to reduce or eliminate the pest from the treated area,
2. effective distribution of the sterile insects so that the sterile and pest insects interact and inter-mate,
3. the sterile insects are behaviourally and genetically compatible with the pest population so as to be able to achieve matings that induce sterility into the pest population.

The successful execution of these components is dependant to a large degree on features within the area where the programme is to be applied as well as

distances from the sterile insect production site to the programme site. Costs and loss of sterile insect quality during transport has, in many programmes, such as fruit flies and screwworms, been a major factor determining rates of eradication. In many of these programmes, flies have been shipped as irradiated pupae from the mass-rearing facility to dispersal centres (where flies emerge from the pupae and are collected for dispersal) close to the target area. If the sterile release is near to the site of the sterile insect production facility, distance factors may not be important and this will be a positive consideration in site prioritization. If the release site is more distant so that considerable transport times by air or ground transportation are required, ferry costs or costs of procuring, fuelling and maintaining trucks should be considered. If sterile insects are to be transported by ground vehicles to sites for aerial release, airports or air-strips must be available and areas for transferring sterile insects to the aircraft must be available.

Other factors such as monitoring the distribution of the sterile insects and evaluating their quality will be carried out during the monitoring and suppression period of the programme.

and consulted in order to facilitate the survey planning. Communications infrastructure (roads and other means of access) will be particularly important. It is impractical to plan trap deployment in areas that are too inaccessible by road unless the area is very small because too much time would be spent deploying and revisiting traps. A compromise has to be reached between deploying traps in areas very close to roads and human habitation

TABLE 2.1
Criteria/guidelines for prioritizing areas for joint international action against tsetse and trypanosomiasis in the context of sustainable agricultural and rural development (SARD) (adapted from PAAT 2002).

Prioritization Criteria
1. Severity of the impact of the T&T problem
2. Desire/need for intervention by local communities and national governments
3. Opportunity to support poverty reduction, increase food security and maximize socio-economic returns through enhanced sustainable agricultural and rural development (SARD), such as: <ul style="list-style-type: none"> a) Expansion and intensification of mixed farming b) Improved subsistence farming and/or production of cash crops c) Land use and tenure as components of sustainability d) Sustainable and environmentally appropriate utilization of natural resources
4. Factors contributing to increased feasibility and early success of project activities and sustainable outcomes, such as: <ul style="list-style-type: none"> a) Activities phased and initial objectives achievable within 5 – 7 years of a programme/project cycle b) Natural barriers

TABLE 2.2
Criteria for the selection of areas suitable for area-wide integrated pest management (AW-IPM) programmes and means of verification.

	Criteria for selection	Means of verification
Selection of sites based on feasibility for AW-IPM and subsequent prioritization of those sites	Isolated tsetse infestation	Predictive maps
		Existing tsetse distribution maps based on previously conducted surveys
Justification for AW-IPM	Size of the area	Geometrical estimation
	Potential for agricultural/ rural development	Land use maps
		Livestock distribution maps
		Human population distribution maps
	Endemicity of human sleeping sickness	Ministry of health records of reported sleeping sickness cases/prevalence of infection
	Other economic impact e.g tourism	Statistics on tourist numbers and destinations Reports of concerns by tourists – tour operators

that might be poor habitat for tsetse and selecting deployment sites that might be ideal tsetse habitat but cannot be easily reached. The aim should be to be able to deploy and service about 20 traps per day per team within a normal working day. Having selected an area through prioritization criteria, feasibility of carrying out area-wide eradication will be assessed based on additional criteria (**Table 2.1** and **2.2**), on the size of the area, the potential means of tsetse population reduction and their suitability (e.g. is the terrain and distribution of tsetse suitable for aerial spraying with insecticides (sequential aerosol technique (SAT))?) Is the suitability of the habitat such that tsetse may be present but at a low density (due to low suitability of the habitat) to make SIT a more suitable option?)

2.2. OBJECTIVES OF THE SURVEY

The primary objectives of a survey should be carefully considered before the planning phase as they will influence the type of survey and the way it is implemented. The primary objectives of a survey are: (1) to determine the precise distribution and limits of a tsetse population in a given area, (2) to determine all the tsetse species present in the area, (3) to determine the relative abundance (apparent density) of each species present in time and space, and (4) to identify the main ecological niches (habitats) for each tsetse species.

There may be some specific secondary objectives of a survey; for example, it might be useful to monitor other biting flies (Tabanidae, *Stomoxys* spp., etc.). It is known that biting flies are able to mechanically transmit some species of trypanosomes pathogenic to cattle (Leak 1998, Desquesnes and Dia 2004, Hall and Wall 2004). Although traps designed for catching tsetse are not generally efficient for sampling biting flies (exceptions are the Vavoua and NZI traps), they do catch them, and data on catches of biting flies can therefore be recorded. Such catches can be used to assess the potential for mechanical transmission of trypanosomosis, or to assess the impact of suppression techniques such as the use of insecticide-treated cattle on nuisance flies such as *Stomoxys* species that can cause economic losses to livestock production. It is probable that the survey procedures, whatever the objectives, will be refined as a response to data analysis reports, thus, it may be necessary to expand or contract the area surveyed or to concentrate more in certain areas or adopt a different methodology, for example utilization of alternative sampling devices.

The tsetse survey may well be conducted simultaneously with different teams also conducting trypanosomosis surveys of humans or livestock that can provide complementary information on potential vector distribution and disease risk. In addition, socio-economic and environmental surveys need to be undertaken to provide the necessary information for impact assessment studies of any intervention eventually undertaken. Whilst requiring different skills and methodologies, it is desirable that there are links, both in the planning and implementation of these respective surveys as far as possible.

The primary and secondary outputs of the survey(s) can then be used to develop longer-term objectives, for example to: (1) assess the risk of trypanosomosis to livestock and humans, (2) plan area-wide tsetse suppression/eradication, (3) determine which method of population reduction would be most appropriate, (4) plan monitoring of pre-release tsetse population reduction, (5) plan the monitoring of progress of release of sterile male tsetse,

and (6) plan (before tsetse population reduction) the potential land use pattern following tsetse population reduction.

2.2.1. Subsequent Phases

The nature of activities following the initial survey will depend upon the original objectives of the survey; if the objective was to obtain data for a suppression/eradication programme then the survey results will be used to plan the most appropriate approach for population reduction. The most likely scenario following a tsetse survey, planned with an AW-IPM programme in mind, is that it will lead into a monitoring programme involving trapping in a more limited number of reference monitoring sites (RMS) or fixed monitoring sites (FMS) (Vreysen 2000, 2005).

2.2.2. Types of Survey

The broad survey objectives have been outlined above. The more detailed objectives of a survey must also be clearly defined before the sampling technique is decided upon. There is a significant difference between a survey, which is usually an activity carried out once over a period of time in an area, and monitoring, which implies a long-term activity where the population is sampled frequently. Surveys can be divided into the following categories:

Minimal survey — A minimal survey is one that will be carried out once to determine the distribution of a species. There will be no dissection of tsetse to determine trypanosome infection rates or physiological age structure, simply the determination of presence and absence and distribution limits. The objective here is primarily to establish the presence or absence of flies, usually to determine distribution limits rather than the level of abundance. If it involves more than one species, several sampling methods that can be readily and practically implemented may be employed.

Seasonal survey — A seasonal survey will have similar objectives to the minimal survey, but in addition will determine seasonal variations in distribution and abundance by being repeated at different seasons. As a more intensive form of survey, it should include dissection (e.g. ovarian ageing, determination of trypanosome infection rates or possibly mark-release-recapture experiments), all contributing to the planning of subsequent suppression/eradication of the tsetse population. The intensity and location of surveys will depend on the type of suppression/eradication being implemented. For example, if aerial spraying of insecticide is to be carried out, then surveying the interior of the target area will be of little importance; the requirement will be for more intensive survey of the limits of distribution to determine the spray area. If traps are to be used for population suppression then identifying important tsetse habitats within the target area is important.

A survey to be followed by suppression/eradication of a population will lead into a monitoring programme as this is essential pre-, during, and post-suppression/eradication. The implementation of suppression will be influenced by the monitoring results and evaluation of the success of the suppression or eradication will depend on monitoring (Vreysen 2005). Criteria for determining probability of eradication have been identified that indicate the intensity and duration of monitoring required (Barclay et al. 2005, Barclay et al. in

preparation). Unfortunately, adequate long-term monitoring is frequently not carried out because where large areas are involved cost often becomes a major constraining factor. A monitoring system is therefore required that minimizes the cost relative to the actual control measures, yet gives sufficient data to assess whether the control is effective or not (Vreysen 2005). Where traps are used both for control and monitoring, they can indicate areas of re-invasion pressure and those with insufficient trapping densities to achieve the desired result. RMS will be selected largely based on the results of the baseline survey.

2.2.3. Population Dynamics and Behavioural Studies

Studies on population dynamics or behaviour of tsetse undertaken by a separate team or by university or technical college students (providing them with opportunities for useful field research) can be very valuable; providing essential information to increase the efficiency of suppression or sampling methods or to “fine tune” control programmes. A variety of sampling methods may be used to maximize the information obtained; as such studies are usually carried out over a relatively small area with a relatively small input compared to the overall survey. The sampling method used for population dynamics studies should only remove a very small percentage of the individuals if it is not to affect the overall population structure.

2.3. DESIGNING A SAMPLING STRATEGY

2.3.1. Design of a Survey Programme

Whether a survey area is large or small, there will be limitations to the density of trapping that can be carried out within a given time frame, and this requires some selection of where the traps will be deployed. The area can be divided up into grid squares of any given size; commonly these will be 10 × 10 km Universal Transverse Mercator (UTM) grid squares for large areas or one km² squares for small areas (see 2.4.3.1. for more details). Within the grid squares a choice has to be made concerning where precisely to site the traps. In a perfectly uniform situation, such as might theoretically occur in some savannah areas, the selection could be completely random, i.e. based on random selection of geographical coordinates for each of the required number of trap positions. In reality, it is rare to find a large and completely uniform habitat. There will always be areas of woodland, grassland, thickets, cultivation, etc., and there will be differences in distance from water sources (important for *palpalis* group tsetse). It is therefore necessary to adopt some strategy for selecting deployment sites. This strategy will depend to some extent on the objectives of the survey.

It is important at this stage to distinguish between collecting tsetse for laboratory work or estimation of trypanosome infection rate, and sampling to assess the distribution and/or abundance of tsetse in an area. In the former case, the traps are deployed where they catch the most flies. In the latter case a methodical sampling programme must be designed.

2.3.2. General Principles

Because not all the tsetse flies in a population can be counted, aged, sexed, etc., reliance has to be placed on the collection of representative samples (i.e. a selection of sampling

sites that are representative for a larger area). Ideally the absolute population density, the number of tsetse per unit area, could then be estimated. In practice this is often not possible, so instead the relative population density is determined, i.e. the number of flies sampled per section of fly round or the number of flies caught per trap per day. Such measures are then used to compare apparent densities in different localities or at different times of the year in the same locality, to determine seasonal population fluctuations.

Ideally the sampling method would take a fixed proportion of the population, regardless of the vegetation type or the time of year, i.e. the catch would give a consistent indication of the actual number of flies present. However, when the method depends on tsetse being attracted to a man or to a trap, the numbers depend not only on the density of flies but also on their degree of activity and on the attractiveness of the sampling system. The activity of flies depends on environmental factors, on age, and physiological state, so the proportion of the population sampled may not be constant.

The sample may also not be representative of the population composition for the same reason. Certain categories of the population, age groups, hunger stages, pregnancy stages, are more active than others, and respond differently to the sampling methods. Hence samples tend to be biased in favour of certain segments of the population.

2.3.3. Pattern of Spatial Sampling

Many species of tsetse change in their seasonal distribution. Generally, they concentrate in dense vegetation in the dry season and extend into more open areas during the rains. Such seasonal changes in distribution take place not only with savannah species, such as *Glossina pallidipes*, but also with riverine species, for example, *Glossina fuscipes fuscipes* and *G. tachinoides*. In such a situation, sampling must be carried out over the full range of vegetation types that the flies occupy at different times of year. If sampling is only carried out in dense vegetation, there may be a marked decline in apparent density in the rains mainly because the population becomes spread over a larger area.

In order to identify the seasonal changes in distribution, surveys using traps could be carried out either by the method of stratified sampling (see 2.3.5.), repeated for each season, or by systematic sampling in which transects are cut to pass through all vegetation types and traps positioned at regular intervals. For the types of survey described here, in which trapping is carried out at each deployment site for only a few days, the latter method is less appropriate and is more suited to long-term monitoring.

2.3.4. Pattern of Sampling in Time

The next questions to be addressed are how often should sampling be conducted, and for how many days at a time. If the purpose is to determine the presence or absence of flies over a large area, sampling should be carried out at least once during the dry season and again during or immediately after the rains. Sampling should ideally continue for up to one month (but this will depend on the efficiency of the trapping device) at the limits of distribution to be certain of those limits, although a shorter period may be a necessary compromise between theory and practicality; the longer the sampling is continued, the greater the chance of detecting tsetse at low densities. In extreme situations, continuous surveying for over one year has been required to detect low-density populations. A model

developed by John Hargrove, that will indicate the number of trapping days needed with a given number of traps, and a given efficiency of the trap used, to catch one fly in a given area (1 km²) with a certain statistical probability, can provide good guidance in this respect (Barclay et al. in preparation). In such situations the sampling of livestock for the presence of trypanosomes (indirect monitoring (Vreysen 2005)) should also be considered as an indication of whether or not the presence of tsetse is likely.

Tsetse have a relatively slow rate of reproduction, so very rapid changes in the population size of flies are unlikely, unless some unusual intervention occurs such as a bush fire, the introduction of insecticide or sudden invasions of flies. However, catches may vary considerably from day to day or from month to month, depending on fly activity in relation to climatic factors, their physiological state or the availability of hosts. Some factors causing changes in trap catch size (unrelated to population size) remain obscure.

The savannah species, such as *Glossina morsitans* and *G. pallidipes*, are active mostly for the first two hours and the last two hours of the day (Hargrove and Brady 1992). Many of the riverine species such as *G. f. fuscipes* are active in the middle of the day (Crump and Brady 1979). There are exceptions to these generalities: the savannah species *Glossina longipennis* is most active just after sunset (Kyorku and Brady 1994), and *Glossina austeni*, another savannah species, is active in the middle of the day during the cold season and in the early morning and late afternoon during the hot season (M. Vreysen, unpublished). These factors have to be taken into account when planning the time at which traps will be deployed and subsequently checked for caught flies or if alternative survey methods are being used such as fly rounds or traverses with vehicle-mounted traps.

Recent work suggests that sampling once a month for a minimum of three days and ideally for a 7–10 day period enables major changes in density to be detected, and this should be regarded as the minimal level of sampling intensity. The appropriate duration of trapping is described further in 2.4.3.1.2.

2.3.5. Stratification and Stratified Sampling

For a large area, it is unlikely that there will be sufficient human or material resources to survey the whole area in detail. It is therefore necessary to select areas in which surveys should take place. This will require that representative areas to be chosen. If the area was completely uniform in all respects (vegetation, climate, altitude, land use, distribution of human habitation, etc.) then an appropriate number of sampling sites could be selected at random (superimposing a grid of numbered squares over the area and selecting the appropriate number of squares with a random number generator for example). Stratified sampling techniques are generally used when an area is heterogeneous, or dissimilar, but in which, certain homogeneous, or similar, subareas (strata) can be isolated. In these areas, the measurement of interest (tsetse apparent density) is likely to vary among the different subgroups. For example, tsetse habitat is unlikely to be uniform within a large area; there may be areas of forest, cultivated land, riparian forest, grassland and savannah woodland for example. This has to be accounted for when we select a sample from the area in order that we obtain a sample that is representative. This is achieved by stratified sampling. In stratified sampling, a random sample is normally drawn from each of the strata, however, for tsetse surveys the selection of strata for trap deployment may be less random as there

has to be a compromise to achieve a feasible approach. Therefore factors such as accessibility have to be taken into consideration.

When sampling an area with several strata, the proportion of each stratum in the sample is normally the same as in that area. Some reasons for using stratified sampling over simple random sampling are: (1) the cost per observation in the survey may be reduced, (2) estimates of the area parameters may be wanted for each subpopulation, and (3) increased accuracy at given cost.

As it is unlikely that a homogeneous, uniform area will be found, (there will be areas of riverine vegetation, areas of savannah, areas of cultivated land, and an altitude gradient, etc.), it is necessary to choose strata that will have an impact on tsetse distribution and abundance. Two approaches could be taken in this more realistic situation. Firstly, the area could be divided into blocks of sufficient size to have a good chance of containing several of these strata, then within the blocks trapping sites could be chosen for each stratum within the block. Secondly, having identified the relevant strata, the appropriate number of sampling sites could be randomly selected for each stratum. The number of trapping sites for each stratum is then weighted according to various criteria such as suitability of the habitat for tsetse. That would be unlikely to be the main criteria however; more weight might be attached to potential sources of reinvasion such as an area of lower altitude separating two supposedly isolated tsetse infestations, or to the edges of the area where the seasonal limits of tsetse distribution might need to be more precisely determined. There are various statistical methods available for preparing a statistically valid, representative sampling design (Thrusfield 1996) and these must be considered carefully in the planning stage.

2.3.5.1. Vegetation Types

In order to select the appropriate strata, the vegetation types that constitute the important habitats of tsetse have to be considered. Vegetation classification is a difficult area as botanists may classify many different types, and their definitions may vary according to the authority. For this reason, the Food and Agriculture Organization of the United Nations (FAO) is developing a vegetation classification that, it is hoped, will be internationally accepted. This will still have many categories that will be impractical for use by entomologists carrying out tsetse surveys and therefore a smaller number of broad categories have to be used unless detailed studies are planned. An understanding of the main, broad vegetation types will facilitate the correct identification of likely habitats for each of the 31 tsetse species and subspecies. The main tsetse habitats are the savannah woodlands (*morsitans* group), thickets (especially *G. pallidipes*), riverine/riparian (gallery) forests (*palpalis* group), and forests (*fusca* group). There are, however, many variations on these ranging from mangrove swamps (e.g. for *Glossina frezili*), to *Euphorbia* and *Lantana camara* hedges or scrubland on unused farmland, pine tree plantations and citrus or mango orchards. Detailed coverage of vegetation types and their species composition is beyond the scope of this document. The reader is referred to FAO training manual for tsetse personnel, volume 1 (FAO 1982a), and Leak (1998) for more information on tsetse habitats, whilst some general information follows. Vale (1998) gave a comprehensive review of the responses of tsetse to vegetation in Zimbabwe in relation to trapping, the principles of which are likely to be applicable in other regions of Africa. A further difficulty is that some definitions may

vary, for example, a definition of “forest” in East Africa may be quite different from that used in West Africa.

Savannah vegetation is widespread and can take the form of any tropical or subtropical grassland characterized by scattered trees or shrubs, a pronounced dry season, and periodic bushfires. The savannah biome is transitional between those dominated by forests

TABLE 2.3
Suitability of vegetation types for the different groups of tsetse flies.

Category	Vegetation Type	<i>Morsitans</i>		<i>Palpalis</i>		<i>Fusca</i>	
		Yes	No	Yes	No	Yes	No
Peridomestic	Various			•			
Cultivated	Citrus or mango orchards			•			
	Cotton		•		•		•
	Cereals		•		•		•
	Coffee/cocoa plantations			•			
	Vegetation associated with overgrown cultivated areas (e.g. <i>Lantana camara</i> or <i>Euphorbia</i>)	•		•			
Grassland	Natural or improved pastures		•		•		•
Plantations	Pine/casuarina	•					
	Sisal		•		•		•
	Pineapple		•		•		•
	Palm plantations (natural and man-made)	•		•			
Savanna woodland	Subhumid; mopani, miombo, doka: <i>Isoberlinia</i> , <i>Parkia</i>	•		•			
	Semi-arid: <i>Acacia</i> , <i>Combretum</i>	•			<i>G. tachinoides</i>	•	<i>G. longipennis</i>
	Arid: <i>Acacia</i> (thorn savanna)						
Thicket	Semi-evergreen and deciduous trees, <i>Euphorbia</i>	•				•	<i>G. pallidipes</i>
Mangroves				•		•	<i>G. frezili</i>
Forest	Rain forest			•		•	
	Gallery forest: evergreen tree species and deciduous			•		•	

and those dominated by grasses and is associated with climates having seasonal precipitation accompanied with a seasonal drought. The tropical savannahs are generally found in regions dominated by the wet-dry tropical climate. An extensive cover of tall grasses, sometimes reaching a height of three metres, is found in the tropical savannah. Most savannah grass is coarse and grows in tufts with intervening patches of bare ground. Scattered, individual trees or small groves of trees are common. The umbrella shaped *Acacia* spp. tree is a notable species of the savannah biome. In eastern Africa where precipitation is higher, savannah vegetation is maintained by periodic fires that burn back the forest and stimulate the growth of grasses.

Table 2.3 attempts to summarize the main vegetation types that are likely to be inhabited by tsetse, bearing in mind that other factors play important roles in determining whether or not tsetse will be present or absent, and that local variations can create atypical habitats. During periods of civil unrest or economic disturbances important changes can occur, such as the overgrowth of fields cultivated for cotton or coffee, creating conditions suitable for tsetse, whereas when well maintained, those environments would not be so suitable for tsetse flies.

Note: Although a particular vegetation/land use type may be classed as unsuitable for tsetse, this should not be interpreted as meaning that tsetse will never be found in that category, simply that it is not considered as a habitat in which tsetse permanently live and breed. Clearly, at the ecotone between, for example, grassland and savannah or forest, there will be an interface in which tsetse are found, especially when they venture out of their habitat to feed on hosts in the grassland. In the sense that the areas in which the tsetse disperse to feed also form part of the habitat, a wide variety of land use categories would have to be included, but in the context of this table, habitat can be interpreted as breeding areas. Tsetse fly populations are not linked strongly to species of vegetation but rather to the types of environmental condition that those species create. Thus, the link between *palpalis* group tsetse and citrus orchards comes because citrus orchards grown in suitable climatic regions, when irrigated, or within a humid climatic zone, provide the required conditions of shade and humidity. There will also be a requirement for them to be close to an adequate number of suitable hosts. Savannah woodlands also provide shade and humidity, and above all, suitable hosts, although in some areas, in the dry season, conditions become less favourable and tsetse either become restricted to locations closer to water or adopt behavioural patterns to avoid heat and conserve moisture.

2.3.5.2. River Systems

Surveying a river system for tsetse of the *palpalis* subgenus may require a different methodology from that appropriate for savannah or forest species; basing trap selection on a grid system may be somewhat different due to the linear nature of the riverine habitat. If the area is large and 10 km × 10 km grids are used, there may be more than one river system/watershed in the same square, it will be important to determine if there is any flow of tsetse populations between these river systems. It would then be necessary to deploy survey traps in each river system in the square, not just along one of them. When surveying a river system for *palpalis* group tsetse, there is a high probability that if tsetse flies are found along a gallery forest, they will be present, at least seasonally, along the whole length of that

river/stream, unless there is a marked discontinuity in the vegetation. It will therefore probably not be worthwhile expending too much effort trapping intensively along that stream, especially in those situations where the vegetation encountered is becoming denser and more favourable for riverine tsetse flies. It may be tempting for a survey team to walk along a gallery forest putting out traps at the recommended interval in order to complete the daily deployment quota. However, for the reason given above, it will be more productive to move to another gallery forest/river. This may entail a lot of travelling for deployment of a few traps but would provide more valuable data, i.e. a more efficient implementation of the survey. Within a grid structure, therefore, sampling will be more limited than in an equivalent grid square for savannah species and would concentrate on the gallery forest and peridomestic habitats. Particularly for *palpalis* group tsetse, the most important objective of a survey will be to define the limits of the infested area, and to do this the most efficient approach will be to start at the suspected limits of distribution and progress inwards. Another important consideration when surveying *palpalis* group tsetse in West Africa with a view to suppression/eradication is the degree of isolation of one river system/watershed from another. River systems may have their origins in highlands that separate them by a small distance, for example, the Didessa valley river system in south-western Ethiopia, flowing into the Blue Nile (eventually flowing north, into the Mediterranean) is separated by only a few kilometres from the Ghibe/Omo river system that flows southwards into Lake Turkana in Kenya; similarly in West Africa, the Niger River and the Gambia River originate in the highlands of north-eastern Guinea.

2.3.5.3. Accessibility

Sites close to roads and tracks may not be the best sites for catching tsetse at low densities because such sites are likely to be more disturbed by people, and have fewer wild hosts in the vicinity. However, as with many aspects of a tsetse survey, a compromise has to be made between selecting ideal sites for tsetse, possibly several kilometres from the nearest access route for a vehicle and the time taken to deploy a reasonable number of traps in appropriate locations with the available resources. Many areas are of unsuitable terrain for vehicles, e.g. hilly escarpments, valley sides, or difficult to access in the wet season. In such difficult situations the number of traps that can be deployed in a day may then be limited to 10 per day per team (a team consists of around four people — the number required to physically carry the number of traps that can be deployed in the day and should include one person with good training and experience in trap deployment).

In other areas, e.g. the Nguruman area in Kenya, the terrain may be flat (the escarpment at Nguruman is an exception but was not included in routine monitoring and other tsetse work carried out by the International Centre for Insect Physiology and Ecology (ICIPE) in the 1980s). The Nguruman area is also dry for nearly all the year and there are many tracks, as a result of which, vehicles could easily be used for assisting with the deployment of traps and a larger number could be deployed and checked in a day. It takes a lot longer to deploy traps, selecting a suitable site, clearing surrounding vegetation, erecting the trap, than it does “to harvest” the flies or to dismantle the trap at the end of a trapping session. However, since repeated seasonal surveys (or monitoring) are carried out at the same fixed sites, it is the initial deployment that takes longest.

2.3.5.4. Altitude

Tsetse distribution is limited by altitude, due to the cooler temperatures found at higher altitudes. The altitudinal limit will vary with distance from the equator. In Ethiopia, the limit is variable according to season and tsetse species but is between 1600 and 2000 m for *G. pallidipes* (it has apparently increased in altitude over time, possibly due to global warming or vegetation/land use changes (Vreysen et al. 1999)). Altitude may be included in the list of strata for sampling if appropriate.

2.3.5.5. Density and Distribution of Human Population

In some circumstances the distribution and abundance of the human population may be of interest, for example, where surveys are being conducted in relation to the occurrence of human African trypanosomosis (HAT) or sleeping sickness. In such cases it may be necessary to identify areas of human/fly contact for targeted intervention. Such places would include bathing places, washing places, points used for boats, either for fishing or transportation of humans and cargo. In other situations large aggregations of people might render the habitat unsuitable for tsetse and fewer survey traps would be deployed (exceptions might be where the areas of human habitation are on or near the limits of infestation that need to be defined with some precision). Tsetse flies can also occur near or in large cities, e.g. Stanley Pool area of Kinshasa (Democratic Republic of the Congo), zoological gardens in Dakar (Senegal), and Brazzaville (Republic of Congo).

2.3.5.6. Density and Distribution of Cattle Population

Depending upon the purpose of the survey, it may be necessary or useful to take into account the distribution and abundance of cattle/livestock, e.g. if a survey is being carried out for the purpose of assessing disease risk (African animal trypanosomosis (AAT)) to livestock. Watering places of cattle and overnight guarding places (kraals, etc.) would be among the places where traps would be deployed, it might also be necessary/of interest to determine the main seasonal grazing areas of the livestock (Rawlings et al. 1993). A survey of trypanosomosis infections in cattle may be useful in some circumstances to suggest whether tsetse may or may not be present in an area.

2.3.5.7. Seasonality

As referred to in 2.3.3, with respect to the pattern of spatial sampling, there can be significant changes in distribution of tsetse populations between seasons. It is therefore necessary to determine the dry and wet season and/or hot and cold season distribution limits. For this reason a survey should ideally be repeated at each season (as was the case in the survey carried out in the Southern Rift Valley of Ethiopia (see 3.5.2.)). If this is not possible for financial or logistical reasons, it may be possible to correct the data obtained for one season, using the method described in 2.4.3.2. However, this is only possible if some long-term data exists for the area that can be used for calculating the correction factor. This will not provide information on changes in distribution; if a survey can only be done at one season, it should therefore be planned for the season at which tsetse are likely to be most widely dispersed so that the maximum extent of their range can be estimated.

2.3.5.8. Population Genetics

The genetic characterization of tsetse populations can have great importance for tsetse suppression and eradication, for example, it is possible to determine if two adjacent populations are really isolated from each other or if there is gene flow between them. This will have major implications regarding the delimitation of the control area or the need to put barriers in place to prevent reinvasion. Techniques are now available to characterize genetics of tsetse populations and these are described in 3.3.

2.3.6. Meteorological Data: What Climatic Data Should Be Recorded?

Collection of basic meteorological data will allow better interpretation of survey results. For example, the relationship between apparent tsetse density and rainfall, relative humidity and temperature can be determined for understanding of seasonal effects, whilst daily rainfall information will contribute to understanding daily variability in trap catches that is not related to density or distribution, but to activity patterns (most tsetse tend to be inactive during periods of heavy rainfall).

The basic parameters that should be collected are: (1) daily rainfall, (2) maximum temperature, (3) minimum temperature, and (4) relative humidity.

Rainfall distribution can vary over quite small areas, but a single meteorological data collection station will be sufficient for most survey purposes unless there are specific requirements for more detailed observations. Data can be collected using standard meteorological data equipment (e.g. Stevenson screen and rain gauge) although more sophisticated automatic weather stations are now available. If a future aerial spraying programme is envis-

TABLE 2.4
Minimum requirements for a climatological station.

Element	Range	Resolution	Accuracy	Remarks
Maximum temperature	-30 °C to +40 °C	0.1 °C	0.5 °C	daily
Minimum temperature	-30 °C to +40 °C	0.1 °C	0.5 °C	daily
Rainfall	0 to 999 mm	0.2 mm	0.2 mm < 4 mm 5% > 4 mm	daily
Relative humidity	1% to 100%	0.1%	5% below 50% 2% above 50%	
<i>Additional elements</i>				
Element	Range	Resolution	Accuracy	Remarks
Air temperature	-30 °C to +40 °C	0.1 °C	0.3 °C	1 minute mean
Soil temperature	-30 °C to +40 °C	0.1 °C	0.3 °C	
Wet-bulb temperature	-30 °C to +40 °C	0.1 °C	0.3 °C	
Wind direction	10 to 360°	10°	10°	hourly modal
Wind speed	0 to 150 kn	1 kn	1 kn or 5%	1-minute mean
Sunshine duration	0 to 24 hours	0.1 hour	0.3 hour	daily

aged, then soil temperature may be a necessary parameter to measure for more accurate determination of the duration of pupariation.

Observations should be made each day of the year by a competent observer, preferably at the same time each day and instruments should be of a standard design, and should be set up on generally level ground away from obstructions like fences, plants, trees and buildings. The site should be representative of its general location and be sufficiently durable to last for the duration of the project.

2.4. PREPARATORY PHASE

AW-IPM for tsetse flies cannot be successfully planned and implemented without a survey to collect essential baseline data. The importance of the initial planning phase to the successful implementation of such a tsetse suppression/eradication project cannot be overemphasized. Whilst seemingly obvious, this very often does not happen, partly because project funding is frequently of a limited duration, typically a maximum of five years and as soon as project staff is recruited/assembled, there is pressure on them to start implementation of the suppression phase as soon as possible. Furthermore, there are few purely tsetse suppression/eradication projects and most projects will most likely be associated with rural development or human African trypanosomosis (HAT) outbreaks, and therefore, there will be additional activities to prepare and implement at the same time as a tsetse survey. It is therefore appropriate to give attention to the following steps that are necessary in the planning of a tsetse survey.

2.4.1. Area Identification

The first step is the selection of a tsetse-infested area in which an area-wide suppression/eradication programme is proposed, requiring the survey to take place. This area will normally have been determined by a regional coordination meeting comprising representatives of national governments of the countries involved, or, in the case of areas of infestation that do not cross international borders, representatives of the national and local government. The area will have been selected using criteria such as high potential for agriculture and livestock production (**Table 2.1**) (high rainfall area); relative isolation of the tsetse infestation with a limited number of tsetse species; or it may have been selected in response to an epidemic of trypanosomosis (animal or human) or the need to resettle human populations. Predictive and known distribution maps will be very important in selecting, and determining the limits of locations suitable for AW-IPM.

Assuming that technical specialists have assessed that the area is suitable for the proposed suppression/eradication interventions, the next step is to define the limits of the area.

2.4.1.1. GIS as a Planning Tool

A geographic information system (GIS) offers a powerful collection of software tools, instruments (global positioning systems - GPS) and techniques to manage and display data when at least part of the data contains a location component. Using GIS we can merge together and present data on maps in a clear and graphically powerful manner. GIS software such as Arcview® and ArcGIS® can read data or convert files from a wide variety of sources.

2.4.1.2. Preparation of Maps of the Area

To initialize the GIS capabilities for use in a tsetse control programme, a collection of base layers or maps must be obtained. These base maps are computer files in a format which GIS software uses, such as the popular shape file. Some layers are available freely from various sources, e.g. ESRI world maps, Africa data dissemination service, and digital charts of the world (basic maps that are freely available on the internet, but the borders of these maps are not always precise).

Accurate maps are often available from various sources within a country such as the government survey office. These may include land use/vegetation cover, detailed information on human habitation and road or communications networks, rivers and administrative boundaries. If digital formatted maps are lacking then printed topographic maps at scales of 1:50 000 can be scanned, and "registered" to appear in their proper location in a GIS programme. Obtaining hard copies of topographic maps at the 1:200 000 or 1:50 000 scales can sometimes be difficult, especially in countries involved in conflicts, requiring bureaucratic procedures to be followed.

In contrast, satellite images can be obtained commercially over the internet and can be invaluable for identifying potential habitats, vegetation and land use mapping. Some of the satellite imagery is available at low cost, or for free at one kilometre or 30-metre resolution. Higher resolution images, with a 10-metre or finer resolution are more expensive and are required for projects of small scope.

Other maps should also be obtained, if available, for land use/vegetation, habitation, previously determined tsetse distribution and human and livestock distribution and abundance. If possible such maps should be obtained as data files in a GIS format. Otherwise, digital files should be prepared by scanned and registering hard copy maps. The International Atomic Energy Agency (IAEA) commissioned a project for creating a data set of predicted tsetse distribution from the Environmental Research Group Oxford (ERGO). In May of 2003 dataset of predictive distribution layers was completed, and the GIS files are supplied by IAEA on CD for all African countries covered by the project and for all species of tsetse. While the maps can be viewed on the web (<http://ergodd.zoo.ox.ac.uk/tseweb/distributions.htm>) the GIS data files themselves are supplied on request from IAEA. Finally, other layers can be added by utilizing a GPS instrument to locate and trace out features in the field that are not available from other sources (see 2.4.2).

TABLE 2.5
Map scale and satellite imagery in relation to project size.

Size of project	Preferred map scale	Source of satellite imagery
Up to 1000 km ²	1:50 000 minimum	LandSat, Quickbird, SPOT
1000 km ² –4000 km ²	1:250 000	SPOT, LandSat
Above 4000 km ²	1:100 000 or smaller	LandSat

FIGURE 2.4
ArcView® GIS image of a map in western Gambia, displaying tsetse fly apparent densities (no. flies per trap per day) by a colour map

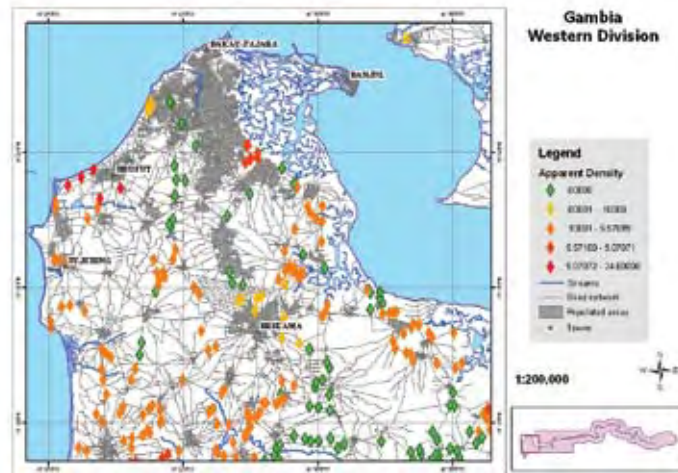
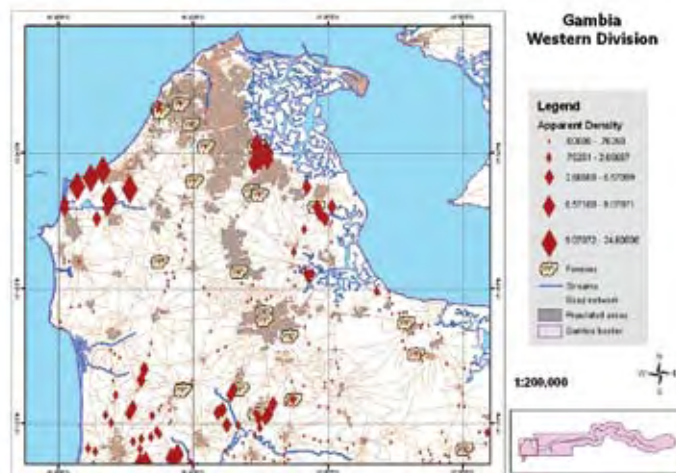
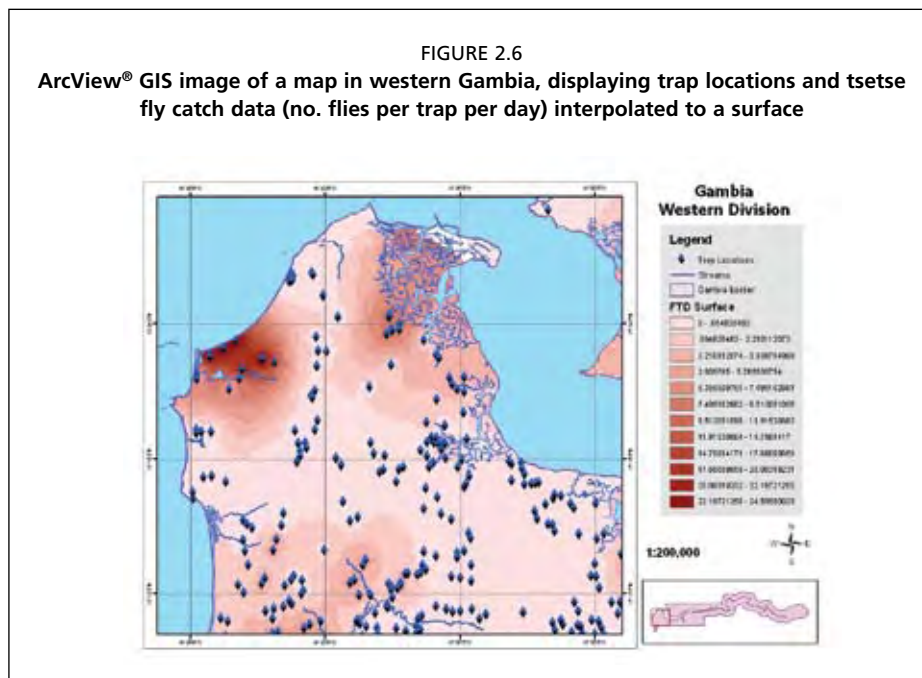

FIGURE 2.5
ArcView® GIS image of a map in western Gambia, displaying tsetse fly apparent densities (no. flies per trap per day) by graduated symbols





in **Figure 2.5** by using graduated sizes of symbols. This facilitates the identification of areas of high and low tsetse density, which is usually linked closely to trypanosomosis risk and by including the data layer for vegetation types (not shown here for clarity), associations can be made between those vegetation types and favourable tsetse habitat; such data can be important in planning the suppression or eradication of a tsetse population. GIS software also incorporates tools for interpolating observed data to neighbouring areas (e.g. grid squares from which no data were obtained). Using this method, observations at a collection of points can be averaged over the whole region to obtain a “surface” representation of tsetse infestation. From this surface, contour lines of level of infestation can be calculated. **Figure 2.6** shows average tsetse infestation over the whole region as a surface coloured darker shades of red for higher levels of tsetse population.

2.4.1.4. Satellite Imagery

Standard 1:50 000 scale maps normally have very basic information, if any, regarding land use and vegetation. As it is of great importance for surveys of almost any insect to know the locations of its preferred habitats, detailed spatial information on vegetation is required.

Ecological requirements and habitat types for tsetse species have been widely studied, providing information that can be used in conjunction with satellite images to determine appropriate trap deployment sites (Leak 1998). Sometimes vegetation maps are available for an area, but very often they are not, or they are out of date. Previously, aerial photographs have been used to identify areas of tsetse habitat and for planning of suppression or eradication. However, aerial photography is expensive and can be difficult to handle and

satellite images are now available to provide an economic alternative for photographs, with the advantage of being easy to manipulate using computers.

Satellite images of an adequate resolution can be used to reliably identify suitable tsetse habitats provided there is some basic knowledge available for their interpretation. Remote sensing image analysis is beyond the scope of this manual, but with some GIS expertise it is also possible to prepare land use/vegetation maps from these satellite images. Satellite images are now more readily available and cheaper than previously and some may be obtained free of charge (e.g. 1-km resolution LandSat 5 or LandSat 7 images, and under certain circumstances, European Système Pour l'Observation de la Terre (SPOT) 4 vegetation images). The older, 1-km resolution, LandSat 5 and LandSat 7 satellite images, currently dating from 1999–2000, are likely to be adequate for many tsetse survey purposes unless it is known that significant land use changes have taken place. Higher-resolution (< 30 metres) satellite images will give a much more precise indication of tsetse habitat. Sources of satellite images, and links to suppliers are given in annex 1.

Satellite images and savannah tsetse species — The satellite image of a savannah area in **Figure 2.7** shows a less clearly defined habitat (*G. morsitans*) in which it would be more difficult to define the sampling area. However, within that image, using predictive (probability of presence) maps (ERGO) an isolated area of tsetse infestation can be identified (circled). This area is surrounded by a natural barrier (Lake Malawi) on the eastern side and unsuitable habitat (a high altitude escarpment) on the western border. Savannah

FIGURE 2.7
**Satellite image of savannah woodland in Malawi
indicating an isolated tsetse area (circled)
bordering Lake Malawi in the east and a high altitude escarpment
in the west**

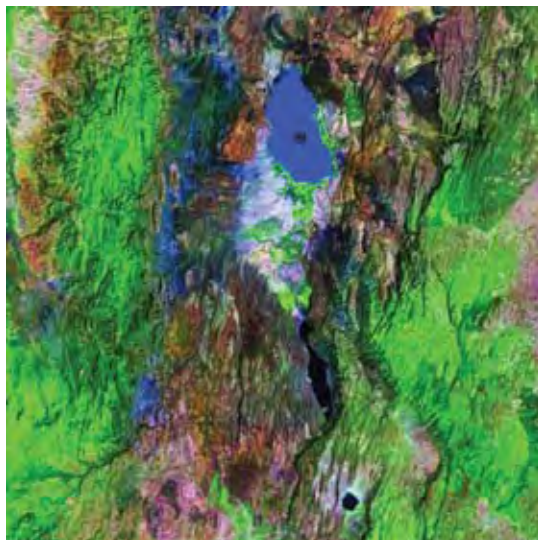

FIGURE 2.8
Satellite image displaying a typical Guinean forest zone in West Africa



NASA

FIGURE 2.9
Satellite image of the Lake Baringo (blue lake, upper part of the image) and Lake Bogoria (black lake, lower part of the image) area in Kenya selected as a possible site for eradication of *Glossina pallidipes*



NASA

areas of East and southern Africa, such as the miombo and mopane woodland, dominated by *Brachystegia* spp. and *Colophospermum mopane*, respectively, tend to be quite extensive, as can the central Africa rain forest, resulting in situations requiring a rolling carpet approach and the establishment of temporary barriers (except where lakes and regions of high altitude are natural barriers to the tsetse distribution).

Satellite images and forest tsetse species — The satellite image shown in **Figure 2.8** shows a much more uniform forest habitat typical of West or Central Africa, with few characteristic features other than a river, some villages and areas of cultivation. Inhabited by a variety of tsetse species (forest and riverine), such an area can only be tackled using a rolling carpet approach (Hendrichs et al. 2005) because it is unlikely that there would be a clearly delineated area of infestation by a single tsetse species, of a size that could be contemplated for such an activity.

2.4.1.5. Interpreting Satellite Images

Satellites provide information on land cover and condition because features of the landscape such as bush, crop, salt-affected land and water reflect light differently in different wavelengths. Satellites carry instruments that detect and record the reflected energy. The detectors are sensitive to particular ranges of wavelengths (“bands”) and satellites are therefore characterized according to the related parameters (see box 2.3 for details).

Sensors in satellites detect the amount of electromagnetic energy reflected by (or emitted from) objects on the earth’s surface. For vegetation, the percent reflectance in the green region is not as high as in the near infrared. This is why false colour or infrared images are

BOX 2.2

Satellite Images

Satellite imagery has been available since the start of the LandSat programme in 1972. The LandSat project is a joint initiative of the United States Geological Survey (USGS) and the National Aeronautics and Space Administration (NASA) to gather earth resource data using a series of satellites. LandSat’s Global Survey Mission aims to establish and execute a data acquisition strategy that ensures repetitive acquisition of observations over the earth’s land mass, coastal boundaries, and coral reefs; and to ensure the data acquired are of maximum utility in sup-

porting the scientific objectives of monitoring changes in the earth’s land surface and associated environment. At the time of printing of these guidelines, LandSat 7 images cost USD 250 per scene.

The Enhanced Thematic Mapper Plus (ETM+) is a multispectral scanning radiometer that is carried on board the LandSat 7 satellite. The sensor has provided nearly continuous acquisitions since July 1999, with a 16-day repeat cycle.

The SPOT 4 satellite, managed by the European Union specifically provides vegetation data that is becoming much more readily available (e.g. <http://www.vgt.vito.be>).

BOX 2.3**Remote Sensing and Satellite Images: Wavelength (“bands”) at which Reflected Energy is Measured**

The LandSat TM satellite has bands at the blue, green and red wavelengths in the visible part of the spectrum, three bands in the near and mid infrared part of the spectrum and one band in the thermal infrared part. The satellite detectors measure the intensity of the reflected energy and record it as a number between 0 and 255.

The size of the footprint (pixel) for which satellites measure reflected energy

The “footprint” or pixel size is the smallest area on the ground for which the detector can record the reflected energy. For every 30 m by 30 m plot of land, the LandSat TM scanner records a number for each of the seven bands, which is the average intensity of the reflected energy for the features in that plot of land.

The frequency with which satellites revisit a particular location

A third feature that characterizes a satellite system is the frequency with which it revisits a particular location. The LandSat TM satellite revisits each location every 16 days. Each image is routinely archived. Theoretically, a site could be viewed every 16 days to detect changes in land use or condition. In practice, some of these images are unusable because the satellite sensors cannot see through clouds.

The goal of image processing is to detect features and changes in those features over time, and to be sure that what is seen is related to the ground cover rather than to interference caused

by the atmosphere. To do this, sequences of images are aligned to each other and to standard map grids (registration and rectification) and are calibrated to remove the effects of atmospheric differences.

Satellite images consist of numbers; the measurements of the amount of energy that has been reflected from the earth’s surface in different wavelength bands. Some of these bands, such as the infrared bands that contain much information about vegetation growth and condition, can’t be seen with the human eye. To convert data into pictures that show changes in reflected energy, the data are represented on a computer screen, or on a hardcopy print, using visible colours. The numbers recorded for the different satellite bands are displayed in red, green and blue “colour guns” on a computer screen.

Although the satellite can record intensities between 0 and 255, typically the actual intensities associated with the ground covers present in agricultural images occupy a much smaller range of values. “Image enhancement” is the term for the process of assigning the range of digital numbers in an image to the computer colour levels.

Different image enhancements can be used to highlight different detail in an image. For example, the minimum image intensity could be set to colour level 0 and the maximum set to colour level 255. This would maximize the number of colours on the computer screen and show some information over the whole image. Alternatively, the range of image intensities corresponding to just remnant vegetation could be assigned to the 256 colour levels, highlighting the detail in the image about remnant vegetation at the expense of other cover types in the image.

used instead of true colour images when sensing vegetation. The uniqueness of satellite remote sensing lies in its ability to show large land areas and to detect features at electromagnetic wavelengths that are not visible to the human eye. Data from satellite images can show larger areas than aerial survey data and, as a satellite regularly passes over the same plot of land capturing new data each time, changes in the land use and land cover can be routinely monitored.

To compose a satellite image the data on wavelengths are converted to colours (red, green, and blue), used to make combinations (see box 2.3) that can be seen on an image. When the red, green and blue bands of an image are assigned to the same colours on the computer screen, a true-colour image is formed. These images look like aerial photographs, since they indicate the true colours of objects – green trees and grass and brown soil. When mixtures of the visible and infrared bands are assigned to the red, green and blue colours on the computer, false-colour images are formed. In these images, the different colours on the screen represent different intensities in the wavelength bands that are assigned to each screen colour. The human eye distinguishes changes in red better than in blue or green, so the band mostly strongly related to the feature of interest is usually assigned to the red colour on the screen.

Grass looks green because it reflects green light and absorbs other visible wavelengths. This can be seen as a peak in the green band in the reflectance spectrum for green grass. Grass reflects even more strongly in the infrared part of the spectrum as can be shown by infrared sensors on the satellite that detect this part of the spectrum.

2.4.2. Georeferencing

2.4.2.1. Global Positioning System (GPS) Instruments

In order to be able to accurately map the results of a survey and to be able to see precisely which areas have been surveyed and which have not, it is essential to know the positions of traps or other sampling devices. By identifying topographical features and in conjunction with maps and sometimes using compasses, it is has been possible, with some difficulty to identify more or less where sampling devices have been situated. Since the 1980s, a much more precise means of identifying locations on the earth's surface (of traps, for example) has been possible by using small instruments known as global positioning system (GPS) instruments. The Global Positioning System (GPS) (boxes 2.4 and 2.5) is a satellite-based radio navigation and timing system developed and operated by the United States Department of Defence. The system permits land, sea, and airborne users to instantaneously determine their three-dimensional position (latitude, longitude and altitude) within less than one metre, velocity (within a fraction of a kilometre per hour), and time (calculated within a millionth of a second) 24 hours a day, anywhere in the world.

2.4.2.2. Initialization, Data Collection and Waypoints

When the GPS instrument is switched on for the first time it has to be initialized: that means it has to be given some information of approximately where in the world it is. This can be done by selecting the country from a list (**Figure 2.10, left**) or by putting in approximate latitude and longitude value. This will speed up the processing and finding

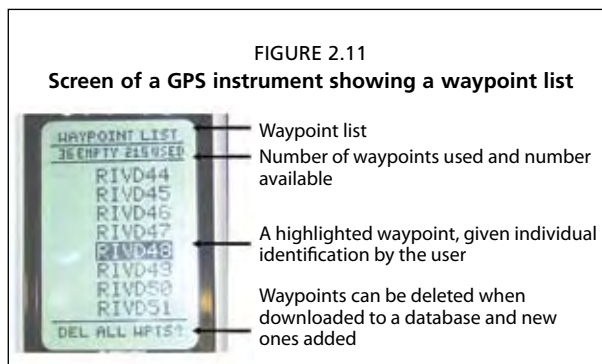
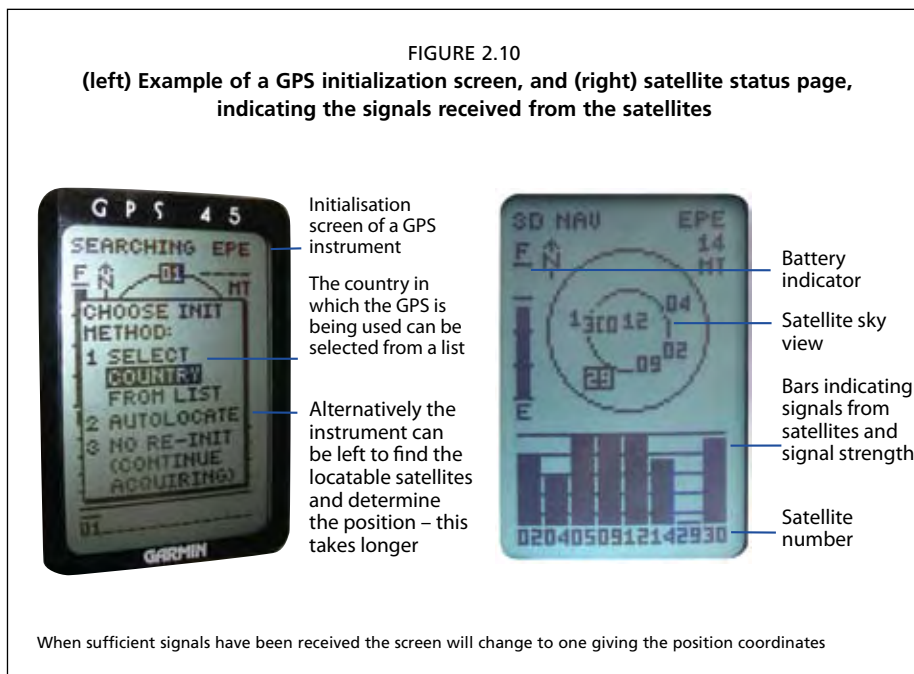

the precise coordinates. The GPS could still find the location without that information input but it would take longer. The instrument will then automatically start searching for satellites, and, depending on the model, will show what satellites it has located on the screen (**Figure 2.10, right**). When it has acquired sufficient satellites and determined the position, the screen will automatically change to one showing the coordinates, speed (velocity) if the GPS is moving, direction that it is moving in, the time and the date.

The units in which the coordinates are shown will depend upon the units that have been set on the machine — either the default units from the manufacturer or the units selected by the operator. GPS instruments have evolved rapidly as has the accompanying software for downloading the stored data to available GIS software and now, rather than writing down each individual GPS position at the time, which could be a potential source of error, the coordinates can be stored by the instrument as what are called waypoints (**Figure 2.11**). GIS software such as ArcView® / ArcGIS® and IDRISI has the ability to use a

list of waypoints as input and to create a GIS layer of points from them. So the waypoints can either be downloaded onto a computer using the appropriate cable and software available from the manufacturers, or hand typed into a table for import into a GIS. Software can also be obtained from the internet for downloading data from GPS instruments. There is a limit to the number of waypoints that can be stored on a GPS instrument, depending upon the model. When the limit is reached the waypoints have to be downloaded and deleted from the instrument. The GPS instrument's users manual will show how to download waypoints using a simple, on-screen menu. Each waypoint can be given a short identification code number (for example, the trap number or ID).

When entering, or loading a table of GPS positions manually the following points should be noted: X = longitude; Y = latitude; enter X and then Y. Coordinates should be written as decimal degrees (the instrument must be configured to display as decimal degrees) or UTM, but not as degrees, minutes, seconds (**Figure 2.12**). West of Greenwich, England, longitude values are negative, and a minus sign must be entered before each value. South of the equator latitude values are negative, and again a minus must be recorded.

Note: Collecting X,Y locations manually and entering them into a table for import into GIS should only be used when automatic downloading of files from the GPS to the computer fails. Handwritten lists always introduce errors, which are very difficult to locate afterwards.

2.4.2.3. Coordinates Systems for Georeferencing Data

Background — A coordinate system gives us a way to precisely describe a feature's geographic location, in other words, a frame of reference. Each coordinate system is composed of a datum that must be based on a certain ellipsoid, and a projection. The ellipsoid gives us the shape of the earth. The datum determines where the centre of that shape is, and local variations around the earth. And finally the projection converts from lat/log degrees around the ellipsoid to a flat plane for printing paper maps. There are several hundred coordinate systems in use around the world. Each country chooses a coordinate system that is best suited to the local conditions. We usually speak of two groups of coordinate systems: geographic and projected.

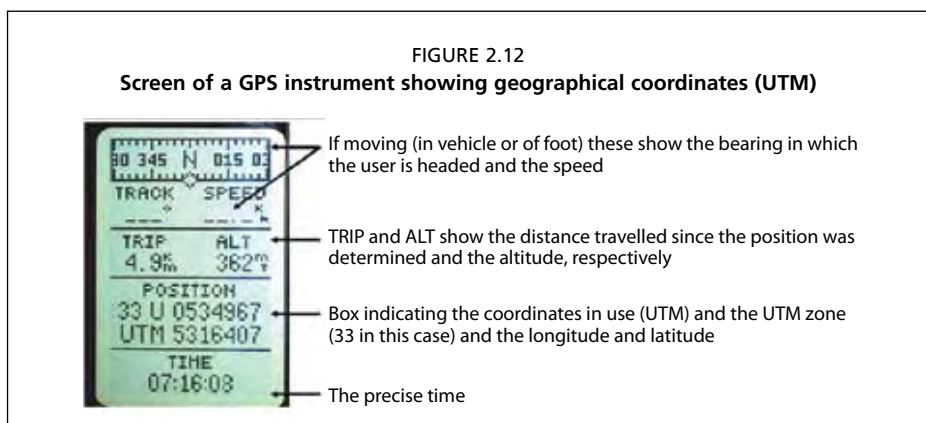
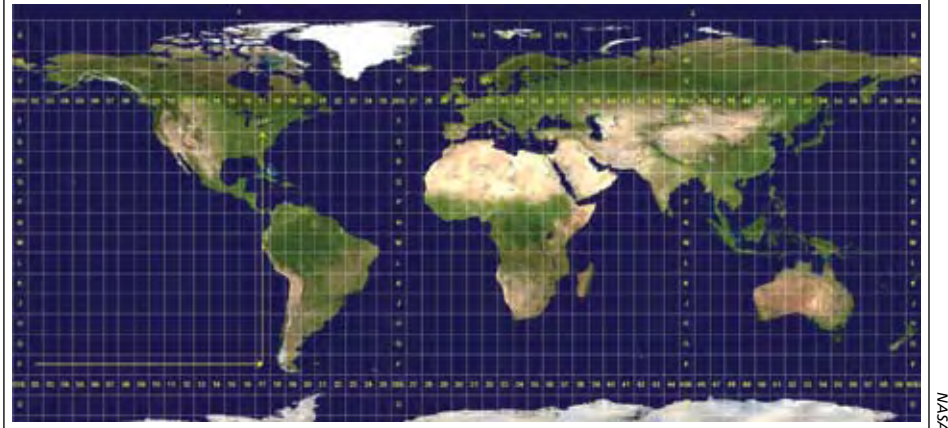

FIGURE 2.13
Satellite image of the world showing the UTM zones



The geographic coordinate systems have no projection. They are represented by a datum and ellipsoid only. Coordinates are in degrees latitude and longitude. GPS instruments always use a default geographic coordinate system known as WGS84.

Projected coordinate systems employ one of several dozen projection methods. Every projection causes distortion to some measure. Some projections maintain an accurate size of areas, but the features lose their shape. Others keep correct directions between features, but the measurement of areas gets distorted.

Country coordinate systems — Government survey offices will choose a coordinate system that gives the most accurate representation of reality on flat paper maps for that country. The choices depend on the shape of the country and local variations to the ellipsoid representation of the earth's surface. For example, countries with a longer N-S extent, that are less than 500 kilometres wide often choose a variation of the Transverse Mercator projection, which maintains accuracy in a north-south direction, but begins to lose accuracy when moving too far east or west.

UTM — UTM is a well-known set of coordinate systems, which uses the WGS84 datum and the Transverse Mercator projection (**Figure 2.13**). UTM is comprised of 120 different coordinate systems. The earth is divided into 60 longitudinal zones, each zone being 6 degrees wide. Each of those 60 "strips" is split at the equator creating a north zone and a south zone, thus 120 separate coordinate systems. Each zone has a central meridian, the line that goes down the centre of the strip. UTM units are meters. For northern UTM zones the origin (0,0 coordinate) is at the equator, and 500 kilometres west of the central meridian. For southern zones, the origin is 10 000 kilometres south of the equator, and also 500 kilometres west.

BOX 2.4**How GPS work**

GPS instruments calculate their position on the earth by measuring their distance from a group of satellites in space that act as precise reference points. This depends on a process of triangulation in which a GPS receiver measures distance using the travel time of radio signals. The distance from satellites is calculated using the formula:

$$\text{Velocity} \times \text{Time} = \text{Distance}$$

Knowing our exact distance from a satellite in space, we know we are somewhere on the surface of an imaginary sphere with radius equal to the distance to the satellite radius. If we know our exact distance from two satellites, we know that we are located somewhere on the line where the two spheres intersect. A third measurement will give the only two possible points, one of which is usually impossible and is eliminated by the GPS receiver.

GPS instruments measure a radio signal so the velocity is equal to the speed of light (299 792 458 metres per second). The measurement of travel time obviously requires very precise timing made available from atomic clocks on board the satellites. The precise location of the satellites in space is also required and this is achieved by placing them in carefully monitored high orbits. Mathematical procedures are used to correct for delays in the time taken for the signals to pass through the atmosphere in order to increase precision.

Each GPS satellite transmits an accurate position and time signal. The

type of signal transmitted is a pseudo random code (PRC). The PRC is a digital code, consisting of a sequence of "on" and "off" pulses. The complicated nature of the signal is similar to that of random electrical noise, hence the name pseudo random. Each satellite has its own unique, complex PRC and signals from other satellites are unlikely to have exactly the same shape and thus interfere with the receivers operation. Consequently, all satellites can use the same frequency. The GPS instrument measures the time delay for the signal to reach the receiver, which is a direct measure of the apparent range (distance) to the satellite. Measurements collected simultaneously from four satellites are processed to determine the three dimensions of position, velocity and time. Mathematically four satellite ranges are needed to determine the user's exact position, but three are sufficient as some positions (not on earth) are not possible. GPS receivers differ in the number of satellites they can receive from simultaneously, their precision, the nature of the display, and computer-downloading capabilities. All major manufacturers of GPS equipment maintain websites that include basic information about how the GPS works. Some GPS units display additional data, such as distance and bearing to selected waypoints or digital charts.

GPS provides two levels of service — a standard positioning service (SPS) for general public use and an encoded precise positioning service (PPS) primarily intended for use by the United States Department of Defence. There are some potential sources of error preventing absolute accuracy with standard GPS, however, these errors can largely be

corrected for using differential GPS providing accuracy within less than one metre. These are more expensive to use and only necessary if a high degree of accuracy is required. SPS signal accuracy was intentionally degraded to protect United States national security interests. This process, called selective availability, controlled the availability of the system's full capabilities but was turned off in May 2000 resulting in GPS becoming more accurate for civilian users.

2.4.2.4. Types of GPS Instruments

The wide variety of GPS instruments is sometimes grouped into two categories: navigation or recreational units, and data logger units. The navigation units will have a screen, often showing a simple map background. The user can set his destination, and the GPS will guide him/her to that spot. In addition the GPS can record waypoints as spot locations along the way. These instruments are relatively inexpensive, and often limited in memory and battery power. They are designed, as the name suggests for navigating, and not for data collection.

At the other end of the spectrum are data logger GPS units. These are typically much more expensive, and they are actually a mini computer sometimes running the Windows CE (Personal Digital Assistance) operating system. They are primarily designed for collecting data along with the GPS location. The internal battery will last all day, and is rechargeable. An auxiliary battery can be attached if necessary. They come equipped with very large memory allowing for collection of thousands of features as well as their accompanying attributes. Usually the GPS case will be sealed insuring that dust and moisture will not

FIGURE 2.14
Example of a data dictionary screen

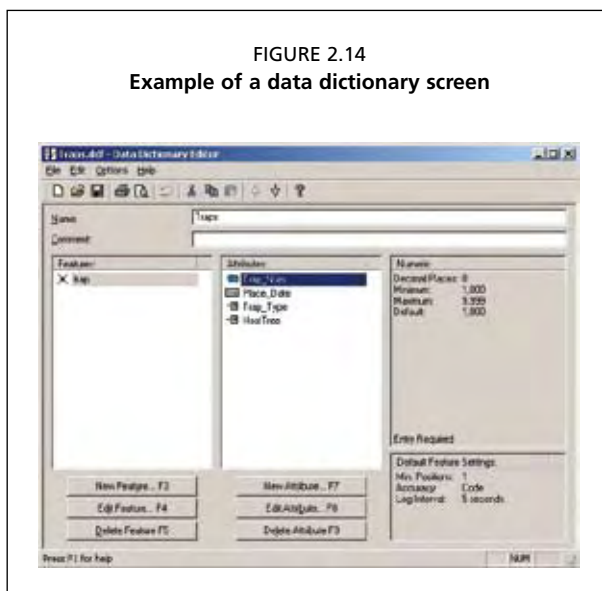

BOX 2.5

GPS Elements

GPS has three parts, termed segments, i.e. the space segment, the user segment, and the control segment (**Figure 2.15**). The functions of these are as follows:

Space segment

The space segment, consists of a series of 24 or more satellites (variable because new satellites are launched and older ones taken out of the system periodically, 21 active at any time) in six circular orbits 20 200 km above the earth at an inclination angle of 55 degrees with a 12 hour period. The GPS satellites (**Figure 2.16**), each taking 12 hours to orbit the earth, are equipped with accurate atomic clocks that keep time to within three nanoseconds, i.e. 0.000000003 seconds, or three billionths of a second and continuously transmit data signals including position and a precise time message on two different frequencies. This precision timing is important because the receiver must determine exactly how long it takes for signals to travel from each GPS satellite. The satellites, deployed and maintained by the United States Department of Defence, are spaced in orbit so that at any time signals can be received from a minimum of six of them anywhere in the world, i.e. the minimum signals required to get the best position information. The receiver uses this information to calculate its position.

Control segment

The control segment consists of a master control station (at Schriever Air Force Base, Colorado, USA), with five unmanned

monitor stations and three ground antennas located throughout the world, and four large ground antenna stations that broadcast signals to the satellites. The monitor stations track all GPS satellites in view and collect ranging information from the satellite broadcasts. The monitor stations send the information they collect from each of the satellites back to the master control station, which computes extremely precise satellite orbits. The information is then formatted into updated navigation messages for each satellite. The updated information is

FIGURE 2.15
Diagram displaying the three major segments of a GPS, i.e. the space segment, the user segment, and the control segment

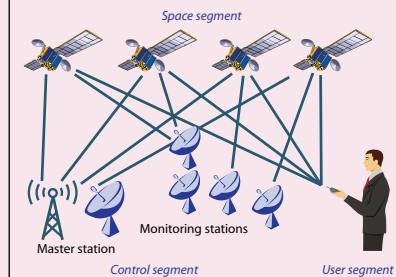

FIGURE 2.16
Photo of a GPS satellite



transmitted to each satellite through the ground antennas, using an S-band signal. The ground antennas also transmit and receive satellite control and monitoring signals.

User segment

The user segment consists of the hand-held, or vehicle-mounted signal receiver units, that allow land, sea, or airborne operators to receive, decode and process

the GPS satellite broadcasts to compute their precise latitude, longitude, altitude, velocity and time. A wide range of receiver models are now available, some, pre-loaded with road or other maps and additional features. The typical hand-held receiver is about the size of a cellular telephone, and the newer models are even smaller. Price has also significantly decreased since the first GPS instruments were commercially available.

interfere with operation. And the most important feature available with these instruments is their smooth interface with GIS.

Using a data dictionary — The data logger GPS allows one to define in advance which attributes we want to collect together with the location data. A data dictionary file is created in the computer that defines each attribute (or column). The data type, default values, menu items, etc., is determined (**Figure 2.14**) and the data dictionary file is uploaded to the GPS data logger. When collecting features in the field, attribute data is entered as the GPS is collecting the location data. Later, the GPS data file can be downloaded to the computer, the conversion programme can be run, and within the GIS our locations together with the attribute data entered in the field are immediately available. This method saves a tremendous amount of time, and avoids errors in data entry.

GPS data imported to GIS software — Any reasonable GPS instrument comes supplied with a software application to download GPS data to a personal computer. In addition, most sophisticated instruments include software modules to convert the downloaded GPS files to GIS format, and at the same time to re-project the data to the local coordinate system. The Trimble® line of GPS instruments use the Pathfinder Office software package for just that purpose. The user must know which coordinate system is used in his country in order to setup the conversion programme correctly. Once configured, the programme will automatically convert GPS captured locations to GIS layers that will correctly overlay other data obtained from outside sources. Pathfinder Office can convert the GPS data to shapefiles for use in any GIS application.

Note that the shapefile format contains the attribute data in a *.dbf file (part of the shapefile standard). This table of data can also be imported into the Tsetse Intervention Reporting and Recording System (TIRRS) (see 2.4.4) database application or other applications that recognize the *.dbf format.

Furthermore, a data logger GPS allows us to collect GIS features: lines, areas, as well as points. This concept is important to understand. The data logger GPS is not simply for

collecting waypoints. We can map out fields, roads, vegetation or land use areas. And in each case we enter attributes for each feature as the GPS collects the locations. Once the GPS data is transferred to the computer we will have all entered data immediately available in our GIS programme.

Mapping out roads and tracks is a simple and very useful GPS activity. A data logger GPS will automatically record locations all along the road as we travel, and when the GPS file is exported to GIS in the computer, all the locations are joined together resulting in a GIS line layer. Before starting to capture the road we can configure the interval of time (or distance) the GPS uses to log locations. Thus, if we are travelling at a high speed along a well-paved road, we would choose a small interval – about three seconds – for the logging interval. If, on the other hand, we wish to capture a track through rough terrain, where our speed changes all the time, we can choose to log by distance rather than by time. Logging a location every 50 meters insures that we will capture all turns and twists in the track. If we come to an obstacle while recording the track, and we must detour, the GPS allows us to pause collection of locations. After circling around the obstacle, and getting back onto the track, we can resume logging, and the final GIS layer will still be one connected line. In addition, we can define in the data dictionary the road condition as an attribute. As we advance along the road, we can section the road off, and choose the current condition to be recorded in the GPS. Again, the resulting GIS layer will contain the road condition as an attribute for each road section.

2.4.3. Defining the Limits of the Survey Area

The preparatory phase for any project involving large- or small-scale tsetse surveys in the context of AW-IPM will include the collation of available data on tsetse distribution from previous surveys, reports of trypanosomosis infections of livestock (or humans), etc., including any available distribution maps. The most widely available continental tsetse distribution maps have been, until recently, those published by Ford and Katondo (1977) but these were of limited precision as well as being rather outdated. In some areas significant changes in distribution have taken place due to re-occupation of formerly inhabited areas by tsetse recovering from the 1890s rinderpest epidemic or for other reasons. Recently, those maps have been updated and published (Maudlin et al. 2004). Much valuable information may be obtained from published scientific or other literature such as reports and various archived documents.

Determining the limits of distribution is one of the most important objectives of a survey, and more difficult than showing the presence of tsetse within an area. Tsetse density will be low, and presence may be seasonal and, as often stated, catching a tsetse shows their presence but not catching them does not prove their absence. The limits of the survey area will therefore normally extend beyond the expected limits of distribution. It may sometimes be necessary to adjust the limits of the survey area if initial survey results suggest that they were not well defined. Based on the available information on tsetse distribution, plus predictive maps, preliminary survey data and satellite imagery, a better estimation of the limits of the area to be surveyed can be made. The limits of the area may be determined partly by the presence of natural boundaries to tsetse infestation such as lakes, or areas of high altitude, that are unsuitable tsetse habitat. Other limits may be less clear and might

have to be determined using data obtained from preliminary surveys that will have to be (or will have already been) conducted in the area. If an area is selected because of endemic trypanosomosis, it is probable that previous disease prevalence data are available. The available predictive maps of tsetse species distribution in Africa, based on climatic and other data have already been referred to. These maps, freely available over the internet or on CD-ROM can be used, in conjunction with satellite images, as a basis for determining the limits of an area, bearing in mind the necessity to survey some adjacent areas in which tsetse are

FIGURE 2.17
Predicted distribution of *Glossina fuscipes fuscipes* in northern Lake Victoria (Uganda and Kenya)

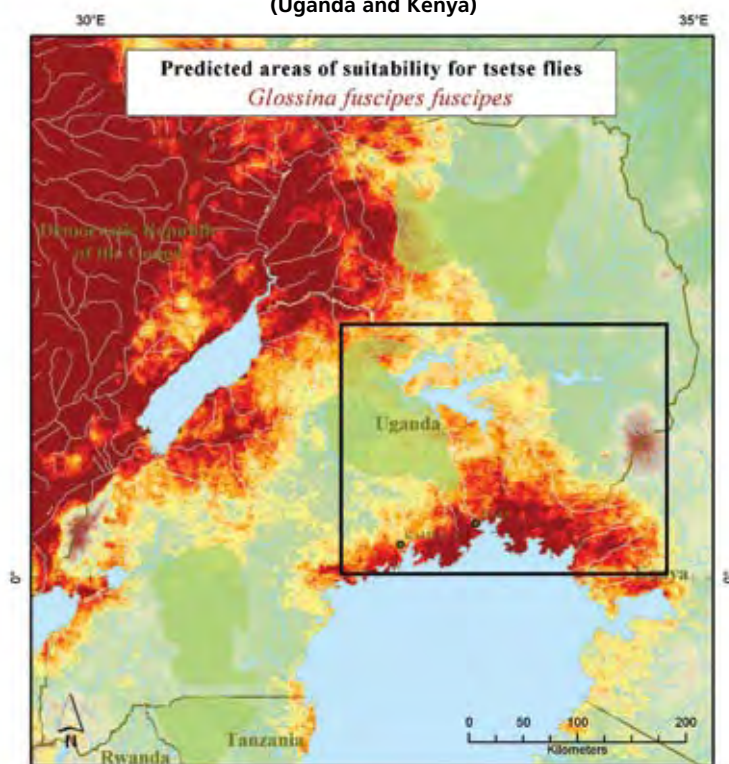

 
 This map shows the predicted areas of suitability for tsetse flies. Predicted areas are based upon similarities of environmental conditions to those at sample sites within the distribution of tsetse. The map was produced by FAO/IAEA in 2001. The prediction was created at 1 kilometre resolution and it is based on the best available information at the time of production. On the left, the continental prediction based on data at 5 kilometres resolution.

- Glossina fuscipes fuscipes***
 Prediction of suitability
- 10% - 25%
 - 25% - 50%
 - 50% - 75%
 - 75% - 90%
 - 90% - 95%
 - > 95%
 - Cleared of tsetse since 1957
 - Rivers
 - Countries borders

The rectangle is the area covered by the satellite image in Figure 2.18

potentially absent in order to verify this. The maps can be viewed and other information is available from the following link: <http://ergodd.zoo.ox.ac.uk>.

Figures 2.17 to 2.24 illustrate the hypothetical sequence of survey planning from the early stage of identifying a circumscribed tsetse population, potentially suitable for AW-IPM, from a predictive map showing the probability of presence, through to a survey map showing distribution. **Figure 2.17** shows the predicted distribution of *G. fuscipes fuscipes* around the northern shores of Lake Victoria in East Africa. Having identified an area of interest such as this, a satellite image is acquired of the part of that area (**Figure 2.18**) in which AW-IPM is contemplated, and a survey is to be planned. That satellite image can be used to prepare a vegetation map, or, if such maps already exist (**Figure 2.19**), can be used in conjunction with them, to identify the vegetation types that are associated with the predicted presence of tsetse. That process is likely to require some ground truthing (physically visiting an area identified on the satellite image and predictive map) to be able to characterize the type of vegetation (e.g. savannah woodland, thicket or lacustrine forest) associated with the presence of tsetse. The process of identifying the types of habitat in which tsetse are likely to be present will also make use of the entomologists knowledge of the ecology of the tsetse species and its known habitats and of areas that are likely to be unsuitable for the flies. At the end of this process the entomologist will be in a position to use standard 1:50 000 scale topographical survey type maps to outline the limits of the survey area (**Figure 2.20**) and to start to construct a grid overlay based on the grids found on the standard hard copy maps, or, if they don't exist, to construct an electronic grid that can be overlaid on satellite images of digital maps or printed out on transparent paper for use with hardcopy maps. **Figure 2.21** shows a satellite image corresponding to the same smaller area of Kibanga that is shown on the previous maps to illustrate the way in which it is possible to zoom in on the higher resolution satellite images in order to obtain a

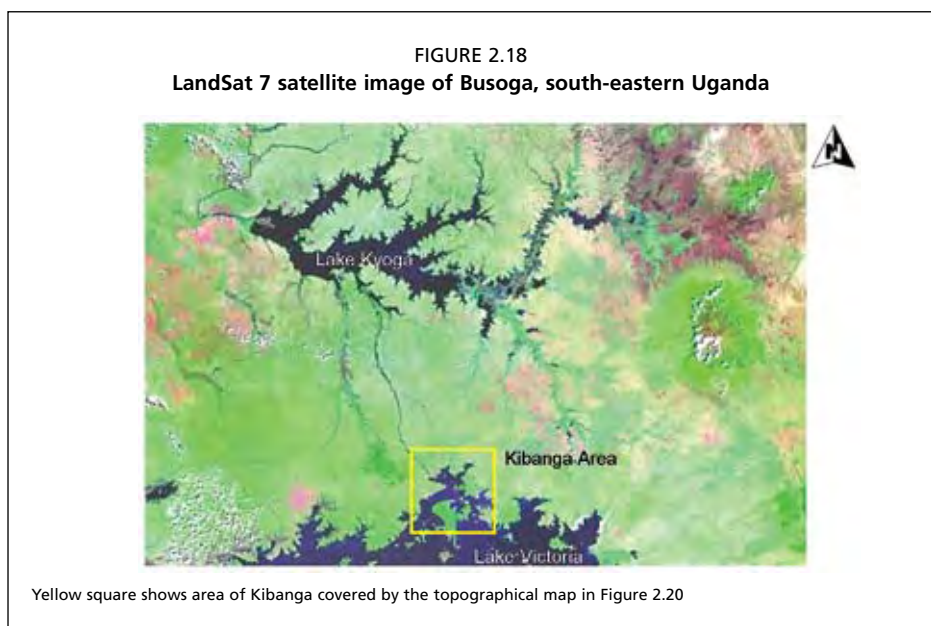
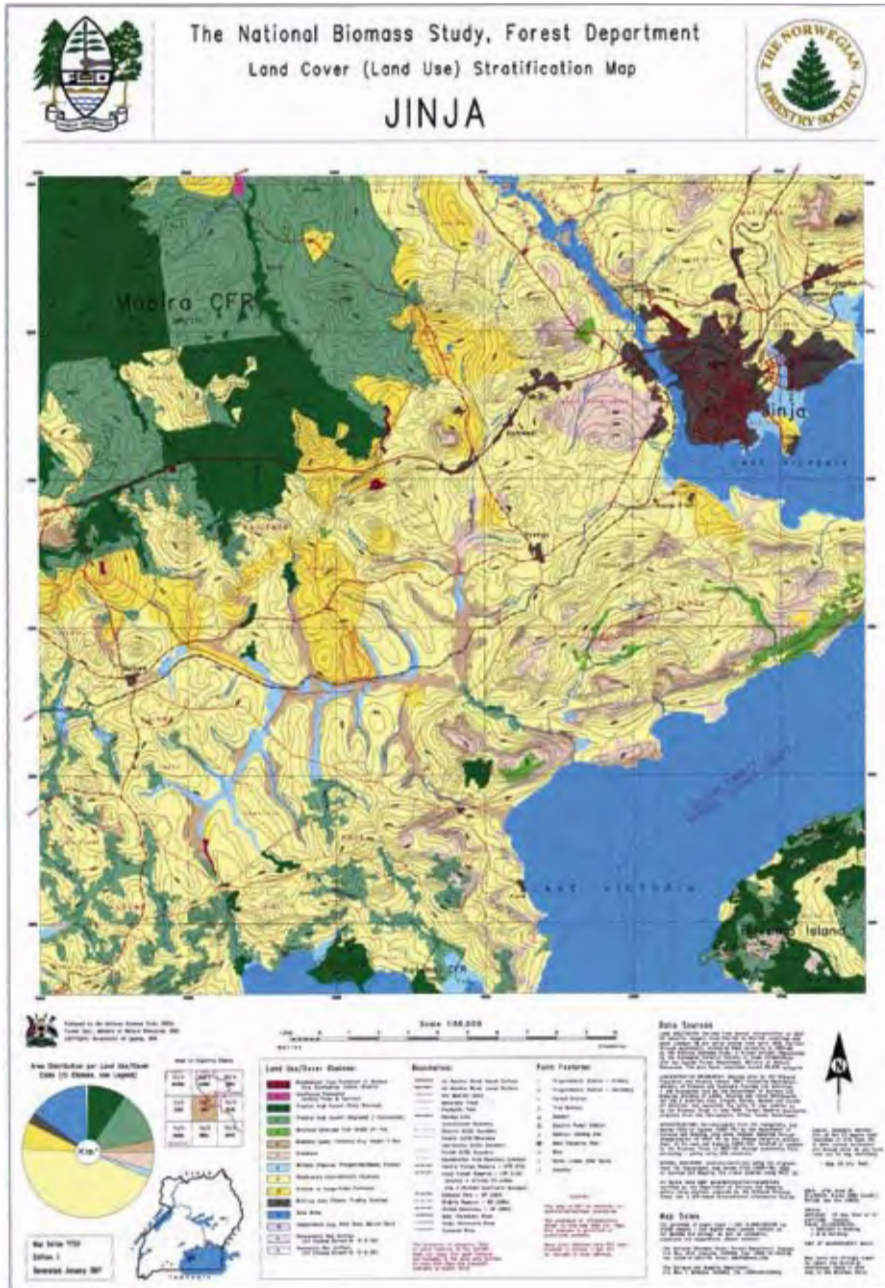

FIGURE 2.19
Land cover map of Jinja, south-eastern Uganda



NATIONAL BIOMASS STUDY OF THE FOREST DEPARTMENT OF THE MINISTRY OF NATURAL RESOURCES, GOVERNMENT OF UGANDA

FIGURE 2.20
(upper) National survey map of Kibanga, Uganda, showing (circle) details of map projection, and (lower) a 10 × 10 km UTM grid square enlarged (area shown in Figure 2.21 as a satellite image)



Grid: UTM Zone 36
Ellipsoid: Clarke 1880 (modif.)
Datum: New Arc (1980)
Meridian: 33 Deg. East of Gr.
Latitude: Equator
False Coordinates:
500,000 m Easting
0 m Northing
Unit of Measurement: Metre

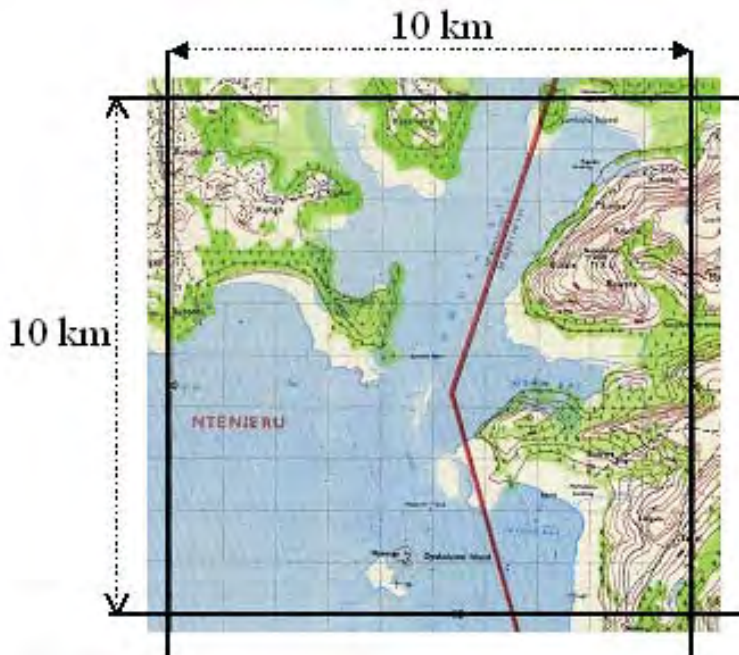

FIGURE 2.21
LandSat 7 satellite image of Kibanga, Uganda



NASA

greater detail. The very high, submetre resolution images of the type available from Quickbird (www.digitalglobe.com/about/quickbird.html) or Ikonos (<http://www.landinfo.com>) will even show roads and tracks that can be used for planning access routes, however, at present their cost is likely to be too great and the 30-metre resolution LandSat 7 images are adequate for survey purposes.

The details of the type of grid structure to be used, and the organization of the survey and its teams based on the grid structure are given in 2.4.3.1. It is becoming increasingly common to find that accurate and recent digital or hardcopy vegetation or land use maps are already available for an area such as that shown in **Figure 2.22** which shows land use

FIGURE 2.22
Vegetation map of part of The Gambia

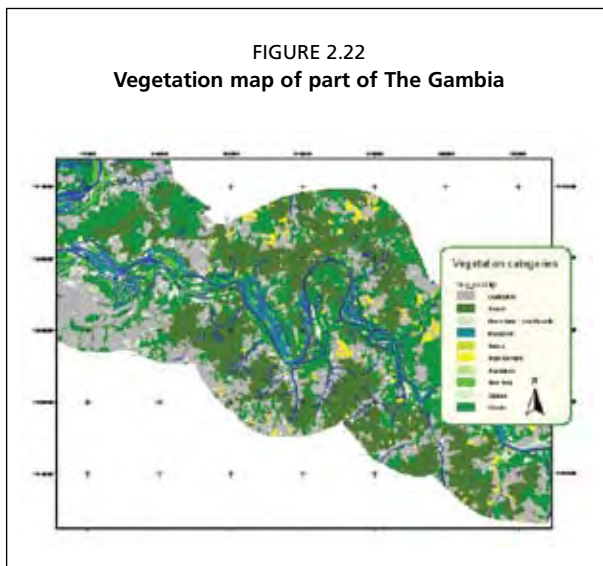

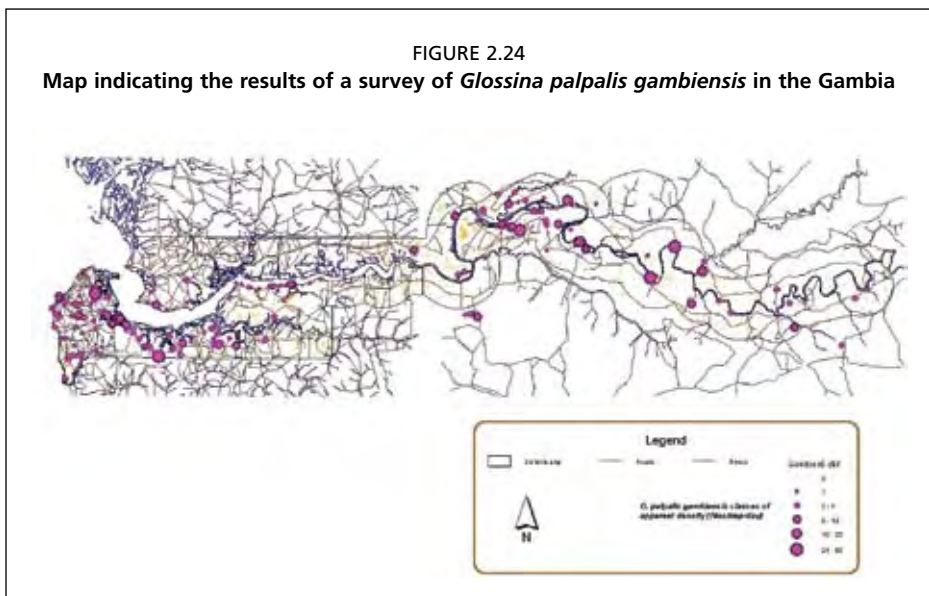
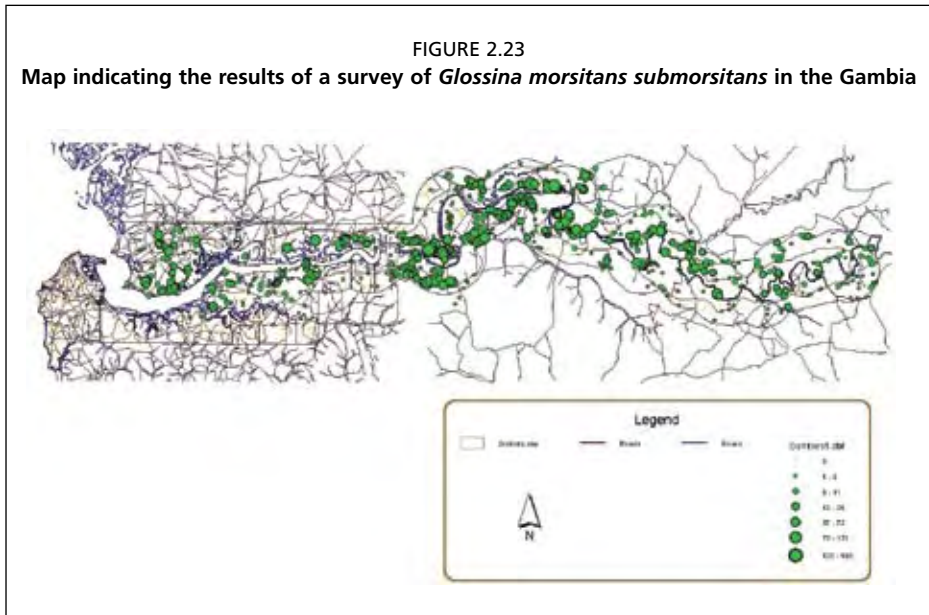

in a section of The Gambia from satellite interpretation and mapping carried out by the Japan International Cooperation Agency (JICA) and the Gambian Department of Surveys in 2002. Similar land cover maps are available for many parts of Africa, sometimes freely over the internet (i.e. FAO AfriCover — <http://www.africover.org>) and may be readily customized to map tsetse habitat (Cecchi et al. in press). The International Livestock Research Institute website (<http://www.ilri.cgiar.org/gis/>) provides GIS databases for Ethiopia, Kenya, Uganda and such sites are continually being added to.

In the vegetation map of part of The Gambia (**Figure 2.22**), produced in GIS using a recently produced land use coverage data layer, the main potential classifications of habitat suitable for tsetse are: forest, woods and palms. Cultivated land, rice fields, swamp and plain ground are less suitable habitats. Note the location of rice fields in proximity to the River Gambia and the relationship between cultivated land and alluvial soils along tributaries, particularly on the south bank of the river.

The final result of the survey can be depicted on maps using GIS software in a variety of ways, one of which, using size graduated circles to represent different apparent density classes is shown in **Figure 2.23** and **Figure 2.24** for the two species of tsetse present in The Gambia, *Glossina morsitans submorsitans* and *Glossina palpalis gambiensis*, respectively (data from Rawlings et al. 1993, converted to a GIS format and redrawn by Leak et al. 2004).

Standard ordnance survey type maps, especially the older ones, are often based on aerial photographs. They generally show contours, which are useful in some regions for defining limits, but show a limited amount of detail on land use/vegetation types, and that information may be out of date. That is why they are used in conjunction with satellite images that can provide contemporary information on vegetation and land use. The type of map shown in **Figure 2.22** is produced from recent interpretation of satellite images carried out together with "ground truthing" (verifying on the ground that the interpretation made from an image is correct).

2.4.3.1. Setting Up a Grid

A grid system is used for planning and organizing a survey because it permits a logical sequence of activities to be followed, efficient organization of teams and a means of checking on progress. Although grid structures have been used to provide a framework for visualizing survey results, especially before the wide use of GIS software, this is not the best means of displaying such data. Rather than averaging data and forcing it into a grid structure for visualization, GIS tools for interpolating data from traps can be used to give a better visualization of results over a large area. In order to create a grid structure for survey management, a grid of the required size is superimposed over a map of the area. This will either make use of existing grids found on standard ordnance survey type maps, simply constructing one with a ruler, or alternatively using a computer to make a grid on an electronic copy of a map. The grid square size will be decided upon according to the size of the survey area, as described below, and the grid squares covering the survey area will be divided up into blocks subsequently assigned to each survey team. The survey teams will then work through each of their assigned grid squares in their block sequentially and methodically.

In the past, surveys were often carried out using administrative boundaries (provinces, districts, divisions, etc.) as units defining survey limits. That procedure may have been adequate at the time and for the purposes for which it was intended, but is inappropriate for surveys in the context of AW-IPM, in which the entire population has to be surveyed, as that population will not be confined to administrative (even national) boundaries. In the past it was easy to organize surveys based on administrative boundaries. In contrast, mobilizing staff allocated to local administrations or alternatively using a national survey

team carrying out surveys crossing administrative boundaries may now meet some difficulties, especially related to decentralization of local governments and budgets, requiring all the administrative units involved (including governments in the case of regional projects) to agree to coordinated activities, it is, nevertheless, the required approach.

The grid structure provides a framework that can be used for planning the distribution of trap deployment. The type of grid used will depend upon the size of the area to be surveyed. In relatively small areas it might be appropriate to use 1-km² grids and to conduct quite an intensive survey that will give a better “resolution” of the survey results. However, where area-wide tsetse control/eradication is being considered the area to be surveyed is quite likely to be large and small grids of 1 km² would be impractical because it would not be feasible to deploy traps in every square, given likely difficulties of access to some areas. In such situations a 10 × 10 km grid square (i.e. 100 km²) would be more appropriate, as described below in the example from Ethiopia of the baseline survey of the Southern Rift Valley Tsetse Eradication Project (see 3.5.2.). Similarly, in Togo, a country-wide survey (not for the purpose of AW-IPM) made use of a grid base of 311 identical cells, with each cell side measuring 0.125° latitude/longitude (see 3.5.1.). In larger-scale grids, more care has to be taken in selecting sites for deployment of traps that are representative of the vegetation types in the grid square as it will not be possible to deploy traps in all of them. Obviously, this provides a lower level of resolution and the interpolation of data to unsampled areas may have limited accuracy. The methodology used for organizing surveys on a grid structure is the same whichever size of grid is used. Having an appropriate size of grid will ease the logistical management of the survey.

2.4.3.1.1. Procedure for Preparing a Grid and Allocating Blocks to Survey Teams

Having defined the area for the survey using predictive (probability of presence) maps, satellite images and probably national survey maps, 1:50 000 scale and 1:200 000 scale maps covering the entire area, normally with a bit of overlap into surrounding areas should be obtained. A minimum of one set of maps per team will be required plus an additional set (or two) for the survey management office. It is advisable to trim or fold and fasten together at least one set of these maps so that the whole area can be displayed. The boundary of the survey area is outlined with a felt-tip pen, as well as the grid squares (either UTM grid squares or 1 × 1 km squares, whichever is chosen). An identification system for each grid square is created using for example letters for the grid squares going from left to right and numbers for the grid squares from top to bottom. Those grid references will remain fixed and will be recorded on the top of each survey data-recording sheet so that the data can be correctly assigned to the appropriate grid square. Grid squares are assigned to each survey team, taking into account the location of the survey teams base (not always the same as the project management office or for each team, depending on the size of the survey). The terrain and difficulty of access should also be taken into account when assigning grid squares to teams; it may not always be the case that each team will have exactly the same number of grid squares to cover (e.g. **Figure 3.20**). A sketch (or printed) maps is then provided showing the grids assigned to each survey team, together with the 1:50 000-scale set of maps.

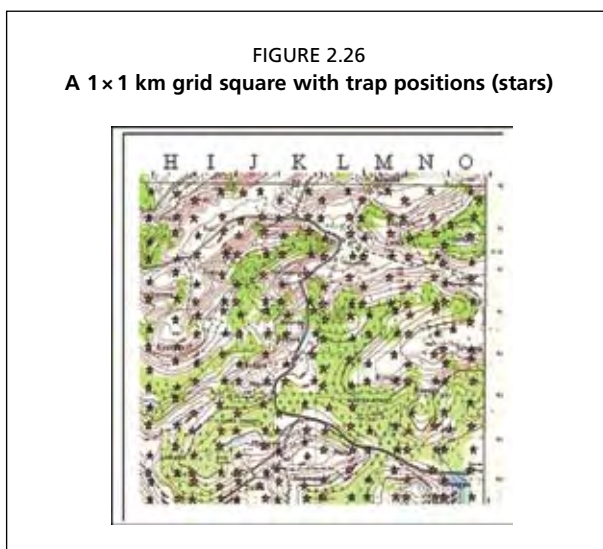
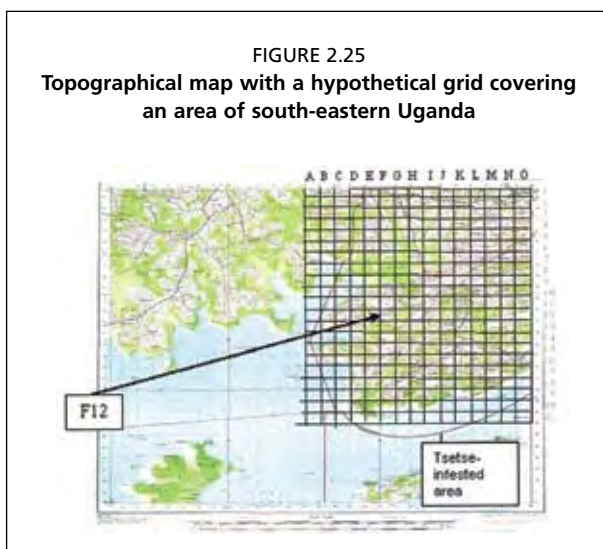

Small-scale surveys based on 1 km × 1 km grid squares — Following selection of the area, and identification of the limits of the survey area, based on approximately known boundaries of the infestation and natural boundaries such as highland or lakes, a grid is constructed over the base map. Standard 1:50 000 ordnance survey type maps already have a 1-km² grid overlay in addition to the 10 × 10 km grid. This 1-km² grid can be highlighted on the map and each grid square given a unique identifier using an alphanumeric system as shown in **Figure 2.25**.

Figure 2.25 shows a hypothetical simplified (and therefore not completely realistic) example of how to set up a small-scale grid. The basic map is a 1:50 000-scale ordnance survey type topographical map of a kind that is almost universally available. The map has the 10 × 10 km UTM grid squares in bold outline, and 1 km × 1 km grid squares in fainter

outlining. Let us assume that the area within the brown line is an isolated infestation of a tsetse species bounded by the natural barrier of the lake, highlands to the north and east and intensive agriculture on the west. A 1 km by 1 km grid is constructed simply by highlighting the existing grid structure that overlays the area to be surveyed. Rows of letters along the top and numbers along the side can be used to give a unique identifier to each square. So that the square indicated by the arrow can be identified uniquely as F12.

Having developed a grid, the survey can be planned systematically. The area covered by the grid in this example is just 315 km², although some of those grid squares are entirely water so they would not be surveyed. That area could be covered by three survey teams each responsible for 105 grid squares and in this example the area could be easily divided up, with the first team taking columns A–O and rows 1–7; the second team takes columns A–O and rows 8–14; and the third team taking columns A–O and rows 15–21.

With three teams covering a relatively small area it would be quite feasible to deploy four traps in each grid square, selecting sites considered to be most suitable for catching tsetse, for three days of trapping with each trap being serviced (cages checked, emptied and replaced) daily. Deploying 20 traps a day, each team would finish surveying its area in 23 days. The approximate areas for deployment of traps could be pre-selected based on access, vegetation type and proximity to rivers and streams, as indicated by the stars in each 1 × 1 km grid square of **Figure 2.26** and the precise positions would be recorded with GPS instruments after deployment.

In 3.5.4., an example is provided of a small-scale intensive survey conducted in the Ghibe (Omo) River Valley in Ethiopia, in which the total area to be surveyed (in two sites, i.e. Ghibe and Tolley/Gullele) was only about 450 km². In such a situation a quite detailed tsetse distribution map can be produced allowing correlations to be made with specific ecological and environmental parameters.

Large-scale surveys based on a 10 × 10 km grid square — The methodology for setting up a large-scale survey grid based on 10 × 10 km squares is exactly the same as described for the small-scale survey except that it uses the larger squares, covering a greater area of 100 km² per grid square. For a large area it becomes logistically not feasible to use the same density of traps as for a small area. The resolution of the data on tsetse distribution and abundance will therefore necessarily not be as good as is possible for a smaller area. For that reason, care has to be taken to select representative areas within the 10 × 10 km grid and deploy traps in those representative areas in numbers proportional to the size and importance of them. Consequently, the deployment of traps will not be uniform as suggested by the hypothetical illustration in **Figure 2.27**. That figure shows diagrammatically, a single 10 × 10 km grid square within which there are 100 1-km² grid squares that can be grouped in fours. Even if the type of habitat within the 10 × 10 km grid were uniform, the deployment of traps also depends very much on accessibility and they will therefore be more clustered. Where there are grid squares that are unsuitable for tsetse or of very low suitability (water, high altitude, no suitable vegetation) those cells will be left empty. In a large area, the deployment of 20 or 25 traps per 10 × 10 km grid-square is the minimum to be aimed for (allowing an average of one trap for every 4 or 5 km², although not actually so uniformly distributed). There is no upper limit to the number of traps than can be deployed

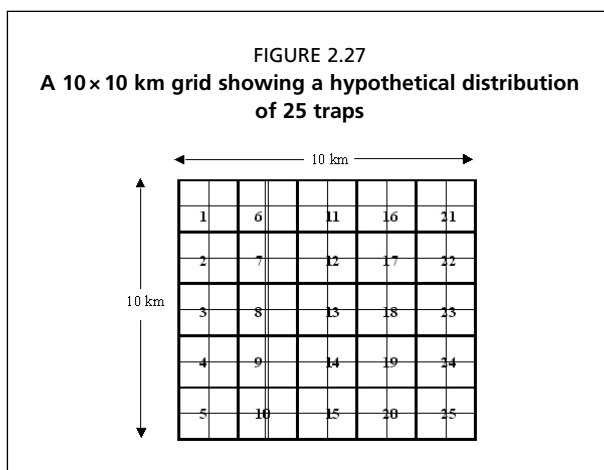

other than that which is practically feasible. The type of trap deployment described will give a lower resolution for tsetse distribution than is possible with the small-scale survey described above, and each trap has therefore to be carefully sited. Because of the lower resolution, and especially if, for example, aerial spraying is foreseen as the purpose of the survey, there will have to be a concentration of effort on the outer limits of the tsetse distribution rather than on the interior, as described in the following section.

2.4.3.1.2. Intensity and Duration of Sampling in Relation to Grid Structure

The intensity and duration of sampling in different areas of the survey area will depend partly upon the objectives of the survey (if aerial spraying of the population is to be undertaken surveying the interior of the block will be of little importance but defining the limits will) as well as on logistical feasibility. In theory, the duration of trapping, and number of traps could be determined by estimating those parameters in order to give a 95% probability of detecting any tsetse in the area, however, in addition to logistical difficulties there are many unknown parameters especially in relation to efficiency of traps for different tsetse species, in different locations and in different seasons. It has been shown that a minimum period of three days trapping is required to reduce variability of trap catches to acceptable levels and this is therefore taken as the minimum period for sampling (Williams et al. 1990). The most important part of a tsetse survey is to determine the limits of distribution and therefore sampling along the edges will be most intensive. The expected distribution limits may be known or roughly defined, enabling the outside boundary of the survey area to be approximated. Trapping in grid squares along this boundary will ideally be carried out using 35 traps in a 10 × 10 km grid square for a period of one week. If tsetse are caught within three days then trapping can stop, however, and proceed to the next grid square out. In that square the same number (35) of traps will be used for a period of 10 days to confirm, within practical limits, the absence of tsetse in that area. Similarly, if tsetse flies are caught then the next grid square is included until a grid square in which no tsetse flies are caught is reached. This approach to intensity and duration of sampling is illustrated in **Figure 2.28**.

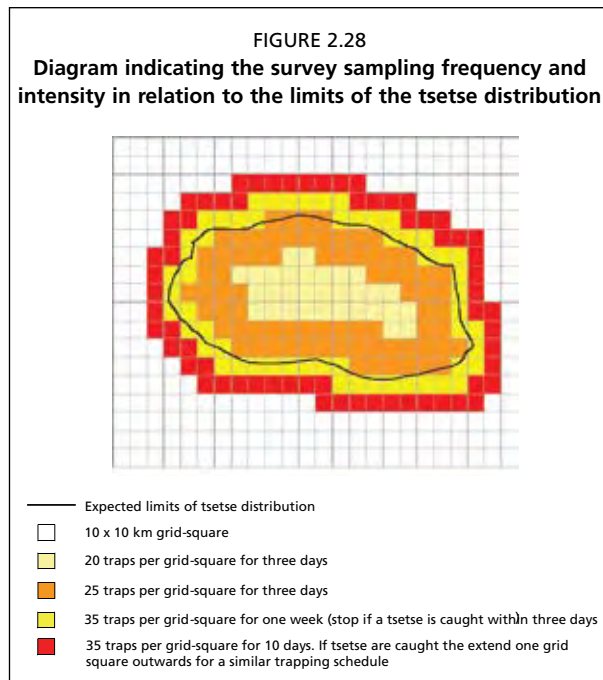

Off course, if the boundary of the distribution limits is well defined and unambiguous (a lake, ocean or high mountain range), then this procedure will be unnecessary.

Figure 2.29 provides a summary of the sequence of planning for an entomological baseline data survey.

2.4.3.1.3. Grid Systems for Riverine Tsetse Species in Humid Savannah

A grid system can be equally effective for planning a survey of *palpalis* group tsetse, although the differing habitat structure for these flies, compared to *fusca* or *morsitans* group tsetse needs to be considered. *Palpalis* group tsetse flies predominantly occupy a more linear habitat in humid savannah (**Figure 2.30**), with areas between gallery forests that may not be occupied by them as they are almost always found in close proximity to water. However, in forest areas, these gallery forests are often connected by forest and here, the flies may extend over a wider area. Furthermore, although *palpalis* group tsetse flies are known to be largely confined to the gallery forest habitat, especially in the dry season towards the northern limit of their distribution, they can disperse outwards into the bordering savannah, especially during the rains and this has to be taken into account when defining the area to be surveyed. Unfortunately, not enough is known about the extent of the seasonal dispersal away from the riverine habitat for different areas.

In the example given in **Figure 2.31**, although it might be strictly unnecessary to survey in the shaded $\frac{1}{4}$ grid squares, from a practical point of view it might be easier to simply survey the whole grid square. This would also give a better indication of the risk of re-invasion from neighbouring river systems. As Hendrickx et al. (2004) reported, a well known and typical feature of the climate and consequently of the vegetation type in West

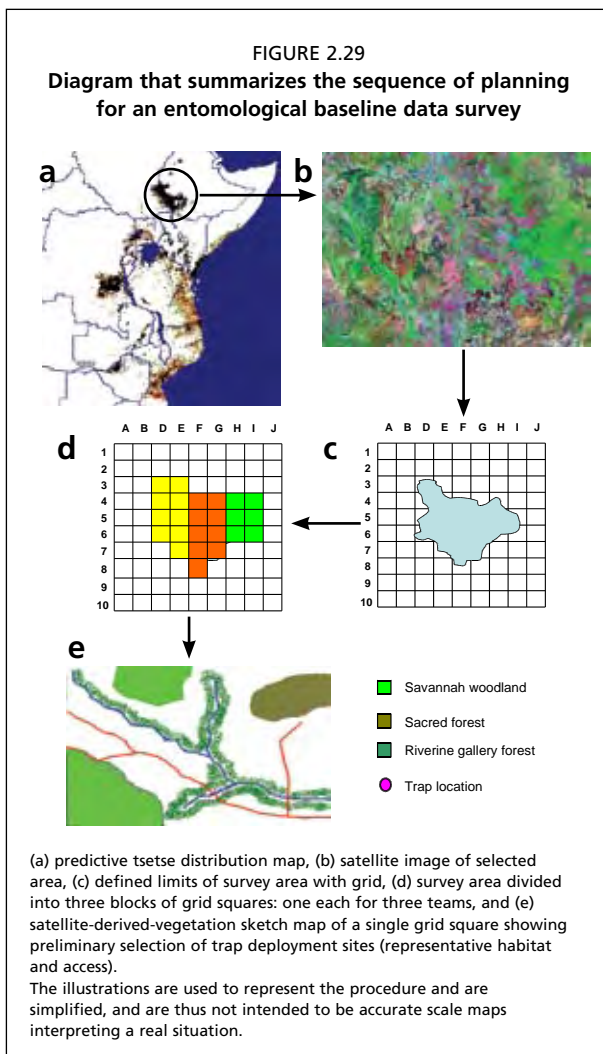

Africa is its band-like pattern. This can be shown using data on rainfall, vegetation index and the length of growing period. From north to south the climate changes from arid to moist. This strongly affects tsetse ecology and distribution, thus in the northern area of West Africa, close to the northern limits of their range, climatic conditions become less suitable for tsetse. It is particularly important to assess the seasonal changes in distribution and to survey so-called “forest islands” that might harbour tsetse, because of the suitable microclimate provided, in areas that are otherwise too hot and dry. *G. tachinoides* is particularly known to be able to survive further north in this region than other tsetse species by making use of the small, fragmented areas of habitat. In more southerly areas, where conditions are more favourable and tsetse flies are widespread, seasonal dispersal, rather than identification of isolated habitats, needs to be determined. This can be achieved by placing transects of traps outwards into adjacent grid squares from gallery forests into the bordering savannah grasslands or forests.

FIGURE 2.30
Band and enhancement combinations that highlight the gallery forests that are typical for parts of Central and West Africa



The image is used to illustrate the process of setting up a hypothetical survey grid for *palpalis* group tsetse flies

MASA

FIGURE 2.31
Grid system for riverine tsetse in humid savannah

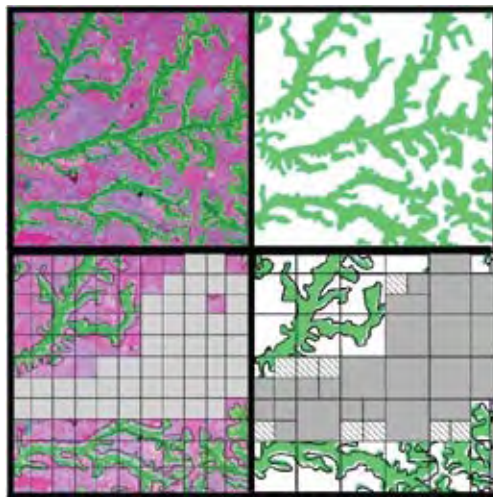

(upper, left) Landsat 7 satellite image showing Central African gallery forests that would be inhabited by riverine tsetse species of the *palpalis* subgenus, (upper, right) a simplified vegetation map showing only the gallery forests derived from that satellite image, (lower, left) a 10 × 10 km grid superimposed over the image/map, and (lower, right) the grid squares included (grey) and excluded (shaded) in the survey

2.4.3.2. Correcting Data for Seasonality of Survey Catches

Ideally, a survey should be repeated at different seasons of the year (as with the Ethiopian Southern Rift Valley Tsetse Eradication Project survey: see 3.5.2), in order to be able to assess seasonal changes in distribution and abundance and obtain more accurate data on tsetse distribution. However, for economic reasons, surveys may be carried out over an area with trapping once only in whatever season a particular area happens to come into the work plan. That will result in difficulties in comparing densities between one area and another if they have been surveyed at different seasons. Provided that some representative sites are identified for continual monthly trapping to provide the necessary data, there are appropriate methodologies that can later be used to correct the survey data for season. Note that the following correction methodology does not help to provide information on seasonal variations in distribution (presence or absence), only on seasonal abundance.

In order to correct for differences in time of year of the survey the catch data is standardized for month of collection by calculating the annual catch T , by adding the individual monthly catches ($t_1, t_2, t_3, \dots, t_{12}$) from the sites have been monitored monthly at all seasons (routine monitoring sites). The standardized survey catch is then calculated by dividing the actual catch (N) by the relevant proportion constituted by the monthly catch of the annual total catch $N/(tn/T)$, giving an annual expected catch at each site. This is then reduced to a monthly value by dividing by 12. This assumes that each 24-hour collection during the survey was representative of a whole month. That is of course, often likely to be an inaccurate assumption, especially in the rainy season, at which time there would be a good chance of a catch being disrupted and unrepresentative.

2.4.3.3. Examples of Grid-Based Planning for Large-Scale Tsetse Surveys

Some examples of tsetse fly surveys that have made use of grid-based systems for planning are given in 3.5. Although these examples used the grid structure to display the survey data, a better approach is to use GIS tools for interpolation of the data as described in a subsequent section. Only the Ethiopian example was a survey conducted specifically for the planning and execution of an AW-IPM programme, and covering what was believed to be the entire population of an isolated *G. pallidipes* infestation (Vreysen et al. 1999). Although the other examples were not in the context of AW-IPM control efforts, they do illustrate the methodology used for both large- and small-scale surveys conducted for different purposes. The surveys in The Gambia (Rawlings et al. 1993) and in Togo (Hendrickx et al. 1999) were similar in that they were country-wide surveys (both covering small, long and narrow Africa countries), and were conducted for epidemiological reasons rather than with immediate control/eradication projects in mind. In contrast, the survey in the Ghibe valley of Ethiopia was small-scale, and conducted primarily for research purposes in order to understand the success or failure of pour-on treatments of cattle for tsetse control and of the trypanosomiasis epidemiology in the area (Leak et al. 1995).

2.4.4. Setting Up a Database

2.4.4.1. Introduction

It is important to ensure from the initial planning stages that the method of data collection and recording and the way in which it is analysed is standardized. This can be achieved by having uniform, pre-printed data-recording sheets for field use and by making use of a standard database management system that has pre-prepared data-entry forms that are fully compatible with the paper recording sheets to be used by field teams. To standardize analyses, queries and report forms can also be prepared. The database and programmes for analysis and reporting should be designed and tested before the start of data collection to ensure that they provide the sort of data analysis that will be required. FAO/IAEA commissioned the development of a database package entitled "Tsetse Intervention Recording and Reporting System" (TIRRS) that can readily be linked to GIS software. Microsoft Access® provides users with one of the simplest and most flexible database management system solutions and TIRRS is a Microsoft Access®-based package that is customized to handle data from monitoring and baseline data tsetse surveys in the context of AW-IPM programmes.

To ensure standardization of data processing it will also be necessary to carry out a practical training course with the survey team members, with a dry run of data collection, entry and analysis to ensure that the system works. It is far preferable to put some effort into making sure that the required data is being collected, stored and analysed correctly at the beginning of a project rather than attempt to revise databases and data collection during the implementation phase.

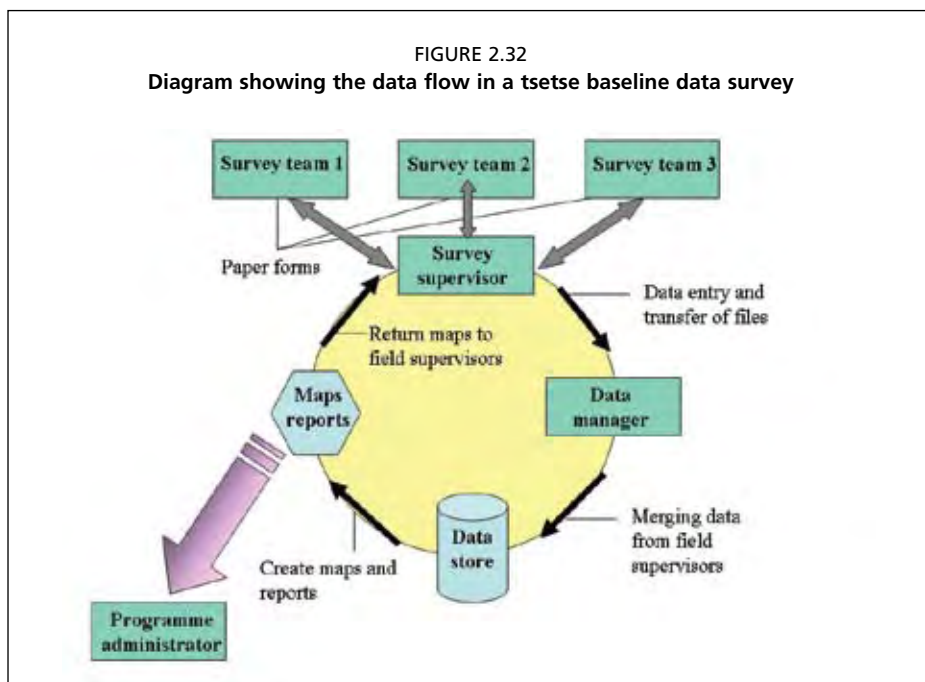

2.4.4.2. Data Flow

In a survey over a big area, a large quantity of data will be generated. In order for these data to be fully used in an interactive way that will allow the survey procedure to be “fine-tuned” as it progresses, those data will have to be rapidly entered into a database, analysed and results reported. This will require an efficient, two-way channel of communication between survey technicians, data entry persons, data managers, and the survey management team as outlined in **Figure 2.32**.

In a large survey area, or where there are some physical barriers to communications (lakes or rivers), it might be appropriate to have field teams based in different locations within their area of activities. In such circumstances, each team should be equipped with a computer for data entry. Data will then be transmitted from each field team on a weekly basis to the survey supervisor. The survey supervisor will pass data to the data manager, who will pass it to the data entry personnel for collation in an overall database from which weekly reports will be generated. Any problems with data noticed during data entry (incorrect or missing data) will be passed back through the data manager and survey supervisor to the field teams for correction/verification the following week. Similarly, the weekly-generated report will be passed back to the survey supervisor for evaluation so that, if necessary, alterations can be made to the survey procedure or work plan, in response to observations arising from the report (e.g. areas that might need repeated or more intensive survey).

2.4.4.3. Database Management Systems

A database is an organized collection of data. Database management systems such as Microsoft Access®, Oracle, SQL Server or MYSQL provide us with the software tools we need to organize data in a flexible manner. It includes facilities to add, modify or delete data from the database, ask questions (or queries) about the data stored in the database and produce reports summarizing selected contents.

Microsoft Access® provides users with one of the simplest and flexible database management system solutions. TIRRS is a Microsoft Access®-based database management system that is customized to handle data from baseline tsetse surveys in the context of AW-IPM programmes. The four major components of any Access®-based database management system that most database users will encounter are tables, queries, forms and reports.

Tables comprise the fundamental building blocks of any database. If you’re familiar with spreadsheets, you’ll find database tables extremely similar, e.g. the example of a table

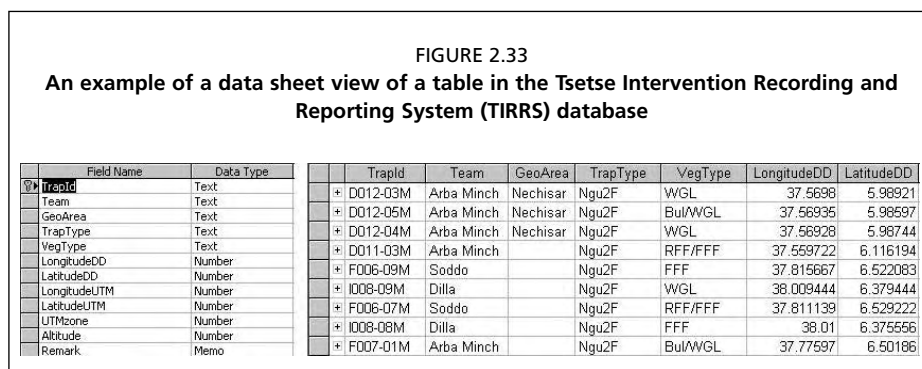

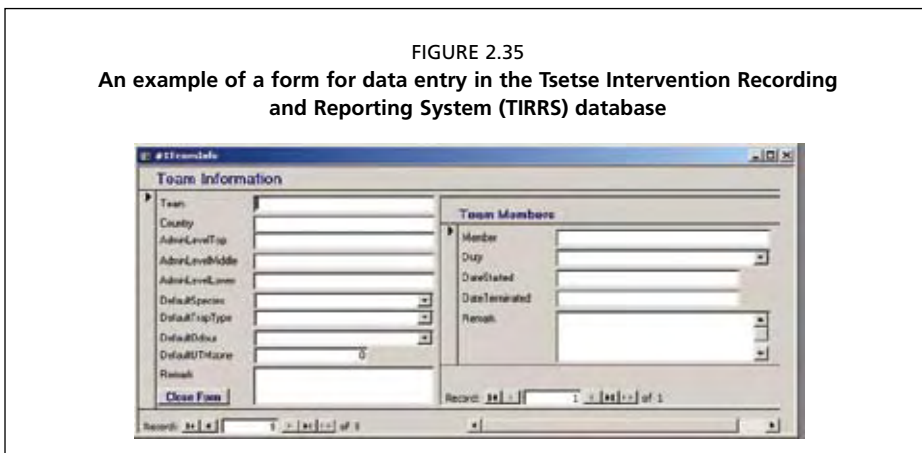
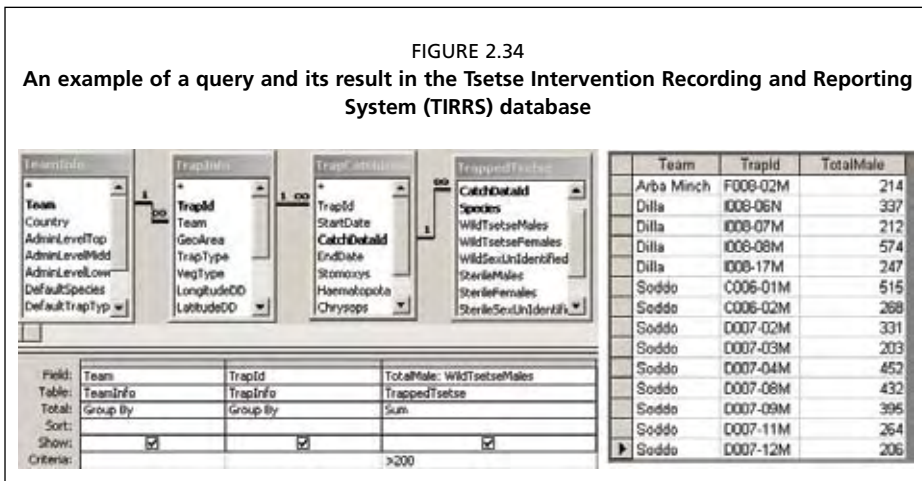

design and its datasheet from the TIRRS system (**Figure 2.33**). The table in **Figure 2.33** contains the trap identification information like longitude, latitude, trap type and vegetation type. Each column of the table corresponds to a specific trap identification (trap ID) characteristic (or attribute in database terms). Each row corresponds to one particular trap ID and contains its information.

Queries provide the capability to combine data from multiple tables and place specific conditions on the data retrieved. Looking again at the TIRRS database, suppose that we need to create a list of those trap sites whose altitude range is between 1300 and 1700 m. A simple query allows us to request that information and the system returns those records that meet the above condition. Additionally, you can instruct the database to only list specific attributes such as the grid no, trap ID, and altitude. A sample query and its corresponding output are shown in **Figure 2.34**.

Forms provide a user-friendly interface that allows users to enter data in a graphical form and have that data transferred to the database. **Figure 2.35** provides an example of a form for data entry.

FIGURE 2.36
An example of a report taken from the Tsetse Intervention Recording and Reporting System (TIRRS) database

Periodic Monitoring Report by Grid, VegType and Species										Ethiopia/Dilla	
Species	TrapId	Altitude	W. Male	AD W. Male	W. Female	AD W. Female	W. Unidentified	Total	AD Total		
Period (Cycle): 11/2005 Grid: H010											
Grassland											
<i>G. pallidipes</i>	H010-01	1256	1	0,333	2	0,667	0	3	1,000		
	H010-01	1256	2	0,667	1	0,333	0	3	1,000		
	Total/Avg	1256	3	0,500	3	0,500	0	6	1,000		
<i>G. fuscipes fuscipes</i>	H010-01	1256	0	0,000	0	0,000	0	0	0,000		
	H010-01	1256	0	0,000	0	0,000	0	0	0,000		
	Total/Avg	1256	0	0,000	0	0,000	0	0	0,000		
Woody grassland											
<i>G. pallidipes</i>	H010-01	1227	3	1,000	3	1,667	0	6	2,667		
	H010-01	1227	2	0,667	4	1,333	0	6	2,000		
	H010-03	1239	1	0,333	0	0,000	0	1	0,333		
	H010-03	1239	0	0,000	0	0,000	0	0	0,000		
	H010-06	1320	3	1,000	4	1,333	0	7	2,333		
	H010-06	1320	0	0,000	0	0,000	0	0	0,000		
	H010-07	1350	0	0,000	0	0,000	0	0	0,000		
	H010-07	1350	1	0,333	5	1,667	0	6	2,000		
	Total/Avg	1284	10	0,417	18	0,750	0	28	1,167		

Reports provide the capability to quickly produce formatted summaries of the data contained in one or more tables and/or queries. Reports allow us the inclusion of graphics, attractive formatting and pagination. Look at the example report in **Figure 2.36** taken from the TIRRS database.

Relationships between data in different tables allow us to correlate data in many ways and to ensure the consistency (referential integrity) of these data from table to table, as illustrated in the example of **Figure 2.37** of part of the TIRRS database relationships.

Notice, for example, that each trap ID is associated with a specific grid; each trapping period is associated with specific trap ID data, etc. The lines running from one table to another indicate a one-to-many or one-to-one relationship between the tables. Once the

FIGURE 2.37
Diagram showing a portion of the relationships between tables in the Tsetse Intervention Recording and Reporting System (TIRRS) database

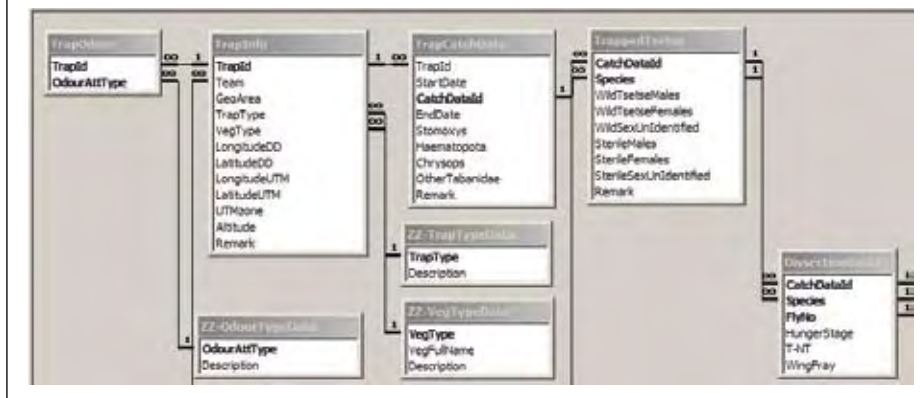

relationship is established, the database will ensure that only values corresponding to valid data in one table can be inserted in the other table. Additionally, we have the option of instructing the database to remove a record from a table on one side of the relation and then remove or update all associated records on the other sides throughout the hierarchy.

2.4.4.4. Data Recording Sheets

Examples of survey recording sheets, indicating the essential data that should be recorded are shown in **Tables 2.6** and **2.7**. Most importantly, recording sheets should show the locations of the traps from which the data were obtained. This consists of the identification of the trap ID of the given trap; the identification of the grid square in which the trap is located and next the exact position of the trap given as geographical coordinates. The most useful coordinates to be used are latitude and longitude expressed as decimal degrees or UTM coordinates. If UTM geographical coordinates are being used then the UTM zone, which covers a large area, should also be recorded. As this information is fixed for a large area, it therefore only needs to be recorded once, and not on each trapping occasion. Each trap will thus have a unique identifying number or combination of letters and numbers and corresponding coordinates (latitude and longitude expressed either as decimal degrees or UTM Eastings and Northings). It is advisable to use different recording sheets for different grid numbers. The dates of capture must be recorded. Next come the details of the tsetse and biting flies that have been captured. The type of details recorded for tsetse flies may differ from project to project, and can either consist of summarized catch data, i.e. total number of males and total number of females per trap per day (**Table 2.6**), or can be detailed for each fly, noting its sex and the results of dissection for trypanosome infection or ovarian age on the same sheet (**Table 2.7**). Most importantly, duplication of work by unnecessarily entering the same data more than once, increasing the chance of data-entry errors, should be avoided.

Data for dissection results have to be entered for each individual fly and infection types and rates will be calculated using queries.

2.4.4.5. Using the TIRRS

The TIRRS is designed to be used by three groups of people with different levels of expertise in database use and different responsibilities in the pest management programme. These groups are data entry personnel or trap site survey workers, data managers and database experts.

Data entry personnel or trap site survey workers use the graphic interfaces and menu items customized to fit in to their interests and their needs. Users in this category are allowed to interact only with the interfacing items so that they do activities that are limited to those that are given in the TIRRS menu. They should be allowed to have access only to the MDE¹ file version of the TIRRS.

¹ MDE: Microsoft Access Database: Microsoft Access database file with all modules compiled and all editable source code removed. In MDE file all Visual BASIC for Applications (VBA) procedures are compiled — converted from human-readable code to a format that only the computer understands. This change prevents a database user from reading or changing your VBA code. No one can create forms or reports or modify the existing ones but can create queries.

TABLE 2.7.
An example of a recording sheet to enter data of tsetse dissections.

Tsetse Dissection Sheet

Dissector _____

Mag. WVL _____

Mag. Ovariole _____

Date of entry _____

No.	Date	Trap site	System	Species	Sex	T/NT*	F.N.O.S.**	No. of ovulations	Ovariole sizes			
									largest		second	
									length	width	length	width
1												
2												
3												
4												
5												
6												
7												
8												
9												

* T – Teneral, NT – Non Teneral

** Follicle Next in Ovulation Sequence

Data managers are persons with a good background and knowledge of using database management systems in general and Microsoft Access® in particular. They are advised to work only on MDE versions of TIRRS. They will be responsible to extend the use of TIRRS by:

- creating new queries according to new requirements,
- importing and merging data collected from different areas,
- making backup and restoring data from backups,
- making sure that data collection sheets are used in a proper manner,
- supervising the data-entry process and device mechanisms of minimizing errors,
- training the data-entry personnel on how to use TIRRS,
- assisting the data-entry process and solving related day-to-day problems, and
- dealing with all other TIRRS related activities and problems.

Database experts are persons with a solid background and knowledge of database design and programming. Such persons must be able to read and understand others work (programme and design) so that they can suggest necessary changes. All database related problems and new requirements that are beyond the capacity of the data manager are to be dealt with by such experts. They can work both on MDE and MDB² versions of TIRRS but any change on the structure of the system must be well documented and reported to the central office before its redistribution to the users. Care should be taken when changing components of MDB file. Organizing a new testing scheme may be necessary after the new change on MDB components so as to make sure that the changes are done according to need. Major duties will be:

- designing new or redesigning existing components of the system so that they fit to new requirements,
- caution: if the changes involve the MDB version of TIRRS, compilation into MDE and transfer (importing) of all data tables in previous MDE to the new MDE is necessary before distributing the system to the end users,
- assisting the database manager in solving prevailing problems,
- dealing with all other TIRRS problems encountered by the users and the data manager, and
- documenting any changes made to the structure of TIRRS.

2.4.4.6. TIRRS Menu System

The TIRRS menu system is organized into hierarchies of menu items organized into groups and subgroups. In this section, we will look at the components and the purposes of each of the menus and the menu items.

TIRRS start-up screen — This is the main screen that appears when we start TIRRS. It has four buttons to choose from, i.e. (1) a button to continue working in TIRRS system, (2) a button to create a table of the apparent density of tsetse flies for each trap (expressed as the average number of tsetse of each species caught per trap per day) for further GIS

2 MDB: Microsoft Access Database File

FIGURE 2.38
Main start-up screen of the Tsetse Intervention Recording and Reporting System (TIRRS) database

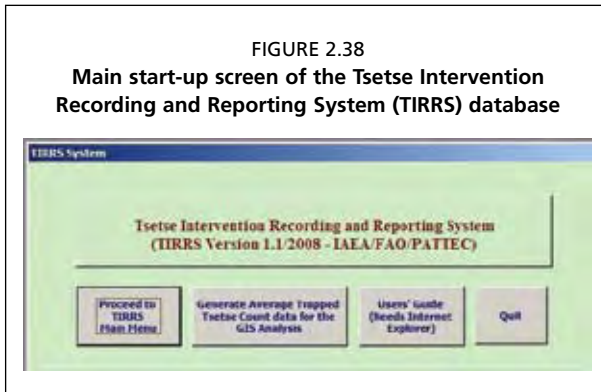

FIGURE 2.39
Pop-up box for setting condition to generate data for GIS in the Tsetse Intervention Recording and Reporting System (TIRRS) database

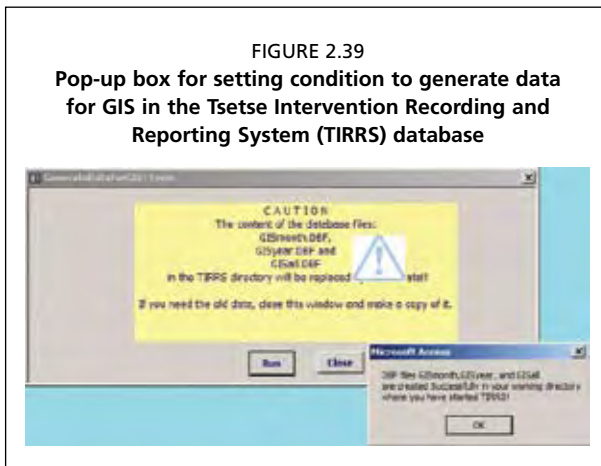
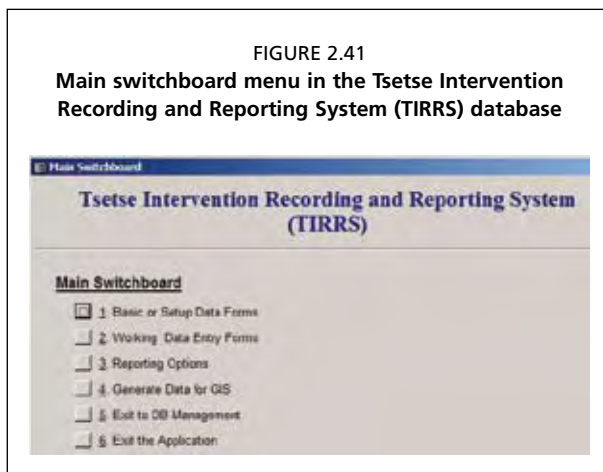

FIGURE 2.40
A sample of the table output in the Tsetse Intervention Recording and Reporting System (TIRRS) database used as an input for GIS analysis

Cycle	Species	Longitude	Latitude	ADmale	ADfemale	ADboth
1 G	palldipes	37.31920E	5.705380	0.000	0.333	0.333
2 G	f. fascipes	37.31920E	5.705380	0.333	2.000	2.333
1 G	f. fascipes	37.31896E	5.705180	0.000	0.333	0.333



analysis, (3) a button to read this user guide, and (4) a button to exit from the system (Figure 2.38).

The “Proceed to TIRRS Main Menu” button in the figure is the one that takes us to all hierarchies of available options in TIRRS. The “Generate Average Trapped Tsetse Count Data for the GIS Analysis” button takes us to another small popup window in which we select the period of trapping and tsetse species for which we want to generate a resource table for GIS analysis. Look at the figure of this popup in Figure 2.39.

The type and content of the table that we get as an output from this process and that will be used as an input by the GIS is given in Figure 2.40

Main switchboard menu — The first menu that we get after clicking the TIRRS option is the “Main Switchboard” menu. It consists of submenu items indicated in Figure 2.41.

Under the main switchboard menu select:

1. The submenu for basic/setup data forms. Data in this category is entered at the setup level before the working data is to be entered. It can be extended any time. Examples are; list of species available, type of vegetation, type of trap used, team related data, etc.;
2. The submenu for working data entry forms;
3. The submenu for displaying/printing ready-made reports (reporting options);
4. The submenu to generate aggregated data for GIS analysis;
5. The submenu to exit to Microsoft Access® environment where data managers or database experts can make changes to some of the components of the TIRRS or perform other activities like querying the database, etc., and
6. The submenu to exit TIRRS.

Data entry forms menu — This menu consists of submenus for basic data entry (Figure 2.42) and working data entry (Figure 2.43). The forms are also linked to each other and therefore we can, for example, access the “trap ID” form from within the “grid” form; similarly “trapping occasion” “site instance” from “trap site”, etc. This method of access-

FIGURE 2.42
Menu in the Tsetse Intervention Recording and Reporting System (TIIRS) database to select setup data entry forms

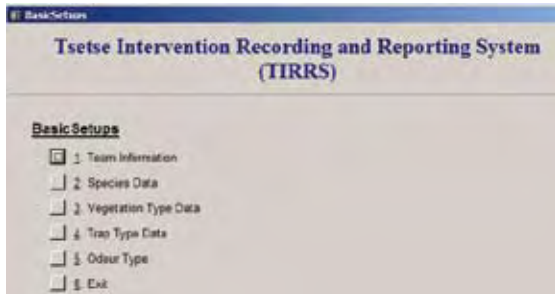

FIGURE 2.43
Menu in the Tsetse Intervention Recording and Reporting System (TIIRS) database to select working data entry forms

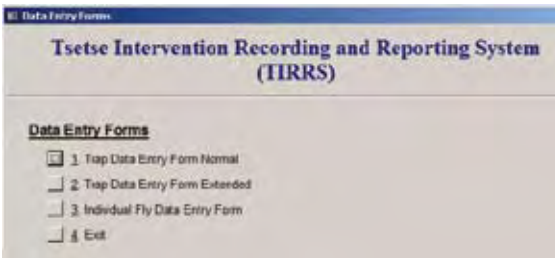

FIGURE 2.44
Menu in the Tsetse Intervention Recording and Reporting System (TIIRS) database to select reporting options



related to our current recording. While, for example, working on fly dissection data entry of flies from specific trap site, the system limits us to work only in that particular grid and trap site.

- The use of auto entry of values by calculating from already existing data: some data such as the number of trapped flies, should be normalized to the per-day rate as trapping, for different reasons, may extend to more than one day. In this case, the system uses starting and ending date information to calculate the number of days. And then normalize the number of flies captured to the per-day count, and
- The use of option buttons and check boxes: option buttons and check boxes are used to avoid confusion on a complex entry form. In the TIRRS the trap info data entry form, for example, is equipped with such features (**Figure 2.47**).

2.4.4.8. Reports in the TIRRS

The TIRRS has many ready-made reports to show trends, summarize data, and tabulate values. All the reports that were envisaged during the design of the system are categorized and listed under the reports submenu of the TIRRS switchboard menu. Once the data is in the TIRRS, anyone with some knowledge of database management (in our case the data manager) can create any report of interest. Categories of the currently added reports include: trap density, dissection, population structure, reproductive structure, and other customized reports that summarize and tabulate different data by parameters like vegetation type, altitude range, trap type, type of odour attractant, etc.

The report shown in **Figure 2.48**, for example shows the average daily fly catch for a given trap for six tsetse species recorded (hypothetical data). All other necessary information is added to the report to make it more readable and understandable.

This type of report can be printed by entering specific conditions in the report setting a popup window (**Figure 2.49**) that is displayed when selecting any report item. We have several such types of ready-made reports that can be accessed from the report menu.

2.4.4.9. Backing Up the Database

Most people using computers know that they should back up their work in case something happens to their computer, or to the data file, yet many people still do not do this. For some types of work it may not have important consequences if it is lost, but for a large database, taking a lot of time to enter, it is essential that backups are made regularly so that the data is not lost, as this could create a serious set-back to planning and implementation. It is recommended that weekly backups of the database constructed using TIRRS are made on CDs, on external hard drives, or, where available on a server. Most PC's now come with an in-built CD/DVD writer and using rewriteable CDs and making CD backups is neither difficult nor costly. A copy of the database should also be stored in a separate, headquarters office as well as at the project site office. To take a backup of data in the TIRRS, we use the backup option of the Microsoft Access® itself.

Steps for making a backup

1. Save and close all objects in the database.
2. On the File menu, click Backup Database.

FIGURE 2.48
Sample report of period monitoring by grid and species in the Tsetse Intervention Recording and Reporting System (TIRRS)

Periodic Monitoring Report by Grid and Species										Ethiopia/Soddo
Period (Cycle):	TrapId	Veg Typ	Altitude	W. Male	ADW. Male	W. Female	ADW. Female	W. Unidentified	Total	AD Total
9/2005		Grid: C005								
<i>G. pallidipes</i>										
	C005-01M	RFFFFF	1375	1	0,333	2	0,667	0	3	1,000
	C005-02M	RFFFFF	1356	1	0,333	1	0,333	0	2	0,667
	C005-03M	RFFFFF	1267	2	0,667	4	1,333	0	6	2,000
	C005-04M	Bul'WGL	1392	0	0,000	2	0,667	0	2	0,667
	C005-05M	Bul'WGL	1346	0	0,000	1	0,333	0	1	0,333
	C005-06M	Bul'WGL	1345	0	0,000	0	0,000	0	0	0,000
	C005-07M	Bul'WGL	1359	0	0,000	0	0,000	0	0	0,000
	C005-08M	Bul'WGL	1265	15	5,000	38	12,000	0	53	17,000
	C005-09M	Bul'WGL	1264	43	14,333	36	12,000	0	79	26,333
	C005-10M	Bul'WGL	1346	44	14,667	48	16,000	0	92	30,667
Total catches & Average ADs			1332	106	3,533	132	4,400	0	238	7,933
<i>G. fuscipes fuscipes</i>										
	C005-01M	RFFFFF	1375	2	0,667	5	1,667	0	7	2,333
	C005-02M	RFFFFF	1356	0	0,000	1	0,333	0	1	0,333
	C005-03M	RFFFFF	1267	1	0,333	1	0,333	0	2	0,667
	C005-04M	Bul'WGL	1392	0	0,000	0	0,000	0	0	0,000
	C005-05M	Bul'WGL	1346	0	0,000	0	0,000	0	0	0,000
	C005-06M	Bul'WGL	1345	0	0,000	0	0,000	0	0	0,000
	C005-07M	Bul'WGL	1359	0	0,000	0	0,000	0	0	0,000
	C005-08M	Bul'WGL	1265	0	0,000	0	0,000	0	0	0,000
	C005-09M	Bul'WGL	1264	0	0,000	0	0,000	0	0	0,000
	C005-10M	Bul'WGL	1346	0	0,000	0	0,000	0	0	0,000
Total catches & Average ADs			1332	3	0,100	7	0,233	0	10	0,333

Filter Conditions Used (" means all): Country=Ethiopia, Team=Soddo, Grid=, Trap=, VegType=, Altitude(from)=, Altitude(to)=, StartDate(from)=, StartDate(to)=, Species=

FIGURE 2.49
Pop-up window to set conditions for all reports in the Tsetse Intervention Recording and Reporting System (TIRRS)

3. In the Save Backup As dialog box, specify the name and location of the backup copy.

Restoring the backed-up data — Use the explorer to copy the backup database to your database folder. If the existing database in the database folder and the backup copy has the

same name, restoring the backup copy may replace the existing file. If you want to save the existing file, rename it before you copy the backup database. The TIRRS database contains objects such as tables, queries, forms, reports, macros, and modules. Sometimes, it is possible to import only selected objects we want from the backup to our working copy.

2.4.4.10. Entomological Considerations Regarding the Database

This section provides some explanation for the construction of aspects of the database and the way it should be used. The database is constructed to accommodate the recording, storing and manipulation of all the theoretically desirable entomological data for conducting an AW-IPM programme. It is recognized, however, that not all projects will have the capacity and resources to collect all such data, or maybe perhaps only for limited periods of time. Similarly, for some projects certain aspects may be considered unnecessary. For this reason certain forms will have sections that can be selected or deselected such as the forms for recording reproductive details of female flies including ovarian age. This is a dissection requiring considerable skill and experience that may not always be available and may be required for specific phases of a project.

Identification of project staff — In relation to dissection, as well as other activities in the catching, managing and recording of fly details it is sometimes useful to record the names of the persons carrying out specific tasks so that queries can be made to the appropriate person if necessary at a later date. It would be inconvenient, however, to record the dissector of each individual fly: in some cases this could remain constant for a long period, or in others there may be several persons who could perform the task over a short period of time. The database is therefore designed to provide the names of members of a field team and it is expected that team leaders or supervisors will be able to use this information to assess the data or request verification as and when required.

Defining a trap identification — Tsetse trap data refers to a specific set of trapping conditions (trap type, type of odour attractants and dispensers); this allows comparisons to be made between catches at different time intervals. If some of those conditions change, a reliable comparison may not be possible. For example, one cannot compare catches with a biconical trap with attractants with catches from one without attractants unless some correction is made for the effectiveness of an attractant. Similarly, a comparison between catches from a biconical trap and an F3 trap cannot be made directly because the traps have different efficiencies. For these reasons, if there is some significant change in the trap data over time, it is preferable to give the changed trap a new unique trap ID rather than to record it as the same trap with some modifications – even if its geographical location has not changed.

The database contains a drop-down list of trap types; if additional trap types are to be used, they must first be added to the trap type list (Table zz-Traptypedataform) before they will be accepted in the database when entered in the trap ID form.

Also included as a dropdown list is a selection of vegetation types with a description of how they are defined. Additional vegetation types may be added together with their descriptions if required. The FAO AfriCover project lists a large number of vegetation types

but such an exhaustive list would be unsuitable for use on a tsetse survey in which a rapid determination has to be made, by entomologists with a minimum necessary amount of training in this area. Ideally, there should be a fixed number of standardized vegetation types and recently, FAO has customized the various vegetation types of the AfriCover project for use in tsetse projects (Cechi and Mattioli 2007, Cechi et al. 2008). Vegetation types may change over time if areas of forest in which traps have been deployed are cleared. This must be taken into account when analysing and comparing results over time. If necessary, a trap needs to be re-identified (given a new identification) if the vegetation has changed significantly.

Defining a trapping period — It is common practice to carry out a period of trapping, say for three days, and to calculate the apparent density, expressed as the number of tsetse of a particular species caught per trap per day, by simply totalling the number of tsetse of that species that have been caught and dividing the total by the product of the number of trapping days and the number of traps used to catch them. The number of traps could be one if a figure of apparent density for an individual trap is required, but more commonly is for a group of traps in a given location such as a village or a grid square, etc. It would be more precise to take into account the number of hours that a trap has been in position. It is logistically unlikely to be possible to put out a series of traps all at the same time and to collect the catch from each trap all at the same time.

Commonly, a team will deploy a number of traps, starting with the first early in the morning and finishing with the last after a considerable time has elapsed, perhaps even late in the afternoon. This has implications for the interpretation of catch results not only because of the difference in length of time that a trap might be deployed but also in relation to the activity cycles of tsetse. This is complicated by the fact that activity cycles can vary seasonally throughout the year with temperature, etc. There is commonly an activity cycle in the late afternoon/early evening. Thus, a trap that has been deployed for three days and is “harvested” early in the morning on the third day, might miss the final day’s activity cycle compared to the last trap to be harvested that may not be visited until late in the afternoon and that will have caught flies in the afternoon activity cycle. Whilst this might not be significant for a one-off survey determining where tsetse is found, it could be significant during the monitoring of the suppression or eradication phase of a project. The TIRRS database has been designed to incorporate the start- and end-times of a trapping period and to calculate the apparent density corrected for the number of hours of trapping but it cannot interpret the results in relation to activity cycles – that has to be done by the project entomologist. The TIRRS programme will allow the user to leave the times blank if those data are not recorded but will automatically enter a default “start time” of 08.00 a.m. for the start of trapping for the purposes of calculating the apparent density. Aspects of activity cycles and trapping duration are discussed elsewhere in the survey manual.

Geographical coordinates — Although a particular coordinate system can be recommended (e.g. decimal degrees), the TIRRS allows some flexibility to take into account project preferences for coordinate systems and it is possible to select between UTM or decimal degrees as the two major alternative systems that are expected to be used. With

ArcGIS® software, data from either system can easily be projected on the same map, with the projection conversion being made automatically by the GIS software.

Use of a grid system — The reasons for using a grid system for organizing a tsetse survey in the context of AW-IPM have been discussed and described in 2.4.3.1 of these guidelines. The grid structure is used to aid the planning and organization of logistic aspects of a project; data need not be analysed or displayed on a GIS map following a grid-based structure, although this is possible. As explained in this manual, although commonly based on the UTM 10 × 10 km grids found printed on paper maps, the identification of grid squares for a project is arbitrary, usually based on columns identified with letters starting with “A” and rows identified with numbers starting with “1”. This structure allows the rough location of traps to be identified visually on a hardcopy map (within a grid square), which is less easily done with numerical geographical coordinates, although the latter allow the precise determination of their position. The grid structure is incorporated into the TIRRS database to allow a basis for dividing trapping results into spatial units for analysis. The same analyses can also be carried out for individual traps or for administrative units such as villages or similar artificial but identifiable geographical locations as well as by natural features such as vegetation or altitude.

FIGURE 2.50
A form in the Tsetse Intervention Recording and Reporting System (TIRRS) that shows GIS query choices

GenerateDataforGIS: Form

Enter duration and species for which you want to generate Table for GIS analysis

Report Starting Date: 01/06/2003

Report Ending Date: 30/07/2003

Species Name: Glossina austeni

CAUTION: The content of the table with name GISdata in the TIRRS database will be replaced by the new content that is based on these conditions.

Run Close

FIGURE 2.51
A form in the Tsetse Intervention Recording and Reporting System (TIRRS) that allows the creation of a new table of tsetse trap data for GIS

GenerateDataforGIS: Form

TIRRS: System

You are about to paste 29 row(s) into a new table. Once you click Yes, you can't use the Undo command to reverse the changes. Are you sure you want to create a new table with the selected records?

Yes No

Species Name: Glossina austeni

CAUTION: The content of the table with name GISdata in the TIRRS database will be replaced by the new content that is based on these conditions.

Run Close

FIGURE 2.52
View of the “Add Data” button in ArcView® that can be used to choose a table from Access® database

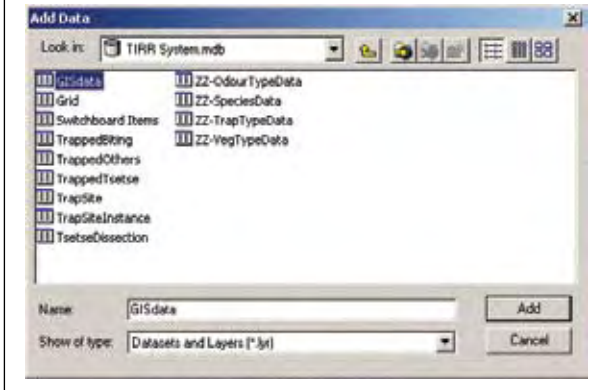
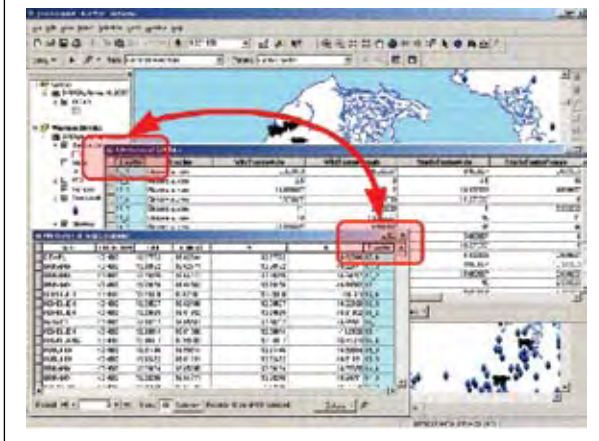

FIGURE 2.53
View in ArcView® GIS of the trap layer table of attributes joined to the Access® table of capture data by linking the “Trap No” field



2.4.4.11. Connecting the Database to GIS

The GIS program maintains a permanent layer of trap locations. Each trap has a unique ID number (or name). Within the database all capture data use the exact same unique trap ID number as an index for the capture data. Then when new data is brought into the GIS, a link is created between the trap’s geographic location (GIS layer) and the updated capture data (tabular data table). This link is based on the matching trap ID numbers. It is crucial to keep these two sets of trap ID numbers synchronized. Normally synchronization will be maintained by first placing traps in the field and using a GPS instrument to georeference

the location. Then the GPS data file will be downloaded to the computer, and displayed in the GIS program. Finally, using the GIS layer of traps, a table of trap ID numbers will be extracted, or exported, to the database application. As the project progresses and new traps are added, they also will be georeferenced with a GPS instrument, and again an updated table of trap ID numbers will be exported to the database, thus keeping the two tables in sync.

Secondary information that will be obtained from the survey includes:

- The relationship between tsetse distribution/abundance and environmental characteristics (e.g. vegetation, altitude, temperature, relative humidity, rainfall). A requirement for analysing that information is an up-to-date vegetation/land use map, or satellite imagery from which it can be obtained and local, contemporary meteorological data.
- The mean apparent density per tsetse species per month (can also be split by sex) interpolated over the project region.
- Trypanosome infection rates in tsetse, and
- Age structure of the population.

The TIRRS main menu offers a button (**Figure 2.38**) for creating a GIS-specific table to be used to display tsetse capture data on a map as follows:

1. Be sure the trap ID number in the TIRRS table of traps is synchronized with the GIS layer of traps;
2. Run the above query, indicating the period of time (start date and end date) as well as the species of tsetse desired (**Figure 2.50** and **Figure 2.51**);
3. Within ArcView GIS, add the table "GISData" from the TIRRS database file (*.mdb) to the GIS project (**Figure 2.52**);
4. Create a join between the GIS trap layer, and the TIRRS table of average trapped flies (**Figure 2.53**);
5. use the GIS symbology tools to display the capture data (see 2.4.1.2).

2.4.5. Sensitizing the Local Population

It is important to sensitize and inform the rural population in the area of the survey in order to make them aware of what is going on and why. Unless this is done, the communities in the area will observe the activities being carried out, and the tools (traps) being used but will not be aware of the reasons or the significance. Lack of awareness can result in lack of cooperation and traps being stolen or damaged, thus disrupting the survey implementation. It is equally necessary to inform local government authorities of activities that are to be carried out in their area even if central government departments are aware of, and involved in the project.

This essential phase should be done in two phases:

1. The responsible person from the national authorities/local project management staff should contact all the relevant local government leaders at different levels to explain the objectives, type and locations of activities and the timing of events that will take place in the area,

2. During a second phase of sensitization, carried out at a local level during field operations, the field teams will inform the people living in the immediate vicinity of field operations of the activities, their importance and relevance to the community and the potential benefits. This information will be best disseminated in the local language and will seek the cooperation, and often, the active participation of the villagers for example in maintaining a trap in functioning condition.

2.4.6. Management of Resources

During the preparatory phase, after determining where the project is to take place and prior to the detailed planning and start of operations it will be necessary to establish a project team both to manage and implement the activities. When established, that team will carry out the other preparatory phase activities such as preparing a detailed budget, procuring equipment (e.g. the number, type and source of tsetse traps, the most appropriate type of odour attractants required and their acquisition, compound and dissecting microscopes, drying ovens, desiccators, photocopier, printers, GPS instruments, maps, satellite images, etc.), needs in terms of human resources (field team size and composition) and preparing detailed work plans for implementation.

2.4.6.1. Human Resources: Establishing a Project Team

When planning the type of team required it is necessary to consider all of the tasks that will have to be undertaken and who will carry them out. For example, traps and cages will need regular supervision and repair – who will carry that out? The survey teams will probably be coming back late from the field and leaving early in the morning on a fixed schedule. If consideration isn't given to who will maintain the traps it may well be left inadequately done, and yet this seemingly minor component is crucial for the success of the survey. Who will maintain records of the available consumables and other items needed for keeping the work progressing on schedule? Will it be the project manager when he has some free time from providing technical supervision or will that lead to delays in replenishing essen-

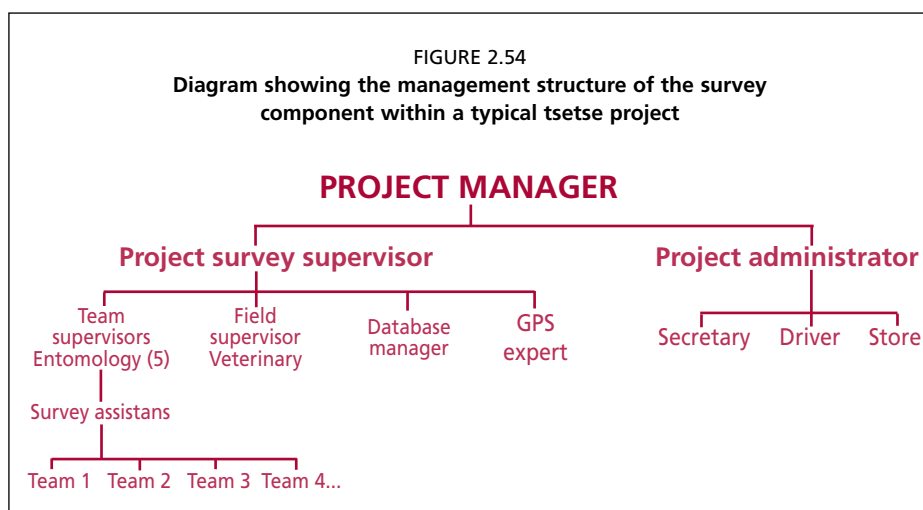

tial items? Who will be responsible if things are not available when required? Inevitably problems will arise if these things are not planned for and if each person's job description is not clear. Job descriptions should be clearly defined and provided to each team member, and where possible, check lists should be provided, and handed to supervisors monthly, to ensure that the necessary tasks have been fulfilled.

Project management unit — The size of the project management team will, of course depend upon the size of the project, which will be reflected in the budget available. For large projects there may be a large project management team, whereas, for a small project a smaller project management team will comprise staff having multiple functions. For example, the administrator might also be responsible for the store and the role of cashier. The overall manager would be a person with technical expertise, but also having good management capability (Dyck et al. 2005).

Project manager — Responsible for all aspects of the project, including the administrative management, procurement, recruiting staff, etc. Management staff should allow technical staff to make use of their technical expertise rather than to have too much involvement in administrative matters. The senior technical staff should make technical decisions on survey implementation.

Project survey supervisor — A qualified tsetse entomologist with experience in tsetse surveys will be responsible for the planning and implementation of the survey, providing technical backup and support to field teams. The project survey supervisor reports to the project manager.

Database manager — Expertise will be required in the initial stages for establishing a database and training project staff in its use, unless an off-the-shelf database is available that does not need adapting. In the latter case there will still be a training requirement to ensure that it is correctly used. Expertise will also be required for analysis of the data, although if a ready-made data management system with querying and reporting mechanisms is available those requirements will be minimal. The database manager will provide feedback to the project manager on progress of the survey and on any queries arising from the data. The technical project manager will in turn provide feedback to field survey teams.

Data-entry person(s) — Depending on the size of the project, one or more data-entry persons will be required to enter all the data received from the field into a single master database. They will also be responsible for maintaining backups of the data and verification of the accuracy of the data entry. They will report any errors or omissions of data to the database manager so that, through the technical project manager, feedback can be provided to the field teams.

GIS expert — It is recommended that there is a GIS expert on the management team. GIS expertise and experience with entomological/epidemiological survey work is an increas-

ingly valuable asset as more GIS applications become available and as their contribution to entomological and epidemiological work becomes more apparent (Cox and Vreysen 2005). At a minimum, a short-term GIS expert will be required at certain stages of the project. The GIS expert will provide not only maps, but interpretation of satellite images, analysis and interpretation of field data (correlations between tsetse catches and environmental factors – habitat, vegetation, altitude, etc.) – and will be able to contribute to predictions of areas of suitability for tsetse that might require additional surveying. It may also be desirable to commission specific detailed GIS analyses by specialists from external sources such as universities, national or international organizations or consulting companies.

Secretary — Required for normal secretarial duties.

Driver — Although the project managers and other staff may be able to drive themselves, it is likely that a driver will be required for the management unit. The driver will be responsible for ensuring that the vehicles are maintained and roadworthy.

Survey teams — Each survey team will require a driver or a member of the team responsible for driving the vehicle (however many teams there are). Ideally, the driver should also participate in the other survey activities — deploying the traps, etc. Trap assistants,

TABLE 2.8
Equipment and consumables with associated costs required for a large-scale (10 000 km²) tsetse survey.

	Number	Unit price	Total (USD)
<i>Transport</i>			
Vehicles (coordinator and tsetse teams)	6	25 000	150 000
Fuel (200 km per day per survey vehicle; 15 km/litre + coordinator = 22 500 litres/year)	22 500	0.9	20 250
Oil (500 litres)			750
Fuel and oil filters (72 +72)			1100
<i>Tsetse survey</i>			
Traps (20 per team/day)	500	7	3500
Cages	1000	2	2000
Slides box of 150	5000		200
Cover slips (10 000)			100
Dissecting instruments	15	100	1500
Dissecting microscopes	5	6000	30 000
Compound microscopes	5	9000	45 000
GPS instruments	6	300	1800
Satellite imagery			700
Portable generators	5	400	2000

<i>Stationery and office equipment</i>			
Computer – GIS + software	1	1500	1500
Computer per team	5	1500	7500
Computer survey tsetse data	1	1500	1500
Computer for coordination / administration / communications	1	1500	1500
A3 Colour printer	1	500	500
A4 Laser printer	1	500	500
UPS	8	200	1600
Communications (telephone / email / internet, fax)			3000
Paper			150
Printer ink cartridges			1000
Computer software — Data management software such as Microsoft Access or "TIRRS"; GIS software			6000
Photocopier	1		1200
<i>Personnel</i>			
Coordinator / Office manager	1	5000	5000
Survey supervisor (entomologist)	1	5000	5000
Drivers	6	3086	18 516
Field entomologists	5	4937	24 686
Technicians	15	3086	46 286
Secretary	1	3000	3000
Data entry	2	3000	6000

technicians (whatever the terminology) will deploy traps, collect flies, dissect the flies, and record the data. The number will depend upon the size of the area to be surveyed, funding available, etc. For a large survey, this might range from 10 to 20, divided up into four or five teams up to as many as 40 persons in ten teams for an area of 10 000 km², which is probably about the maximum area that could practically be surveyed at one time.

Each team should include a tsetse entomologist supervisor who has sufficient experience in addition to a higher level of training, and who is capable of supervising the identification of good appropriate trap deployment sites, following the survey plan protocol that will be prepared by the technical project manager in consultation with other senior technical staff.

2.4.6.2. Budget Preparation and Procurement of Equipment

Having determined the team composition and prepared a list of materials/equipment and services that are going to be required it will be necessary to prepare a more precise budget

than what was prepared in the project formulation stage. The budget will depend on many factors, especially the size of the area to be surveyed and the time scale for the activities.

Table 2.8 shows an example of the sort of materials and quantities that might be required for a large-scale survey of 10 000 km² as a guide. Costs of the materials and equipment listed will vary with time and country and are therefore not to be taken as actual cost guidelines. Furthermore, it does not include some of the highly variable costs such as renting or constructing office buildings, electricity, water or other utility consumption costs.

Procurement of equipment from overseas can take much longer than expected if bureaucratic procedures have to be followed, involving international tenders and combinations of both national government and donor regulations. Although this point might seem unnecessarily obvious, it is important to start procedures as early as possible and to become familiar with, and follow established regulations and procedures closely if equipment is to be available at the time it is required. There are examples of delays in procurement in tsetse/rural development projects with a limited period of funding that have resulted in vehicles being delivered in the final months of the project. (Similarly, inadequate planning and preparation has resulted in instances of baseline survey reports only being available in the last month of a project).

2.4.6.3. Training

Training will be required for project personnel on tsetse biology, ecology, survey techniques, map reading, data management, and GIS. Although people will generally be recruited who already have some technical knowledge, short training workshops will be necessary to ensure that standardized methodologies are used – people coming from different former projects often have their own way of doing things that may differ. Furthermore, with ever-increasing knowledge of tsetse behaviour, trapping technologies, including further development of odour attractants, it is essential that opportunities are given for staff to be able to refresh their knowledge. Emphasis will be on practical aspects that are required for the efficient and effective conduct of the survey. The most basic and essential aspects for which training will be necessary will include:

- an understanding of tsetse ecology and biology, needed to aid the identification of appropriate habitats and locations for traps as well as the behaviour of tsetse in relation to traps and odours and patterns of activity,
- aspects of trap deployment – the need for standardization of procedures and trap design,
- map reading and use of GPS instruments,
- data recording and database management, and
- GIS.

For the team responsible for dissection of tsetse specialised technical training will be required on:

- identification and sexing of tsetse,
- wing fray ageing,
- ovarian dissection and ageing,
- dissection for detection of trypanosome infections, and

Section 3

Implementation of a Baseline Data Survey

3.1. SAMPLING DEVICES

3.1.1. Traps

3.1.1.1. Trap Types

A variety of traps have been designed to catch different species of tsetse, and a variety of odour attractants are available that can be used to make the traps more efficient. Traps and attractants for a given species may function differently in different locations, sometimes because of differences in behaviour of genetically different populations of that species or due to different environmental factors. The types of trap available and an indication of their efficiency for those species for which the trap has been tested are given in **Table 3.1**. Similarly, **Table 3.2** and **Table 3.3** indicate the effectiveness of different odour attractants against species of tsetse flies for which they have been tested in East, West and southern Africa (Kuzoe and Schofield 2005). Some of the recently identified attractants listed in these tables have not yet been widely tested or utilized. When selecting an odour attractant, one must not only consider its index of increase in performance of the trap but economics and practicality. It should also be noted that the indices of increase are obtained comparing specific trapping systems in specific areas and can therefore only be used as a rough guide.

The predominant trap designs in current use are described and illustrated below, and their efficacies for the different species are compared.

Biconical trap (Challier and Laveissière 1973, Challier et al. 1977)

The biconical trap (**Figure 3.1a**) was developed in the early 1970s for catching *Glossina palpalis* (see FAO training manual for tsetse control personnel, volume 1, section 7.2.2.2 (FAO 1982a)). It is still one of the most widely used traps and has been used extensively for sampling *Glossina palpalis palpalis*, *Glossina palpalis gambiensis*, *Glossina fuscipes* and *Glossina tachinoides*. The trap is very efficient for *G. tachinoides* but less so for *G. palpalis* and is recommended for both control and for surveys of *G. tachinoides*. The trap consists of two cones each 80 cm wide, an upper cone 73 cm high and a lower cone 60 cm high, joined at their widest point. The trap body is kept open by a metal or plastic hoop sewn into the seam where the two cones join. The blue lower cone has four entrances, approximately 30 cm high and 20 cm wide. The upper netting cone has a 12 mm hole to allow flies to enter the cage. Vertically dividing the inside of the trap is a black cruciform, which acts as

both a target and baffle. The trap is supported by a central pole, but can alternatively, be suspended from a convenient branch. That is not recommended for survey purposes as movement of the trap in wind could increase the variability of the trap catches. The weight of the trap is supported at the upper cone apex by a welded wire cone, which supports a cage (usually of the Geigy type; see FAO training manual for tsetse control personnel, volume 4, section 3.1.4 on cage designs (FAO 1992)). The trap is easily transported and deployed and for this reason may be more appropriate to use than other trap designs with slightly better efficiency but which are more difficult and time-consuming to deploy.

Monoconical trap (Lancien 1981)

Developed as a simplified biconical trap for control of *G. palpalis*, and *Glossina fuscipes quanzensis*, the blue/black monoconicals have an upper netting cone, with the same cruciform target below as the pyramidal trap. The monoconical trap has a polyvinyl chloride cone used as a rain cover for the impregnated material below (**Figure 3.1b**). Instead of a lower cone, blue streamers hang vertically from the cone rim. As in the biconical trap there is a black cruciform target; this is the same width as the cone and extends from the trap top to below the cone rim. The cone is nearly half the size of a biconical, and is self supporting. There have been many subsequent versions of monoconical traps. Type A monoconical has one screen black and the other blue, whilst type L monoconical has the central portion of each screen black and the outer portion blue. One of the better known has no blue streamers, and the cruciform target is black above the level of the cone rim and blue below. The early monoconical traps were primarily developed for control purposes but can also be used for sampling. Most trials have indicated that they catch fewer flies than the biconical.

Pyramidal trap (Lancien and Gouteux 1987)

The pyramidal trap, which was developed primarily for the control of *G. p. palpalis* and *G. f. quanzensis*, is simpler to make and cheaper than the biconical trap (Lancien and Gouteux 1987). Instead of a lower cone or streamers, one diagonal of the black cruciform target is replaced by blue (**Figure 3.1c**). The upper net cone is pyramidal with the blue and black reaching only half way to its top. If free standing, the upper part of the baffles are netting; when used with insecticide and externally suspended for control, the baffles are modified to accommodate an internal net funnel and a collector filled with diesel fuel, gas oil, as a preservative. The cone is kept open by two horizontal pieces of wood inserted diagonally across its base. Its comparative efficiency with the biconical trap varies with location, catching 2–5 times more *G. p. palpalis* in Congo, but similar numbers in Côte d'Ivoire.

Vavoua trap (Laveissière and Grébaut 1990)

The Vavoua trap (**Figure 3.1d**) was designed for control of *G. palpalis palpalis* and to be suspended or fixed to the ground with a pole. Its efficiency is similar to that of both the biconical and pyramidal traps, but it is considerably cheaper. The trap has one arm of the cruciform of the type L monoconical omitted, giving three half screens at 120° to each other. They only reach half way up into the cone and there is no netting baffle above. The net cone is held open by a hoop sewn into its rim. The trap is fixed to the ground using an iron pole, similar to that used for biconical traps although it can also be suspended. The

stick is made from 8 mm concrete reinforcing steel 1.7 m long. To keep the trap in a normal position, after installation, cut four sticks of wood, of bamboo or of any sufficiently rigid plant, to hold the screens without them breaking or bending. They must not be too heavy as the pyramid of netting becomes fragile very rapidly after exposure to the sun.

Monoscreen trap (Okoth 1991)

Developed for community-based control of *G. fuscipes*, this trap has a single half black, half blue screen reaching half way up into a small net cone (**Figure 3.1e**). Flies are collected in a Geigy-size cage. The cone is held open by a hoop sewn into its base and the trap is free standing.

Bipyramidal trap (Gouteux 1991, Gouteux et al. 1991)

The bipyramidal trap was developed in the Central African Republic (CAR) for community based control against *G. f. fuscipes* (**Figure 3.1f**). Tests in the CAR indicated that the bipyramidal trap was twice and four times as effective in trapping *G. f. fuscipes* as the biconical and monoconical trap, respectively.

F3 trap (Flint 1985)

Developed for sampling *Glossina pallidipes* and *Glossina morsitans morsitans*, the F3 trap (**Figure 3.1g**) has been widely used. From outside, the trap is a blue box, the front lower half of which is folded in to give an entrance with a horizontal shelf above. Other than the rear, all inside surfaces of the upper half of the trap are black, including the shelf. All inside surfaces of the lower half are blue, except for the rear target, which is black. The F2 trap (Flint 1985) is identical in design to the F3, but is white whereas the F3 is blue. The cone is recessed half way into the trap, and is an asymmetric pyramid with its apex to the fore of centre and level with the trap top. Earlier versions used a large wire gauze cage to prevent overcrowding, later replaced by an arrangement of chambers made from plastic bottles and a collecting bag. A blue tarpaulin groundsheet forms the floor of the trap, and this can be greased or sprayed with insecticide to deter ants; the groundsheet is, however, often omitted. The trap is supported internally by a tubular frame, which also provides an external cage support.

NGU trap (Brightwell et al. 1987, 1991)

The NGU trap series (**Figure 3.1h**) were developed primarily to provide an effective, cheap and easily made trap for community-based control of *G. pallidipes*. Three of the series have subsequently been used for both survey and control. From above the NG2G is an equilateral triangle. The rear two sides are blue, the shelf is black and slopes down into the trap from the top. The black target base is attached half way along the base of the two sides and its top is fixed to the upper rear corner. The pyramidal net cone is not recessed and a 12 mm hole in its apex admits flies to the cage. A large polythene cage in the form of a modified tetrahedron is used to avoid overcrowding. The trap and cage are supported externally by poles; the cone is supported internally by a centre pole with three nails in its end. The NG2G has one 1 m blue wing on one side of the entrance, and the NG2F has one 0.5 m blue wing added on each side of the entrance. Both the NG2G and NG2F catch

more *G. pallidipes*, and *Glossina longipennis*, than the original NG2B, but the NG2F version is preferred as it is symmetrical, and hence easier to make and more robust once erected in the field.

Epsilon trap (Hargrove and Langley 1990)

The epsilon trap was developed as an alternative to the F3 and from above, this trap looks like an equilateral triangle (**Figure 3.1i**). Like the F3, it is blue outside, with the lower half of the front folded back into the trap to give a horizontal shelf. The target is a vertical 0.5 × 1 m piece of black cloth sewn into the rear of the trap, all other inside surfaces are blue. As in the F3 the cone is recessed, with its apex level with the top and forward of centre. It uses the same plastic cage design but lacks a groundsheet. It is supported internally by poles held upright by guy ropes.

NZI trap (Mihok 2002)

The NZI trap (**Figure 3.1j**) could be regarded as a variant of the NGU trap, being triangular in cross-section, but having two wings of blue cloth. The trap is efficient for some species of tsetse and has been widely used for sampling biting flies.

H trap (Kappmeier 2000)

The H trap (**Figure 3.1k**) was developed at the Onderstepoort Veterinary Institute, South Africa to catch *Glossina brevipalpis* and *Glossina austeni*. The trap has been used in South Africa, baited with synthetic ox odour (*p*-cresol and 1-octen-3-ol) dispensed from eight sachets with 7 ml mix in each, and acetone (dispensed from a glass bottle with 6 mm hole in top). Unlike sticky panels, flies sampled with the H-trap can be used for release-recapture studies.

S trap (Ndegwa and Mihok 1999)

The S trap (**Figure 3.2**) was recently developed for catching *Glossina swynnertoni* in Tanzania and Kenya. The S1 trap, baited with acetone and octenol, was 3.5 times as effective in catching *G. swynnertoni* than the biconical trap. The trap was less effective in Tanzania. A later modification of this trap, the S3, was 2.9 times as effective as the biconical in Tanzania.

Sticky panel traps (Vreysen et al. 1996, 1998) and water traps

Sticky substances and water traps have been used both to catch flies attracted to coloured screens or trays and to hold flies killed or stunned by other methods such as electric screens.

Sticky panel traps have been used successfully to sample *G. austeni* (Vreysen et al. 1996, Vreysen et al. 1998). Various designs have been developed, including a 3-dimensional white target and a 60 × 70 cm blue or white plywood target that slots into a metal frame which rotates freely in a rod sunk into the ground or a similar trap suspended from a branch (**Figure 3.1l**).

There are various commercially available sticky substances including Tanglefoot®, Stickem®, and Temooacid®. Before any particular type is used for sampling, it is essential to

FIGURE 3.1
Tsetse trap designs currently in use



(a) biconical trap, (b) monoconical (Lancien) trap, (c) pyramidal trap, (d) Vavoua trap (e) monoscreen trap, (f) bipyramidal trap, (g) F3 trap, (h) NGU (NG2G) trap, (i) epsilon trap, (j) NZI trap, (k), H trap, and (l) sticky panel trap (XT)

Note: See FAO training manual for tsetse control personnel, volume 4 (FAO 1992) for further details

FIGURE 3.2
The S3 trap developed for the sampling of *Glossina swynnertoni*



S. MINOX

ensure that the flies cannot pull themselves free. This is best done by just simply watching a sticky trap in operation over a period of time. The sticky substance is normally applied over a coloured metal, wooden or cloth screen up to 1 × 1 m in size.

Sticky metal sheets/trays: a piece of corrugated iron or a plastic tray about 1.2 × 0.6 m is coated with polybutene or other sticky substance (Tanglefoot®, Stickem®, and Temooacid®).

Water trays: a shallow, 4-5 cm deep, tray of the same dimensions as above is filled with water and a little detergent added. The tray is usually painted light brown to match the soil colour; white water trays are themselves attractive to several tsetse species.

Sticky metal trays were widely used initially, but most workers now prefer water trays for stationary electric nets. This is because it is much easier to collect and handle the flies, and they are in better condition for subsequent studies such as counting, dissection for ovarian ageing, etc.

3.1.1.2. Advantages and Disadvantages of Traps

Advantages

- traps can (see below) provide a standardized system of sampling that is not dependent on the varying ability of people to catch flies with hand nets,
- traps can be used for species to which the odour of humans is repellent, e.g. *G. pallidipes* and *G. morsitans*,
- compared to fly rounds, traps catch a higher proportion of females that is more representative of the true sex ratio of the population,
- traps can operate over the full activity period of the fly. If the activity period changes, depending on climatic conditions, methods that only sample for part of the day can give misleading results, and

- traps provide a relatively cheap method of sampling that can be managed by only a few staff (not necessarily the case in large surveys).

Disadvantages

- traps have to be well constructed and maintained to provide a standardized sample,
- as all sampling methods, trap samples are biased towards certain segments of the tsetse population and the details of bias are insufficiently defined to allow correction of the data,
- the efficiency of stationary traps is very dependent on their deployment sites,
- traps are not sensitive enough to readily detect low-density populations of some species, e.g. *G. morsitans*, and
- traps may give a misleading picture of activity patterns because trap efficiency varies through the day, and also because some tsetse species are crepuscular, active at dawn and dusk, and may not be able to see the trap when light intensities are low.

3.1.1.3. Selecting the Most Appropriate Tsetse Trap

Although the basic design of a trap, e.g. a biconical trap, might be the same, there can be variations in that design that can affect its efficiency. Variations seen in the field include the size of the cage, the colour of the blue cloth and the size of the entrance in the blue cloth. Whilst it is preferable to have a design that will be the most efficient, especially when surveying low-density areas, probably the most important thing is that the traps used for a given survey are of the same design and quality. Without such standardization of design the data are less easy to interpret and could be misleading. Similarly, for any given species it is preferable to use the same trap type for the survey. If there are different tsetse species in the area, then the most suitable trap for each species could be selected.

For riverine species such as *G. palpalis* or *G. fuscipes*, use the biconical (designs currently in use, Challier and Laveissière 1973), Vavoua, pyramidal (designs currently in use, Gouteux and Lancien 1986) or bipyramidal (for *G. f. fuscipes*, Gouteux 1991) traps.

For savannah flies, such as *G. morsitans* subspecies and *G. pallidipes*, the best trap seems to depend on where you are. In East Africa, the NG2G (Brightwell et al. 1987) or NZI (Mihok 2002) traps seem to be the best, whereas in southern Africa the epsilon (Hargrove and Langley 1990) is better. However, the ease of deployment and construction should also be taken into consideration when there are only small differences in efficiency between traps. The NZI, F3 and to a lesser extent the NG2G traps are rather cumbersome to deploy, requiring several sticks to be carefully positioned in the ground to support the trap.

For the *fusca* species *G. brevipalpis*, the H trap (Kappmeier 2000) has been found to be the best in South Africa, whereas the NGU and epsilon traps have been used successfully to catch *G. longipennis* in Kenya and Somalia.

3.1.2. Trap Manufacture: Materials and Construction

It is important to have standardized survey traps based on the same design and fabricated from the same materials, and used in conjunction with standardized odour dispensers that dispense attractants at the same, appropriate, pre-determined rates.

TABLE 3.1
Trap types and their suitability for capturing tsetse species.

	Biconical	Pyramidal	Vavoua	Lancien	Epsilon	F3	H-trap	NGU	NZI	Sticky trap	S-trap
<i>Palpalis</i>											
<i>G. p. palpalis</i>	•	•	•								
<i>G. p. gambiensis</i>	•	•	•								
<i>G. tachinoides</i>	•	•	•								
<i>G. fuscipes</i>	•	•	•	•							
<i>Morsitans</i>											
<i>G. morsitans</i>					•						
<i>G. pallidipes</i>	•				•	•		•	•		
<i>G. austeni</i>							•			•	
<i>G. swynnertoni</i>											•
<i>Fusca</i>											
<i>G. longipennis</i>	•				•			•	•		
<i>G. brevipalpis</i>							•			•	

Few *fusca* group tsetse are listed, which is a reflection of the fact that those species, inhabiting forest areas are generally of less economic importance than species of the *palpalis* and *morsitans* subgenera, that are responsible for most transmission of trypanosomosis to humans and livestock, rather than of the fact that traps are not effective against them. Traps will not have been tested against many of the 13 *fusca* subgenus tsetse.

Although traps can often be made locally, using locally available cloth and tailors, this is often not the best option. Batches of cloth and netting material can differ, even from the same supplier, in terms of colour fastness (persistence of the colour) – there can be significant variability in the time taken for colours to fade in the sun. It is therefore preferable that all material comes from the same batch or from a supplier with good quality assurance. As already described, the type of dyes used and the dyeing procedure itself can significantly affect the durability of the trap, especially regarding the colour fastness, that will affect the traps efficiency. Using commercially available traps from a reputable manufacturer, to agreed specifications, is likely to be a cost-effective approach guaranteeing a high degree of standardization of the efficiency of the traps. For community-based surveys or for control operations, there can be advantages to having the traps made in villages within the area as this enhances local involvement and sustainability; this usually leads to a possible decrease in efficiency and standardization.

If traps or targets are to be made in a village or homesteads, there are certain essential rules to be followed. Designs should be as simple as possible; staplers should be considered rather than sewing machines; welding should be avoided as much as possible. Locally available materials such as rush matting, bark cloth or sacking have been proposed for traps, however, they are not recommended for surveys as their durability and the trap efficiency is likely to be variable. Due to the potential difficulty in making traps to a standardized design,

this sort of local manufacture may not be appropriate even if it initially appears to be more economical and to provide the commonly desired involvement of local communities. Locally available items may be used for certain purposes such as making covers to protect odour dispensers from rain or for some odour dispensers such as those for cow urine.

Having selected an appropriate trap design, the most important thing regarding its production is that all traps produced should be of the same standard specifications in all respects especially size, colour (dye) and type of fabric used. Sometimes, different batches of fabric, even though coming from the same manufacturer and factory, may not be consistent in terms of colour and quality of the dyeing. An excellent photographic description, developed by the Natural Resources Institute (NRI), of how to make and site commonly used tsetse fly traps and odour attractant dispensers is available on the internet. Further details of trap design are provided in a World Health Organization (WHO) manual on vector control (WHO 1997). Link: http://www.who.int/docstore/water_sanitation_health/vectorcontrol/.

Most tsetse traps have a netting cone, or inverted funnel shape above the body of the trap. This is designed to allow light to pass and elicit the escape response of tsetse, upwards, towards light, leading them to the holding device or cage. For this reason, the netting should be less visible to tsetse flies. For trap cones, the upward escape response is important, and therefore, the degree of light transmission is critical. Netting colour may have some effect on catches and it has been observed that new “shiny” netting seems to reduce the catch compared to old or dull netting. White or grey netting is usually used for traps cones, or where the cone is recessed, black or grey is more common.

The costs of the different parts of a trap can be reduced by rationalizing the manufacture process, although as stated elsewhere, in order to ensure a higher degree of uniformity and standardization it is recommended that traps are purchased from a commercial supplier.

If the traps are not purchased commercially, all the fabric for traps should be cut out by the team that will use the trap or by a team of tailors supervised by them. When constructing many traps it is best to use templates (e.g. of 8 mm plywood) from which the cloth parts can be accurately marked and cut out. The careful planning of the cloth cutting will minimize wastage and reduce costs.

All the materials used in the construction of the trap must be resistant to weathering and the sort of wear and tear expected in a long-term field survey. Several studies have investigated the possibility of using local plants and plant materials to produce the biconical and other traps: it is unclear whether or not traps made out of natural locally available materials would adequately withstand the effects of a harsh climate for a long time, but equally important it might be more difficult to ensure standardization of such locally manufactured traps.

3.1.2.1. Cloth Fabric

Selection of the appropriate materials for trap construction is a compromise between attractiveness to tsetse, durability, cost and availability. It would seem relatively simple to decide on the most attractive material. However the exact blue is very critical and few workers have access to the facilities required to assess spectral reflectance. When selecting

materials by eye, it is useful to compare it with a sample of material that is known to be attractive, such as phthalogen blue cloth for *morsitans* group flies.

3.1.2.2. Colour and Durability

Experiments done on responses of tsetse to colours in the 1970s and 80s showed that an electric or royal phthalogen blue was most attractive to tsetse; black was just about as attractive as blue but significantly, elicited a much better landing response. The majority of traps have, consequently been designed with a combination of these colours, using blue to attract the flies to the trap and black to encourage the flies to land on it. As the intention is to lead the tsetse flies into the trap and subsequently to catch the flies, the black part of the trap is generally internal, to some extent, so that tsetse flies landing inside the trap will go upwards, funnelled towards the catching device (cage) rather than just flying out in the same direction that they entered. Tsetse flies can detect a wider range of the wavelength spectrum than humans, and are sensitive to wavelengths in the near ultraviolet (UV) part of the spectrum. UV light from fluorescent tubes are often used in appliances for killing tsetse flies in areas where food is produced and consumed; tsetse flies are also attracted to UV light and for *palpalis* group tsetse flies, a high UV reflectivity encourages a landing response. This has been made use of in designing targets to control those species.

When selecting appropriate colours it is important to compare them in daylight, rather than artificial light. Shiny surfaces may reduce the settling response of *morsitans* flies, and this may reduce the effectiveness of synthetic fabrics and plastics.

Blue fabric — Extensive testing of the attractiveness and durability of blue fabric resulted in a mixed polyester cotton (33:67%) (approximately 200 g/m² fabric), dyed in electric blue (phthalogen blue dye for cotton and plasto-soluble blue for polyester) being recommended. Although this fabric is less suitable for impregnation with deltamethrin, its colouring is very stable and it is highly resistant. Equivalent synthetic fabrics (terylene) are more expensive. The blue dye for all types of trap and target should be phthalogen blue. This is highly resistant to fading by sunlight and has the optimum UV reflectance for attracting tsetse.

Black fabric — Black cloth is particularly prone to fading after exposure to sunlight unless it is dyed twice (double dyeing), with acid sulphur dyes. A suitable fabric is a 100% polyamide material (approximately 44 g/m²) dyed with a stable mixture of black and orange (sulphonic sodium acidic salts). The texture of black fabric is less important for the traps; however, it is necessary to choose a fabric with a dye that is resistant to solar radiation. Poor quality material may result from suppliers who dye the cloth just once, with a cheap UV-sensitive dye, or who take cloth originally dyed in another dark colour and dyeing it just once again with black, and then claiming that the double-dyeing requirements are met. In both cases the black will become a light grey – or green – after being exposed to the sun.

Mosquito net — A 100% polyamide mosquito net (approximately 30 g/m²), as above, withstands long exposure to the sun better than 100% polyester netting and is more appropriate for the manufacture of the traps. It is however necessary to change the cones

often (at least once per year, sometimes two). In Côte d'Ivoire, the mosquito netting parts of Vavoua traps were replaced with an opaque white polyamide fabric, which was more resistant and cheaper without significantly reducing their efficiency. The netting must be strong enough to withstand the elements and to give a good base for any sewing to which it is subjected. The "holes" in the netting should be no more than about 4 mm across, i.e., small enough to prevent tsetse flies from squeezing through. For some types of trap, e.g. the epsilon, the netting cone is not visible from outside the trap and so plays no part in visual attraction from a distance. Hence, the colour of the netting is usually not important, provided it allows plenty of light to pass through. For traps such as the biconical and pyramidal, the netting cone is visible from outside the trap and is an important component of visual attractiveness. For such traps the netting is usually recommended to be bright white. However, the netting should not be so opaque as to block more than 50% of through light. The type of fibre for the netting is usually not important and can be cotton or polyester, however, it is important that the netting does not sag under the weight of the trap, deforming its shape. In Zimbabwe, a plastic-coated fibreglass netting has been used satisfactorily.

3.1.2.3. Durability

Materials must be durable under field conditions because an entomological survey can take place over several months and the material must resist handling and bad weather. Fading and other colour changes due to the sun and the rain can be a serious problem; for example white, although highly attractive to *morsitans* species, is now rarely used, as it yellows quickly. Blue dyes vary greatly in their durability, but phthalogen blue on cotton cloth is remarkably colour fast. Blue dyes on pure synthetic materials may rapidly fade to a greyish blue that is much less attractive to tsetse. When selecting materials, the manufacturers should be asked which dyes they use, and how colour-fast they are when exposed to sunlight and rain.

The choice of a suitable type of netting may be difficult. Often, only lightweight cotton net is locally available, and this is easily damaged and rots if exposed to rain; poor quality netting often stretches asymmetrically, deforming the shape of the trap and potentially affecting its efficiency adversely. Nylon netting only lasts a few months if exposed to sunlight, and other more expensive synthetics are preferable.

Summary of optimal fabric requirements for trap construction

- blue: phthalogen electric-blue dyed cotton/polyester mix,
- black: 100% polyamide cloth (44 g/m²) dyed with black and orange sulphonic sodium acidic salts, and
- white mosquito netting: 100% polyamide, approximately 30 g/m².

3.1.2.4. Poles

The poles used for supporting biconical and monoconical traps are usually made out of the sort of metal pipe used for water pipes, cut to about 1.7 m length and with a metal spike, approximately 20 cm long welded to one end. These poles are strong and durable, although heavy to carry for long distances.

3.1.2.5. Cages

One of the most important components of a trap is the cage. The Geigy cage is the most widely used cage design. This rectangular cage measures $10 \times 7 \times 20$ cm, although these dimensions may vary. If the trap cage is too small in relation to the number of flies caught, the flies will be so crowded that they stop light passing down through the cage and into the top of the netting cone. This may reduce the catch by inhibiting the transfer of flies from the trap cone to the cage. Moreover, if there are many flies in the trap they can accumulate at the base, so that they spill over the entrance to the cage, fall to the ground and avoid being recorded in the catches. The cage can be tilted or manufactured as a trapezium rather than a rectangular shape to avoid this. A potential source of error is that the trap efficiency may decrease beyond a certain threshold of flies caught before the cage is emptied. An alternative, in areas where the tsetse density is expected to be high, is to use an arrangement of plastic bottles, shown in **Figure 3.3**, which concentrates live flies away from the cone apex and allows dead ones to fall into a bag for ease of collection.

Another possible solution is to use a larger cage. Large cages have been used in Zimbabwe, especially with F3 traps, however, their size can be inconvenient if many traps are being deployed and only for a short time, especially in areas where the numbers of tsetse expected to be caught are not so high. If the flies are not required for dissection they can be directed away from the cage into a container (a sink), such as a plastic bottle, in which they are killed, either with insecticide or a preservative liquid (formaldehyde solution). For moderate numbers of flies, an internal collecting jar containing preservative can be used to store dead flies away from the cone apex and allows catches to be monitored.

FIGURE 3.3

Photo showing an arrangement of plastic bottles on an epsilon trap that concentrates live flies away from the cone apex and allows dead flies to be collected in a bag

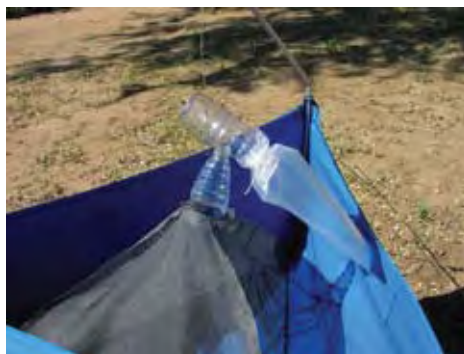

3.1.2.6. Cost and Availability

Maintenance of traps or targets constitutes a major component of total costs. Hence it may be cheaper to use more expensive materials that last a long time and need less maintenance.

In view of the difficulties of importing materials in many instances, local availability is likely to determine the choice of materials. Shortage of a relatively cheap item that has to be imported, or is intermittently available, can seriously disrupt survey programmes. Some imports (e.g. acetone) are in such general use that this may not be a problem, but even locally made supplies may fluctuate in availability. Importation of acetone has become more difficult due to controls imposed to prevent its use for preparation of illegal drugs and due to its flammability. Before existing trap materials are substituted by new ones, their effectiveness should be checked.

3.1.2.7. Alternative Survey Methods for Low-Density Tsetse Populations or Difficult-to-Trap Species

There are a number of additional survey methods that are not in common use, yet may have some merit under certain circumstances, particularly for tsetse species at very low densities or which do not come readily to available standard trap designs.

Odour-baited fly rounds — Hand nets can be used to capture tsetse flies that have been attracted to a man or a bait animal, or to an odour-baited target. One of the earliest ways of sampling tsetse flies was for two or more men to walk along a marked path through the bush stopping at set intervals to collect tsetse flies using hand nets. This is known as a fly round. The technique was used for surveys over very large areas (in Zambia and Zimbabwe) in the past, but has been superseded by traps, especially after it was shown that humans were repellent to *morsitans* group tsetse species. Details of this technique can be found in the FAO training manual for tsetse control personnel, volume 1, section 7.8 (FAO 1982a).

The addition of odours makes this method more sensitive for certain species. A bottle of acetone with a release rate of about 500 mg/h carried at one end of a black cloth screen will increase numbers of *G. m. morsitans*. Traps are not very sensitive for this species. In the past, instead of using bottled odours, an oxen has been led on a fly round and tsetse attracted to its movement and natural odours have been captured in hand nets at intervals along the path of the fly round. This is commonly known as an ox fly round. The technique was used to detect *G. austeni* in an area of low-density infestation at the coast of Kenya (Paling et al. 1987) but is not a widely used technique.

Searching for tsetse pupae — Pupal searches are of limited applicability, but can be useful for detecting tsetse that do not readily come to traps and for low-density populations. Pupal searches have been used to survey tsetse on Unguja Island, Zanzibar (Turner and Makishe 1985) and in Kenya (Paling et al. 1987). The method entails sieving soil samples from likely larviposition sites of tsetse and searching for puparia or empty pupal cases.

Use of artificial refuges — Refuge traps work on the principle that when the ambient temperature rises above 30°C, *morsitans* tsetse flies naturally seek favourable microclimates (Vale 1971). They provide artificially cool dark places to attract resting flies during hot weather. A variety of refuges have been used ranging from complex devices to simple shelters providing shade and lower ambient temperatures. Artificial refuges have so far only been widely used for the savannah species (*G. pallidipes*, *G. morsitans*, and *G. longipennis*) and mostly for research purposes and sampling. They are not recommended for general survey purposes but can be useful for obtaining samples of tsetse for specific types of information and for dissection. They appear to give more representative population samples for the age distribution, and can also be used to collect recently fed flies for blood meal analysis. They cannot be used to give a measure of apparent density because the number of flies entering is directly dependent on the temperature, i.e. tsetse flies only seek refuges above about 32°C and the higher the temperature, the more flies will enter.

Electric nets — Stationary or mobile electric nets supplied with an odour can be used for sampling species that are reluctant to enter traps. Mobile electric traps have been available for at least 30 years but have been little used (stationary electric screens have been very useful for research purposes for evaluating traps, odour attractants and tsetse behaviour and are especially useful for looking at the daily activity patterns of tsetse). Among the main reasons for the fact that electric traps have been little used for survey work is their vulnerability to damage, their high cost and high maintenance requirements. These same factors will likely restrict their future use, except perhaps for specific purposes such as for surveying populations of *G. morsitans* subspecies that do not readily come to stationary traps. Further details are given in the FAO training manual for tsetse control personnel, volume 4 (FAO 1992).

An electric net normally consists of two grids of wires (about 95 x 95 cm) spaced 12 mm apart and separated by a sheet of fine black terylene mosquito netting. Each grid is made up of 0.2 mm diameter copper wires, running parallel and vertical, 8 mm apart. Alternate wires are electrically connected to the top or bottom of the frame via a spring and insulated from the other by a nylon loop. A high voltage is applied between the wires so that any tsetse colliding with the grid is electrocuted and drops down into a collecting device.

Since many flies are only stunned by the nets some form of retaining system is essential. On backpacks, this retaining system consists of a "funnel collector". Stunned or killed tsetse flies fall into a funnel at the base of the screen and slide down the funnel into a collecting bottle.

Stationary electric traps have only been used for research purposes, for which they have been invaluable for gaining an understanding of trap efficiency and behaviour of tsetse towards traps and odours (reviewed in Leak 1998). They are not very useful for survey purposes because of their expense and maintenance requirements and because they do not adequately retain killed or stunned tsetse for counting or dissection.

Mobile electric nets are potentially more useful for survey purposes, although they do suffer from the same constraints of expense and maintenance requirements. Nonetheless, they can be useful tools for trapping species that are not readily caught in other forms of

trap. Two main devices have been used: these are electric backpacks and vehicle mounted electric screens.

Electric back-packs — A portable electric screen is strapped to the back of a man who then walks along a fly round; a modified back-pack has been designed that can be held close to the ground to catch flies approaching below waist level. Electric back-packs have been used to sample *Glossina morsitans submorsitans*, *G. tachinoides*, *G. palpalis*, and *Glossina morsitans centralis*. They have also been used for behaviour studies on *G. m. morsitans* and *G. pallidipes*. The back-pack can be worn all the time, or it can be taken off and held close to the ground at regular stops along the fly round, mainly for *G. palpalis*. Electric back-packs are more efficient for catching flies attracted to man when densities are high, but may be less so at low densities. The female percentage is similar to hand net catches for *G. palpalis* but higher for *G. m. submorsitans*.

Vehicle electric nets — An electric net is fixed at the back of a motorbike or in the back of a pick-up vehicle that is then driven slowly along a sampling transect (**Figure 3.4**). Electrical nets have several advantages and disadvantages.

Advantages

- electrical nets provide a sensitive method of sampling *G. morsitans* when put on a motorbike or a larger vehicle, and
- the efficiency of catching flies by electric nets is less dependent on the number of flies attracted than is catching them by hand nets.

FIGURE 3.4
Vehicle-mounted electric screen for monitoring *Glossina morsitans*



Disadvantages

- electrical nets require a high level of maintenance compared to other sampling methods, and tend to break down frequently under field conditions,
- electrical nets are more expensive than other sampling techniques and impractical for large surveys,
- although their efficiency was formerly thought to be close to 100%, it now seems that the figure is closer to 50% and some flies may actively avoid the nets. To improve the efficiency of electric nets in certain situations it may be advisable to erect a 1-m² black or blue target to enhance the visual stimulus, together with an odour, if appropriate.
- electric nets can only be used when the weather is dry, and
- vehicle-mounted nets can only be operated where access is suitable.

3.1.3. Interpretation of Trap Catches

3.1.3.1. Trap Efficiency

Traps differ in their efficiency even for the same species from one geographical area to another, and therefore, modification of traps is justifiable in order to improve their efficiency. However, this may present complications when comparing traps between one geographical area and another. Unless specifically altered for that purpose, and tested, trap manufacturers should follow the original specifications as closely as possible. If any modifications are made these alterations should be reported, together with test results to avoid inaccurate comparisons being made.

An efficient and attractive trap must stimulate tsetse flies not only to come to the trap but also to enter it. Only 7.5% of *G. palpalis* attracted land on the fabric of a simple blue screen; the addition of two black lateral panels will increase this to 15%. With this same system 82% of the tsetse flies coming directly to the screen land on a blue fabric with high UV reflectivity compared to an ordinary blue fabric for which only 47% do so.

In surveys at cattle ranches in north-eastern Tanzania, catches of *G. pallidipes*, *G. brevipalpis*, *G. m. morsitans* and *G. austeni* were usually about two to three times greater in traps of the NGU, epsilon and F3 types than in the blue biconical and pyramidal traps when used with odours. Catches from moving men were improved about three times when the men carried a black screen, and increased by about another seven times for female *G. pallidipes* when a vehicle was the bait. The sensitivity of surveys for tsetse flies was improved by an estimated 300 times for *G. pallidipes* and two to five times for *G. brevipalpis* and *G. m. morsitans* when surveys use traps instead of vehicles as baits.

3.1.3.2. Attractiveness

The optimal attractiveness and efficiency of a trap will depend upon the judicious choice of a trap site: clear sites, with sufficient sunshine, are optimal, having good visibility providing strong UV reflectivity. The trap must be sufficiently attractive to attract tsetse flies at least from a distance equal to their capacity for perception. Its size must therefore be sufficient (within the bounds of economic feasibility), and it must be constructed with materials for which the attractiveness for the species envisaged has already been tested (these trials can

be easily conducted using electric screens). It cannot always be assumed that a trap that has been tested elsewhere will work as efficiently in another geographical area, or for a species that it has not been tested for. In Côte d'Ivoire, certain blues and white exhibit, for *G. palpalis*, a very high attractiveness proportional to their reflectivity for UV light; in contrast, black has little or no attractiveness.

To sustain a high level of attractiveness over a sufficiently long period it is necessary to use material that is physically durable and chemically stable (see 3.1.2.3.). The attractiveness can be enhanced and maintained by using the trap with a suitable odour attractant if available for the species in question. Features of a good attractant, in addition to stimulating the appropriate response from tsetse, are long-range activity and a sufficiently low volatility so that it does not require constant replenishment (see 3.1.4).

3.1.3.3. Relationship between Trap Catches and Absolute Density

In many situations it would be very useful to know how daily catches compare with the real or absolute population density. If traps are sited in all the vegetation types occupied by the flies, and the trapping intensity is related to the area covered by each vegetation type, i.e. if most of the area is covered by open woodland, most of the traps are in this vegetation type, then there is a good chance that the changes in catches are mainly related to changes in density.

Several studies on *G. pallidipes* in Kenya, *G. pallidipes* and *G. morsitans* in Zimbabwe, and on *G. palpalis* and *Glossina pallicera* in Côte d'Ivoire have shown quite good correlations between trap catches and estimates of population size by mark-release-recapture (FAO 1982a). Such relationships may not, however, be linear. It would be unwise to use these relationships to predict absolute densities in other areas, because they will depend on many factors, especially on the distribution of traps in vegetation types and particularly if the fly distribution is uneven.

3.1.3.4. Sampling Bias with Traps

All methods of sampling tsetse are biased and traps are no exception. Bias can result from (1) flies of certain categories being less active, and therefore less likely to encounter the trap, or (2) flies of certain categories responding differently to the trap once it is encountered.

For a given species, the sample may be biased with respect to sex ratio, physiological age category, pregnancy stage and hunger stage. It is useful to understand and measure the biases of different sampling methods, e.g. low catches in cold weather may be due to the flies being inactive or low trap efficiency rather than a small population. Practically, there is little that can be done regarding the biased samples that might be collected in a survey, but it is important to be aware of them.

Sex ratio — Most traps catch a higher proportion of females than other sampling methods; especially compared to fly rounds that catch predominantly male flies. This does not mean that traps are necessarily unbiased in this respect, only that they are less biased than other sampling methods. In fact, electric screen experiments have shown that most trap designs are more efficient for males than they are for females. The performance of

traps in terms of the segment of the population that they catch can vary with location; in Côte d'Ivoire, it was found from mark-release-recapture experiments that whilst biconical trap catches give an unbiased estimate of the percentage females of *G. palpalis* in villages, they underestimated the percentage females of *G. palpalis* and *G. pallicera* in plantations. Different trap designs vary in their sex-ratio bias. For *G. pallidipes*, NGU and F3 traps catch a higher proportion of females than do biconical traps. The same applies for *G. longipennis*; in biconical trap samples females make up only about 25% of the total compared to 50% in NG2B traps.

Age composition — Very young flies of some tsetse species are generally underrepresented in population samples. This may be because they are less active than older flies. Electric screen experiments have shown that the biconical and NGU trap efficiency for teneneral *G. pallidipes* is the same as for other age categories. For 4–9 day-old flies, the efficiency is actually slightly higher than for older flies.

It has recently been suggested that it is not only very young flies that are less active. With savannah species, activity may increase gradually for the first 40 days of adult life, resulting in undersampling of all the younger age groups. If this is the case, estimates of mortality rates derived from age distributions would be underestimated. Different trap designs may give quite different age compositions. Biconical trap samples of *G. longipennis* usually have a high proportion of 0–9 day old flies — at least 20% — but NG2B trap samples have less than 10% of this category.

Pregnancy stage — The later pregnancy stages are usually underrepresented in trap samples, probably because pregnant females spend more time inactive until very shortly before they larviposit, at which time there is a burst of activity as they respond to the requirement to find larviposition sites.

Hunger stage — Once flies have fed they are inactive for a period of time, and therefore unlikely to be trapped. After this period they become more active and hence more vulnerable to capture; whether this is a sudden or gradual change in the fly behaviour is still not clear. Once they encounter a trap, their entry response may also depend on their hunger stage.

The result of these biases is that samples are composed predominantly of flies in the latter part of the hunger cycle. Much can be learnt about fly populations from looking at the hunger stage using fat-haematin analysis, but there are difficulties in interpretation of such data.

3.1.4. Odour Attractants

Traps on their own are of limited efficiency for catching tsetse and consequently a lot of work was done to identify the substances that attract tsetse to their hosts so that these compounds could be used to increase trap efficiency. These compounds, largely components of host breath, urine and skin secretions are now available for baiting traps and increasing trap efficiency for some tsetse species. They are most effective against *morsitans* group tsetse (although not very effective for *G. m. submorsitans*), but less effective for the

palpalis group. Little work has been done on odour attractants of *fusca* group flies other than *G. brevipalpis* and *G. longipennis*.

3.1.4.1. Available Odour Attractants

Research is still ongoing for effective odour attractants for *palpalis* group tsetse, especially *G. fuscipes*, one of the main hosts of which is the cold-blooded monitor lizard (*Varanus* spp.). The conditions of high humidity and gallery forest habitat (reducing volatility and obstructing odour plumes) may contribute to the lower efficiency of attractants for *palpalis* and *fusca* group tsetse flies. The available odour attractants for tsetse flies were reviewed by Leak (1998), and in a technical document of the FAO/IAEA (IAEA 2003). **Table 3.2** and **Table 3.3**, provide the latest data on odour attractants from East and southern Africa and from West Africa, respectively, reproduced from the IAEA report. Performance of odour attractants for tsetse species against which they have been tested are summarized here in the **Table 3.4** and **Table 3.5**.

TABLE 3.2
Efficiency of odour attractants for tsetse species against which they have been tested.

Species	Odours	Release rate mg/h	Expected increase in catch
<i>G. pallidipes</i>	acetone	150	
	octenol	0.5	
	4-methylphenol	1.5	
	3-n-propylphenol	0.5	
	bovid urine	1000	10–20 ×
<i>G. morsitans</i>	acetone	150	
	octenol	0.5	1.5–7 ×
<i>G. longipalpis</i>	acetone	500	
	3-methylphenol	1	
	4-methylphenol	1	3.4 ×
<i>G. tachinoides</i>	3-methylphenol	1	
	octenol	0.5	1.5–2.5 ×
<i>G. medicorum</i>	3-methylphenol	1	2.8 ×
<i>G. longipennis</i>	acetone	150	
	octenol	0.5	
	4-methylphenol	1.5	
	3-n-propylphenol	0.5	
	bovid urine	1000	5–10 ×
<i>G. brevipalpis</i>	acetone	500	2–3 ×

TABLE 3.3
Efficiency of traps for tsetse species against which they have been tested.

	Species	Trap	Expected increase compared to biconical as standard	
East Africa	<i>G. pallidipes</i>	NG2F/F3/Epsilon	1.4–2.3 × (males)	
Zimbabwe	<i>G. pallidipes</i>	F3/Epsilon	10 ×	
		NG2F	not tested	
	<i>G. morsitans morsitans</i>	F3/Epsilon	4 ×	
Kenya/Tanzania	<i>G. swynnertoni</i>	NG2F/F3/Epsilon	not tested	
		S1 and S3 Trap (acetone + octenol)	2.9–3.5 ×	
	<i>G. longipalpis</i>	Biconical or NG2F/F3/Epsilon	not tested	
	<i>G. austeni</i>	Sticky panel	not tested	
Cote d'Ivoire	<i>G. palpalis</i>	Biconical		
		Pyramidal	2–5 ×	
Congo	<i>G. palpalis</i>	Pyramidal	1 ×	
	<i>G. tachinoides</i>	Biconical		
	<i>G. fuscipes quanzensis</i>	Biconical/Pyramidal	1.6–4.2 ×	
	<i>G. fuscipes fuscipes</i>	Biconical/Pyramidal	1.5– 3.2 ×	
	<i>G. medicorum</i>	Biconical		
	<i>G. longipennis</i>	NG2F/Epsilon/F3		1–2 × males
				3–8 × females
	<i>G. brevipalpis</i>	Biconical		

3.1.4.2. Odour Dispensers and Dispensing Rates

Details of types of odour dispensers, including how to prepare sachets of synthetic odours are given in chapter 2 of the FAO training manual for tsetse control personnel series, volume 4 (FAO 1992).

Cow urine — The more the better for attractiveness. Usually dispensed in 500 ml containers with wide opening protected from rain, e.g. 1-litre plastic washing up liquid bottle with the top cut off. Dispensing rate is variable according to temperature: 500–1500 mg/hour.

Obtaining cow urine — It should be possible to make arrangements with livestock-keepers in the area to collect urine from their cows/oxen usually before being released for grazing in the morning or whilst being milked. Provide farmers with a 20-litre sealable plastic container to store the urine. It has a strong and persistent smell so care is needed not to spill it inside of a vehicle or over other survey equipment. A small payment to farmers might be advisable to ensure their cooperation in maintaining a regular supply. This supply needs to be set-up before the survey operation, not only so that 3-week old urine

TABLE 3.4
Indices of catch increase from odour attractants* in East and southern Africa.

Location	Tsetse species	Odour attractants	Index of increase	Reference	
Zimbabwe	<i>G. m. morsitans</i>	carbon dioxide 2.5–15 l/min	6	Vale 1980	
		acetone 0.3–300 g/l	6	Vale 1980	
		octenol	3	Hall et al. 1984	
	<i>G. pallidipes</i>	carbon dioxide 2.5–15 l/min	6	Hall et al. 1984	
		acetone 0.3–300 g/l	6	Hall et al. 1984	
		acetone, phenol mix	20	Vale and Hall 1985	
		octenol	3	Hall et al. 1984	
Kenya	<i>G. pallidipes</i>	acetone, phenol mix	6-8	Baylis and Nyambiro 1993	
		buffalo urine	9.6	Owaga 1985	
		cow urine	1.8	Owaga 1985	
		octenol + acetone	>7	IAEA 2003	
		POCA	>4		
		POCA + decanal	2.8 – 9		
			POCA + <i>Pinus sylvestris</i> oil	4-5	
			POCA + <i>Pinus pumilionis</i> oil	4-5	
	<i>G. longipennis</i>	acetone and cow urine	4-5	Kyorku et al. 1990	
	<i>G. brevipalpis</i>	POCA + decanal	>4	IAEA 2003	
		POCA + <i>P. sylvestris</i>	>4		
		POCA + isovaleric acid	>11		
<i>G. austeni</i>	octenol + acetone	>2	IAEA 2003		
	POCA	>2			
Tanzania	<i>G. swynnertoni</i>	acetone	~1.7	IAEA 2003	
		POCA	~1.5		
		POCA + decanal	~1.8		
		POCA + octyl formate	~1.6		
	<i>G. pallidipes</i>	POCA + decanal	>4	IAEA 2003	
		POCA + octyl formate	>5		
		POCA + <i>P. sylvestris</i> oil	>4		
		POCA + <i>P. pumilionis</i> oil	>4		
	<i>G. morsitans centralis</i>	acetone	>2		
		POCA	>9	IAEA 2003	
		POCA + octyl formate	>12		
		POCA + decanal	>10		
	<i>G. brevipalpis</i>	<i>P. sylvestris</i> oil	>2		
		POCA + decanal	>6	IAEA 2003	
POCA + <i>P. sylvestris</i> oil		>7			
Uganda	<i>G. fuscipes fuscipes</i>	<i>P. pumilionis</i> oil	>2	IAEA 2003	
Ethiopia	<i>G. pallidipes</i>	cow urine + acetone	2-3		
Somalia	<i>G. pallidipes</i>	acetone, phenol mix	3-4	Torr et al. 1989	
		phenol mix	1.6	Torr et al. 1989	

*Carbon dioxide also exhibits good attractive properties for use with several tsetse species but is rarely used in the field because of the difficulties involved in providing a continuous supply to a number of widely dispersed traps. POCA is an odour blend of propylphenol, octenol, p-cresol and acetone.

TABLE 3.5
Indices of catch increase from odour attractants* in West Africa.

Location	Tsetse species	Odour attractants	Index of increase	Reference
Cote d'Ivoire	<i>G. tachinoides</i>	3:1 4-methyl-phenol + octenol	2.5	Filledier and Mérot 1989
		phenolic fraction of bushbuck urine	1.8	Späth 1997
		monitor lizard skin washings	1.34	Späth 1997
		warthog skin washings	1.46	Späth 1997
	<i>G. longipalpis</i>	warthog urine	1.58	Späth 1997
		domestic pig urine	1.91	Späth 1997
		bushbuck urine	2.51	Späth 1997
		ox urine + acetone	6	Hendrickx et al., unpublished (reported in Hendrickx et al. 1999)
Burkina Faso	<i>G. p. gambiensis</i>	POCA	~1.9	IAEA 2003
	<i>G. tachinoides</i>	POCA	>2	IAEA 2003
		POCA + <i>Pinus sylvestris</i> oil	~1.8	
		POCA + <i>P. sylvestris</i> oil + decyl formate	>2	
		POCA+ <i>P. sylvestris</i> oil (monoconical)	>2	
Mali	<i>G. m. submorsitans</i>	m-cresol + octenol (2:2)	~2	IAEA 2003
		octenol + cow urine	2.5 – 10	
		octenol + cow urine + acetone	2–7	
	<i>G. p. gambiensis</i>	octenol + cow urine	~2	IAEA 2003
		octenol + cow urine + acetone	~2	
		octenol + dodecanal + acetone (monoconical)	~2	
	<i>G. tachinoides</i>	m-cresol + octenol (2:2)	~2	IAEA 2003
		octenol + cow urine	~2	
		octenol + cow urine + acetone	~2	
		m-cresol + octenol + acetone	~7	
		<i>P. sylvestris</i> oil	~4	

* Different trapping systems and rates of dispensing odours were used to obtain these indices of increase, thus, the figures provide only a rough guide. Details of experimental methods are given in the references. POCA is an odour blend of propylphenol, octenol, p-cresol and acetone.

is available (bacteria convert chemicals in the urine to phenolic compounds over time) but also to ensure that the system will work in supplying the necessary quantity as required. The cow urine can be used for a long time (months), especially if it is occasionally topped up as required.

TABLE 3.6
Summary of available odour attractants and their usefulness for trapping different species of tsetse flies.

Species	Acetone	Octenol	4-methyl phenol	3-n-propyl phenol	3-methyl phenol
<i>G. pallidipes</i>	Yes	Yes	Yes	Yes	No
<i>G. morsitans morsitans</i>	Yes	Yes	No	No	No
<i>G. morsitans centralis</i>	Yes	Yes	No	No	No
<i>G. morsitans submorsitans</i>	Yes	Yes	No	No	No
<i>G. longipennis</i>	Yes	Yes	Yes	No	No
<i>G. austeni</i>	No	No	No	No	No
<i>G. brevipalpis</i>	Yes	Yes	Yes	No	No
<i>G. tachinoides</i>	No	Yes	No	No	Yes
<i>G. fuscipes</i>	No	No	No	No	No

Adapted from Natural Resources Institute.

Acetone — Acetone is more volatile so a smaller opening to the container is used, e.g. a 16 mm aperture in a glass or suitable (polyethylene) plastic bottle (note that acetone dissolves some types of plastic!). Dispensing rate will be 500-800 mg/hour depending on ambient temperature, wind and aperture.

Synthetic phenols — These chemicals are often supplied in sachets, although they can also be mixed and put in sachets by the project staff. The size of the sachets is small, usually only about 2 ml. The dispensing rate will depend upon the thickness of the wall of the sachet; it is usually about 0.5 mg/hour for octenol, 1.0–1.5 mg/h for 4-methylphenol, and 0.5 mg/h for 3-n-propylphenol. Note that octenol is repellent at high concentrations.

3.1.5. Deployment of Traps

Trap efficiency can vary according to the tsetse species targeted, season, geographical area and the way that the trap is manufactured, maintained and deployed. An odour-baited epsilon trap may catch only 1–2% of the *G. pallidipes* population in the square kilometre surrounding the trap each day — thus for every fly that we catch there are roughly 100 flies that are not captured. Possibilities for such variability could obviously lead to misleading results. For that reason it is important to:

- standardize the deployment of traps,
- use sufficient number of traps to allow pooled density estimates to be more representative, and
- deploy the trap for a sufficient number of days at each site.

Even for the most efficient traps, about half the tsetse flies that approach a trap, do not enter (Vale and Hargrove 1979). An old, poorly sited trap, that is faded and has holes

in the netting will obviously be much less efficient and may not be very useful in providing the information required from a survey (Green and Flint 1986, Vale 1998).

3.1.5.1. How to Deploy a Trap

Having selected the most appropriate trap for a survey, the deployment of that trap can also significantly affect its efficiency. Trap catches have a degree of variability due to many factors, some of which are known, particularly environmental factors, and some of which remain unclear. It is important to maximize the traps efficiency as much as possible, especially when trying to detect flies in areas of very low density, such as at the limits of their distribution. The site of a trap used for a survey will not be the same as for tsetse control using traps. As the purpose of using traps in a survey, in addition to determining abundance in a given area, is to determine absence and presence and to identify the habitats used at different times of year, traps need to be sited in places where the habitat is not optimal and consequently expected density will be low to absent. For control purposes traps would be sited predominantly in areas of optimal habitat where the largest number of flies can be quickly killed.

The following factors should be taken into consideration when deploying a trap:

1. Height of the trap above ground level — Different tsetse species fly and feed at different heights above ground level and the height of a trap will affect its efficiency. Most tsetse species fly fairly low, but for many species no studies have been carried out. *G. austeni*, *G. tachinoides* and *G. pallidipes* are among the species known to feed at low heights above ground level and may be more readily caught in traps whose entrance is closer to the ground. More is known regarding the economically important species of the *palpalis* and *morsitans* subgenera for which studies have been conducted in relation to control using traps, targets and insecticide-treated cattle. Studies carried out for the purpose of increasing efficiency and reducing costs, showed that the majority of *palpalis* group tsetse land on the lower half of a cloth target; therefore, in suppression programmes based on insecticide-treated targets, savings could be made by just applying the insecticide to the lower half. Similarly, the majority of *G. pallidipes* feed on the lower legs of livestock; thus in programmes that are using insecticide pour-ons on livestock, savings can be made by treating only the legs with insecticide. The height of a biconical trap for catching *G. palpalis* should be approximately 45 cm from the ground as shown in **Figure 3.1a**. Of course in many situations there is more than one species of tsetse (*G. palpalis* often occurs in West Africa with *G. tachinoides*) so the height of the trap may have to be a compromise depending on the behaviour of each species. The most important thing is that the height is appropriate and is standardized for all traps.

2. Light — Tsetse flies exhibit a preference for resting in shaded places with sufficiently high relative humidity and cooler temperatures, which protects the flies from desiccation. As such, traps are more efficient when sited close to such shaded areas but in sunlight where visibility is greater and there is a greater degree of reflectance of UV light from the blue cloth of the trap. Very open areas of grassland (pasture) or grassed wetlands should be avoided. Tsetse flies caught in traps in open places and exposed to the full sunlight, will

more quickly become desiccated and die. Therefore, if flies are needed alive for dissection, traps should either be visited for collection at shorter intervals (2-hourly) or placed in locations with some shade.

3. Wind direction and trap entrance orientation — A lot of work has been carried out on the way how tsetse detect and approach a trap, particularly in relation to odours and the behaviour of odours in wind (summarized in Leak 1998). Tsetse detecting an odour source whilst resting will take off and fly upwind. Depending on wind speed and characteristics of the vegetation, odour plumes may break up and become disrupted and tsetse have evolved behavioural adaptations helping them to redetect lost odour plumes. Tsetse will therefore tend to fly upwind, following an odour plume to an odour-baited trap. The trap entrance should therefore be orientated appropriately, i.e. facing downwind so that approaching tsetse will be led straight to the trap entrance.

4. Protection from predators and prevention of trap losses — The captured flies must be protected from predation by ants and other insects as much as possible. Even though signs of ant damage, severed wings, legs, etc., are not visible, there may still be a problem. Some species of ants may remove the whole fly from the cage. The best protection is to coat all trap supports with car grease, which has no reported effect on trap catches, or, if safari ants are present, Stickem®. The disadvantage of this is that for traps that are being re-deployed every 3–4 days, the grease can be an inconvenience unless it is adequately cleaned off the poles each time the trap is removed. If the flies are not required alive a collecting bottle with a preservative can be used. Frogs and other creatures have been known to get into trap cages occasionally.

Immediately prior to trap deployment, a workshop should be organized for the trap assistants and other persons involved in trap deployment in order to refresh their knowledge from previous training courses, regarding all aspects of trap deployment, with special emphasis on standardization of procedures.

Checklist for equipment needed when deploying traps — At the beginning of the survey it is quite possible that some items that are required in the field are overlooked. Think what is going to be done in advance, step by step, and prepare a checklist of the items required. These items can be prepared and ticked off before leaving for the field. For example, (1) in addition to the traps and cages, something will be needed to hammer the poles into the ground (in the dry season some areas of ground are very hard or rocky). People often use nearby rocks but a good strong steel mallet is preferable — one will be needed for each team, (2) grease (or Stickem®) for protecting the trap catches from ants, (3) paper and pens for recording information, and for labelling trap cages, (4) recording sheets and a clip board for supporting the sheets — don't go to the field without these and end up writing information on scraps of paper that can get lost, (5) batteries for GPS instruments and rubber bands (of a suitable size) for holding cages onto the traps and avoiding gaps between the cage netting and the trap netting through which tsetse can escape are likewise needed.

3.1.5.2. Where to Deploy Traps — Selection and Characteristics of Suitable Sites

Together with survey team members, each survey team will study the maps, satellite images, and vegetation/land use maps and identify areas for trap deployment. Criteria to be taken into account are:

1. Areas of suitable habitat — Identify areas of suitable habitat (riverine forest, thicket, savannah woodland, forest) and allocate trap deployment sites according to the proportion of each habitat within the grid square, weighted towards the favoured habitat of the target tsetse species.

2. Accessibility — In addition to the above criterion, select sites that have suitable access – even if it is desirable, it will not always be practical to deploy traps in locations that will take an hour or more to reach on foot. A compromise has to be made between what would be desirable in theory and what is achievable practically, given the time and human resources available. This does not mean, however, that all traps should be sited right next to a road where the habitat might be quite unfavourable and the trap subject to interference.

3. Location within the survey zone — As mentioned previously, one of the principal objectives will be to determine the limits of the tsetse distribution. In the middle of the infested zone, where there might be a large expanse of suitable habitat, a few traps will be sufficient to determine the mean apparent density. In contrast, on the borders of the area, and particularly where there might be a narrow tsetse-free corridor between two distinct areas of infestation, it will be important to determine the precise seasonal limits, and consequently a larger number of traps should be deployed in such areas (bear in mind that catching a tsetse proves their presence, but not catching tsetse does not prove their absence).

Having identified locations on the map, when deploying the trap it will be necessary to verify the true suitability of the site in the field and some modification might have to be made accordingly. The position in which a trap is sited will vary according to the purpose (a survey, ecological study or for tsetse suppression) (see 3.1.5.1.). Whatever the site, the vegetation should be cleared within a set radius (3–4 m) around the trap. This helps to standardize visibility of the trap and will minimize the possibility of damage by fire. Each trap position should be marked, numbered and georeferenced.

3.1.5.3. Habitat Characteristics

Species of the three tsetse subgenera have different ecological niches, requiring different approaches to their sampling and the design of a survey scheme. A variety of traps have been developed, each one usually targeting a particular species or group of species. These traps do not work with the same degree of efficiency against other species and even against the same species. Variations in efficiency have also been found from one country to another.

Savannah habitats

Select an area of tsetse habitat, such as woodland or thicket, and avoid open areas such as fields and open, low-lying grasslands (called vleis, or dambos in southern Africa), and within the habitat, select an open site, ideally with paths or linear openings leading to the site that will make the trap clearly visible from a distance.

The specific point where the trap is erected should have:

- no leafy canopy overhead, especially if this might shade the trap when tsetse are active in the early morning or late afternoon,
- no leafy bushes or obstructions, such as termite hills or dense bushes, within 3 m of the trap, and
- no fallen tree boles within 15 m of the trap. Why? Because that site may be chosen in preference to the trap as it offers a typical larviposition site for females, or resting site for recently fed flies.

The trap must be assembled correctly as small errors can greatly reduce the efficiency of a trap. For instance, a small gap between the top cage and the netting cone of an epsilon trap will allow flies to escape.

Sometimes grease or other sticky material is put around the supporting poles of the trap, or even on the lower cloth components, as a barrier to ant invasion. However, this is messy, and before long the grease can get on other parts of the trap. Moreover, the grease can rapidly become covered in dust, so that ants can walk over it. Often wind-blown leaves lodge at the trap's base, forming ladders to by-pass the sticky deposit. More info and slide shows on how to assemble traps can be found on <http://www.tsetse.org/>

Vale (1998) listed the following rules for optimal siting of traps:

- choose level ground on which the trap can be most easily erected, but if such ground is not available, gentle slopes will do,
- avoid shade from dense canopies overhead, or from nearby trees that obscure the afternoon sun,
- keep 5 m clear of large obstructions such as dense leafy bushes, fallen trees, tall grass and large anthills. Be sure that there are paths at least 1 m wide radiating from the site, especially in a downwind direction. The downwind path should connect with other paths in various directions, and
- if, in a few minutes search you do not find a site that is naturally unshaded and unobstructed, choose the site where minor trimming of vegetation will allow you to create the desired site as nearly as possible. Then clear the grass and herbs within 3 m of the trap or within 5 m if there is a risk of bush fire. Traps should be deployed with its entrance facing down the prevailing wind. Keep the site clear and trim on return visits.

Free standing or hung from a branch — For some traps (e.g. the biconical, moniconical and pyramidal), one means of reducing costs may be to hang them from trees rather than their being “free standing”. Apart from reduced cost, this has the added advantage that they cannot be easily knocked over, although they may still be affected by strong wind.

However, there is not always a convenient tree branch available, and some traps due to their design (NGU, F3 and epsilon) must have supports, either internally using a frame or externally by means of poles or guy ropes. External supports are usually cheaper, and have the advantage that guy ropes can be adjusted when the cloth stretches.

Forest and riverine habitats

In riverine habitats of *palpalis* subgenus tsetse, traps should be deployed along the length of gallery forests:

- every 300 m (the interval of 300 m does not have to be precise),
- close to the banks,
- in open and sunny places (they can be in a range of up to about 10 m from the 300 m mark),
- at closer intervals in places frequented by people (one every 100 m or less),
- bathing places or washing places,
- bridges and fords,
- sites for mooring/landing pirogues and mending of fishing nets,
- all other places of human activity, and
- orchards — irrigated citrus or mango orchards may be good habitats for *palpalis* group tsetse as in the Niayes area of Senegal close to Dakar.

The deployment of traps may be done on foot, following the banks for the surroundings of a village and by pirogue for sites further off. This method is easy, rapid and allows one to cross from one bank to the other to choose the best site. In West Africa (e.g. Côte d'Ivoire), small motorbikes are often used for the deployment of traps, these being easy to use around villages linked by paths and small tracks rather than roads along which vehicles can pass.

When trapping riverine tsetse species — although it will generally be preferable to deploy traps on fixed poles — there may be occasions when traps will be suspended from trees over wet places. The movement of suspended traps in the wind may enhance their efficiency as tsetse may be attracted by the moving object however, unless deployed carefully, there could also be a danger of the trap swinging into branches, stopping it from functioning. On the other hand, in high-risk sites such as certain bathing places, there may be few or no trees from which the traps could be suspended, and in such cases it is necessary to use a pole.

Traps in mangrove swamps must be placed in all the potentially dangerous contact sites between tsetse and humans. The deployment is complicated by tidal marshes that present the risk of traps being submerged and if they are placed away from those areas they will not function well.

The following places are recommended for trap sites:

- at the edges of villages and near to camps if they exist; deployed with conventional supports (poles),
- near water points,
- at points of disembarkation,

- landing points of pirogues where the steepness means that the distance between low and high tide marks is not great, and
- on firm ground near all workplaces or collection places such as places for collection prawns.

In places where there are channels frequently used by fishermen or at places used by people for boarding or loading boats, floating traps can be deployed. Floating traps have been used successfully for small-scale tsetse surveys in sleeping sickness foci close to Conakry, Guinea. The flotation units must be fixed to avoid them being carried away or moved by the tides or currents. The sites chosen should preferably be flat so that the trap remains upright in shallow water.

Some towns and even capitals have sites for tsetse flies on the edges or even in the centres, for example, Stanley Pool near Kinshasa is a known tsetse habitat and tsetse are found in the centre of Dakar, in the zoological gardens.

Traps can be deployed:

- along water courses,
- near to all water collection points,
- along the edges (ecotones) of orchards (e.g. forest gardens), and
- near to enclosures of animals (e.g. zoos, livestock units, etc.).

It is essential to verify certain epidemiological factors in the field by visiting or questioning, in order to identify all the other potential habitats for tsetse, e.g. sacred forests, mango plantations, citrus orchards, etc.

When carrying out surveys in respect of human sleeping sickness, it can be useful to administer questionnaires addressing the activities and behaviour of the people in order to get a better understanding of the potential areas where transmission is taking place; this transmission is quite likely to be outside the villages at places where people conduct their other activities. These activities may even take place on different river systems at some distance from the village.

The identification of the origins (homes) of sick people may only give an approximation of the limits of the endemic zone, as it does not take into account the distances that the people may have travelled to become exposed to the disease. This should be taken into account by including the locations of activity sites when designing epidemiological questionnaire surveys.

Surveys in some savannah areas and surveys along the banks of rivers for *palpalis* group tsetse, particularly in West Africa, can be subject to the very specific problem of seasonal flooding. At the beginning of the rainy season water levels can rise very quickly, submerging and carrying away traps. Seasonal flooding is usually part of local knowledge that has to be taken into account during planning.

Surveying in fragmented habitats such as occur in many areas of West Africa where human population growth and associated activities have altered the vegetation can become more complicated. An example is the Niayes area of Senegal. The Niayes refers to areas of natural vegetation (oil palms, etc.) in low-lying coastal areas that have traditionally been infested by tsetse. Human activities have fragmented many of these areas, some of

which are quite small and frequently used for horticultural activities because of the possibility of obtaining water from wells in the depressions. Surveying thus becomes more complex in peri-urban areas with this type of habitat; there is no clear “edge” of the distribution and the probability of missing an area of suitable habitat is higher. In such a situation high resolution, recent vegetation maps and satellite images will be very useful.

3.1.5.4. Trapping *morsitans* Group (Savannah Habitat) Tsetse Species

Glossina pallidipes — This species enters traps readily, and was the first species to be controlled by trapping (using the Harris trap in the 1920s). The biconical trap has been used widely in the past in East Africa to sample this species. It is adequate for ecological work when fly densities are fairly high, but more sensitive traps have now been developed. The most commonly used being the F3, those of the NGU series and the epsilon.

In south-western Kenya, the F3 and the winged NGU's (NG2F and NG2G) perform similarly, catching about twice as many males and 3–5 times as many females as the biconical. The epsilon catches fewer flies than the NG2G, although it is still better than the biconical. On the Kenya coast the NG2G and epsilon catch about 1.4 times more males and twice as many females as the biconical, with the F3 catching similar numbers of males and about 1.5 times more females than the biconical. In Somalia the F3 is about 2–3 times better than the biconical, whilst in Ethiopia the NG2B is about 2–3 times better than the biconical.

In Zimbabwe, the F3 catches 10 times more *G. pallidipes* than the biconical. Unlike in East Africa, the F3 is about twice as effective as the NG2B; the epsilon catches similar numbers to the F3 trap.

For survey and monitoring of *G. pallidipes*, either the NG2G, F3 or epsilon traps are recommended.

***Glossina morsitans* subspecies** — Traps are generally less efficient for catching the *G. morsitans* subspecies than they are for *G. pallidipes*. For monitoring low-density populations, sampling with mobile electric nets or odour-baited fly rounds has been recommended although neither method has been widely practiced (in view of their cumbersome nature), especially for surveys of large areas. The biconical, the F2 or F3, the epsilon and the NG2G traps have all been used in recent years for sampling.

Again, the newer traps are more effective than the biconical for *G. m morsitans*, although the difference is not as significant as it is with *G. pallidipes*. In Zimbabwe, the F3 is about four times as effective as the biconical. For *G. m. submorsitans* in The Gambia, no significant difference was observed between catches in F2 and biconical traps.

F3, epsilon or NG2F traps are recommended for survey and monitoring of *G. morsitans*, although more testing is needed for the various subspecies.

G. austeni is very reluctant to enter traps, although high catches have sometimes been recorded in biconical traps. The pyramidal may also be effective for this species. The newly developed H trap and the sticky two- and three- dimensional panel traps were more effective and are recommended for this species.

The biconical trap can also be used to sample *G. longipalpis* and *G. swynnertoni*.

3.1.5.5. *Trapping palpalis Group (Riverine Habitat) Tsetse Species*

Glossina palpalis — The biconical, pyramidal and Vavoua trap are recommended for these species.

Glossina fuscipes — The most frequently used traps for sampling *G. fuscipes* are the biconical, bipyramidal and the pyramidal. For *G. f. quanzensis*, the pyramidal is 1.6–4.2 times more effective than the biconical. For *G. f. fuscipes* in Kenya and Uganda, results are conflicting, with the pyramidal sometimes more effective than the biconical and sometimes *vice versa*.

Early trials in Uganda suggest that the monoscreen trap may catch more *G. f. fuscipes* than the pyramidal, but it is less effective than either the biconical or pyramidal in Kenya. The F3 and the NG2B and NG2G are certainly less effective than either the pyramidal or biconical traps.

Either the pyramidal or the biconical (unbaited) are recommended for monitoring, with either of these or the cheaper monoscreen trap being effective for control.

Little comparative work has been done to compare trap types for *Glossina caliginea* and *G. pallicera*. Mark-release-recapture and trapping studies on *G. pallicera* in Côte d'Ivoire have shown that the biconical is an effective sampling tool for this species, and is about as sensitive as it is for *G. palpalis*.

3.1.5.6. *Trapping fusca Group (Forest Habitat) Tsetse Species*

Glossina longipennis — The biconical, F3, NGU series and the epsilon trap have all been used to trap *G. longipennis*. In south-western Kenya, the F3 and the NG2G traps are considerably more effective than the biconical, especially when the F3 is used without the blue floor, being significantly more effective at catching females than males. On the Kenya coast, the NG2G, the epsilon and the F3 traps all caught about twice as many males, but only about 2-3 times as many females as the biconical.

Various traps have been tested for *G. brevipalpis*, including the biconical, NG2B and NG2G. The biconical and the H trap are probably the best traps, although the H trap is much more cumbersome to deploy than the biconical trap. In Tanzania, comparisons were made between the H trap and the biconical, but trap catches were too low to draw meaningful conclusions (IAEA 2003).

The biconical will also catch a number of other species such as *Glossina medicorum*, *Glossina tabaniformis*, *Glossina nashi* and *Glossina nigrofusca*. Numbers are usually small, but normally it is not known if this reflects a low efficiency of the trap or low densities. The biconical is, however, known to be less sensitive for *G. nigrofusca* than it is for *G. palpalis*.

3.1.5.7. *Collection Procedures*

Once a survey trap has been sited in a georeferenced position, that position should during subsequent survey occasions, not be changed under normal circumstances. Any site change of even a few metres can alter the catch significantly (site effect).

On reaching a trap:

- check its condition to ensure that it has been functioning properly,
- record the time of collection on the data-recording sheet,
- check for flies that are still in the body of the trap and if there are any, either chase them into the trap cage or catch them manually,
- remove the cage, being careful not to allow any flies to escape or dead flies to fall to the ground. Add any manually caught tsetse to the cage, being careful not to allow any flies to fall or escape,
- attach a label to the cage (or put it inside) giving the unique trap identification number and date, and
- carefully place the cage in a cold box, or other box for transportation, that will protect the cage from damage and help preserve flies alive for dissection.

If further trapping is going to take place:

- fix a replacement cage to the trap, ensuring that it has no holes in it through which tsetse could escape,
- put a rubber band around the base of the cage making a tight fit between the extended cage netting and the netting of the body of the trap,
- verify that the odour attractant dispensers (if any) are upright and have a sufficient quantity of attractant,
- top-up attractants if necessary and check protectors from rain are in place,
- check, and repair if necessary, protection from ants (e.g. grease on trap pole), and
- record time of resetting the trap and details of attractant replenishment on recording form.

If no further trapping is going to take place:

- remove the cloth parts of the trap and pack carefully to avoid damage during transportation,
- remove grease from the trap pole and pack carefully to avoid damage during transportation,
- either throw away cow urine or return to large container if still usable — pack container in a sample box, and
- collect and store other odour attractants and dispensers safely to avoid spillage (especially of acetone which dissolves paint and can cause some damage).

Time schedule for deployment and collection — To take into account the different activity peaks of tsetse, that differ between species and between seasons it is preferable to have a fixed schedule for inspection of traps for collection of trapped flies. If this is not done it is possible for collections to be made in a way that could provide misleading results by missing activity peaks at the time of deployment and trap inspection. For this reason, the time of trap deployment (setting) and collection (harvesting) are recorded on the appropriate sheets (**Table 2.6**). Tsetse should be collected from the traps at the same time each day, preferably at a time when tsetse flies are inactive, e.g. very early morning. Thus it is important to maintain a sequence of trap deployment and “harvesting”.

Any damage to the trap or odour dispensers should be recorded, and a needle and thread, or stapler, should always be carried to repair any minor damage. Cages must be checked for holes before deployment every day before putting them on the trap, and odours replenished when necessary.

The base of the lower cone of a biconical trap, and the shelf of an F3 trap, should be checked for any dead flies that may have dropped down. These should be put into the cage for counting. If there are live flies in the cone that have not yet entered the cage, they can be caught and included in that days catch or left to enter the cage to be counted the next day. Most mosquito net cones or pyramids are very worn out after about six months and it is necessary to replace them although the rest of the trap can be re-used.

Collecting flies 2–3 times per day is sometimes advisable for samples required for dissection in order to avoid high mortality and high abortion rates in cages.

Labelling of trap cages — The labels for trap cages should be made of something durable, as scraps of paper can easily become illegible or get lost. Card, or plastic labels, e.g. 2 cm squares of plastic cut from an empty five-litre (for example, cooking oil or engine oil) container with trap numbers written on them in indelible ink are suitable alternatives (suitability depends on the numbering/labelling system used for traps). A label giving trap position should be put inside the cage, and the cages kept in a box, preferably covered with a wet black cloth to keep the flies quiet, especially if they are to be dissected later.

The trap assistant records the date of collection, the number of tsetse captured by each trap, trap identification and the type of site where each trap is situated.

3.1.5.8. Using a Data Logger GPS to Enter Trap Details

When locating traps with a data logger GPS, the data relevant to each trap can be brought up on the GPS screen for the selected trap. The GPS will direct you to the location (**Figure 3.5**).

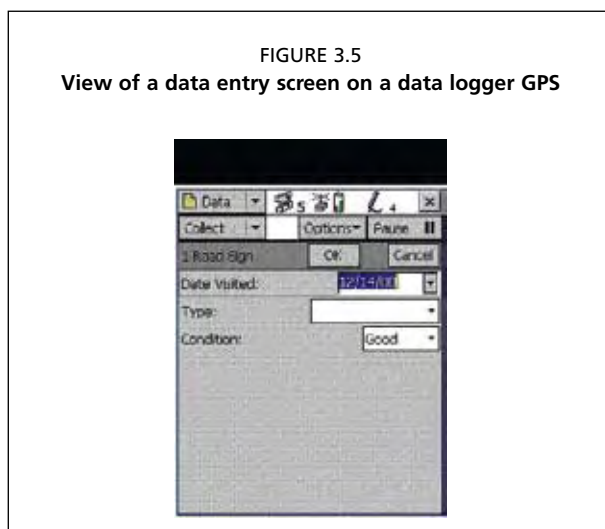

The software application that accompanies a data logger GPS will allow us to define a list of attributes for each feature to be collected. For example, for each tsetse trap we will want to record the trap identification number, the type of trap, the surroundings, the date the trap is placed. The trap ID will most likely be a numeric field, but the trap type as well as the surroundings should be chosen from a drop-down list. Creating a “data dictionary” on the PC using the software package that interfaces with the GPS allows us to define each attribute as we chose, then to upload this data dictionary to the GPS. The resulting data collection screen on the GPS reflects the type of attributes we defined in the data dictionary. Collecting trap details in this manner avoids error and saves time.

3.1.6. Maintaining the Survey Equipment

3.1.6.1. Traps

There are many factors affecting the number of flies caught over which we have no control, e.g. climate, movements of wild or domestic animals, etc. This means care has to be taken to minimize the sources of variability — such as ensuring the good condition of the traps, especially repairing holes in cages — over which one does have control.

Keeping traps in good functioning condition is vital because traps with holes in the netting, faded or otherwise in poor condition will not function properly and are almost useless for determining presence of tsetse in low densities. It is therefore important to store them well, and to carry out continuous routine maintenance; unfortunately this is often not carried out during survey operations. The reasons are sometimes understandable: traps may be in constant use with survey personnel often coming back from the field late, having worked under difficult conditions. With sufficient planning and adequate funding these difficulties can be overcome. A large amount of damage done to traps comes about during their transportation to and from the field. Traps and cages tend to be thrown in the back of a pick-up or similar vehicle after collection or before being deployed and netting is rapidly damaged from bouncing around in a vehicle on rough roads or from poles tearing holes in netting fabric. Consequently, it is common for old cages with holes to be used resulting in data gathered from trap samples that is of little value. If a hole is found in a cage the trap should be recorded as non-functional. Much of this damage could be avoided with more care in packing the traps in the vehicle and using suitable boxes for packing. Nonetheless, with field personnel working long hours under difficult conditions in the field, it is inevitable that damage will occur.

A number of traps in excess of requirements should be kept so that damaged traps can be withdrawn and replaced with others whilst they are being repaired.

Somebody who does not go out to the field on surveys should be responsible for their storage and maintenance. Traps should be stored carefully in a dry place with no possibility of damage by rats, mice or termites. Cages, cones, poles and fabric components should be stored separately where possible.

Traps and cages should be carefully checked before being deployed and holes should be mended with a needle and thread, paying particular attention to the netting. If damage is minor, this can be done in the field as traps are deployed, although it is preferable that they are checked and repaired at the field station store.

It is desirable to have an additional routine scheduled check of traps every month. The use of check-lists that have to be ticked off, signed and handed to a supervisor is useful; otherwise routine activities that are supposed to be done but are not otherwise planned are often eventually forgotten or neglected.

3.1.6.2. Vehicles

It is rare that there will be spare vehicles available for use if one of the vehicles used for a survey is off the road for some reason, although of course it would be desirable to have such a spare vehicle so that routine maintenance and repairs that will be necessary from time to time can be carried out without disrupting a survey. As that is unlikely to be the case, it is important to do whatever possible to prevent vehicles from being out of service. This can be achieved by regular servicing and replacement of worn parts before they have caused a problem and by keeping a stock of frequently used parts (oil and fuel filters, tyres, brake pads, etc.). Keeping such a stock of parts may not always be easy within government administrative and procedural structures. Routine checking of vehicles (see check-list in **Table 3.7**) will also identify arising problems so that they can be dealt with swiftly.

3.1.6.3. GPS Instruments

Some early models of GPS instruments used up batteries rapidly. Although the rate of battery consumption is now greatly improved, a stock of batteries will be required and field teams should be equipped with spare sets of batteries. These batteries should be of a good quality, which are frequently not found in rural areas. Most GPS come with a carrying case that should be used to avoid the glass display panel from becoming scratched or otherwise damaged.

TABLE 3.7
Example of a monthly check-list.

Date:		Checked by:		
	<i>Number checked</i>	<i>Good condition</i>	<i>Needing repair</i>	<i>Initials</i>
Traps				
Cages				
Odour attractant dispensers				
<i>Vehicles</i>	<i>Kilometres</i>	<i>Condition</i>	<i>Items needing repair</i>	<i>Next service due</i>
Vehicle 1 (reg)				
Vehicle 2 (reg)				
Vehicle 3 (reg)				
Vehicle 4 (reg)				
Signature of Supervisor:		Date:		

3.2. ENTOMOLOGICAL PROCEDURES

In addition to the basic required information such as the identity of the tsetse species present in an area, their sex and apparent density, there are additional parameters, knowledge of which will contribute to the development of control/eradication planning and monitoring. Among these additional parameters are:

- the trypanosome infection rates in tsetse and trypanosome species identity,
- the age structure of the tsetse population,
- their feeding habits (hosts),
- mortality rates,
- nutritional status,
- genetic structure of the tsetse population.

Unless many staff is available for the main, surveying activity of the project, it may not be possible for the survey teams, responsible for deploying traps and harvesting tsetse from them, to also carry out the additional entomological data collection. It will not be practical for tsetse brought back to the laboratory at the end of a day of collection to be dissected by the same people at the end of that day. Furthermore, many tsetse flies captured will be dead by the time they reach the laboratory and will be unsuitable for dissection. For those practical reasons, it is preferable to have an additional team who will be responsible for collection of the additional data. Traps for those data may be fewer in number than those used for the basic survey so that they can be visited, and the flies collected at more frequent intervals so that they are still alive and fresh for dissection. The distribution of those traps may be based on different criteria from those of survey traps according to what information is needed in the area.

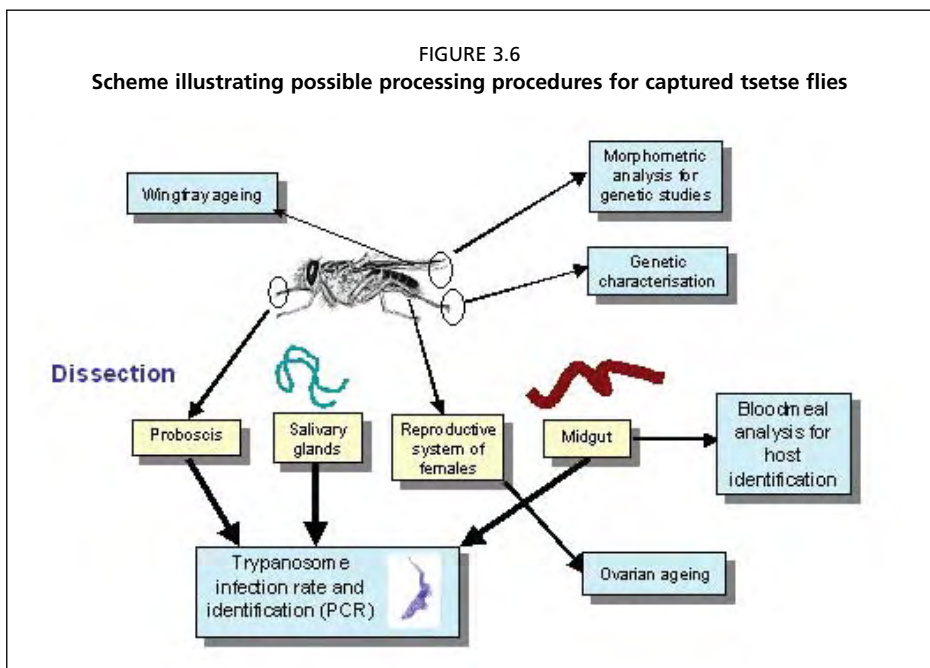

3.2.1. Identification of Tsetse Species and Sex

Tsetse species can be identified using conventional identification keys of the sort that are available in standard texts (e.g. Machado 1954, 1959 (for *palpalis* group tsetse), Buxton 1955, Mulligan 1970, FAO 1982a, section 1, these guidelines) or by using interactive computer-based identification programmes such as the computer identification package developed by L'Institut de Recherche pour le Développement (IRD)/Centre de Coopération Internationale en Recherche Agronomique pour le Développement (CIRAD) and made available on a CD-ROM.

Generally, the species inhabiting a particular area are known and local information will be available. However, in areas with more than one species present, it will be necessary for survey staff to be able to distinguish between species and this ability is not always available without some training on identification and the use of identification keys. In other areas, whilst one species may predominate there may be other species that are detected rarely and may be overlooked if insufficient attention is paid to identification. There are also countries in which tsetse subspecies coexist, for example, *G. m. centralis* and *G. m. morsitans* in Zambia; subspecies of *G. fuscipes* in Congo or *G. palpalis palpalis* and *G. p. gambiensis* in West Africa. These subspecies are not readily distinguished without microscopic examination, yet there are important implications to the targeting of just one of these subspecies in a control/eradication programme.

Distinguishing the sexes is relatively easy and quickly learned (FAO 1982a, section 1, these guidelines). Data for male and female captures should be analysed separately. The total of males and females should be added up for each day, either over all trap positions, or in each of the vegetation types or areas. Arithmetic mean catches per day per trap are then calculated for the full sampling period. The data can be displayed as a graph of numbers, on the vertical axis, against time, on the horizontal axis.

There are two commonly used types of logarithms, logarithms to base 10 (\log_{10}) and natural logarithms (\log_e — e is a constant equal to 2.71828). For the plot of numbers against time, natural logarithms should be used.

3.2.2. Trap and Tsetse Distribution Maps

The coordinates of all trap sites will be entered into a database and mapped on a base map of the survey area. This map can be updated weekly to display survey progress. This will be linked to data on trap catches so that weekly updated maps of tsetse distribution and apparent density can be produced on screen or as hard copies if required. There should be feedback of these maps to field survey teams to facilitate monitoring of progress and assess the need for any modifications of the survey protocol/work-plan.

3.2.3. Estimation of Apparent Density

It is not possible to precisely estimate the density of a tsetse fly population in a given area by trapping. All that can be done is to estimate the apparent density, changes in which are expected to roughly reflect changes in the real density of the population. The apparent density is relative to the type of sampling tool (trap) used, and is expressed as the average number of flies caught per trap per day (flies/trap/day or FTD). The apparent density is calculated by dividing the total number of tsetse flies captured (ΣF) by the product of the

number of functioning traps used to catch them (T) and the number of days for which the traps were operational (D).

$$FTD = \Sigma F / T \times D$$

If a trap is not operational for some reason, perhaps it was blown down or the cage was blown or knocked off, that trap day should be excluded from the sum of trap days.

The apparent density (AD) data can be grouped for analysis at different levels. Firstly, at the trap level, giving a mean AD per trap, this is at the highest resolution, but will be subject to great variability and would therefore have to be interpreted cautiously, according to the number of days of trapping that were grouped to calculate the mean. If there are sufficient data (many flies being caught), this can be used to produce a detailed map of the tsetse distribution of an area, especially if a 1 km²-grid survey was conducted. It can be useful in some circumstances to identify the vegetation types most associated with tsetse. The next level, to continue that association of tsetse with vegetation type would be to group traps deployed in the same vegetation type and determine the mean AD for those groups of traps. Thirdly, the traps in a particular grid can be grouped together and the mean apparent density for that grid can be estimated either overall, per season or per month (in the case of long-term monitoring rather than survey). The latter will give a general geographical distribution of tsetse by AD, not associated with vegetation. This can give an overview of a large area, but it must be borne in mind that with a 10 × 10 km grid square there could be a large amount of variation, depending on the uniformity of the habitat. Pooling the data in this way will reduce its variability.

Analyses of variance (ANOVA) can be used to explore the effects of the main factors, e.g. habitat type, sampling method on the dependent variables such as apparent density or trypanosome infection rates. Multiple regression analysis is also useful to determine the importance of different variables (study area, ethnic group, habitat, distance from river) in determining tsetse apparent density or presence and absence. A common procedure is to transform variables to a normal distribution; tsetse catch numbers are usually transformed by taking the logarithm of the numbers of flies (n)+1, whilst an arcsin transformation can be used for disease prevalence data.

3.2.3.1. Mark-Release-Recapture Studies to Estimate Population Size

For some purposes it is useful, if not essential to know the approximate size of a tsetse fly population in a given area. For example, for AW-IPM with an SIT component, knowledge of the approximate number of flies in the area will enable calculations of the number of sterile males that will have to be produced and released.

The mark-release-recapture method to estimate population size is probably the most appropriate for this purpose, although it requires a high degree of technical expertise and supervision, if it is to be used to produce estimates with a sufficient degree of reliability to be of practical use. For that reason it will not be a routine procedure in most surveys but will have a place in surveys that are conducted prior to programmes that envisage the use of the SIT. For good estimates to be made a sufficient number of marked flies have to be recaptured and that requires both a reasonably efficient trapping device and a reasonably

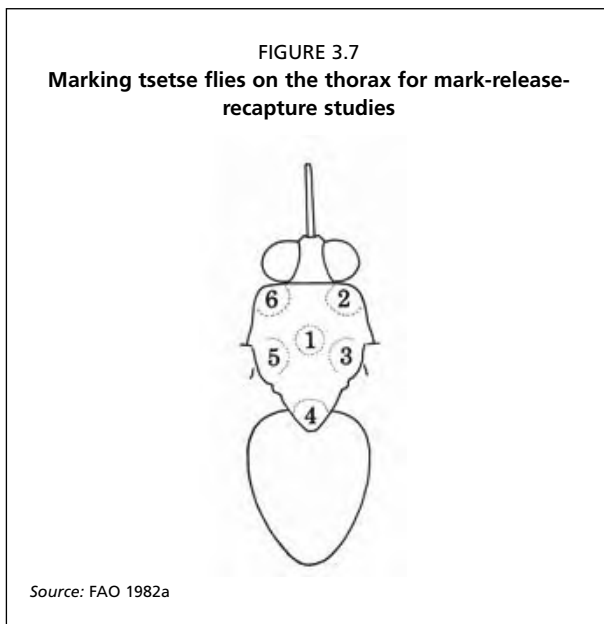

high natural population, as the proportion of marked flies that can be expected to be recaptured is relatively low.

The technique is as follows: tsetse flies are caught using a trapping device that will not damage the flies, leaving them with a probability of survival similar to that of uncaught wild flies after marking and release. The traps will be visited at short intervals (30 minutes) in order to process the flies before they have undergone stress in trap cages. Flies are marked, usually with oil paints, with a small spot on the thorax that will be readily seen if the fly is recaptured but which is not so big as to affect the flight and survival of the fly. Using combinations of different paint colours and different arrangements of marking the flies thorax it is possible to mark the flies in such a way as to enable the day of marking to be determined if the fly is recaptured (**Figure 3.7**). If, for example, one of the spots indicated in **Figure 3.7** is used to mark the month, a second site the week, and a third the day, using different colour codes on each spot, dates can be accurately marked and other spots can be used for other features, such as location.

The mathematics of estimating the population size, are relatively simple in theory — relating the proportion of marked flies recaptured and the proportion of marked flies in the total number captured during the occasion of that recapture to the total population size. However, there are various sources of error, such as the effects of immigration and emigration to and from the population and of birth and death rates that require more complicated mathematical procedures if accurate estimates are to be made. Within limits, a rough but reasonably accurate estimation will be sufficient for AW-IPM programmes that include an SIT component whilst more precise estimates will be necessary for research into tsetse population dynamics. Some of these procedures are reviewed by Leak 1998.

The Jolly method has been the most commonly used method to estimate the density of insect populations that are open, i.e. which are subject to emigration, immigration, birth and mortality, but the method requires that the release is made more than twice, which makes it logistically more challenging. Ito (1989) described alternative methods that could be based on a single-release and multiple recapture census for stable populations, i.e. the Hamada method (or modified Jackson positive method).

Flies can either be marked individually (e.g. oil paint spots) as described or group marked – marking large numbers of flies in the same way (e.g. with fluorescent paints or powders). Grass stems, fine brushes, or toothpicks can be used to mark the flies. It is important that the handling of the flies is minimal and does not affect their longevity or behaviour, that the marks do not fade, come off or in any other way become undetectable, and that the marked and unmarked flies can be captured with the same probability.

An index y_i is calculated by the following equation:

$$y_i = \frac{10^4 m_i}{M_0 n_i}$$

Where M_0 , n_i and m_i are, respectively, the number of individuals marked and released on day 0, that of individuals caught on day i , and that of marked individuals recaptured on day i . y_i is a standardized number of marked insects to be recaptured on day i , assuming that 100 marked insects are released on day 0 and 100 insects are randomly caught on day i . Provided that the wild fly density is constant, we can obtain a survivorship curve of marked individuals by plotting y_i against i . If the survival rate is constant it can be approximated by a linear regression equation:

$$\log y_i = \log y_0 + i \log S$$

Where S is the survival rate per unit time (as $S < 1$, $\log S$ is always negative). Here y_0 is a theoretical value representing an expected number of recaptures on the assumption that 100 marked individuals released on day 0 are instantly intermingled into the wild population, and that 100 specimens are randomly caught before either disappearance or dilution occurs. It is now possible to estimate the number of individuals as:

$$\hat{N}_{J+} = 10^4 / y_0$$

3.2.4. Blood Meal Analysis

Analysis of undigested blood meals collected from the midguts of tsetse flies will allow the predominant hosts of the tsetse fly to be determined. This epidemiological data can be linked to significant habitats that might be utilized by tsetse flies (coinciding with the host habitat). The data can also be used to determine what sort of suppression technique might be suitable; notably the use of insecticide-treated cattle (livestock) will depend upon the proportion of feeds being taken from those cattle. In areas where tsetse fly density is low, it can be difficult to collect adequate numbers of recently fed flies to provide a suf-

ficient sample size for statistically valid conclusions to be drawn on the feeding habits of the tsetse fly population.

It is important to catch recently-fed flies and consequently it is preferable to collect captured tsetse flies at shorter intervals than are generally used for tsetse fly surveys, for example, hourly or two-hourly collection during the periods of tsetse fly activity. Most tsetse fly traps catch a higher proportion of hungry flies, as those are the segment of the population that are more active, looking for a host to feed on.

Alternative methods of capture that have been used in the past are collection from resting sites using hand nets and the use of artificial refuges. Both of those techniques aim to catch flies that have recently fed and that are looking for a place to rest whilst digestion starts and some of the large volume of water content taken in with the blood meal is excreted, allowing the flies' flight performance to improve. Capture of flies with hand nets is tedious and requires skills in identifying appropriate sites and use of the hand net, furthermore, in most situations a limited number of fed flies are likely to be captured. During a survey, ideally, blood meal samples should be collected from transect catches to get an indication of spatial variability in tsetse feeding preferences.

Another problem is the insufficient sensitivity of the techniques used (complement fixation) leading to a high percentage of unidentified blood meals. There have been recent improvements with the use of a polymerase chain reaction (PCR)-heteroduplex technique that amplifies cytochrome B and can distinguish between different host species (Njiokou et al. 2004). When tsetse are dissected (e.g. to detect trypanosome infections) and it is noticed that the fly has apparently fed recently, to collect the sample for blood meal analysis, take the midgut with forceps, and spread it on a piece of Whatman paper, carefully writing on the paper the number of the tsetse, date, and trap number. Allow the sample to dry then put it in aluminium foil to protect it from dust. When the survey has finished, samples can be sent to a specialized laboratory for analysis.

A further difficulty with blood meal analysis is the availability of specialized laboratories that can undertake the analysis. In the past, free blood meal identification services have been available at the Imperial College, UK, and the Free University of Berlin, Germany however neither of these services is still available. Whilst international institutes (the International Livestock Research Institute (ILRI), the International Centre of Insect Physiology and Ecology (ICIPE), and the Centre International de Recherche Développement sur l'Élevage en zone Subhumide (CIRDES)) have previously offered this service on an occasional and limited basis, such services are also not currently available. The Farming in Tsetse Controlled Areas (FITCA) Kenya project established a blood meal analysis laboratory through provision of equipment and training of personnel, at the Kenya Agricultural Research Institute-Trypanosomiasis Research Centre (KARI-TRC) hospital at Alupe in western Kenya and this laboratory may provide the service in future.

3.2.5. Dissection

In this section, a description of basic techniques for dissecting tsetse for ovarian ageing and determination of infection rates is given. In guidelines such as these, it is possible to describe the organs that are to be dissected, to illustrate them with diagrams and to give

general principles of the way to dissect the fly. The only way to really learn dissection techniques is to closely observe it actually being done and to practice dissection.

3.2.5.1. Handling of Caught Tsetse

If tsetse are to be dissected then they should be processed as soon as possible after returning to the field station so that as many as possible are still alive for dissection. Trypanosomes are less likely to be found in dead, dried flies and, therefore, dissection results from such flies are likely to be underestimated and misleading. Consequently, dissections should only be carried out on freshly killed flies.

- store all trap cages carefully after removal from the vehicle to await processing — storage in a fridge (not freezer) is desirable as this will immobilize the flies without killing them and reduce likelihood of escapes,
- take one cage at a time and immobilize flies by squeezing the thorax gently whilst removing them from the cage,
- record the number of the cage on the trapping data recording sheet,
- if more than one tsetse species may be present, check each tsetse individually and identify the species using the appropriate keys (or parts of a key as the possible tsetse species for the area will be known). If two subspecies may be present in the same area this may require dissection (e.g. of the inferior claspers for *palpalis* group male tsetse; the signum of female *fusca* group tsetse),
- separate the males and females of each species — count each and record on the data sheet,
- count and record on the data sheet biting fly numbers (Tabanidae including *Chrysops*, *Haematopota*, and *Stomoxys* spp.) identified at least to genus,
- if required, biting flies can be preserved in 70% ethanol for subsequent species identification, otherwise discard,
- hand tsetse flies to dissecting team (if separate), maintaining trap identification, and
- proceed with next cage.

3.2.5.2. Equipment

A very useful tool for practical demonstration of dissection techniques is a teaching dissection microscope, which has two binocular eyepieces so that two people, the trainer and the trainee, can both look through the objective lens simultaneously. This allows the trainee to see exactly how the fly is being manipulated. A recently improved technological alternative is the use of a microscope connected to a monitor so that what is seen down the microscope is displayed on the monitor. One of these tools is recommended if a number of people are to be trained over a period of time.

Ideally, a dissecting microscope with fibre-optic illumination (cold light) should be used as this will prevent the saline buffer in which dissections are carried out from drying too rapidly. Dried saline will leave white crystals and dried tsetse organs will easily disintegrate and will be impossible to observe clearly.

3.2.5.3. Dissection for Wing Fray Analysis, Size Estimation and Determination of Ovarian Age

Determination of the physiological age structure of a tsetse population is of great importance in evaluating the progress of control/eradication programmes, especially those in which aerial spraying or SIT are used. During sequential aerial spraying of non-residual insecticides any tsetse captured within a spray block in the few days after spraying should be young flies that have just emerged from pupae in the ground. Any older flies captured must either have entered the spray block from the neighbouring area — indicating problems of re-invasion — or must result from some fault in the spraying operation.

Wing fray analysis

Relative age structure of a tsetse fly population can be determined for male and female flies by analysis of wing fray, although this is crude and subject to variability between species, sexes and seasons. Nonetheless, for pooled samples for each sex and species separately, it is a simple technique and can give a useful indication of changes in population age structure:

- gently but firmly squeeze one fly to immobilize it,
- with a pair of fine (watchmakers) forceps remove each wing from the fly, pulling from the base of the wing, taking care not to damage the trailing edge,
- place the wings on a slide with a drop of saline solution (or water) and place a cover slip on top,
- examine with a dissection microscope 25× magnification. Select the least damaged wing (to minimize overestimating wing fray (resulting from damage caused in the trap cage) and assess the degree of wing fray by making reference to **Figure 3.8**

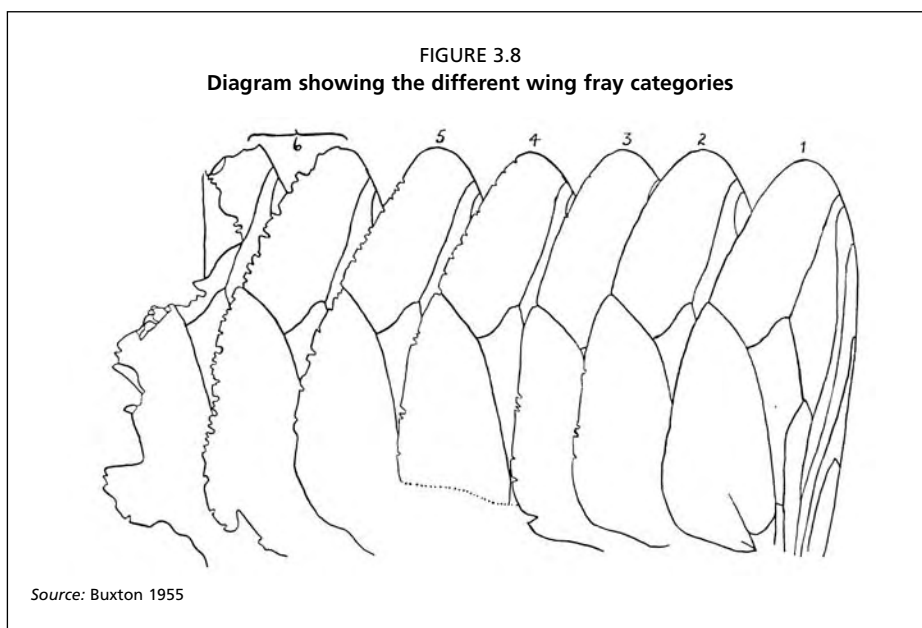

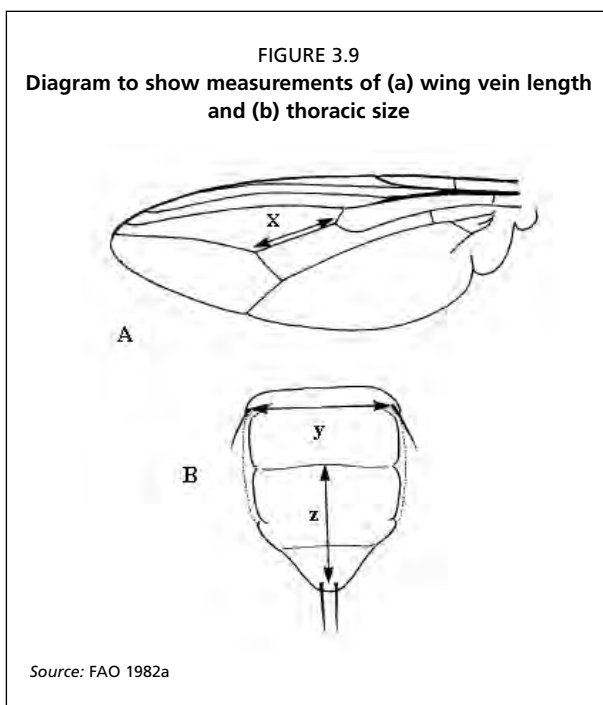







(with experience it is soon possible to distinguish between genuine fraying due to age and damage caused by handling/the trapping process), and

- record the wing fray category along with other details of the fly (species sex, trap number and date) on the recording sheet. Further details of the methodology for wing fray ageing techniques are available in the FAO training manual for tsetse control personnel, volume 1 (FAO 1982a) or Mulligan (1970).

Measurement of wing vein length

Whilst examining the wings for wing fray, a further procedure that can be carried out in order to obtain an estimate of the mean size of flies in the population is measurement of the wing vein of the hatchet cell (blade) as indicated in **Figure 3.9, upper**. Size-dependent mortality is known to occur in *G. morsitans* and *G. pallidipes*, and hence, changes in mean size of the population can therefore be used to estimate changing mortality rates. The measurement requires a graticule that is used in conjunction with the microscope and requires care in accurately measuring the vein length; otherwise the results will be meaningless. This is one of the reasons why dissections should all be carried out by a separate team from those conducting the survey trapping as if time is limited, insufficient care will be given to the dissections. The thorax size can also be measured across the dimension shown in **Figure 3.9, lower** as an additional measurement of size. Recently, more sophisticated morphometric methods of analysis have been developed (Patterson and Schofield 2005) as outlined in 3.3.3.

FIGURE 3.10
Ovarian age categories

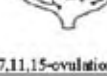
Ovarian age category	Configuration	Category / uterine contents	Estimated age (days)	Later category	Age range
0	 Non-ovulated	=	0-8	8a	80-84
				8b	84-87
				8c	87-90
1	 1-ovulation	1a	8-12	9a	90-94
		1b	13-16	9b	94-97
		1c	16-19	9c	97-100
2	 2-ovulations	2a	20-24	10a	100-104
		2b	24-27	10b	104-107
		2c	27-30	10c	107-110
3	 3-ovulations	3a	30-34	11a	110-114
		3b	34-37	11b	114-117
		3c	37-40	11c	117-120
4	 4,8,12-ovulations	4a	40-44	12a	120-124
		4b	44-47	12b	124-127
		4c	47-50	12c	127-130
5	 5,9,13-ovulations	5a	50-54	13a	130-134
		5b	54-57	13b	134-137
		5c	57-60	13c	137-140
6	 6,10,14-ovulations	6a	60-64	14a	140-144
		6b	64-67	14b	144-147
		6c	67-70	14c	147-150
7	 7,11,15-ovulations	7a	70-74	15a	150-154
		7b	74-77	15b	154-157
		7c	77-80	15c	157-160

Source: FAO 1982a

Dissection for ovarian ageing

A more accurate method of ageing tsetse, applicable only to female flies, is the determination of their age based upon ovarian dissection (**Figure 3.10**) to determine the number of eggs produced by the female and the stage in the ovarian cycle at the time of dissection. This dissection technique, obviously for female flies only, requires some practice, ideally with tsetse of a known age before reliable results can be obtained so it is less appropriate for instructions of the sort provided here, it requires demonstration.

Guidelines for ovarian dissection

To dissect a female tsetse fly for ovarian ageing, first remove the wings and legs of the fly with fine forceps, simply because these may otherwise get in the way of the dissection.

Place the fly with its dorsal side uppermost on a glass slide with some buffered saline sufficient to prevent the dissected organs from drying out. Make an incision of about one mm on either side of the fifth or sixth tergite. Gently grip the tip of the abdomen below the incisions and pull backwards. A side-to-side movement will assist in tearing the abdomen across. When the abdomen tears, the internal organs will be exposed and should float in the phosphate buffered saline buffer so that the uterus, spermathecae and ovaries can be readily seen. Check the position of the spermathecal duct entering the uterus as this will indicate whether the reproductive organs are in the correct configuration or if they have become twisted or turned over. Observe the contents of the uterus, and if required, the percentage of sperm in the spermathecae. Make an initial observation of the configuration of the ovarioles, i.e., is the most developed on the left inside, left outside, right inside or right outside? Do the same for the next in size and so on. This will let you compare with the diagram in **Figure 3.10**, to determine the physiological age of that female fly. It will also enable you to determine which ovarioles you need to dissect to look for a follicular relic. Having determined that, remove fat bodies and other parts that might get in the way, then, using a higher magnification use fine mounted needles or good quality fine forceps to break the outer membrane of the ovarioles and release the developing egg.

This can then be examined for the presence or absence of a follicular relic. In some age configurations, there is only one possibility to look for a relic and if the dissection is messed up, for example because the egg is broken, there is no possibility to go further. In other configurations there can be a second chance if the first one is unsuccessful.

The key to success, is keeping the tissues moist, avoiding twisting or turning of the reproductive system and careful dissection avoiding puncturing of developing ovaries. If they are punctured, whitish contents come out and it becomes impractical to reliably observe the status. When correctly positioned the spermathecal ducts should be seen entering the uterus from above — provided the right and left ovaries have not twisted, they should then be in the correct position to determine which is the largest ovariole and the sequence. You can also verify that the order is in the correct configuration.

If the gut is full, contents of the gut, when broken can obscure the reproductive system, so when dissecting, don't pull the abdomen so far back that the gut is broken.

The gut may be carefully detached near the rectum to remove the fly's body from the reproductive organs afterwards.

Drawbacks to ovarian ageing are that it requires a skilled technician to perform the dissection accurately and that skill requires not only adequate training, with tsetse of known ages available for verification, but also a sufficient amount of practice. Training can be given but without sufficient practice and experience the validity of data obtained may be questionable. For that reason attempts have been made to develop automated methods for age determination, for example, based upon pteridine accumulation in the compound eyes, however, these attempts have met with difficulties and are not yet available for routine use. The methodology for ovarian dissection is described further in Mulligan (1970) and the FAO training manual for tsetse control personnel, volume 1 (FAO 1982a).

It is important to emphasize that ovarian ageing of female tsetse provides the dissector with the physiological age of the fly, not the calendar age (as the development of the ovaries is temperature dependant).

3.2.5.4. Dissection for Trypanosome Infection

Trypanosome infection rates in tsetse can be determined either by dissection and observation of the parasites in organs of the fly (based on which, an imprecise identification of the trypanosome species subgenera can be made), or using molecular biological diagnostic procedures (DNA probes and polymerase chain reaction (PCR)). There are advantages and disadvantages to both methods. The basic dissection method is crude as it cannot precisely identify the trypanosome species. Inaccuracies can also result from mixed infections, immature infections and the inability to distinguish between some trypanosome species of the same group that are pathogenic to domestic livestock or humans or not, e.g. *Trypanosoma simiae*, which is indistinguishable from *T. congolense*, but which, although it can be pathogenic to domestic pigs, is primarily a parasite of warthogs and is not pathogenic to cattle. Diagnosis based on molecular biological techniques is not very different in sensitivity to the microscopical technique, but can accurately identify the trypanosome species. A drawback of PCR is that it requires sophisticated laboratories, specialist staff and reagents and is more expensive to perform. Problems have arisen in the past with trypanosome strains for which primers were not available. For most tsetse surveys associated with control/eradication programmes it is likely to be sufficient to determine trypanosome infection rates based on dissection alone, however, subsamples could be collected for diagnosis by molecular techniques if required and when possible PCR could be performed on mouthparts only, as this will give a rapid estimation of mature infections and will save the time and money used to identify trypanosomes in the midgut, which is less useful because it is known that a large proportion of trypanosome infections in the guts of tsetse do not mature.

Guidelines for trypanosome infection dissection

- Put the fly on its back in the middle of a glass slide with a drop of saline solution or phosphate-buffered saline (PBS) if available,
- looking at the fly through a dissecting microscope at low magnification, use a pair of fine, spring scissors to make an incision in each side of the abdomen close to the thorax,
- holding the thorax of the fly with one pair of fine forceps, use a second pair to grip the base of the abdomen and gently pull back the abdomen so that the "skin" slowly tears whilst the gut and other internal contents stretch out but do not break,
- in the drop of saline solution the salivary glands can usually be seen, one on either side of the gut, as clear, silvery transparent tubes; use one pair of fine forceps to carefully pick up each of these glands, pull from the fly and place on a separate part of the slide with a drop of saline and cover with a cover slip,
- remove the head and thorax of the fly to the other end of the thorax, cutting the gut close to the thorax,
- with the flat part of a mounted needle, squeeze the abdominal contents out from the "skin" into the middle of the slide,

- discard the abdomen skin,
- place a cover slip over the gut contents and a drop of saline and press down gently,
- move the slide so that the end with the head is visible under the dissecting microscope; increase the magnification if necessary,
- cut the head off from the thorax and discard the thorax,
- with the head upside down on the slide hold the head with a pair of forceps and use the flat surface of a mounted needle (not the point) push down and forward so as to push the whole proboscis away from the head so that it detaches. The head can then be discarded or stored separately (for pteridine age analysis), whilst retaining the proboscis on the slide,
- increase the magnification as required so that the proboscis is clearly visible under the microscope. Use two mounted needles, one in each hand, to tease apart the labrum, hypopharynx and labium, starting from the end of the proboscis with the thecal bulb. Take care not to tear the structures rather than tease them apart, otherwise some tendon-like organs can sometimes be confused for the hypopharynx by an inexperienced dissector,
- discard the thick, brown labium as this will prevent the coverslip from sitting correctly over the mouthparts and will obscure vision,
- place a cover slip over the labrum and hypopharynx, with a small drop of saline,
- examine each of the organs, the labrum, hypopharynx, salivary gland and midgut for the presence of trypanosomes which, if present will be seen usually in motion, under a compound microscope using a 10× eyepiece and 25× objective, and
- record the presence of trypanosomes under the appropriate column of the recording sheet. If no trypanosomes are seen, record as negative.

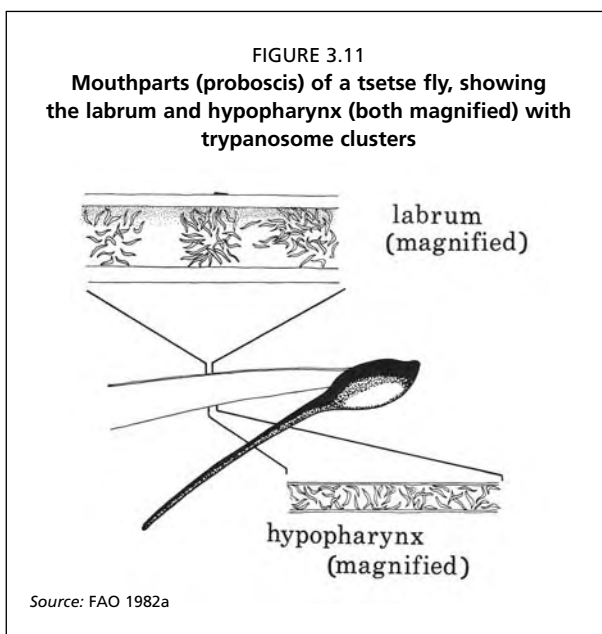

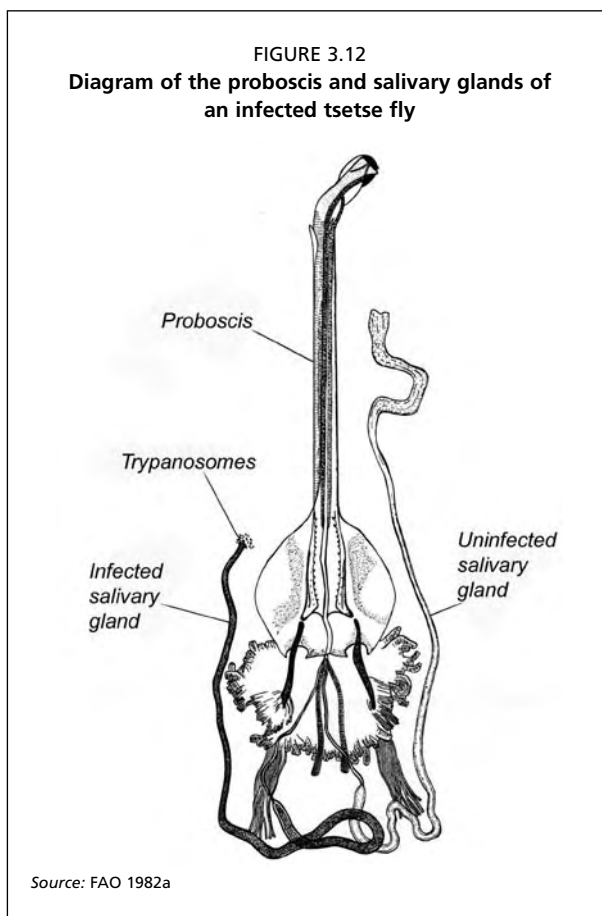

As the hypopharynx is a very fine transparent tube, avoid putting too much saline solution or the hypopharynx can float away and be difficult to relocate. It is helpful to place the hypopharynx across the labrum on the slide as they will usually stay together and avoid the problem of finding the hypopharynx after putting on the cover slip. If the proboscis is torn, rather than being teased apart, there are two transparent tendon-like structures that people may mistake for the hypopharynx; they should be easily distinguished, firstly because there are usually two of them seen rather than just one, secondly, because there is a tuft of (muscle) fibres at one end, and thirdly there are rings at intervals along their length, a bit like the rings on bamboo, whereas the hypopharynx is a plain, hollow transparent tube.

Trypanosome infections in the hypopharynx and labrum (proboscis) only, are classed as *Trypanosoma vivax*-type; in the proboscis and midgut only as *T. congolense*-type and in the proboscis, midgut and salivary glands as *T. brucei*-type. If an infection is detected in the midgut alone, that is classed as an immature infection (**Figure 3.11 and 3.12**)

Don't use needles that are too fine and sharp as they can tear the labium.

It is important to dissect out the hypopharynx as it is the site of maturation of *T. congolense* and *T. vivax*-type trypanosomes.

Good practice is to place the labrum and hypopharynx crossed over each other prior to dropping a cover slip on them as otherwise, when the cover slip is put on the hypopharynx may float away, and if it floats to the edge of the cover slip it is difficult or impossible to observe.

3.2.5.4.1. Salivary Glands

There are two main methods of dissecting out the salivary glands and either may be used according to personal preference. It is also usually possible to use the second method if the first fails.

Dissection method 1 — A simple and clean method, if it works, is to hold the fly by the thorax, on its back in phosphate buffered saline, after having removed the wings and legs and with a second pair of fine forceps held between the head and the thorax, but not closed or squeezing the neck gently and slowly move the head away from the thorax, moving the forceps from side to side to facilitate the gentle breaking of the external membrane of the “neck” without a sudden break which might jerk the head forward and break all the internal tissues including the salivary glands. If this is done carefully, the salivary glands will emerge cleanly, initially sticking together as one; the head can continue to be moved forward gently and a surprising length of salivary glands will emerge, separating into two distinct glands as they float in the phosphate buffered saline. After the first stage, in which the glands are thin, it becomes less likely that they will break and they can be pulled all the way out and covered with a cover slip. If however, they break they will retract into the thorax and abdomen and it will be difficult to retrieve them, although this is sometimes possible if they have not gone all the way inside the thorax — they are quite elastic. If the salivary gland do go back inside it is still possible to get them using the second method, as they have not disappeared.

Dissection method 2 — The second method is to make two small incisions on either side of the tergites close to the thorax (tergites 1–3), with the fly on its ventral surface. The “skin” of the abdomen is then pulled back with a side to side motion with forceps, whilst holding the thorax with a second pair. When the “skin” breaks, provided the dissection is done in a drop of phosphate buffered saline the internal organs should separate as they float, revealing the gut in the centre, with one salivary gland on either side. Sometimes, especially in an older, well-fed fly, they may be obscured by fat bodies and sometimes people mistake the malpighian tubules for the salivary glands. With a little experience however, the salivary glands are easily recognized by their translucent nature and structure of the outer membrane.

Don't let the salivary glands dry up as they are pulled out using the first method, as they will break very readily.

Don't pull them out too fast but be patient and slow.

When using the second method, again, make sure that the organs come out floating in saline.

The first method is preferable as there is less likelihood of trypanosomes from an infection of the gut being present in the phosphate buffered saline surrounding the salivary glands and being mistaken for a salivary gland infection.

3.2.5.4.2. Dissection of the Midgut and the Proventriculus

This dissection is the easiest to perform. After dissection of salivary glands using method 2, the residual contents of the abdomen can be put under a third cover slip after first removing the fat bodies and part of the hind gut.

Removal of the fat bodies and the hind gut, particularly in a recently fed fly will make examination easier as they will otherwise obscure the view, making detection of trypanosomes less easy.

Use light pressure on the cover slip to squeeze out the gut contents before examination.

Collection of samples for identification using PCR or other molecular diagnostic techniques — If facilities are available, or can be arranged for PCR identification, then the following methodology should be followed for collection of samples.

The standard procedure is to dissect out the organs of tsetse in which the trypanosomes are known to occur (mouthparts, salivary glands and midgut), and to grind these organs up before DNA extraction. In order to avoid contamination, the dissection instruments must be carefully cleaned between the dissection of each fly and also between the dissections of each organ of the fly. This cleaning is done first in a bath of sodium hypochlorite bleach, followed by rinsing in sterile distilled water. The proboscis is dissected from the fly first, followed by the salivary glands and lastly the midgut. After dissection, the organs (proboscis, salivary glands and midgut) will be stored separately; suspended in 50 µl of sterile distilled water in a sterile, sealed eppendorf tube, or in 70% alcohol before sample preparation. DNA extraction is now carried out using resins (Chelex®, Ready-Amp®) or commercial kits (Qiagen®, DNAzol-BD / polyacryl carrier®). The midguts and mouthparts need to be treated prior to the PCR but salivary glands can be processed directly after lysis in distilled water and/or by freezing/thawing (Lefrançois et al. 1998, Desquesnes and Davila 2002, Jamonneau et al. 2004).

How many flies should be dissected? — The answer to this question will depend on how many tsetse flies are expected to be caught. If the area is one of low density or if the procedures are being carried out after suppression, then a larger proportion (all live or fresh flies) will be dissected. The need is to dissect a sufficient number to provide a statistically acceptable estimation of the trypanosome infection rate or of the age structure of the population for each tsetse species. A target of 100 flies per sampling occasion period (or per month in the case of monitoring rather than survey) per species will enable seasonal patterns of infection or of changes in population age structure to be observed. There is generally small variation in trypanosome infection rates in a population over time in the absence of any external intervention. For age structure the dissections should be made over as short a period as possible. Dissection of 100 flies should be quite manageable in terms of the time required to dissect them, but even this relatively low number may be

hard to attain in some areas, in which case all live tsetse caught should be dissected. If there are distinct areas within the survey block, from which different infection rates might be expected, and if such a degree of epidemiological knowledge is required, then samples as above will be dissected from each such identified area. For most circumstances this will not be necessary.

3.2.6. Population Dynamics and other Entomological Assessment

There are a number of techniques used for specific purposes that may or may not be included in a baseline survey, but are more likely to be employed during monitoring. However, it may be necessary to obtain such data during a survey for future comparison with post-intervention data.

Determination of insemination rates — by dissection of females and noting the proportion of the spermathecae that are filled with sperm (usually expressed in quarters). This is a simple dissection (**Figure 3.13**) that provides useful information for SIT programmes and does not require a great deal of skill.

Mortality rates — can be determined indirectly by determining changes in the population and the population age structure over time. Size frequency distributions, estimated from wing-vein length (hatchet cell length; **Figure 3.9**) can also be used to give an indication of mortality rates (see Leak (1998) for a review of procedures for determining mortality). The nutritional status of a population can be determined by estimating the amount of fat and haematin (a product of blood digestion) in a sample of flies.

Temporal and spatial distributions and variations of the structure of a fly population — The spatial distribution of a tsetse population in grid squares/vegetation zones is important for the development of suppression strategies and for the selection of trapping

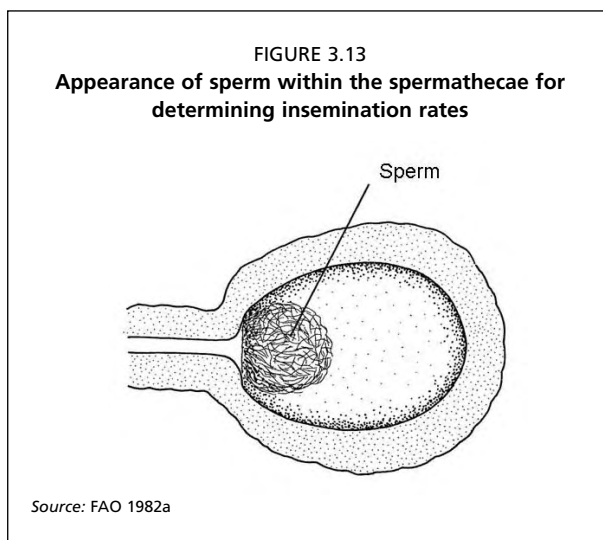

sites for the monitoring programme. In practical terms, populations with a uniform distribution may be less complicated to suppress than a population aggregated into discrete foci (e.g. the Niayes infestation (orchards) in Senegal).

Calculating apparent density of *G. fuscipes* or other riverine flies based on a grid square value can be misleading as they are assumed to be relatively restricted to riverine vegetation cover.

Basic data on spatial distribution of tsetse in the survey area and their apparent densities determined at different seasons will enable the seasonal movements of tsetse to be assessed with respect to altitude and vegetation/climatic characteristics. These data will enable rates of dispersal throughout the area to be assessed. Analysis of the structure of the population in terms of its age and sex ratios will also contribute to planning of control/eradication.

3.3. GENETIC ANALYSIS

3.3.1. Objectives of Genetic Analysis in the Context of AW-IPM Programmes

One purpose of genetic analysis of tsetse flies may be to determine the degree of genetic isolation of neighbouring populations. This will contribute to determining whether or not a population is really isolated from another or whether there is gene flow, indicating movement of individuals between those tsetse populations. This is obviously important when considering AW-IPM, as re-invasion of cleared areas has to be prevented.

Despite the relatively low ability of tsetse flies to disperse, in comparison with other dipteran pests such as screwworm flies, there is a high potential for fly re-invasion into areas where control operations have been undertaken. Especially with *palpalis* group tsetse flies, which are considered to be quite restricted to riverine vegetation, it is often difficult to determine the extent to which they can disperse from one area of suitable habitat (river system) to another. An indirect method of determining the likelihood of this is through genetic characterization. Subpopulations, or demes, that exchange flies will be genetically much more homogenous (same gene frequencies) than those between which there is little or no genetic exchange (different gene frequencies). PCR techniques can now be used to rapidly characterize tsetse populations genetically, using either mitochondrial or microsatellite DNA markers (Solano et al. 1999, 2000, Krafsur 2003, Marquez et al. 2004). It is therefore desirable to collect samples for this purpose from the target area being surveyed and from neighbouring areas of tsetse infestation. Results of such analyses will contribute to confirming or otherwise, the assumed degree of isolation of the target population. Obviously this should be carried out early in the planning stage.

Recent studies using remote-sensing technologies have shown that in areas subject to human encroachment (in East and West Africa) tsetse fly populations become fragmented and in some cases isolated. Finding these "biological islands" by assessing their genetic isolation will undoubtedly help to target these populations for sustained vector control, possibly even eradication. However, such populations need to be identified and characterized prior to control operations. Molecular and morphometric techniques seem to have the potential to rapidly identify the levels of epidemiologically important population substructuring in tsetse vectors.

3.3.2. Principles of Genetic Analysis

The null hypothesis is the Hardy-Weinberg rule stating that gene frequencies will be homogeneous among sampled populations if matings are random, the genetic variation selectively examined is neutral, the mutation rate is negligible, and the sampled populations are infinitely large. Most deviations from these initial assumptions are caused by departures from random mating within and among populations and population sizes that are not large. Thus, we can test hypotheses about gene flow and population sizes by sampling a series of populations and estimating the amounts and spatial components of gene diversity.

With free exchange of reproducing flies and random mating, gene frequencies in populations approach homogeneity, and among-population variance in gene frequencies is small. Variance in gene frequencies increases with greater genetic divergence. The standardized variance in gene frequencies among subpopulations is termed F_{st} . F_{st} represents the departure from random mating *among* subpopulations. The departure from random mating *within* subpopulations is F_{is} and this statistic is normally close to zero (Weir and Cockerham 1984). An F_{is} estimate significantly greater than zero, when averaged over loci, can indicate that the sample contained individuals from two or more subpopulations that differ in their allelic frequencies — the Wahlund effect. F_{st} can be related to migration and dispersal by various theoretical models. According to Wright's island model, the mean number of breeding migrants, Nm , in a generation is related to F_{st} , thus $F_{st} = (1 + 4Nm)^{-1}$. In principle, numerically little gene flow among populations prevents genetic differentiation by drift (Gooding and Krafur 2005).

3.3.3. New Possibilities: Geometric Morphometrics of Tsetse

Morphometric characters are related to growth and development, and they are usually continuous. Traditionally, they were estimates of distances between anatomical points called landmarks ("Traditional morphometrics"). More recently they have come to be the coordinates of these landmarks in a given system of orthogonal axes ("Geometric morphometry") (Rohlf and Marcus 1993). The few examples of the use of geometric techniques in medical entomology are found in Phlebotominae (vectors of Leishmaniosis) and Triatominae (vectors of Chagas disease), and very recently this technique has been shown to be promising in tsetse flies (Patterson and Schofield 2005). These examples indicate that geometric morphometry makes it possible to distinguish species, subpopulations, ecotypes and even successive generations by the configuration of a few landmarks on the wings (**Figure 3.14, upper**). Besides its evident contribution to insect systematics, the main epidemiological contribution of morphometrics to medical entomology has been to help decision making in the development of vector control strategies: thus, it has been possible to recognize the geographic origin of invading or re-infesting specimens (Dujardin et al. 1997). The high discriminatory power of geometric morphometrics could be used here to delineate natural barriers between subpopulations within the main species.

A significant advantage of this technique compared to others is the simplicity of data acquisition and its low cost. Basic laboratory equipment needed consists of: a mono- or binocular microscope, a simple scanner, a computer. Specialized software is freely available at <http://www.mpl.ird.fr/morphometrics>. Raw data collected from the wing consists of a set of coordinates corresponding to a few homologous, landmarks. The main lines of the

FIGURE 3.14
Example of geometric morphometrics of tsetse wings

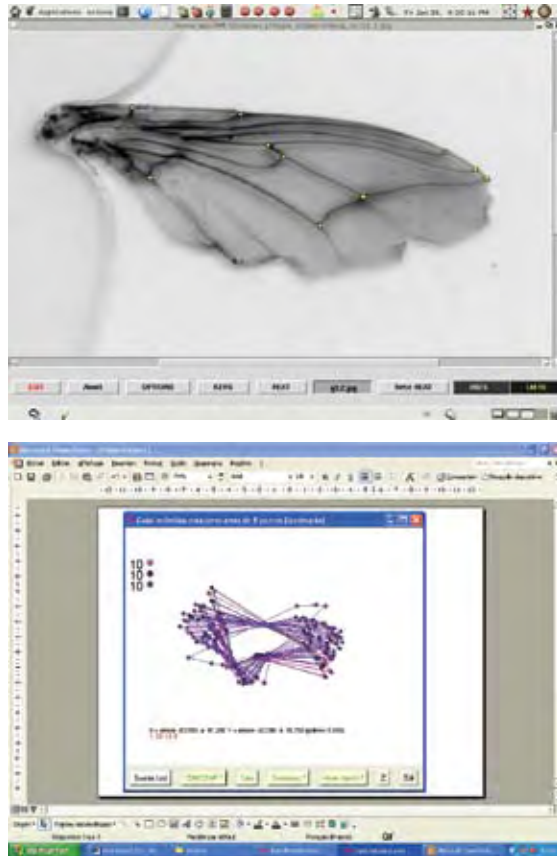

(upper) scanned wing with ten easily identifiable landmarks for geometric morphometrics; (lower) scanned wings (here, for instance, three samples of ten flies, each) have been transformed into polygons and are ready for shape analysis

J.-P. DUJARDIN AND P. SOLANO, IRD

analysis are the computation for each wing of one estimator of size, the “centroid size”, and of a set of shape variables called “partial warps”.

The “partial warps” are then used as input for any kind of multivariate analysis comparing groups, populations or species. Size may be studied separately by univariate analysis. The independence between size and shape is generally good, and may be measured by regression techniques. The possible differences among groups may be directly visualized by the technique of “thin-plate splines”.

3.3.4. Collection of Samples for Genetic Analysis

3.3.4.1. Sample Size

The analysis can be carried out on small numbers of flies — a target number of 30 flies (ten males and 20 females) from each species and from each area suspected to be geographically isolated are sufficient.

3.3.4.2. Preservation of Fly Samples

The flies can be dried immediately after capture, to avoid them becoming contaminated with fungus or rotting, or can be preserved in alcohol (70% ethanol). Flies from different locations should be stored in separate labelled containers.

Ideally, when flies have been caught and given to the dissection team, processing would be recommended for each fly as follows:

- wings should be carefully removed with forceps and stored in separate, labelled, eppendorf tubes for subsequent morphometric analyses,
- for genetic analyses, using microsatellite DNA markers only two to three legs of each fly need to be taken and also put in numbered eppendorf tubes. For studies using mitochondrial DNA the whole tsetse individual is required,
- hence, each fly needs to have a unique identifier related to the identity of the trap, which will allow its genotyping and morphometric identity,
- before embarking on the collection of samples for genetic analysis, it is necessary to identify a laboratory at which the analyses can be carried out and make the necessary arrangements. There are currently no commercial laboratories providing that service and analyses generally are part of a research project. Among the potential laboratories that may have an interest, and currently have the capacity for genetic analysis are the FAO/IAEA Agriculture and Biotechnology Laboratory in Seibersdorf, Austria, the Centre International de Recherche Développement sur l'Élevage en zone Subhumide (CIRDES), Bobo Dioulasso, Burkina Faso, the Department of Entomology, Iowa State University, USA and the L'Institut de Recherche pour le Développement (IRD)/Centre de Coopération Internationale en Recherche Agronomique pour le Développement (CIRAD) (IRD/CIRAD) in Montpellier, France.

3.4. REPORTING

On completion of a survey the procedure and results have to be adequately reported, whether it be to a government ministry, donor(s), in a scientific journal, conference proceedings, elsewhere, or in a combination of those forms. This will provide a historical record of what was done, of the methodology that was used and of the results obtained that could then be used for planning future activities.

The report should follow a standard format, providing all the necessary information required for a person who was not involved in the survey to understand and interpret the data at some time in the future. The suggested layout is as follows:

1. Introduction

This should explain the problem that is being addressed, the reasons for undertaking the survey and its objectives.

2. Materials and Methods:

Study area — Describe the geographical location of the study area, how it was chosen and its descriptive characteristics with regard to climate, vegetation, geography, etc. Maps should be included here illustrating the location of the site in relation to the country/region. In addition to a basic map indicating the location, a land use or vegetation map of the area needs to be included (e.g. **Figure 3.15**) in order to describe the planning of the survey and to further describe the area. Reference will be made to any previous knowledge of tsetse distribution and abundance from the same location.

Materials used — Give details of the type and source of satellite images used and of how they were interpreted.

Survey design — This section will describe the number of sampling sites, the way in which they were selected, and their locations and other characteristics. The sampling method need to be described, along with the justification for selecting that method. Other information will include all the relevant description of the survey procedures such as when it was done (year and seasons), methodology of the sampling (how many times in a day, what time, what was done with the flies caught, what parameters were recorded for the flies and for other survey components, e.g. climate).

Statistical analysis — Commonly, data on fly density is transformed to normalize the data, i.e. to transform the data to a normal distribution, and logarithmic transformations are often chosen as the most appropriate. This section should describe the type of transformation, if any, carried out and the reasons for doing so. In epidemiological surveys in which data on disease parameters are collected, or where environmental

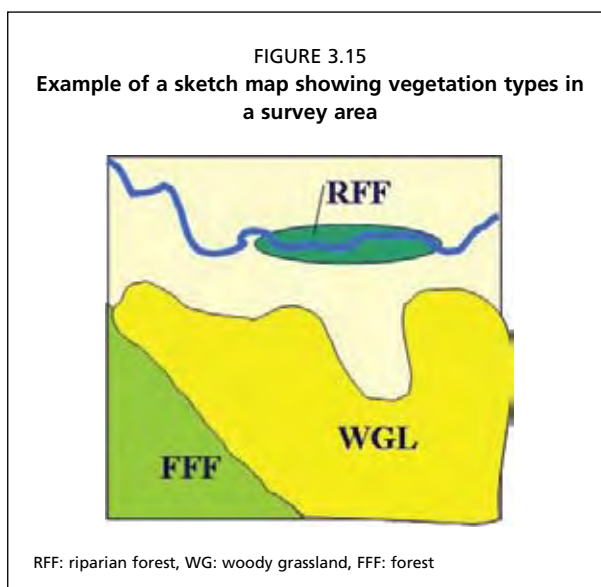

parameters are measured (rainfall, vegetation type, etc.) statistical tests are likely to be carried out to explore relationships between these various parameters. These and any other statistical treatment of the data are described in this section.

3. Results

How many flies? What species? What was the apparent density? What was the spatial distribution? What was the seasonal effect? What relationships were detected with vegetation and climatic factors?, etc.

4. Discussion

What do the results signify? How do they compare with what was found previously/elsewhere? What lessons were learned from the survey methodology? What will be done next?

5. Conclusions

What is the outcome of the survey? For example, would a control or eradication programme be recommended or did the survey results suggest that this would not succeed or would not be feasible within the available budget. What next steps might need to be undertaken based on the outcome of the survey?

Ideally, maps of the survey results should be made available in the public domain (e.g. GeoNetwork (Cecchi and Mattioli 2007, Cecchi et al. 2008) under the auspices of FAO) in order to make available updated continental tsetse distribution maps.

3.5. EXAMPLES OF GRID-BASED TSETSE SURVEYS

3.5.1. Togo

In Togo, to allow systematic country-wide surveys, the country was divided up into grid squares or sample units measuring 0.125° latitude/longitude. This raster, or grid base of 311 identical cells was used for the sampling frame. Different variables were sampled in every grid square (**Figure 3.16**) for a country-wide survey of tsetse flies and other related epidemiological parameters (Hendrickx et al. 1999).

The survey in Togo was conducted not with an immediate view to control or eradication but to produce country-wide distribution and abundance maps for ecological and epidemiological analysis that could be used for planning future activities. The survey made use of grid-based (raster) surveying and recording of data in an area infested with *G. tachinoides*, *G. p. palpalis*, *G. m. submorsitans*, *G. longipalpis* and *G. fusca fusca*. In order to obtain grid cell-specific fly density values, 1:200 000 maps were consulted to select survey sites representative in terms of the prevailing dominant vegetation types, and also taking into account the local drainage systems and the accessibility of the terrain. Locally, within each site, the field teams selected what they perceived to be suitable tsetse habitats according to expected fly species, and positioned clusters of a minimum of five and an average of 12 tsetse traps for 24–48 hours. Thus a total of 653 different survey sites were sampled in 305 of the 311 grid squares comprising 14 620 trapping days.

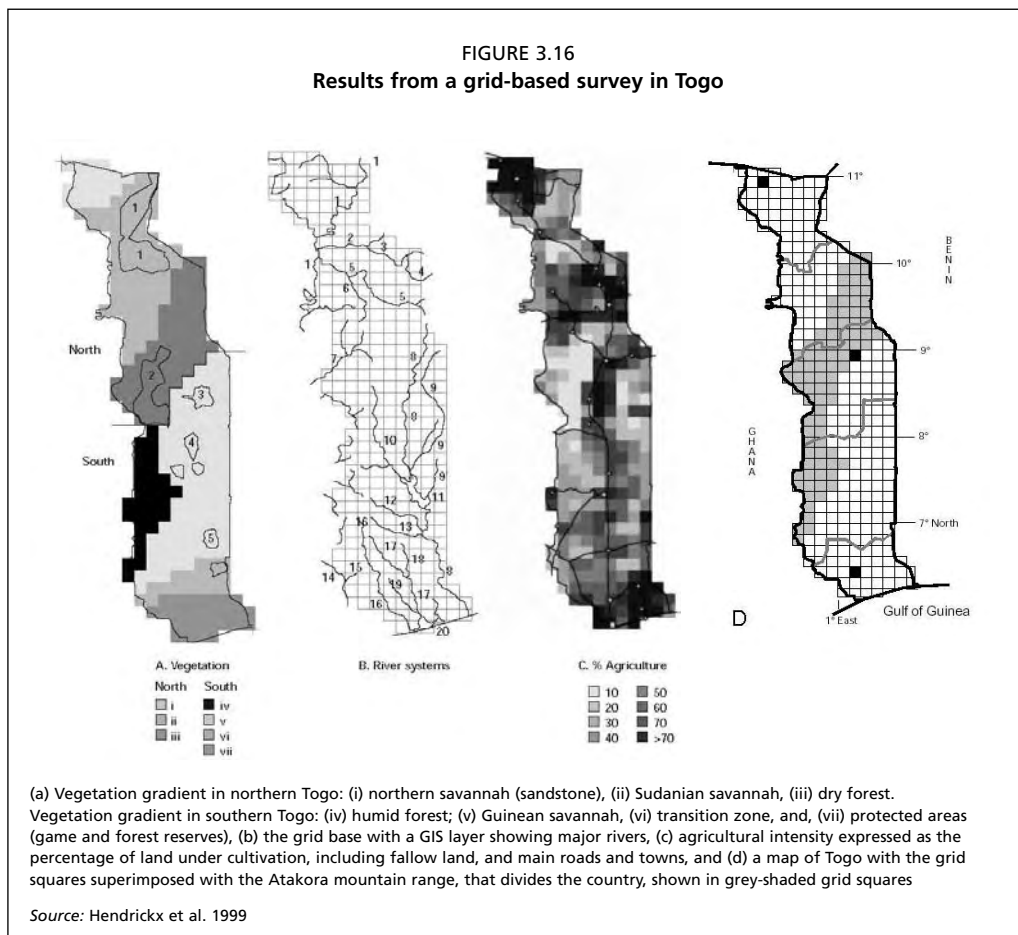

The tsetse survey took place in 305 grid squares with an average of 12 biconical traps per trapping site. On average 2.1 sites were sampled per grid square for 24 or 48 hours. As sampling took place at different seasons at different locations within the country, the data were processed to make seasonal adjustments and for spatial smoothing. Spatial smoothing was done to reduce the amount of random variation by using a GIS tool to average each grid value with that of the eight, or less, adjacent grids. Using the same technique it was possible to “estimate” the likely value for grid squares for which no data were obtained. Hendrickx et al. (1999) believed that after spatial smoothing, the prevalence maps produced revealed better and more accurate patterns than those produced directly from raw data. Efforts concentrated on the precise limits at the edges of the fly distributions (**Figure 3.17**).

In terms of logistics, the Togo survey was conducted by five different mobile teams operating simultaneously. Each team was assigned one out of five administrative regions of the country, roughly corresponding to a 1:200 000 map each. The country was divided into four major seasonal clusters from dry monomodal in the north to wet bimodal in the

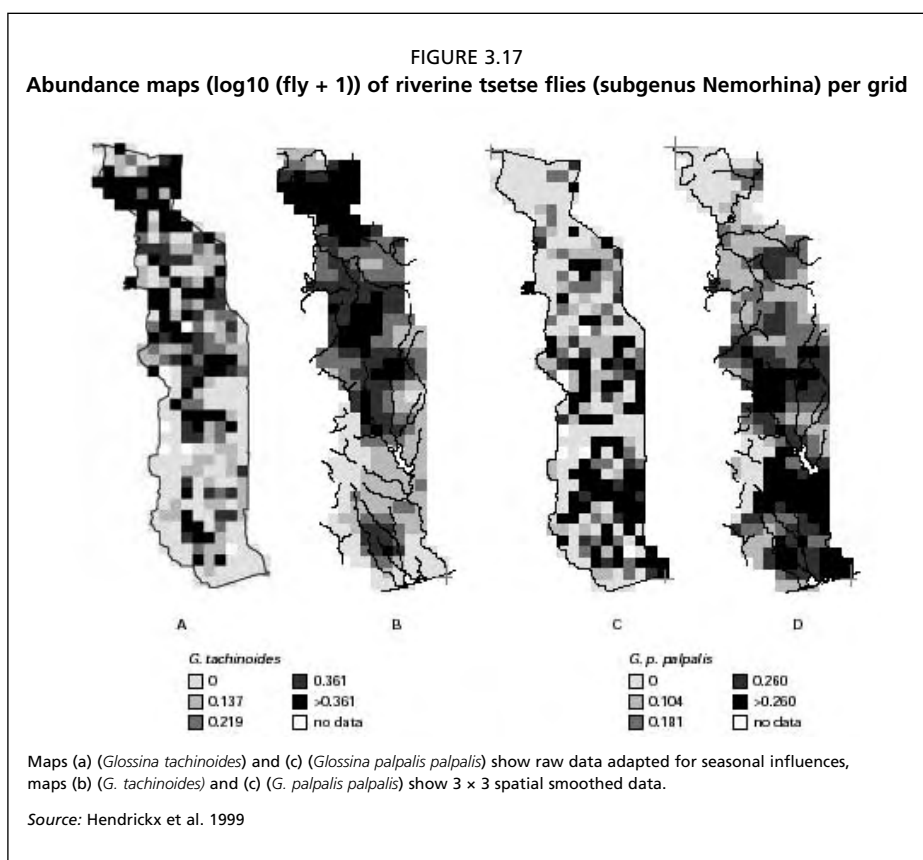

south. Seasonal clusters were obtained after hierarchical clustering of a series of remotely-sensed and ground-measured ecoclimatical variables. The authors concluded that the methodology provided an ideal transect survey that was representative for most coastal West African countries.

3.5.2. The Southern Rift Valley, Ethiopia

In the Southern Rift Valley of Ethiopia (**Figure 3.18**), an AW-IPM programme started in 1998 with the aim to create a tsetse-free zone. The programme was initiated with a baseline tsetse survey that had the objective of determining the feasibility of eradicating *G. pallidipes*, eventually from an area of 25 000 km² but starting with a block of approximately 10 000 km² (Vreysen et al. 1999).

The baseline survey was planned to define the limits of the tsetse distribution, to assess the apparent density of the tsetse populations, to confirm the degree of isolation and the number of species infesting the area. Within the block in which activities were to start (block 1), the 103 10×10 km grid squares (**Figure 3.19**) were divided amongst five field teams (**Figure 3.20**). Each team consisted of a team leader, two technicians and several assistants, and was equipped with transport, traps and full field equipment to make them fully mobile. The teams were trained in the selection of trap sites, deployment of traps

FIGURE 3.18
Satellite image of the Lake Abaya region of the Ethiopian
Southern Rift Valley



NASA

FIGURE 3.19
Map of the Southern Rift Valley survey area, Ethiopia,
with 10 x 10 km grid overlay

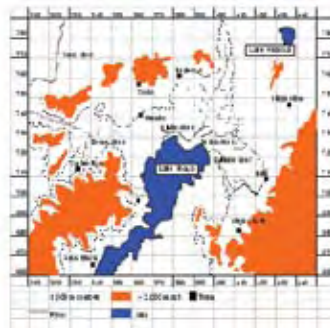

Source: Vreysen 2000

according to a standardized protocol, and fly identification and catch recording. In addition they were trained in the classification of vegetation into ten classes. The initial task for the teams was to familiarize themselves with the grids assigned to them. They studied each grid, recording the distribution of vegetation types, and checking on access routes, updating the survey maps to show new tracks.

The initial survey plan called for the deployment of at least 20 traps in each grid square for 72 hours in a three-month cycle for one complete year to observe seasonal changes. The traps were deployed in each of the available vegetation classes, and over the full range of altitudes up to more than 2000 metres above sea level (masl). The maximum altitude of trapping was adjusted by experience to ensure that the maximum trapping altitude was well above the tsetse distribution limit. The actual number of traps deployed in the grids at

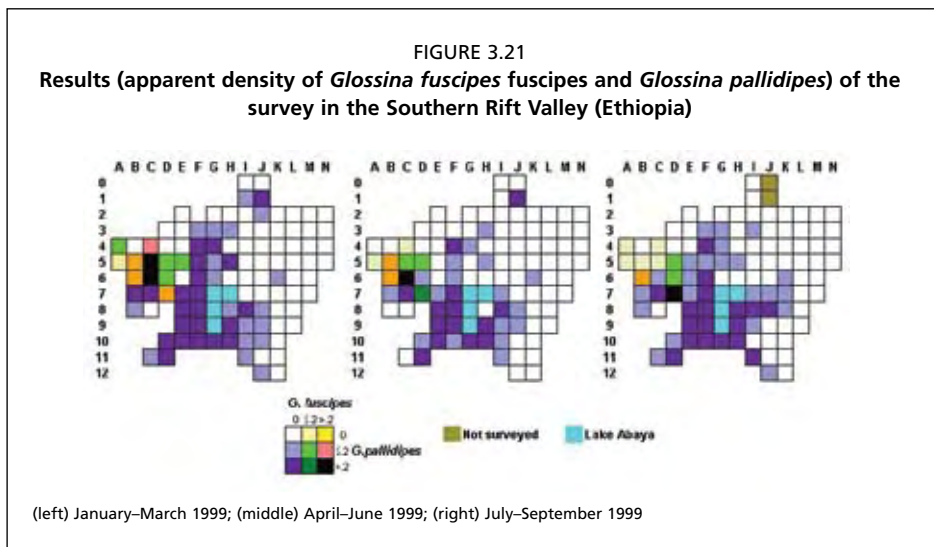
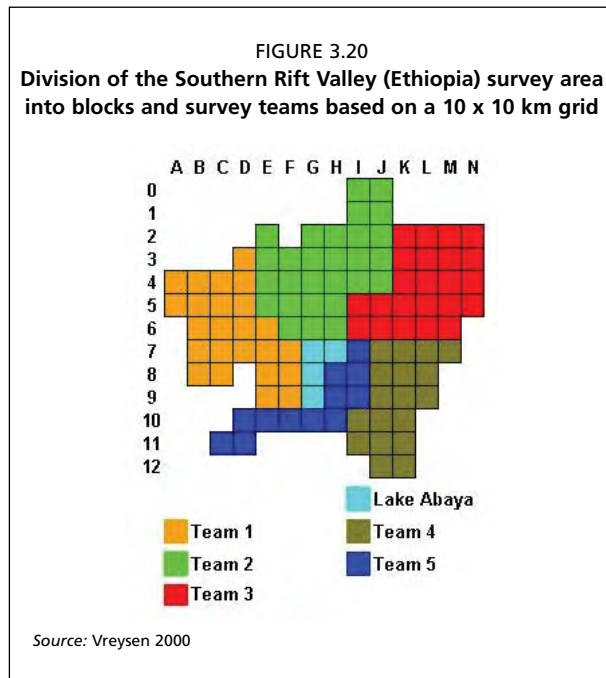

the margin of the project area varied depending on the proportion of the grid inside the project boundary.

After the first cycle of trapping the trap sites were fixed, and all trap locations identified by global positioning system (GPS) readings. Trap altitude was ascertained by digital altimeter, referred to the nearest map primary or secondary datum point (Ethiopia Department of Surveys maps 1:50 000 series).

Only a quarter of the grid squares caught tsetse on each of four surveys carried out during the year. This indicates the importance of surveying over more than one period. A single baseline survey would not have given an accurate impression of the tsetse distribution (Figure 3.21).

3.5.3. The Gambia

A third example of a large-scale, country-wide survey was the survey of The Gambia, conducted by the International Trypanotolerance Centre (ITC) and the Gambian Department of Livestock Services (DLS) in the 1980s (Rawlings et al. 1993). Although this survey was conducted without the benefits of GPS and GIS software, there are lessons to be learned from the approach taken. A grid structure was used for the country, based on 10 × 10 km UTM grid squares found on standard 1:50 000 scale maps of the country. Trapping was conducted at 1654 sites over an area of 10 000 km², using odour-baited F3 box traps deployed in each grid square for 24 hours at each site. The survey was conducted by two four-man mobile field teams who covered 80% of the area in six months. This survey did not target all areas equally, but was directed at the densest habitats that were considered most likely to be favourable to tsetse (woodlands) in each 10 × 10 km square. The suitable sites to deploy traps were identified using 1:50 000-scale aerial photographs taken in 1982 in combination with the national survey maps and finally, field verification of their suitability. Repeat surveys were carried out in grid squares from which no tsetse were initially

FIGURE 3.22
The distribution of (a) *Glossina morsitans submorsitans*, and (b) *Glossina palpalis gambiensis* in The Gambia showing the 10 × 10 km UTM grid squares in which each species was distributed

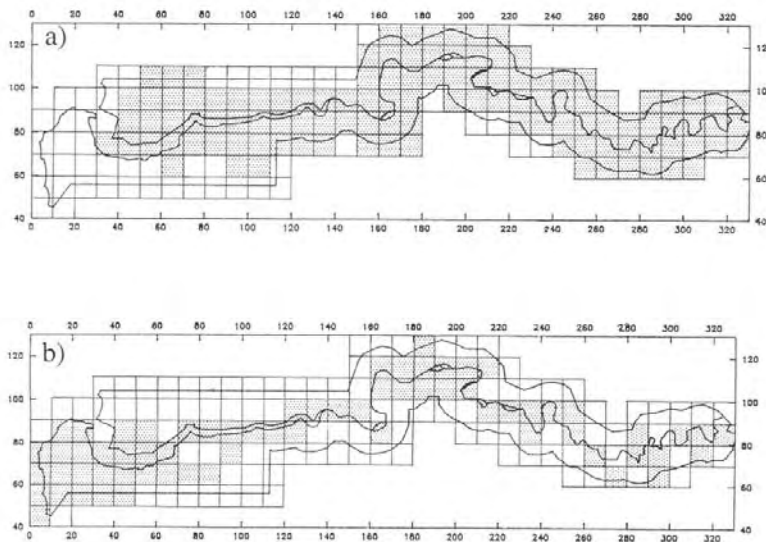

Source: Rawlings et al. 1993

FIGURE 3.23
Smoothed contours with the mean annual abundance of *Glossina morsitans submorsitans* in The Gambia based on the 1989-1990 country-wide survey

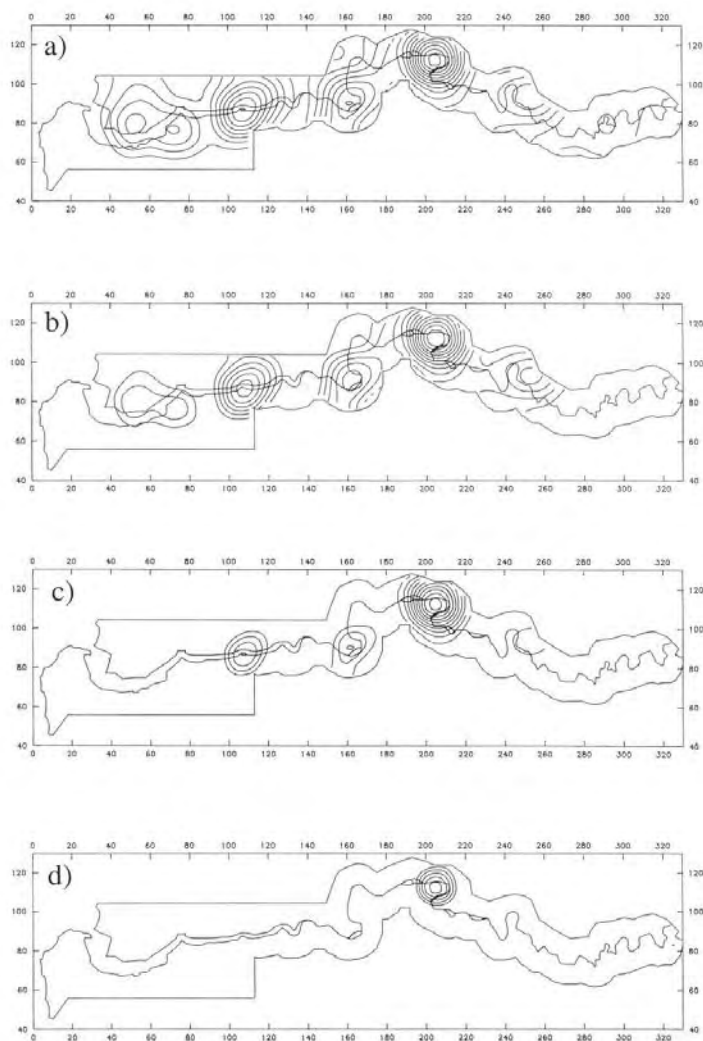

(a) areas with two or more flies/trap/day (FTD), (b) areas with FTD of five or more, (c) areas with FTD of ten or more, (d) areas with FTD of 20 or more

Source: Rawlings et al. 1993

caught. Map coordinates were taken from the same, hard copy 1:50 000 scale maps. It was subsequently possible to convert those map references into digitized UTM or decimal degrees coordinates in order to produce GIS maps of the distribution of the two tsetse species, *G. m. submorsitans* and *G. p. gambiensis*, in the country (Figure 3.22 and 3.23).

Additional information collected: Habitat type; sightings of warthogs, or warthog activity (preferred host of *G. m. submorsitans* in The Gambia). The data were stored in dbase3 files and mapped using SURFER software.

3.5.4. The Ghibe Valley, Ethiopia

This example is included in order to show how a smaller, more detailed, 1-km² grid square based survey was carried out in the Ghibe valley of Ethiopia. The survey protocol that was implemented used three odour-baited biconical traps per square kilometre, and therefore quite intensive data was acquired over a relatively small area. Due to the intensive nature of the survey, carried out by a single small team, the area of the survey could not be covered over the short period of a single period. As seasonal variations in apparent density are well known to occur, it was therefore necessary to attempt to make a seasonal adjustment for data obtained at different times of the year. This was done using data obtained from a small number of traps in a representative area for long-term monitoring over a period of 10 years prior to the survey, using a similar technique to that used in the Togo survey (see 3.5.1.).

An additional feature of the Ghibe survey was that it was complemented by other georeferenced data on households, cattle crushes, and cattle grazing areas (the latter was also done in The Gambia, leading to better epidemiological knowledge determining disease risk estimates). The Ghibe survey differed from the timing that would be expected for surveys in that it was carried out in the middle, rather than at the beginning of a small-scale (450 km²) control operation using insecticide-treated cattle, to enable a better epidemiological understanding of the events taking place rather than to plan future events. Some spatial analyses (cross-tabulations and regression analyses) of tsetse distribution and cattle grazing areas were carried out.

3.6. EQUIPMENT AND MATERIALS REQUIRED

3.6.1. Materials/equipment

The equipment necessary for the trap assistants is minimal:

- some traps and screens (about 10% of the total distributed) to replace those that may be destroyed or stolen;
- some monitoring traps and their accessories;
- books and pencils to note all observations and the results of monitoring (see monitoring);
- material for the monitoring: containers, alcohol for preserving samples, etc., and
- accessories such as a machete, hammer, string, etc.

Traps — Depending upon the design of trap decided upon, they may be obtained by an existing commercial supplier, e.g. Vestergaard-Frandsen, contracted to commercial tailors/manufacturers who are provided with a design, and preferably a sample, or by local tailors contracted to make the traps under project supervision. As referred to earlier, it is preferable to have the traps made by a commercial supplier in order to ensure a standard quality, although this may be more expensive. Furthermore, if local tailors/manufacturers are used

it is advisable to provide them with suitable cloth from a good supplier in order to ensure that it meets the required specifications.

Odour attractants — Deciding upon which odour attractants to use depends upon the species of tsetse present and which attractants are available that are effective for those species (**Tables 3.2 to 3.5 and 3.1.4**) sufficient number of standard dispensers dispensing at suitable and approximately known standard rates will be needed; some of these, for example for cow urine or acetone do not have very precise specifications and can usually be obtained cheaply locally. If synthetic phenol-based attractants are to be used these can be either obtained ready prepared, or put into sachets locally. If they are to be processed locally a roll of polythene tubing of a suitable thickness will be required and a machine for heat-sealing the sachet. It may be sufficient to use simple attractants, such as acetone and cow urine that may both be obtained locally, although purchasing large quantities of acetone can be difficult due to its flammability and restrictions on its purchase related to drug processing. It is therefore advisable to source all these items a sufficient time in advance. Cow urine functions best when it is at least three weeks old and should therefore be collected and stored before it is needed.

Satellite images — Cost and availability depend upon the resolution required, but they are becoming more readily available and affordable: United States Geological Survey (USGS), National Aeronautics and Space Administration (NASA), the FAO, and the European Union.

- **LandSat TM:** <https://zulu.ssc.nasa.gov/mrsid/> From the US Government NASA LandSat 5, LandSat 7 satellites;
- **Quickbird:** <http://digitalglobe.com/>;
- **SPOT vegetation satellite:** <http://www.vgt.vito.be> From the European satellite image processing and archiving centre, Belgium, providing free access to the vegetation image catalogue of data from the SPOT 4 and SPOT 5 satellites.
- **National Oceanic and Atmospheric Administration (NOAA) Advanced Very High Resolution Radiometer (AVHRR)** meteorological satellite data: <http://www.gis.ssd.nesdis.noaa.gov/>

Global positioning system (GPS) instruments — It is important to determine what coordinate system is to be used to georeference data and set all GPS instruments to the same system, using the same datum that is appropriate for the location of the survey. Coordinate data can/should be stored in the instruments and downloaded using the appropriate software to avoid unnecessary data entry that is often accompanied by data entry errors and the consequent need for time-consuming data-entry verification. There are a limited number of manufacturers of GPS instruments (Garmin, Magellan, Trimble) and links to those manufacturers are given in Annex 4.

Vehicles — Appropriate numbers of suitable (4WD) vehicles capable of transporting traps, people and smelly attractants; motorbikes – may sometimes be more suitable for

checking traps, although not necessarily for trap deployment, in rough terrain or in wet conditions.

Computers — Sufficient capacity and speed to handle large data sets and memory and speed consuming software for GIS. Most modern computers now meet the necessary specifications.

Software — Standard software: e.g. Microsoft Word®, Access®, Excel®, plus specialised GIS software, e.g. IDRISI or ArcView® / ArcGIS®. ArcView® or its replacement, ArcGIS®, is the standard software used for GIS whilst Microsoft Access® is widely used for data storage, analysis and reporting and is compatible with the GIS software.

A high-resolution colour printer, capable of printing A3 size is required for printing maps.

References

- Barclay, H.J., Hargrove, J.W., Clift, A. & Meats, A.** 2005. Procedures for declaring pest free status, pp. 363–386. *In* Dyck, V.A., Hendrichs, J. and Robinson, A.S., eds. *Sterile insect technique. Principles and practice in area-wide integrated pest management*. Springer, Dordrecht, The Netherlands.
- Barclay, H.J., Clift, A., Hargrove, J.W., Luckins, A.G., Feldmann, U., Geiger, R. & Vreysen, M.J.B.**, *Guidelines for declaring areas free of tsetse flies and tsetse-transmitted trypanosomiasis*. Programme Against African Trypanosomiasis Technical and Scientific Series. Food and Agriculture Organization of the United Nations, Rome, Italy (submitted).
- Baylis, M., & Nambiro, C.O.** 1993. *The responses of Glossina pallidipes and G. longipennis (Diptera: Glossinidae) to odour-baited traps and targes at Galana Ranch, south-eastern Kenya*. Bulletin of Entomological Research 83: 145–151.
- Brightwell, R., Dransfield, R.D., Kyorku, C., Golder, T.K., Tarimo, S.A. & Mungai, D.** 1987. *A new trap for Glossina pallidipes*. Tropical Pest Management 33: 151–189.
- Brightwell, R., Dransfield, R.D. & Kyorku, C.** 1991. *Development of a low-cost tsetse trap and odour baits for Glossina pallidipes and G. longipennis in Kenya*. Medical and Veterinary Entomology 5: 153–164.
- Buxton, P.A.** 1955. *The natural history of tsetse flies*. H.K. Lewis and C. Ltd. London, UK.
- Cecchi, G. & Mattioli, R.C.** 2007. *The role of FAO GeoNetwork in a multinational development programme: the case of the Programme Against African Trypanosomiasis*. OSGeo Journal 2: 20–24. http://www.osgeo.org/files/journal/v2/en-us/final_pdfs/OSGeoJournal_vol2_FAO_geonet.pdf
- Cecchi, G., Mattioli, R.C., Slingenbergh, J., de la Rocque, S. & Feldmann, U.** 2008. *Standardizing land cover mapping for tsetse and trypanosomiasis decision making*. Programme Against African Trypanosomiasis Technical and Scientific Series 8. Food and Agriculture Organization of the United Nations, Rome, Italy. <http://www.fao.org/docrep/010/i0215e/i0215e00.htm>.
- Cecchi, G., Mattioli, R.C., Slingenbergh, J., de la Rocque, S.** *Land cover and tsetse fly distributions in sub-Saharan Africa*. Medical and Veterinary Entomology. <http://dx.doi.org/10.1111/j.1365-2915.2008.00747.x> (in press).
- Challier, A., & Laveissière, C.** 1973. *Un nouveau piège pour la capture des glossines (Glossina: Diptera, Muscidae). Description et essais sur le terrain*. Cahiers ORSTOM Série Entomologie Médicale et Parasitologie 11: 251–262.
- Challier, A., Eyraud, M., Lafaye, A. & Laveissière, C.** 1977. *Amélioration du rendement du piège biconique pour glossines (Diptera, Glossinidae), par l'emploi d'un cône inférieur bleu*. Cahiers ORSTOM Série Entomologie Médicale et Parasitologie 15: 283–286.
- Cox, J.St.H.** 2007. The role of geographic information systems and spatial analysis in area-wide vector control programmes, pp. 199–210. *In* Vreysen, M.J.B., Robinson, A.S. & Hendrichs, J.,

- eds. *Area-wide control of insect pests. From research to field implementation*. Springer, Dordrecht, The Netherlands.
- Cox, J.St.H. & Vreysen, M.J.B.** 2005. Use of geographic information systems and spatial analysis in area-wide integrated pest management programmes that integrate the sterile insect technique, pp. 453-477. In Dyck, V.A., Hendrichs, J. & Robinson, A.S., eds. *Sterile insect technique. Principles and practice in area-wide integrated pest management*. Springer, Dordrecht, The Netherlands.
- Crump, A.J. & Brady, J.** 1979. *Circadian activity patterns in three species of tsetse: Glossina palpalis, austeni and morsitans*. *Physiological Entomology* 4: 311-318.
- Cuisance, D.** 2000. *Cours international sur les trypanosomoses Africaines*. CIRAD-EMVT, Montpellier Cedex 5, France.
- Desquesnes, M. & Davila, A.M.R.** 2002. *Applications of PCR-based tools for detection and identification of animal trypanosomes: a review and perspectives*. *Veterinary Parasitology* 109: 213-231.
- Desquesnes, M. & Dia, M.L.** 2004. *Mechanical transmission of Trypanosoma vivax in cattle by the African tabanid Atylotus fuscipes*. *Veterinary Parasitology* 119: 9-19.
- Dujardin, J.P., Bermudez, H., Casini, C., Schofield, C.J. & Tibayrenc, M.** 1997. *Metric differences between silvatic and domestic Triatoma infestans (Heteroptera: Reduviidae) in Bolivia*. *Journal of Medical Entomology* 34: 544-551.
- Dyck, V.A., Reyes Flores, J., Vreysen, M.J.B., Regidor-Fernandez, E., Teruya, T., Barnes, B., Gomez Riera, P., Lindquist, D. & Loosjes, M.** 2005. Management of area-wide integrated pest management programmes that integrate the sterile insect technique, pp. 525-545. In Dyck, V.A., Hendrichs, J. & Robinson, A.S., eds. *Sterile insect technique. Principles and practice in area-wide integrated pest management*. Springer, Dordrecht, The Netherlands.
- Fillidier, J. & Mérot, P.** 1989. *Etude de l'attractivité de solutions isolées par fractionnement de l'urine de bovin Baoulé pour Glossina tachinoides Westwood, 1850 au Burkina Faso*. *Revue d'Élevage de Médecine Vétérinaire des Pays tropicaux* 42: 453-455.
- Flint, S.** 1985. *A comparison of various traps for Glossina spp. (Glossinidae) and other Diptera*. *Bulletin of Entomological Research* 75: 529-534.
- Food and Agriculture Organization (FAO).** 1982a. *Training manual for tsetse control personnel. Volume 1. Tsetse biology, systematics and distribution; techniques*. FAO, Rome, Italy.
- Food and Agriculture Organization (FAO).** 1982b. *Training manual for tsetse control personnel. Volume 2. Ecology and behaviour of tsetse*. FAO, Rome, Italy.
- Food and Agriculture Organization (FAO).** 1992. *Training manual for tsetse control personnel. Volume 4. Use of attractive devices for tsetse survey and control*. FAO, Rome, Italy.
- Food and Agriculture Organization (FAO).** 1993. *Training manual for tsetse control personnel. Volume 5. Insecticides for tsetse and trypanosomiasis control using attractive bait techniques*. FAO, Rome, Italy.
- Ford, J. & Katondo, K.M.** 1977. *Maps of tsetse fly (Glossina) distribution in Africa, 1973, according to subgeneric groups on scale of 1:5,000,000*. *Bulletin of Animal Health and Production in Africa* 25: 187-193.
- Gooding, R.H. & Krafusur, E.S.** 2005. *Tsetse genetics: contributions to biology, systematics, and control of tsetse flies*. *Annual Review of Entomology* 50: 101-123.

- Gouteux, J.P.** 1987. *Une nouvelle glossine du Congo: Glossina (Austenina) frezili sp. Nov. (Diptera: Glossinidae)*. Tropical Medicine and Parasitology 38: 97–100.
- Gouteux, J.P.** 1991. La lutte par piégeage contre *Glossina fuscipes fuscipes* pour la protection d'élevage en République Centrafricaine. 2. Caractéristiques du piège bipyramidal. Revue d'Élevage et de Médecine Vétérinaire des Pays tropicaux 44: 295–299.
- Gouteux, J.P. & Lancien, J.** 1986. *Le piège pyramidal à tsé-tsé (Diptera: Glossinidae) pour la capture et la lutte. Essais comparatifs et description de nouveau piège*. Tropical Medicine and Parasitology 37: 61–66.
- Gouteux, J.P., Cuisance, D., Demba, D., N'Dokoue, F. & Le Gall, F.** 1991. *La lutte par piégeage contre Glossina fuscipes fuscipes pour la protection d'élevage en République Centrafricaine. 1. Mise au point d'un piège adapté à un milieu d'éleveurs semi-nomades*. Revue d'Élevage et de Médecine Vétérinaire des Pays tropicaux 44: 287–294.
- Green, C. & Flint, S.** 1986. *An analysis of colour effects in the performance of the F2 trap against Glossina pallidipes Austen and G. morsitans morsitans Westwood (Diptera: Glossinidae) in Zimbabwe*. Bulletin of Entomological Research 76: 409–418.
- Hall, M.J.R. & Wall, R.** 2004. Biting flies: their role in the mechanical transmission of trypanosomes to livestock and methods for their control, pp. 583–594. In Maudlin, I., Holmes, P.H. & Miles, M.A., eds. The trypanosomiasis. CABI Publishing, Oxfordshire, UK.
- Hall, D.R., Beevor, P.S., Cork, A., Nesbitt, B.F. & Vale, G.A.** 1994. *1-Octen-3-ol: a potent olfactory stimulant and attractant for tsetse isolated from cattle odours*. Insect Science and its Applications 5: 335–339.
- Hargrove, J.W. & Langley, P.A.** 1990. *Sterilising tsetse in the field — a successful trial*. Bulletin of Entomological Research 80: 397–403.
- Hargrove, J.W. & Brady, J.** 1992. *Activity rhythms of tsetse flies (Glossina spp.) (Diptera: Glossinidae) at low and high temperatures in nature*. Bulletin of Entomological Research 82: 321–326.
- Hendrichs, J., Robinson, A.S., Kenmore, P. & Vreysen, M.J.B.** 2007. Area-wide integrated pest management: principles, practice and prospects, pp. 3–33. In Vreysen, M.J.B., Robinson, A.S., & Hendrichs, J., eds. *Area-wide control of insect pests. From research to field implementation*. Springer, Dordrecht, The Netherlands.
- Hendrichs, J., Vreysen, M.J.B., Enkerlin, W.R. & Cayol, J.P.** 2005. Strategic options in using sterile insects for area-wide integrated pest management, pp. 563–600. In Dyck, V.A., Hendrichs, J. & Robinson, A.S., eds. *Sterile insect technique. Principles and practice in area-wide integrated pest management*. Springer, Dordrecht, The Netherlands.
- Hendrickx, G., de la Rocque, S. & Mattioli, R.C.** 2004. *Long-term tsetse and trypanosomiasis management options in West Africa. Programme Against African Trypanosomiasis*. Technical and Scientific Series 6, Food and Agriculture Organization of the United Nations, Rome, Italy.
- Hendrickx, G., Napala, A., Dao, B., Batawui, D., de Deken, R., Vermeilen, A. & Slingenbergh, J.H.W.** 1999. *A systematic approach to area-wide tsetse distribution and abundance maps*. Bulletin of Entomological Research 89: 231–244.
- International Atomic Energy Agency (IAEA).** 2003. *Improved attractants for enhancing tsetse fly suppression*. Final report of a coordinated research project 1996–2002. IAEA-TEC-DOC-1373 FAO/IAEA. IAEA, Vienna, Austria.

- Itard, J.** 1966. Cycle de l'oogenèse chez les femelles de *Glossina tachinoides* West. et détermination de l'âge physiologique. *Revue d'Elevage et de Médecine Vétérinaire des Pays tropicaux* 19: 331–350.
- Ito, Y.** 1989. Population assessment, pp. 175–183. In Robinson, A.S., & Hooper, G., eds. *World crop pests 3B. Fruit flies: their biology, natural enemies and control*. Elsevier, New York, NY, USA.
- Jamonneau, V., Ravel, S., Koffi, M., Zeze, D., Kaba, D., N'Dri, L., Coulibaly, B., Cuny, G. & Solano, P.** 2004. Mixed trypanosome infections in tsetse and pigs and their epidemiological significance in a sleeping sickness focus in Côte d'Ivoire. *Parasitology* 129: 693–702.
- Jordan, A.M.** 1993. Tsetse flies (Glossinidae), pp. 333–388. In Lane, R.P. & Crosskey, R.W., eds. *Medical insects and arachnids*. Chapman & Hall, London, UK.
- Kappmeier, K.** 2000. A newly developed odour-baited "H trap" for the live collection of *Glossina brevipalpis* and *Glossina austeni* (Diptera: Glossinidae) in South Africa. *Onderstepoort Journal of Veterinary Research* 67: 15–26.
- Klassen, W.** 2005. Area-wide integrated pest management and the sterile insect technique, pp. 39–68. In Dyck, V.A., Hendrichs, J., and Robinson, A.S., eds. *Sterile insect technique. Principles and practice in area-wide integrated pest management*. Springer, Dordrecht, The Netherlands.
- Krafsur, E.S.** 2003. Tsetse fly population genetics: an indirect approach to dispersal. *Trends in Parasitology* 19: 162–166.
- Kuzoe, F.A.S. & Schofield, C.J.** 2005. *Strategic review of traps and targets for tsetse and African trypanosomiasis control*. WHO/TDR, Geneva, Switzerland.
- Kyorku, C. & Brady, J.** 1994. A free-running bimodal circadian rhythm in the tsetse fly *Glossina longipennis*. *Journal of Insect Physiology* 40: 63–67.
- Kyorku, C., Brightwell, R. & Dransfield, R.D.** 1990. Traps and odour baits for the tsetse fly, *Glossina longipennis* (Diptera: Glossinidae). *Bulletin of Entomological Research* 80: 405–416.
- Lancien, J.** 1981. Description du piège monoconique utilisé pour l'élimination des glossines en République Populaire du Congo. *Cahiers ORSTOM Série Entomologie Médicale et Parasitologie* 19: 235–238.
- Lancien, J. & Gouteux, J.P.** 1987. Le piège pyramidal à mouche tsé-tsé (Diptera: Glossinidae). *Afrique Médicale* 26: 647–652.
- Laveissière, C. & Grébaud, P.** 1990. Recherches sur les pièges à Glossines (Diptera: Glossinidae). Mise au point d'un modèle économique: le piège "Vavoua". *Tropical Medicine and Parasitology* 41: 185–192.
- Leak, S.G.A.** 1998. *Tsetse biology and ecology: their role in the epidemiology and control of trypanosomosis*. CABI International, Oxford, UK.
- Leak, S.G.A., Ceesay, M.L., Fofana, D. & Münstermann, S.** 2004. Prevaling diseases and control options in the Kombos districts of The Gambia. Proceedings of a conference of PRO-CORDEL, November 2003, Banjul, The Gambia. ITC, The Gambia.
- Leak, S.G.A., Mulatu, W., Rowlands, G.J. & d'Ieteren, G.D.M.** 1995. A trial of cypermethrin pour-on insecticide to control *Glossina pallidipes*, *G. f. fuscipes* and *G. morsitans submorsitans* in the Ghibe valley, Ethiopia. *Bulletin of Entomological Research* 85: 241–251.

- Lefrançois T., Solano, P., de la Rocque, S., Bengaly, Z., Reifenberg, J.M., Kabore, I. & Cuisance, D.** 1998. *New epidemiological features on animal trypanosomiasis by molecular analysis in the pastoral zone of Sédéradougou, Burkina Faso*. *Molecular Ecology* 7: 897–904.
- Machado, A. de Barros.** 1954. *Révision systématique des glossines du groupe palpalis (Diptera)*. Publication of Museo do Dundo Companhia De Diamantes de Angola (Diamang) No. 22.
- Machado, A. de Barros.** 1959. *Nouvelles contributions à l'étude systématique et biogéographique des glossines (Diptera)*. Publication of Museo do Dundo Companhia De Diamantes de Angola (Diamang) No. 46.
- Maudlin, I., Holmes, P.H. & Miles, M.A., eds.** 2004. *The trypanosomiasis*. CAB International, Cromwell Press, UK.
- Marquez, J.G., Vreysen, M.J.B., Robinson, A.S., Bado, S. & Krafur, E.S.** 2004. *Mitochondrial diversity analysis of Glossina palpalis gambiense from Mali and Senegal*. *Medical and Veterinary Entomology* 18: 288–295.
- Mihok, S.** 2002. *The development of a multipurpose trap (the NZI) for tsetse and other biting flies*. *Bulletin of Entomological Research* 92: 385–403.
- Moloo, S.K.** 1985. *Distribution of Glossina species in Africa*. *Acta Tropica* 42: 275–281.
- Moloo, S.K.** 1993. *The distribution of Glossina species in Africa and their natural hosts*. *Insect Science and its Applications* 14: 511–527.
- Mulligan, H.W., ed.** 1970. *The African trypanosomiasis*. George Allan and Unwin. London, UK.
- Ndegwa, P.N. & Mihok, S.** 1999. *Development of odour-baited traps for Glossina swynnertoni (Diptera: Glossinidae)*. *Bulletin of Entomological Research* 89: 255–261.
- Newstead, R., Evans, A.M. & Potts, W.H.** 1924. *Guide to the study of tsetse-flies*. *Memoirs Liverpool School of Tropical Medicine* 1: 1–382.
- Njiokou, F., Simo, G., Mbida Mbida, A., Truc, P., Cuny, G., & Herder, S.** 2004. *A study of host preferences in tsetse flies using a modified PCR-heteroduplex technique*. *Acta Tropica* 91: 117–120.
- Okoth, J.O.** 1991. *Description of a mono-screen trap for Glossina fuscipes fuscipes Newstead in Uganda*. *Annals of Tropical Medicine and Parasitology* 85: 309–314.
- Owaga, M.L.A.** 1985. *Observations on the efficacy of buffalo urine as a potent olfactory attractant for Glossina pallidipes Austen*. *Insect Science and its Applications* 6: 561–566.
- Paling, R.W., Moloo, S.K. & Leak, S.G.A.** 1987. *Epidemiology of animal trypanosomiasis on a cattle ranch in Kilifi, Kenya*. *Acta Tropica* 44: 67–82.
- Patterson, J.S. & Schofield, C.J.** 2005. *Preliminary study of wing morphometry in relation to tsetse population genetics*. *South African Journal of Science* 101: 1–3.
- Potts, W.H.** 1973. *Glossinidae: tsetse flies*. In Smith, K.G.V., ed. *Insects and other arthropods of medical importance*. British Museum (Natural History), London, UK.
- Programme Against African Trypanosomiasis (PAAT).** 2002. *Workshop on PAAT-PATTEC harmonisation, 2–3 May 2002, Rome, Italy*. FAO, Rome, Italy.
- Rawlings, P., Ceasay, M.L., Wachter, T. & Snow, W.** 1993. *The distribution of the tsetse flies Glossina morsitans submorsitans and G. palpalis gambiense (Diptera, Glossinidae) in The Gambia*. *Bulletin of Entomological Research* 83: 625–632.
- Rogers, D.J. & Randolph, S.E.** 1991. *Mortality rates and population density of tsetse flies correlated with satellite imagery*. *Nature* 351: 739–741.

- Rohlf, F.J. & Marcus, L.F.** 1993. *A revolution in morphometrics*. Trends in Ecology and Evolution 8: 129–132.
- Solano, P., de la Rocque, S., Cuisance, D., Geoffroy, B., de Meeüs, T., Cuny, G. & Duvallet, G.** 1999. *Intraspecific variability in natural populations of Glossina palpalis gambi-ensis from West Africa, revealed by genetic and morphometric analyses*. Medical and Veterinary Entomology 13: 401–407.
- Solano, P., de la Rocque, S., de Meeüs, T., Cuny, G., Duvallet, G. & Cuisance, D.** 2000. *Microsatellite DNA markers reveal genetic differentiation among populations of Glossina palpalis gambi-ensis collected in the agro-pastoral zone of Sédéradougou, Burkina Faso*. Insect Molecular Biology 9: 433–439.
- Späth, J.** 1997. *Natural host odours as possible attractants for Glossina tachinoides and G. longipalpis (Diptera: Glossinidae)*. Acta Tropica 68: 149–158.
- Thrusfield, M.V.** 1995. *Veterinary epidemiology*. 2nd edition. Blackwell Publishing, London, UK.
- Torr, S.J., Parker, A.G. & Leigh-Browne, G.** 1989. *The responses of Glossina pallidipes Austen (Diptera: Glossinidae) to odour baited traps and targets in southern Somalia*. Bulletin of Entomological Research 79: 99–108.
- Turner, D.A. & Makishe, F.** 1985. *The distribution of Glossina austeni in Zanzibar*, pp. 263–271. In Proceedings: 18th meeting of the International Scientific Council for Trypanosomiasis Research and Control, 4–9 March 1985, Harare, Zimbabwe. OAU/IBAR, Nairobi, Kenya.
- Vale, G.A.** 1971. *Artificial refuges for tsetse flies (Glossina spp.)*. Bulletin of Entomological Research 61: 331–350.
- Vale, G.A.** 1980. *Field studies of the responses of tsetse flies (Glossinidae) and other Diptera to carbon dioxide, acetone and other chemicals*. Bulletin of Entomological Research, 70: 563–570.
- Vale, G.A.** 1998. *Responses of tsetse flies (Diptera: Glossinidae) to vegetation in Zimbabwe: implications for population distribution and bait siting*. Bulletin of Entomological Research 88: Supplement, S7–S59.
- Vale, G.A. & Hargrove, J.W.** 1979. *A method for studying the efficiency of traps for tsetse flies (Diptera: Glossinidae) and other insects*. Bulletin of Entomological Research 69: 183–193.
- Vale, G.A. & Hall, D.R.** 1985. *The use of 1-octen-3-ol and carbon dioxide to improve baits for tsetse flies Glossina spp. (Diptera: Glossinidae)*. Bulletin of Entomological Research 75: 219–231.
- Vreysen, M.J.B.** 2000. *Southern Rift Valley tsetse eradication programme — an analysis of the entomological base-line data collected between October 1998 and September 1999*. Report to the IAEA. IAEA, Vienna, Austria.
- Vreysen, M.J.B.** 2005. *Monitoring sterile and wild insects in area-wide integrated pest management programmes*, pp. 325–361. In Dyck, V.A., Hendrichs, J. & Robinson, A.S., eds. *Sterile insect technique. Principles and practice in area-wide integrated pest management*. Springer, Dordrecht, The Netherlands.
- Vreysen, M.J.B., Khamis, I.S. & Van der Vloedt, A.M.V.** 1996. *Evaluation of sticky panels to monitor populations of Glossina austeni (Diptera: Glossinidae) on Unguja Island of Zanzibar*. Bulletin of Entomological Research 86: 289–296.

- Vreysen, M.J.B., Zhu, Z-R. & Saleh, K.M.** 1998. *Field responses of Glossina austeni to sticky panels on Unguja island of Zanzibar*. Medical and Veterinary Entomology 12: 407–416.
- Vreysen, M.J.B., Mebrate, A., Menjeta, M., Banacha, B., Woldeyes, G., Musie, K., Bekele, K. & Aboset, G.** 1999. The distribution and relative abundance of tsetse flies in the Southern Rift Valley of Ethiopia. Preliminary survey results, pp. 202–213. *In Proceedings: 25th meeting of the International Scientific Council for Trypanosomiasis Research and Control, 27 September–1 October 1999, Mombasa, Kenya*. OAU/IBAR, Nairobi, Kenya.
- Vreysen, M.J.B., Gerardo-Abaya, J. & Cayol, J.P.** 2007. Lessons from area-wide integrated pest management (AW-IPM) programmes with an SIT component: An FAO/IAEA perspective, pp. 723–744. *In Vreysen, M.J.B., Robinson, A.S. & Hendrichs, J., eds. Area-wide control of insect pests. From research to field implementation*. Springer, Dordrecht, The Netherlands.
- Weir, B.S. & Cockerham, C.C.** 1984. *Estimating F-statistics for the analysis of population structure*. Evolution 38: 1358–1370.
- Williams, B., Dransfield, R. & Brightwell, R.** 1990. *Monitoring tsetse populations. 1. The intrinsic variability of trap catches of Glossina pallidipes at Nguruman, Kenya*. Medical and Veterinary Entomology 4: 167–179.
- Wint, W.** 2001. *Kilometre resolution tsetse fly distribution maps for the Lake Victoria Basin and West Africa*. FAO/IAEA Joint Division, Insect Pest Control Section, IAEA, Vienna, Austria, December 2001.
- Wint, W.** 2002. *Environmental predictors of tsetse distributions / integrated control of pathogenic trypanosomes and their vectors*. Newsletter Number 4.
- Wint, W.** 2003. *Tsetse distribution data, May 2003*. Data CD prepared by Environmental Research Group Oxford Ltd for the Insect Pest Control Section, Joint FAO/IAEA Division of Nuclear Techniques in Food and Agriculture, International Atomic Energy Agency.
- World Health Organization (WHO).** 1997. *Manual for sleeping sickness control*. WHO, Geneva, Switzerland.

Annex 1

Links to web pages

Note that web sites are ephemeral and although available at the time of writing, their continued availability cannot be assured.

http://www.nri.org/tsetse/FAQ/biconical.html	Trap designs
http://www.nri.org/tsetse/FAQ/pyramid.html	Trap designs
http://www.nri.org/tsetse/FAQ/pyramids.html	Trap designs
http://www.nri.org/tsetse/FAQ/epsilon.html	Trap designs
http://www.nri.org/tsetse/FAQ/nzi.html	Trap designs
http://www.nri.org/tsetse/FAQ/ngu.html	Trap designs
http://www.nri.org/tsetse/FAQ/htrap.htm	Trap designs
http://www.sleeping-sickness.com	Trap designs and trapping
http://www.vestergaard-frandsen.com	Commercial supply of traps and trap materials
http://www.sleeping-sickness.com/index.htm	IRD: La Maladie du Sommeil; Resource site for manuals and other information for control of tsetse flies and sleeping sickness.
www.fao.org/paat/html/home.htm	PAAT
http://www.fao.org/ag/againfo/programmes/en/paat/documents/manuals/vol4.html	FAO Tsetse Training Manual Vol. 4.
http://www.fao.org/ag/againfo/programmes/en/paat/documents/manuals/vol5.html	FAO Tsetse Training Manual Vol. 5.
http://www.navtechgps.com/pdf/Garmin_PaperMaps.pdf	Garmin manual on use of maps
www.nri.org/tsetse/Plan	Models for planning tsetse operations
http://www.vgt.vito.be/	Vegetation satellite images
http://cicci2002.dynamicweb.dk/Files/Filer/Textiles_Tsetse_fly_fabric.pdf	
www.mpl.ird.fr/entomo_medicale/resumeTSEuk.html	IRD (formerly ORSTOM) site for the CD-Rom for identification of tsetse (Les Glossines ou Mouche tsetse)

http://www.mpl.ird.fr/morphometrics	Providing principles of morphometrics and providing free software for data analysis
http://igskmncnwb015.cr.usgs.gov/adds	Africa Data Dissemination Service
http://www.tanglefoot.com	Supply of sticky glue for traps
http://www.clarklabs.org	RISI GIS software
http://www.esri.com/index.html	ESRI — ArcView GIS software
http://www.ilri.cgiar.org/gis	ILRI GIS data, and maps
http://ergodd.zoo.ox.ac.uk	Predictive mapping
http://www.maproom.psu.edu/dcw	Digital charts of the World (GIS base maps)
http://www.fcc.gov/mb/audio/bickel/DDDMSS-decimal.html	Coordinate conversion
http://www.directionsmag.com/latlong.php	Coordinate conversion
http://www.geology.enr.state.nc.us/gis/latlon.html	Coordinate conversion
http://www.who.int/docstore/water_sanitation_health/vectcontrol/begin.htm#Contents	WHO Vector control manual
http://www.novalynx.com/110-ws-16.html ; http://fischer-barometer.de/english	Weather stations
http://www.esri.com/software/arcexplorer/index.html	ArcExplorer free GIS software

Annex 2

Glossary

**Area-Wide
(Eradication/Control)**

Area-wide eradication or control refers to eradication or control of a total, discrete, circumscribed population (in this case of tsetse flies). It does not necessarily have to be a large area, but could be for example, a small 5 km × 5 km island in Lake Victoria provided there was no regular movement of tsetse from that island to another nearby area of infestation. In contrast it could be a very large, regional infestation of tsetse such as that targeted by RTTCP, provided it has distinct limits of distribution and all of that area of distribution is included in the area-wide approach.

Datum

A point, line, or surface used as a reference, in surveying, mapping, or geology

Deme

A local, usually stable population of interbreeding organisms of the same kind or species

Ecotone

A transitional zone between two communities containing the characteristic species of each

Eradication

The elimination of a (tsetse) species from a given area — it does not mean global elimination (extinction).

Suppression

Reducing the numbers of a tsetse population in a given area so that the density falls below an unspecified level, resulting in reduced disease transmission to humans or livestock. The objective may be to reduce the population to a level at which SIT becomes feasible rather than for disease control.

Shapefile

A popular file format for GIS layers. The shapefile specification requires that each shapefile be composed of only one type of vector layer: either point or line or area. A “shapefile” is not a single computer file but rather a collection of at least three actual files with nearly identical names: the base name of all three is the same whereas the extensions are different. So, for example a GIS layer of traps would be composed of three files- *traps.shp*, *traps.shx* and *traps.dbf*. In addition, the coordinate system of a shapefile can be specified using an additional file with the **.prj* extension.

Vector layer

One of the two classifications of GIS data (see raster). A vector layer is specified by a collection of precise coordinates for each feature within the layer. If the features are points, then each point is represented by exactly one pair of coordinates. For line features, each line is represented by an ordered list of coordinate pairs, one pair for each node (or "corner") of the line. A polygon or area feature is similar to a line feature with one coordinate pair for each vertex of the polygon, but in addition, the first pair of coordinates and the last pair are exactly the same point.

Vector layers will typically be linked to a table of attribute data, and each feature in the layer can have entries for all the attributes

Raster layer

A raster is a rigid rectangular matrix of points (called "pixels"), where each point contains a single numeric value. The distance between the points or pixels determines the resolution of the raster. The numeric value can represent colours, elevations, vegetation types, etc. Aerial photography, satellite imagery, and elevation layers are typically supplied as raster layers. Within GIS, many mathematical calculations can be applied on a single raster, or between two or more rasters to obtain new information. For example, a raster layer of vegetation type, overlaid with a raster of elevation, and a third raster mean temperature can give a predictive map for tsetse abundance.

Cadastral layer

A vector layer of land ownership, or administrative boundaries. Often these layers are commissioned by a government mapping office, and created by a professional team of surveyors.

Topographic map

Many government mapping offices publish printed maps at a standard scale of 1:50 000 or 1:24 000. These maps usually include roads, residential areas, points of interest, streams, and contours of elevation. These maps are often scanned (with a special highly accurate scanner) and a high resolution image file created from them. They are then geo-referenced and saved in an image format known as "*geo-tiff*" for viewing in GIS. Scanned topographic maps can serve as a good background image for overlaying other GIS layers.

Annex 3

Acronyms

ADB	African Development Bank
AVHRR	Advanced Very High Resolution Radiometer
AW-IPM	Area-Wide Integrated Pest Management
CIRAD	Centre de Coopération Internationale en Recherche Agronomique pour le Développement
CIRDES	Centre International Recherche-Développement en Zone Subhumide
DAVID	Disease And Vector Integrated Database
DCW	Digital Charts of the World
DLS	Department of Livestock Services
DRC	Democratic Republic of Congo
ERGO	Ecological Research Group, Oxford
ESRI	Environmental Systems Research Institute Inc
FAO	Food and Agriculture Organization of the United Nations
FITCA	Farming in Tsetse Controlled Areas
GIS	Geographical Information System
GPS	Global Positioning System
IAEA	International Atomic Energy Agency
ICIPE	International Centre for Insect Physiology and Ecology
ILRAD	International Laboratory for Research on Animal Diseases
ILRI	International Livestock Research Institute
IRD	Institut de Recherche pour le Développement (formerly ORSTOM)
ITC	International Trypanotolerance Centre Or: Insecticide-Treated Cattle
KARI –TRC	Kenyan Agricultural Research Institute — Trypanosomiasis Research Centre
KEMRI	Kenyan Medical Research Institute
NASA	National Aeronautical and Space Agency
NOAA	National Oceanographic and Atmospheric Administration
NRI	Natural Resources Institute
PAAT	Programme Against African Trypanosomiasis
PATTEC	Pan-African Tsetse and Trypanosomiasis Eradication Campaign
PAAT-IS	Programme Against African Trypanosomiasis Information System
PCR	Polymerase Chain Reaction
PDA	Personal Digital Assistant
RS	Remote Sensing

RTTCP	Regional Tsetse and Trypanosomiasis Control Programme (southern Africa)
SARD	Sustainable Agricultural and Rural Development
SIT	Sterile Insect Technique
SPOT	Satellite Pour l'Observation de la Terre
TIRRS	Tsetse Intervention Recording and Reporting System
USGS	United States Geological Service
UTM	Universal Transverse Mercator
WGS	World Geodetic System
WHO	World Health Organization

Annex 4

Suppliers

Tsetse traps and fabrics

Vestergaard-Frandsen: <http://www.vestergaard-frandsen.com/>

GPS instruments

Garmin: <http://www.garmin.com/garmin/cms/site/us>

Magellan: <http://www.magellangps.com/>

Trimble: <http://www.trimble.com/index.aspx>

Odour attractants

Sigma Aldrich (http://www.sigmaaldrich.com/Local/SA_Splash.html), Suppliers of 3-Methylphenol and 4-Methylphenol

International Flavours & Fragrances I.F.F. (Great Britain) Ltd. (<http://www.iff.com/Internet.nsf/0/36C4E92098507FE085256C0E000C5636>) Suppliers of Octenol

Great Lakes Fine Chemicals (UK) (<http://www.excelsyn.com/>) Suppliers of 4-propylphenol or 3-isopropylphenol as substitutes for 3-propylphenol which is not easily obtained

Appropriate Applications Suppliers of 4-propylphenol or 3-isopropylphenol as substitutes for 3-propylphenol which is not easily obtained

Weather station equipment

Appropriate Applications Novalynx: <http://www.novalynx.com/110-ws-16.html>

Meteoclima: <http://fischer-barometer.de/english/>

FAO ANIMAL PRODUCTION AND HEALTH GUIDELINES

1. Collection of entomological baseline data for tsetse area-wide integrated pest management programmes, 2008 (E)

Availability: November 2008

Ar - Arabic	Multil - Multilingual
C - Chinese	* Out of print
E - English	** In preparation
F - French	^e E-publication
P - Portuguese	
R - Russian	
S - Spanish	
M - Mongolian	
B - Bahasa	

The FAO Animal Production and Health Guidelines are available through the authorized FAO Sales Agents or directly from Sales and Marketing Group, FAO, Viale delle Terme di Caracalla, 00153 Rome, Italy.

Area-wide integrated pest management (AW-IPM) entails the integration of different control tactics against an entire pest population within a circumscribed area, while given adequate attention to human health and the environment. For most insect pests including tsetse, AW-IPM results in more sustainable pest control and the concept has gained significantly in importance in the last decade.

Most of AW-IPM programmes are management intensive and technically complex, requiring an in-depth knowledge of the ecology and population dynamics of the target insect. Before embarking on a tsetse AW-IPM control programme a detailed entomological baseline data survey needs to be implemented to collect essential data on tsetse species present in the target area, their distribution, and seasonal and spatial dynamics of the population. Especially when the target area is large, the surveys need to be conducted in carefully selected sites that are representative for larger areas.

These guidelines provide, aside from some basic information on the biology of tsetse flies, guidance on the development and implementation of an entomological survey to collect essential baseline data using modern spatial tools such as geographic information systems (GIS), satellite imagery, remote sensing, land use land cover maps, the Global Position System, etc. The document also provides guidance on the use of a specifically designed database for tsetse entomological surveys in the context of an AW-IPM programme.

ISBN 978-92-5-106158-9 ISSN 1810-0708



9 789251 061589

TC/M/10535E/1/01.09/930