



GOOD HYGIENIC PRACTICES IN THE PREPARATION AND SALE OF STREET FOOD IN AFRICA

Tools for training



GOOD HYGIENIC PRACTICES IN THE PREPARATION AND SALE OF STREET FOOD IN AFRICA

Tools for training

The designations employed and the presentation of material in this information product do not imply the expression of any opinion whatsoever on the part of the Food and Agriculture Organization of the United Nations (FAO) concerning the legal or development status of any country, territory, city or area or of its authorities, or concerning the delimitation of its frontiers or boundaries. The mention of specific companies or products of manufacturers, whether or not these have been patented, does not imply that these have been endorsed or recommended by FAO in preference to others of a similar nature that are not mentioned.

ISBN 978-92-5-105583-0

All rights reserved. Reproduction and dissemination of material in this information product for educational or other non-commercial purposes are authorized without any prior written permission from the copyright holders provided the source is fully acknowledged. Reproduction of material in this information product for resale or other commercial purposes is prohibited without written permission of the copyright holders. Applications for such permission should be addressed to:

Chief

Electronic Publishing Policy and Support Branch

Communication Division

FAO

Viale delle Terme di Caracalla, 00153 Rome, Italy

or by e-mail to:

copyright@fao.org

© FAO 2009

Foreword

The Food and Agriculture Organization of the United Nations (FAO) has placed food security at the heart of its mandate and, through the Declaration of the World Food Summit held in November 1996, has reaffirmed the right of everyone to safe and nutritious food. Considerations of food safety and quality are now integral to that concept.

In collaboration with its member countries, other UN agencies, such as the World Health Organization (WHO), and national and international, governmental and non-governmental organizations, FAO has sought to improve the safety and quality of food products for over 50 years. This work applies to the whole food chain, from primary production, through processing, storage and transport, to marketing.

Throughout the years, FAO's Nutrition and Consumer Protection Division (AGN) has provided advice on strategies to improve the effectiveness of food control systems, covering both food safety and quality and, through a multitude of field projects, has helped disseminate the standards drawn up by the Joint FAO/WHO Codex Alimentarius Commission. It has also worked to strengthen national food control structures, to implement food safety assurance systems in small and medium enterprises, including the HACCP system, to train inspectors and to upgrade food control laboratories.

Recognizing the socio-economic importance of the informal street food sector, FAO has undertaken actions since the 1980s to improve the hygiene of food produced and sold on the street, using an integrated approach that embraces all the stakeholders, including vendors/handlers, consumers, municipal authorities, inspection services and local research and development institutions.

The first consideration in those actions is the informal nature of the street food sector which precludes a rigid approach based on repression. Indeed, the effective role of street food in responding to poverty cannot be ignored. The approach adopted has therefore privileged involvement and dialogue, based on the identification of locally experienced constraints and benefits, through socio-economic surveys, but also on local practices and conditions of hygiene and sanitation. This initial phase serves to produce a critical assessment and to propose actions that are tailored to reality and that underpin a policy of harmonious, integrated development of the sector by the local authorities, working in tandem with the different players.

An important component of related projects is training, whether of food vendors/handlers, inspectors or consumers. Such training can exist as awareness-raising, hands-on experience of new practices or more theoretical learning to give players the basic notions that will enable them to make their choices according to their circumstances.

AGN has implemented numerous projects in Africa during the last 15 years: in Benin, Burkina Faso, Cape Verde, Cameroon, Côte d'Ivoire, Democratic Republic of the Congo, Guinea, Guinea-Bissau, Morocco, Nigeria, Senegal, South Africa, Tanzania and Uganda.

Implemented together with the national and municipal authorities, those projects had the following objectives:

- to improve the conditions in which street food is prepared and sold;
- to strengthen the capacity of local authorities to control raw materials and prepared foods;
- to conduct more in-depth research on the street food sector: its socio-economic impact, the juridical framework and the hygienic and nutritional enhancement of the food;
- to raise vendor awareness of sanitation and food hygiene and to teach the nutritional value of foods through education and training;

- to share experiences and promote the formation of networks of local and national authorities at regional level in order to disseminate good practices and promote a common strategy;
- to raise consumer awareness of the nutritional and hygienic aspects of street food.

This manual collates the lessons learned from training given in such field projects. We hope that it will serve as a useful, practical reference tool that will help trainers to design their own workshops according context and target audience, and will thus promote street food that is safe and nutritious.

Ezzeddine Boutrif

*Director, Nutrition and
Consumer Protection Division*

Contents

FOREWORD	III
INTRODUCTION	VI
SECTION I	1
1. Contamination of street food	3
1.1 Microbial contamination of street food	6
1.2 Physical and chemical contamination of street food: agents and consequences	15
2. Hygiene and quality of raw materials and ingredients	19
2.1 Procurement of raw materials and ingredients	21
2.2 Requisite conditions for the transport, storage and preservation of raw materials and ingredients	30
3. Hygiene of food preparation and vending premises and equipment	39
3.1 Food preparation environment	42
3.2 Food preparation and vending equipment and utensils	45
4. Personal hygiene and hygienic methods and practices in the street food sector	53
4.1 Personal hygiene	56
4.2 Hygienic methods and practices in the preparation and sale of street food	67
5. Handling water in the street food preparation and vending	81
5.1 Supply, use and handling of clean water	84
5.2 Water hazard	87
6. Regulation and control of street food quality	95
6.1 Street food regulatory texts	97
6.2 Application of HACCP principles to analyse street food hazards	98
6.3 Examples of critical control points in street food	102
SECTION II	117
1. Notes to trainers	120
1.1 Pedagogical approach	120
1.2 Glossary: definition of key words	124
1.3 Answers to exercises	127
2. Illustrations and posters	132
2.1 Presentation of illustrations and posters	132
2.2 Adapting illustrations and posters to local contexts	139
SECTION III	141
ANNEXES: TECHNICAL FACT SHEETS	143
ANNEX 1: USE OF CHLORINE BLEACH	145
ANNEX 2: CARE AND CLEANING OF UTENSILS AND APPLIANCES	149
ANNEX 3: DIAGRAMS OF PROTOTYPE FOOD VENDING CARTS	155
ANNEX 4: CLEANING AND DISINFECTING FOOD PREMISES	165
BIBLIOGRAPHY	175

INTRODUCTION

■ IMPORTANCE AND CHARACTERISTICS OF THE STREET FOOD SECTOR

The street food sector offers ready-to-eat foods and beverages that are prepared and/or sold by itinerant or stationary vendors, especially on streets and in other public places. These foods account for a significant proportion of the daily urban food consumption of millions of low- and middle-income consumers. For many people with limited means, street foods are often the least expensive and the most accessible way of obtaining a nutritionally balanced meal outside the home, provided the consumer is informed and capable of choosing an appropriate combination of foods.

The preparation and sale of street food provides a regular source of income to millions of men and women in developing countries. However, their knowledge and expertise in food handling are often limited and they often engage in street food mainly to escape poverty, especially as little start-up capital is required. In Africa, the street food phenomenon has burgeoned in the last thirty years because of rural outmigration and urban population growth. The labour force has ballooned and commuting distances have increased, accentuating demand for ready-to-eat food near work. Street food is also able to provide outlets for urban and periurban agricultural producers and local food processors, thus contributing to local and national economic growth.

Today, local authorities, international organizations and consumer associations are increasingly aware of the socio-economic importance of street food but also of its associated risks. The main concern is food safety, although other problems exist, including sanitation (accumulation of waste on streets and blocked drains), congestion obstructing pedestrians (occupancy of pavements by hawkers and traffic accidents), the illegal occupation of public and private space and social problems (child labour, unfair competition for the formal trade sector).

The risk of food poisoning from street food remains a threat in many parts of the world, especially microbiological contamination. Foodborne pathogens pose a serious health hazard, essentially determined by type of food and method of preparation and preservation. One clear factor of risk is vendor ignorance of the causes of foodborne diseases. The risks to public health are exacerbated by poor hygiene, inadequate access to clean water and waste disposal, and unhealthy surroundings (proximity of drains and public discharge sites). The improper use of additives (often unauthorized colouring agents), mycotoxins, heavy metals and other contaminants (pesticide residues) are additional street food hazards.

Finally, while many consumers claim to consider hygiene when selecting their street food provider, they are often unaware of the associated health risks.

■ AIMS OF THE MANUAL

FAO proposes technical assistance to help national and municipal authorities to ensure the safety and quality of street food. As most itinerant vendors have received no training in food hygiene or sanitation and have to work under difficult and unsanitary conditions, FAO focuses on awareness raising and training of stakeholders in this complex system: handlers, vendors, consumers, official inspectors, representatives of associations or non-governmental organizations (NGOs), and so forth. As in any food preparation activity, it is important to know and apply the basic rules of food hygiene. FAO's assistance programmes emphasize the practical implementation of the Codex Alimentarius guidelines, especially the general principles of food hygiene and analysis of critical control points applied to street food, together with revised regional guidelines for measures to control street food in Africa.

This manual therefore collates accumulated experience in the training of informal street food operators in Africa. It sets out to cover gaps in basic theoretical knowledge, to explain the sources of contamination in food and the food processing chain, and to provide information and know-how appropriate to the constraints of the sector.

Accumulated experience from field activities has identified the following key factors in street food contamination:

- Poor conditions of storage of raw materials and finished products (exposure to dust, insects, pests, etc.).
- Insufficient cleaning of raw materials, ingredients and utensils before cooking, and of tableware used by customers.
- The use of utensils (saucepans and other recipients) likely to release toxic or dangerous substances into the food.
- Inappropriate handling of ingredients and raw materials, of food during preparation and of finished products.
- The prolonged holding of prepared food at inappropriate temperatures.

Designed in modular form, linking basic information with multiple illustrations and practical fact sheets, this manual aims to serve as a resource tool for trainers addressing different audiences: handlers, vendors and consumers, NGO agents and other support bodies active in the street food sector, hygiene inspectors and technicians specialized in food technology and nutrition. The training can be trainer training (representatives of vendor or consumer associations, relevant NGO agents) or direct training (inspectors, producers and vendors).

The manual centres on the five core sources of contamination (raw materials, environment and equipment, workforce and methods) and provides more details in areas considered relevant to street food: basic information to understand microbiological contamination, water and critical control points during food preparation, with an emphasis on those stages where corrective action can be instrumental, in other words adopting a risk-based approach.

These aspects are in Section I, which is supplemented with illustrations. These are designed to facilitate direct training activities and to supplement the text, which is geared more towards helping trainer trainers to devise their training programmes.

Section II proposes pedagogical tools and provides a narrative to help trainers design their programmes and tailor their training activities to the street food context.

Finally, Section III provides a series of technical fact sheets as technical support and as material to help answer the many concrete problems raised by participants (cleaning methods, hygienic transport of street food, etc).

Section I

MODULE 1

CONTAMINATION OF STREET FOOD

PLAN

TRAINING OBJECTIVE	5
KEY WORDS	5
1.1 MICROBIAL CONTAMINATION OF STREET FOOD	6
A. Classification of microorganisms	6
B. Physical and chemical factors influencing the development of microorganisms	9
C. Microbial contamination of street food: sources and consequences	11
D. Focus on the faecal hazard	14
1.2 PHYSICAL AND CHEMICAL CONTAMINATION OF STREET FOOD: AGENTS AND CONSEQUENCES	15
A. Physical agents	15
B. Chemical agents	15

TRAINING OBJECTIVE

The objective of this module is to provide street food players with basic notions, understanding and information on the causes of street food contamination and hazards to the consumer.

The module looks primarily at the microbial contamination of food and, to a lesser degree, to contamination from physical and chemical agents. This is not to say that the physical and chemical risks are unimportant, but we need to consider that:

- foreign substances can often be more easily spotted by the handler/vendor and therefore more easily eliminated;
- chemical contamination is often linked to raw materials that are already contaminated and over which the food handler has little control, apart from trading with “reliable” suppliers;
- contamination of microbial origin is usually invisible, but the food handler can significantly reduce such contamination through behaviour; hence the impact of training.

ON COMPLETION OF THIS MODULE, STREET FOOD HANDLERS/VENDORS AND OTHER PLAYERS SHOULD:

- know the main types of microorganisms responsible for food contamination and the factors and conditions that facilitate their presence and growth;
- be able to describe the major types of contamination that can affect food products and the resulting risks and harmful effects for consumers;
- be familiar with most forms of street food contamination by microorganisms harmful to humans and reduce their effects to a minimum.
- know the other forms of possible street food contamination and the physical and chemical agents responsible and associated risks;
- understand the consequences of inadequate hygiene during street food preparation, preservation and sale;
- understand the basic notions of the faecal hazard;
- be able to implement the actions, practices and behaviour needed to maintain and improve the sanitary quality of product during street food preparation and sale.

KEY WORD

**Contaminant - Food – Infection – Toxin – Toxic infection - Food poisoning
Proliferation – Microbe – Morbidity - Mortality**

1.1. 1.1 MICROBIAL CONTAMINATION OF STREET FOOD

Beyond plants and animals, there is also a vast population of living organisms that cannot be seen with the naked eye: these are microorganisms. Some are dangerous to humans when they colonize and grow on the food that we eat.

A. CLASSIFICATION OF MICROORGANISMS

Microorganisms exist everywhere, in every environment, in water, in air, in soil, and in the food we eat. They can only be seen through a **microscope (Illustration 1-1)**.

Microorganisms are usually classified into five major categories depending on their shape, size and form of life: bacteria, yeasts and moulds, viruses and protozoa.

A.1. Bacteria

Bacteria exist as individual cells or group of cells, all identical and interrelated in colonies. They are measured in micrometres (thousands of a millimetre). They exist in various shapes and also belong to several families with different traits. They can sometimes live and grow in nutritiously poor environments, including water. Others are more demanding and only grow in rich environments, such as milk, meat, prepared food, blood, and animal or human intestine. Some bacteria are useful for processing food; they cause fermentation as with yoghurt (lactic bacteria). Others have undesirable effects on food, producing gas, disagreeable odour, change in flavour. Still others are dangerous to consumer health and are known as **pathogenic bacteria**.

LEARN MORE

Bacteria can be grouped into four major families: coccus (spherical in shape, sometimes clustered like bunches of grapes), bacillus (in the form of rods), spirillum (in the form of spirals) and vibrio (curved).

Under ideal conditions, each bacterium divides in two every 20 minutes. Thus, after 8 hours, a bacterium has produced 16 000 000 bacteria. Microorganisms therefore multiply very quickly. The risk of food deterioration from microorganisms therefore increases very rapidly.

Under certain conditions (rarefaction of nutrients required for cell life) some bacteria, like *Clostridium* and *Bacillus spp*, can produce spores as a form of cell survival very resistant to heat and pH extremes, for example. The spore remains dormant until conditions for growth return, when it will germinate into bacterium of “normal” shape.

DESCRIPTION

A laboratory technician examining a microscope sample of food contaminated by microbes.

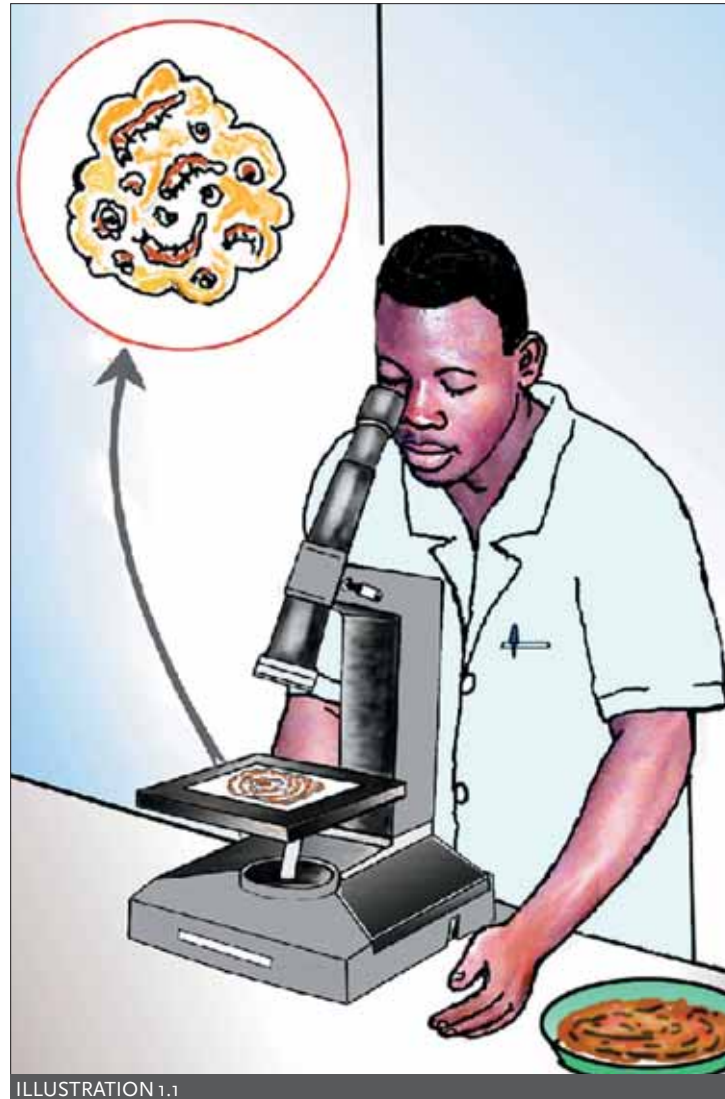

ILLUSTRATION 1.1

MESSAGE

Let's avoid contact between food and dirty environment (water, air, ground) to prevent contamination by microbes invisible to the naked eye.

A.2. Yeasts

Yeasts are made up of isolated oval or round cells measuring 3 to 10 micrometres in diameter, and therefore more than 10 times the size of bacteria. They essentially reproduce through budding.

Yeasts develop either on the surface or inside foods (solid or liquid environments). Some yeasts are cultivated industrially and commercialized for their specific properties of fermentation of sugars and partial transformation of these into alcohol and gas (production of beer and other fermented alcoholic beverages, production of bread using baker's yeast). Yeasts do not generally pose any danger to health, although some taint food and render it unfit for consumption.

A.3. Moulds

Moulds are microbes made up of several cells. They are referred to as microscopic fungi or mycetes. Their constituent cells are linked to each other by thin branching filaments called "mycelium". The mycelium attaches to the host medium (food, hides, fabrics, floors, walls, plants, human and animal skin) and its aerial part produces specialized reproductive cells. Moulds need air to develop. They exist as blotches of differing size and colour.

Moulds are used in industry, notably to produce antibiotics. But some cause disease in humans and animals through the toxins (called mycotoxins) that they produce, and are therefore a risk to public health. A case in point is Aspergillosis (*Aspergillus flavus* and close strains) which produces mycotoxins called aflatoxins. Aflatoxins are seriously hepatotoxic and hepatocarcinogenic (hepatic tumours or primitive cancer of the liver). Moulds are unfortunately resistant to heat and relatively insensitive to antiseptics. Any food carrying mould can be a source of contamination, like groundnut and other oilseed grains, maize, liquid or powdered milk and other dairy products.

A.4. Viruses

Viruses are much smaller than bacteria. They are only visible with a very powerful microscope, called an electronic microscope. Viruses are unable to reproduce when isolated. They can only multiply when they have penetrated another living cell whose energy and metabolic pathways they use: they are obligatory intracellular parasites. Viruses are parasites on both animals and humans.

Many cause relatively serious diseases such as viral hepatitis, measles, smallpox and rabies. For example, hepatitis A or endemic hepatitis is transmitted by water or by food that has undergone rapid superficial heat treatment (boiled egg, frozen, dried, undercooked and insufficiently reheated food). Seashells, flies, dirty hands and anything that has come into direct or indirect contact with the stool of carriers are also possible channels of transmission. The infectious agent is a virus that penetrates orally, enters the blood and settles in the liver. Sickness can be serious, especially during pregnancy. After a possible phase of jaundice, it can lead to cirrhosis of the liver.

A.5. Protozoa

Protozoa are microorganisms belonging to the animal kingdom. They have a single cell and are capable of displacement in liquid environments. Many are parasites in humans and animals. They are characterized by an ability to change into cysts or other forms of resistance.

Protozoa are responsible for some very serious illnesses, including intestinal disease like giardiasis and amoebiasis. In the case of amoebiasis, when the cysts penetrate our digestive tract through consumption of raw vegetables, the amoebae regain activity and rapidly multiply provoking dysentery, a condition characterized by frequent passing of bloody stool.

Giardiasis is a very common parasitic infestation in the world, causing loss of appetite, abdominal cramps, bloating, passing of gas, nausea and even vomiting. The agent responsible for the disease is *Giardia lamblia*. Epidemics normally arise from surface waters and the foods most commonly infected by this parasite are fruit salads, sandwiches, fresh vegetables and raw milk. Transmission is faecal or oral.

B. PHYSICAL AND CHEMICAL FACTORS INFLUENCING THE GROWTH OF MICROORGANISMS

Some factors influence the growth of microorganisms. To prevent or curb their development, which can spoil food and be harmful and dangerous to human health, it is important to understand the factors that facilitate their development or permit their destruction. The most important factors are: temperature, water, presence of oxygen, acidity and chemical composition of the environment.

B.1. Temperature

Many microorganisms are destroyed by high temperatures. Microbes can be classified in three groups, according to temperature conditions for their development:

- Those that “prefer” a low temperature of between -7 °C and +10°C are known as psychrophilic and psychrotrophic microorganisms. These can taint refrigerated foods, especially meat, poultry, fish and dairy products;
- Those that “prefer” medium temperatures of between 20 °C and 40°C (known as mesophile organisms that can grow at ambient temperature);
- Those that “prefer” high temperatures of between 45 °C and 65°C (known as thermophile microorganisms that are most likely to survive incomplete heat treatment).

In many cases, preparing and cooking food properly controls and reduces microorganisms, as most are destroyed by temperatures over 70°C. It is important however to remember that spores, the form of resistance of certain bacteria, can survive such temperatures and subsequently regenerate as pathogenic microorganisms.

B.2. Water

Microbes need water to live and develop. Foods contain varying quantities of water, depending on their type and nature. Foods of animal origin contain sufficient water for all microbes to develop and multiply.

LEARN MORE

WATERACTIVITY

Water in plant or animal tissues varies in “availability”. Measurement of this availability of water in different foods is given by the value of water activity (a_w) determined by ratio.

$$a_w = P_w / P_w^\circ$$

where:

P_w = partial pressure of water vapour of a solution or food;

P_w° = partial pressure of pure water vapour at the same temperature.

Depending on their availability in food, we distinguish two types of water: ‘free’ water and ‘bound’ water.

Bound water is retained by the molecular constituents of cells and thus unavailable for chemical reactions. Free water represents the bulk of water in fresh foods and foods that have been processed but not dehydrated. This is water available for chemical and microbiological reactions. It is responsible for the growth and multiplication of all microbes present in food. It can thus be the cause of food spoilage, contrary to the case of bound water. A high a_w value indicates a high quantity of free water. It is therefore important always to reduce the a_w to protect food. This means converting free water into bound water, for example by adding salt or sugar to a product. We can also reduce the a_w by drying foods, adding gelatine or vegetable gums, or by crystallizing the water in food as ice (frozen products). The resulting food will have an a_w of less than 0.9 and therefore be conducive to microorganism growth. This explains why these methods are used for food preservation.

In practice, the a_w of a food placed in a sealed environment corresponds to the partial pressure of water vapour exercised by the food, hence the following approximation:

$$a_w = \text{Equilibrium relative humidity (in percentage)} / 100$$

B.3. Oxygen

The presence or absence of oxygen is another factor of microbe growth. Microbes can be classified in three groups: those that require oxygen to multiply, the “aerobic” microbes (e.g. *Bacillus*); those that cannot grow in the presence of oxygen, the “anaerobic” microbes (e.g. *Clostridium*); and those that are capable of growth under varying conditions of oxygenation, the “optionals”. There is generally a mix of these three types of microbe in food, existing in perfect symbiosis. Their combined action can produce unfortunate effects on fruit juices, canned vegetables and other products because of significant gas production that causes spoilage and sometimes the explosion of canned goods.

B.4. Acidity of environment

The acidity of food products (measured by pH or concentration of hydrogen ions) is a determinant of microbe growth. Foods are classified as highly acidic (fruits and fruit juices: tomatoes, oranges, lemons), acidic (fermented maize dough, fermented cassava dough, sour cream) and non-acidic (meat, fish, eggs, oilseeds, fresh milk) according to whether their pH is below, equal to or above 4.5. Pathogens do not develop in highly acidic foods, but can survive.

LEARN MORE

A solution is chemically neutral when its pH is equal to 7; acidic when its pH is below 7 and basic when its pH is above 7. The lower the pH of a product, the higher its acidity. Acidic or basic products are more stable than neutral products. Products with a good shelf life (therefore stable) generally have a pH below 4.5, as in the case of fizzy drinks, fruits and fermented milks.

B.5. Chemical and nutritional composition of the environment

As with all living beings, microorganisms need nutrients to grow. The chemical composition of food is therefore an important determinant of inhibition or growth. The richer the food is in nutrients (proteins, glucids, vitamins and mineral salts) and water, the greater the potential for microorganism development; thus the higher the risk of food spoilage and contamination; and consequently the greater the hazard for consumer health. Most pathogenic microbes are demanding, but many germs are also capable of spoiling food that is very poor in nutrient content.

C. MICROBIAL CONTAMINATION OF STREET FOOD: ORIGIN AND CONSEQUENCE

The presence of microorganisms in street food (prepared dishes, snacks, etc.) can be the result of contamination of the raw materials used for food preparation or of insufficient protection of the food during preparation and/or holding until consumption. The raw materials used to prepare food are sometimes dirty, causing microbial contamination when cooking conditions are inadequate or ineffective. A major cause of microbial contamination of raw plant materials (ground fruits, leafy greens) is untreated human or animal organic fertilizer. Conditions are aggravated when these are not properly washed in clean water. Drinking water and ice sold on markets and streets are often contaminated with pathogenic germs, causing an array of diseases, including cholera.

The following diagram indicates how food can be contaminated.

Different causes of food contamination

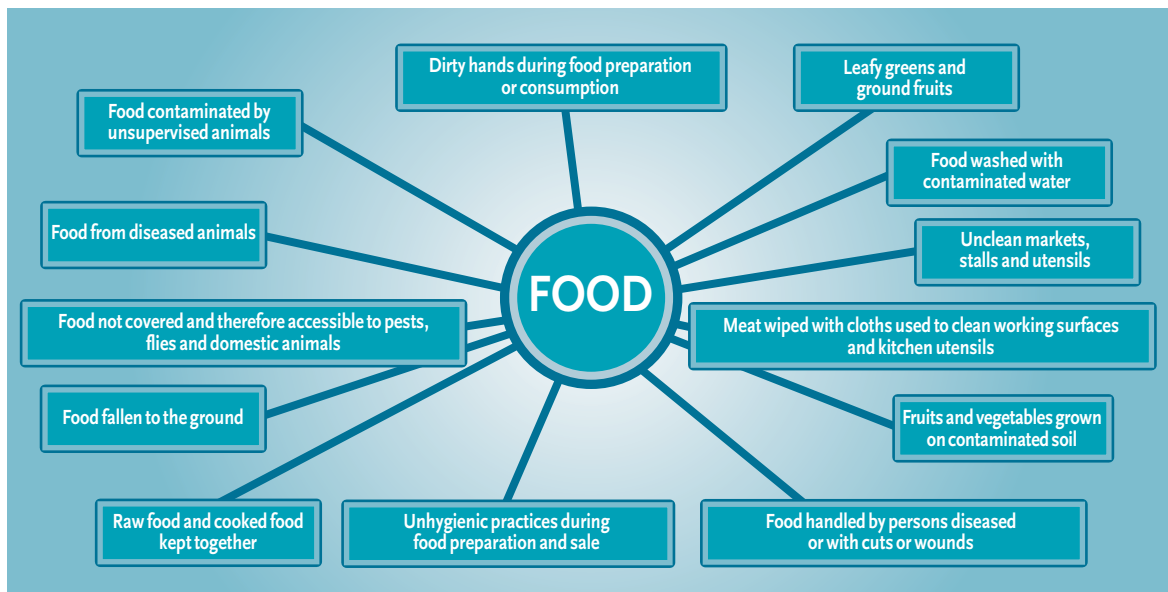

Diseases from the consumption of contaminated food vary according to microorganism and level of contamination. Such food-borne microbial diseases can affect one or several persons at the same time. They exist as infectious disease, parasitic disease and food poisoning. There are four categories of food-borne microbial disease:

- disease resulting from the presence of bacteria in food or multiplication in the intestinal tract of the consumer (infection), such as typhoid fever (caused by a *Salmonella*); this is also the case for coliforms, campylobacters, etc.;
- disease such as botulism, caused by the presence in food of toxins secreted by certain bacteria (food poisoning); such is the case of *Staphylococci* and *Clostridia*;
- disease caused by the presence of parasites (toxic infection) as in the case of ingestion of beef or pork with tapeworm or vegetables contaminated by dirty water or faecal matter rich in amoeba and roundworm;
- disease caused by natural poisons (food poisoning), such as mushrooms.

Foods commonly contaminated include dairy products (yoghurt, curdled milk), cooked dishes, sauces, raw vegetables, sandwiches, mayonnaise, animal products (meat, fish, shellfish), fritters and cakes. Water, ice and traditional beverages are also subject to microbial and parasitic contamination.

The following “learn more” table associates principal microbial disease with type of food consumption.

The purpose of food hygiene is to safeguard the food by preventing or reducing its contamination by microorganisms or parasites from water, air, flies, insects and pests. Food hygiene serves to ensure the safety and sanitary quality of food.

Microorganisms exist in water, air and soil but also in faecal matter that can contaminate water or soil. Faecal matter contains microorganisms and is thus also a source of many diseases.

LEARN MORE

Principal microbial and viral diseases associated with food consumption

DISEASES	MICROORGANISMS RESPONSIBLE	SOURCES	VECTOR FOODS
Botulism	<i>Clostridium botulinum</i>	Soil, water, intestinal tract of animals	Poorly sterilized pH>4.5 canned food, fish, salt cured food without nitrites, vacuum-packed food or food in oil
Typhoid fever	<i>Salmonella typhi</i>	Healthy carriers, faeces of diseased humans, water	Food rich in proteins (meat, egg, fish, milk), raw produce, shellfish
Dysentery	<i>Shigella dysenteriae</i> , <i>S. Sonnei</i> , <i>S. Flexner</i>	Faeces of the sick, water	Raw food, vegetables, salads, milk, water
Cholera	<i>Vibrio cholerae</i>	Faeces and vomit of infected persons, water	Raw food, vegetables, water
Malta Fever (brucellosis)	<i>Brucella melitensis</i>	Infected animals	Sheep milk and uncured cheese
Tuberculosis	<i>Mycobacterium tuberculosis</i> , <i>M. bovis</i>	Secretion of sick persons, animal milk	Raw milk in particular
Listeriosis	<i>Listeria monocytogenes</i>	Tissues, milk, urine of sick animals	Milk, milk products, meat, poultry
Intestinal anthrax	<i>Bacillus anthracis</i>	Sick animals	Raw meat, cold cuts
Tularaemia	<i>Francisella tularencis</i>	Blood and tissue of sick rabbits and hares	Rabbit and hare meat
Enteritis necroticans	<i>Clostridium perfringens C</i>	Animal faeces	Cooked meat and fish
Yersiniosis	<i>Yersinia enterocolitica</i>	Soil, water, animals (pigs)	Raw vegetables, meat, raw milk, water
Infection from Campylobacter spp	<i>Campylobacter jejuni</i>	Sick animals	Water, raw milk, chicken, shellfish
Salmonellosis	<i>Salmonella typhimurium</i> , <i>S. heldelberg</i> , <i>S. java</i> , <i>S. enteridis</i> , <i>S. montevideo</i> , <i>S. panama</i> , etc.	Faeces of domestic animals Skin, acne, nasal secretions	Meat, poultry, shellfish, fish, milk, eggs
Staphylococcal Enterotoxicosis	<i>Staphylococcus aureus</i>	Skin, acne, nasal secretions	Ham, meat, poultry, crustaceans, cheese, milk, cold cuts, salads, pastries
Enterobacterial infections	<i>Escherichia coli</i> (several serotypes) <i>Proteus vulgaris</i> (+3 other species) <i>Klebsiella pneumoniae</i> <i>Citrobacter aerogenes</i> (+other species) <i>Edwardsiella tarda</i>	Faeces, water, soil	Meat, poultry, raw milk and dairy produce, pastries, cooked food, eggs, fish
Toxic infections	<i>Clostridium perfringens</i>	Human or animal faeces, soil	Cooked meat and poultry, raw food
	<i>Vibrio parahaemolyticus</i>	Water and seafood	Fish, crustaceans, salted meat
	<i>Streptococcus faecalis</i>	Human and animal faeces	Meat, cakes, milk powder
Gastroenteritis	<i>Bacillus cereus</i>	Soil, dust	Cereal products, cakes, sauces, rice, meat, bread, fish, vegetables, milk
Aflatoxicosis	<i>Aspergillus flavus</i> (and close strains)	Soil, plants	Plant products (grains), milk
Other mycotoxicoses	<i>Fungi</i>	Soil, plants	Fruit, grains, milk
Hepatitis	<i>Virus type A</i>	Infected faeces, urine, blood	Milk, water, shellfish, citrus juices
Poliomyelitis	<i>Poliovirus</i>	Faeces, throat secretions of infected animals	Milk, water, pastries

D. FOCUS ON THE FAECAL HAZARD

Open-air exposure of infected faecal matter or urine, combined with transmission factors, causes a variety of significant diseases in developing countries. Such diseases stem from the ingestion of food or water that is contaminated by stool, dirty hands or unclean or poorly protected containers.

Such contamination is common in developing countries, resulting from inadequate or non-existent sanitary infrastructure for the disposal of faecal matter and urine (appropriate latrines).

D.1. Composition of faecal matter

Faecal matter or excrement is digestive waste comprising indigestible elements of food, microorganisms and digestive secretions from the digestive tract.

The combination “digestive apparatus + faecal matter” provides all the conditions needed for microbe development and multiplication (heat, humidity and nutrients).

The excrement of individuals with certain forms of sickness (dysentery, diarrhoea) has very high concentrations of harmful microbes and parasites (amoeba, tapeworm, roundworm).

Normal bacteria in the human digestive tract can cause discomfort to consumers. This is the case with *Escherichia coli* which is a normal commensal (living in symbiosis) of the human or animal intestine. However, certain strains of *E. Coli* are pathogenic and can lead to problems of differing intensity, including serious gastroenteritis (diarrhoea, vomiting, stomach cramps) among children. Foods most commonly contaminated include butter, yoghurt, cheese, milk, fish, water, fresh vegetables and meat.

There are many vectors of contamination, for example through material (e.g. during slaughter and gutting at the abattoir), through water (latrine overflow and liquid manure) and through butcher's boards, hands and clothing.

D.2. How does faecal matter transmit disease?

Faecal matter is one of the principal sources of contamination of water, food and subsoil. Contamination can occur in or near housing, for example from defecation on the ground or near food crops, or where latrines are close to wells or badly maintained.

Sewage from overflowing latrines directly exposes food and people to contamination from microorganisms, parasitic worms and other pests, and promotes the multiplication of flies.

Contamination can also be less direct, as when untreated excreta enter water sources and then the food chain, and thus transmit germs to persons living at some distance from the initial point of contamination.

Diseases transmitted by faecal matter are mostly diarrhoeal. They are infectious or parasitic in origin. They represent a major public health concern in tropical areas where they are a primary cause of mortality and morbidity.

D.3. Control of the faecal hazard

Control of the faecal hazard needs to be preventive. Control measures should place effective sanitary barriers between excrement (the vector for microbes and disease) and people.

The only places that are truly safe for toilet functions are properly built, covered latrines that have evacuation systems that do not contaminate the environment or water. Such latrines must always be placed at least 15 metres from housing and water points (wells, river, etc.).

GOLDEN RULES

Control of the faecal hazard must be preventive and requires the proper management and evacuation of excreta, the provision of clean water and application of the basic rules of personal hygiene (body, food, faecal and urinary).

- thoroughly washing your hands with soap and water after using the latrines;
- throwing all toilet paper and other used material into the latrine pit so it is not left to litter the ground;
- urinating and defecating directly into the latrine pit so the ground is not dirtied.

1.2. PHYSICAL AND CHEMICAL CONTAMINATION OF STREET FOOD: AGENTS AND CONSEQUENCES

Besides the biological agents (microorganisms) mentioned in the previous chapter, there are other agents responsible for endangering consumer health: chemical and physical agents. Thus, street food can be contaminated during preparation, keeping and sale by chemical and physical impurities originating from raw materials, equipment, hands and surroundings. Street food is rarely covered, so gathers dust from the immediate environment, vehicle exhaust fumes and impurities deposited by flies and other insects.

A. PHYSICAL AGENTS

Injuries can be caused by foreign bodies in food:

- shards of glass from broken bottles or overhead light bulbs,
- splinters of wood from surroundings, boxes, structures, etc.,
- stones,
- metal chips from surroundings, wire, etc.,
- small pieces of bone,
- personal belongings (jewellery worn by handlers), etc.

These agents exist because of poor practices from procurement to consumption. They can be eliminated relatively easily by good handler/vendor practices. They can cause a litany of consumer mishaps: broken tooth, choking, cuts, infection, etc.

B. CHEMICAL AGENTS

Chemical agents in street food can originate from a number of sources. Some of the utensils used release metal particles into the food, such as copper, lead and iron. Lead contamination of food can also come from the water used during preparation when the pipes are made of lead, or from pollution in the air as street food is often exposed to dust that can contain lead from vehicle exhaust fumes (**Illustration 1.2**). The surrounding environment can also cause other forms of contamination from heavy or assimilated metals, including cadmium, mercury and arsenic.

Several chemical substances are used in agriculture (fertilizers, pesticides, veterinary drugs). They are strictly regulated. Some substances are permitted while others are forbidden because considered dangerous. The regulations also specify doses and methods of application. If used sensibly and in compliance with regulations, these substances should not present a hazard to consumers.

However, unauthorized substances might sometimes be used, or authorized substances

inappropriately used (excessive doses, non-compliance with technical specifications), which can then pose a hazard to consumers. Plant raw materials on the market, such as fruits and vegetables, can sometimes contain pesticide residues, which can also feature in the drinking water. Animal raw materials, such as chicken, turkey offal and meat, are sometimes contaminated with chemical residues, notably veterinary products used during production. Finally, food additives like colouring, flavouring and preservation agents are not always rigorously used in street food, so it is important to check that supply sources are reliable and that additives are authorized and properly dosed.

REMEMBER

The consumption of products contaminated by microbes causes a variety of conditions: indigestion, vomiting, diarrhoea, dysentery, cholera, typhoid fever, paratyphoid fever, hepatitis, tuberculosis, parasitosis, etc.

Many chemical substances (heavy metals, unauthorized chemical additives, pesticide and veterinary drug residues) introduced intentionally or not into street food have proved to be toxic. Ingesting these substances through food causes a variety of conditions and complaints: allergies, anaemia, albuminuria, hepatitis, tumours, etc.

Exercise 1

1. What are the agents responsible for food contamination?
2. What are the possible origins of microbes that contaminate street food?
3. What are the consequences for the consumer of street food contaminated with microbes?

DESCRIPTION

A woman selling food in an area polluted by vehicle exhaust fumes (practice to be discouraged).



ILLUSTRATION 1.2

MESSAGE

Let's avoid exposing our food to vehicle exhaust fumes and reduce the risk of chemical contamination and harm to consumers.

MODULE 2

HYGIENE AND QUALITY OF RAW MATERIALS AND INGREDIENTS

PLAN

TRAINING OBJECTIVE	21	
KEY WORDS	21	
2.1	PROCUREMENT OF RAW MATERIALS AND INGREDIENTS	21
	A. Procurement channels	21
	B. Hygiene of purchase points	22
	C. Criteria for the selection of raw materials and ingredients	26
	D. Management of raw materials	28
2.2	REQUISITE CONDITIONS FOR THE TRANSPORT, STORAGE AND PRESERVATION OF RAW MATERIALS AND INGREDIENTS	30
	A. Transport of raw materials and ingredients	30
	B. Storage and preservation of raw materials and ingredients	31

TRAINING OBJECTIVE

The objective of this module is to provide street food practitioners with the basic knowledge and principles needed to guide them in the choice, purchase and management of good quality raw materials and ingredients.

On completion of this module, they should:

- know the basic principles to guide them in the selection and purchase of raw materials and ingredients;
- be able to assess the hygiene of the purchase points;
- know the fundamental principles to be applied during the transport, storage and preservation of raw materials and ingredients.

KEY WORDS

**Dirt – Spoilage – Microbe – Pollutant – Contamination – Germ – Perishable good
Sanitary quality – Contaminant – Official stamp – Pesticide residue**

2.1. PROCUREMENT OF RAW MATERIALS AND INGREDIENTS

A. PROCUREMENT CHANNELS

Street food operators generally procure their agricultural raw materials from two main channels. Some operators purchase their raw materials on the main urban markets, from retailers or from wholesalers who themselves procure their supplies from the rural sector. Others obtain their supplies directly from producers or from rural markets close to the urban areas. Some farm products, especially vegetables, are purchased from urban and periurban market gardeners.

Fresh animal products such as fish and eggs are purchased from market traders and urban producers (marine and lagoon fishers, poultry farmers).

The necessary finished or semi-finished products (rice, pasta, manufactured beverages, etc.) are purchased from traders or industrial production plants.

Purchases are usually paid in cash. However, in the case of some products (maize, millet, sorghum, wheat flour, bread, oil, meat, etc.), operators have regular suppliers with whom they sometimes have special social relationships and who sometimes agree to advance the merchandise on credit.

The procurement of raw materials and ingredients is also done through family links or clan networks. This enables street food operators to get good prices, regular supplies and credit. The women vendors sometimes band together in informal associations to buy in bulk and negotiate prices to counteract seasonal price fluctuations of certain raw materials.

First choosing a supplier and staying with that supplier are important aspects of food quality. When a good supplier has been found, it is important to try to convert the business relationship from sporadic purchase to trusted supply in order to involve the supplier in determining the necessary quality of product. Although the primary concern for most street food operators is usually price, the concept of quality has gradually entered negotiations of operators who have built successful businesses. The notion of “quality premium” can sometimes be introduced, a strategy generally used by agrifood corporations, but also relevant to the street food sector.

GOLDEN RULES

In all cases and whatever the form of procurement of raw materials and ingredients, it is important to carefully choose raw materials and ingredients from recognized traders who offer guarantees of sanitary quality.

B. HYGIENE OF PURCHASE POINTS

There are many different purchase points for raw materials and ingredients: fields, farms, family market gardens, rural markets, urban markets, butcher shops, fishery landing sites, shops, stores, etc. The state and cleanliness of the purchase point are often indicators (though not cast-iron guarantees) of a trader's professional approach. Also, unsanitary premises are likely to contaminate raw material of good quality, before purchase by the street food operator.

Street food operators need to consider the hygiene of purchase points when choosing suppliers, who should operate in clean surroundings:

- away from public refuse dumps, rubbish heaps, public toilets, animal pens, dustbins, etc. (**Illustration 2.1**).
- far from uneven ground that can catch stagnant water in the rainy season (**Illustrations 2.2 and 2.3**).

The purchase point and surroundings must be kept clean. They should be weeded if necessary and cleaned daily by sweeping, dusting, and collecting and destroying rubbish.

They should also be thoroughly cleaned at regular intervals, washing with soapy water and disinfecting the wall tiles and floor and eliminating insects and rodents (**Annex 2**).

GOLDEN RULES

The source of raw materials will determine the sanitary quality of the food. Therefore, before selecting and purchasing raw materials, street food operators must:

- know where the produce comes from by visiting the market stalls, the stores and the storage areas;
- if possible, find out about the conditions of transport and delivery of the produce;
- make sure that the produce has been carefully protected against all pollutants, the sun and bad weather.

DESCRIPTION

Purchasing meat from a clean stall: a woman buying meat from a traditional butcher. We can see:

the cleanliness of the surroundings:

- there is no rubbish or household waste;
- the merchandise is displayed with professional competence;
- the butcher is clean in appearance;
- he is holding a fly-whisk.

evidence of veterinary inspection:

- a visible stamp on the carcass (**practice to be encouraged**).

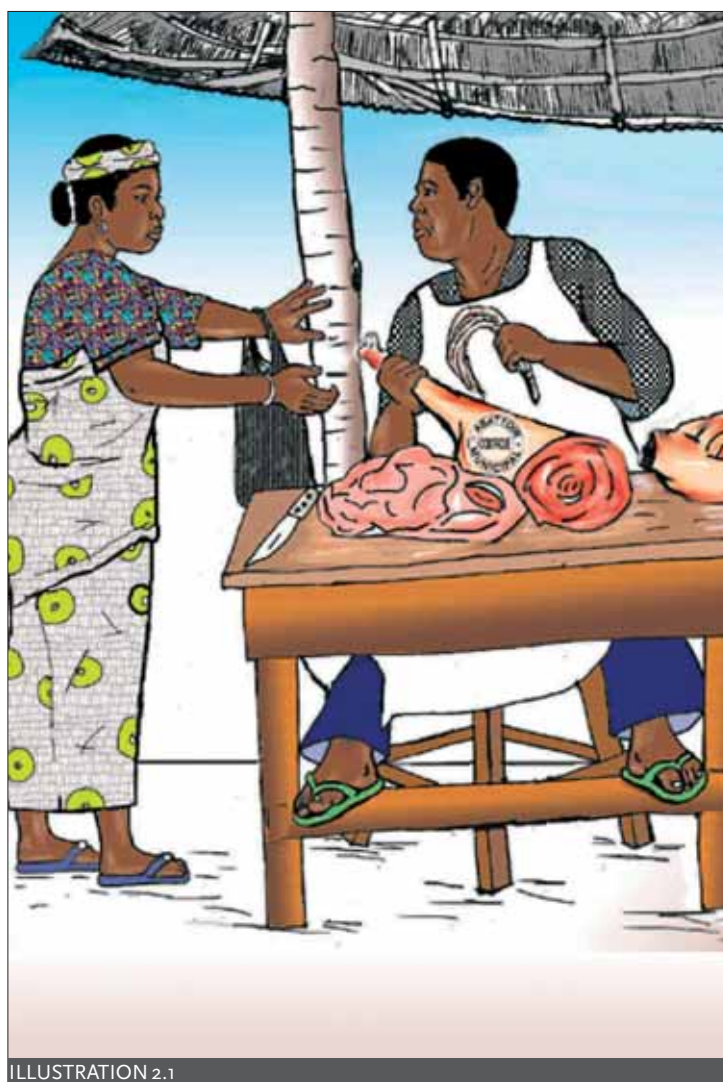

ILLUSTRATION 2.1

MESSAGE

I buy my meat from a clean butcher's stall with evidence of veterinary inspection.

DESCRIPTION

A woman buying her tomato, chilli and onion supplies from a vendor of fresh produce displayed in raised baskets in clean surroundings (**practice to be encouraged**).

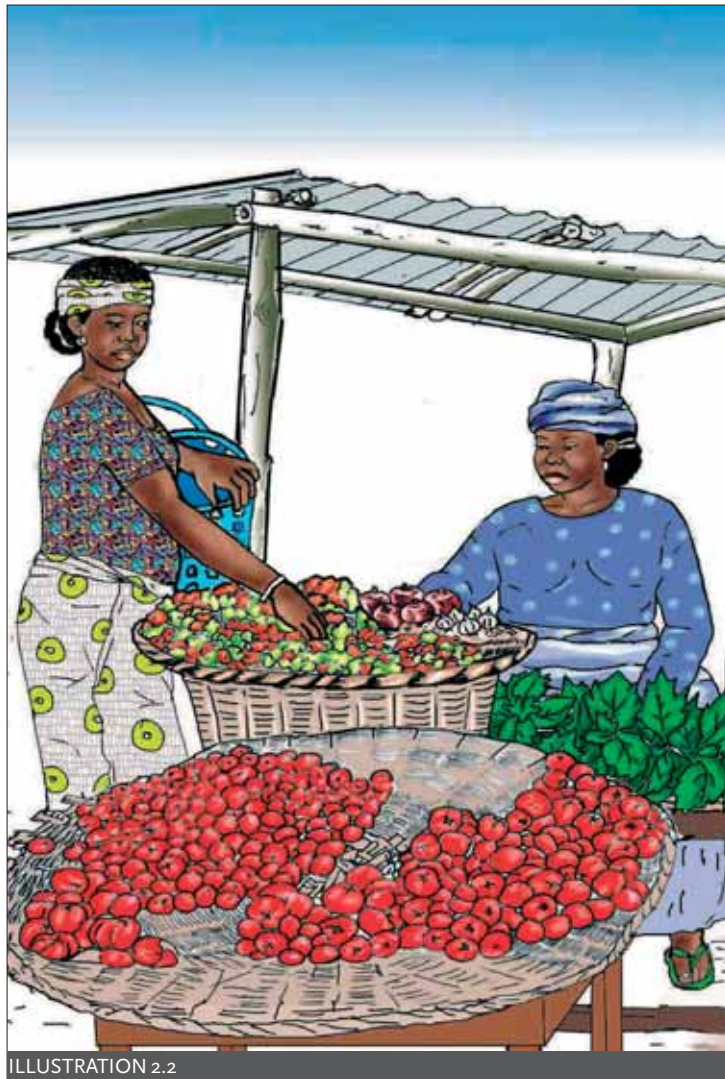

ILLUSTRATION 2.2

MESSAGE

I buy my vegetables and spices from a vendor who can guarantee their freshness and sanitary quality

DESCRIPTION

A woman buying vegetables and spices displayed on the ground in unsanitary surroundings (**practice to be discouraged**).

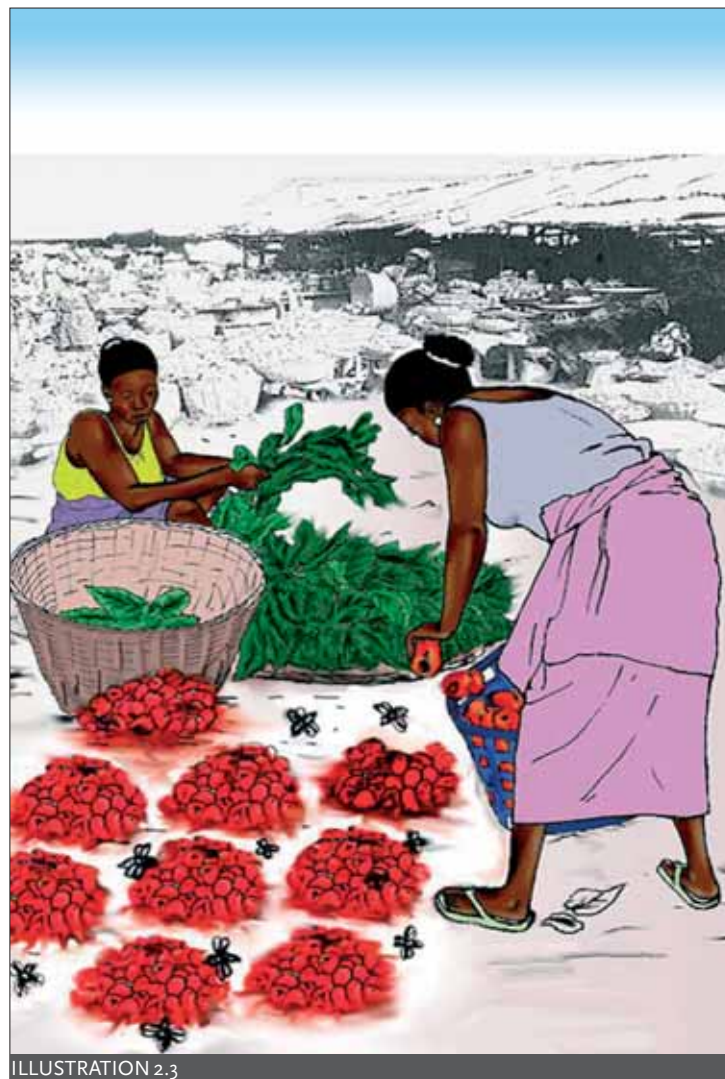

MESSAGE

Avoid buying raw materials displayed in unsanitary surroundings.

C. CRITERIA FOR THE SELECTION OF RAW MATERIALS AND INGREDIENTS

When selecting raw materials and ingredients, focus on their freshness, appearance, variety, quality and price, but also on the hygiene of the vendor and his surroundings.

The basic personal hygiene of the vendor is essential. He should wash his hands after handling dirty material or toxic products or after going to the toilet. He should keep his nails short as these can be breeding grounds for microbes.

The cleanliness of the vendor's clothing is an important measure of hygiene and a good indicator of professional rigour. Garments get dirty from vending activity and should be frequently washed. Better, the vendor/handler is strongly advised to wear an apron.

The street food operator should immediately cease all food preparation and vending activity in the event of diarrhoea, vomiting or skin wounds.

Food products sold on markets or from other outlets are not always of good quality. Some products may be deteriorated or spoiled.

GOLDEN RULES

It is essential to observe the following rules when purchasing food:

- visually check food to be used for prepared meals;
- do not hesitate to refuse any food that is tainted;
- always check the quality of produce (appearance, smell, foreign bodies, insects, etc.) and the display stand;
- avoid buying raw materials from vendors who do not observe the rules of personal hygiene, clean clothing and proper conduct.

Let's look at specific products:

► Fish

Fishery products require strict precautions that extend from catch to consumption, as they are very prone to spoilage (**Illustrations 2.4 and 2.5**).

Good quality fish should have:

- an appearance of freshness and firm flesh;
- fins that are intact and wet;
- moist and shiny pink or red gills;
- clear bright eyes that fill the whole orbit cavity;
- a tightly closed anus that is not greenish.

► Meat

The following rules and criteria apply when choosing good quality meat (**Illustration 2.6**):

- good quality meat should be bright red in colour; there should be no greenish, blackish or dark red colouring;
- good meat should not smell bad;
- swarms of flies over the display counter indicates loss of flavour and exposes the meat to

serious risk of microbial contamination;

- meat handled with bare hands and left in the open is exposed to serious contamination and should be avoided;
- meat recognized as fit for human consumption bears a veterinary stamp certifying the good health of the animal of origin.

▶ Fruit, vegetables and condiments

At the market, fruit, vegetables and certain condiments (chilli, tomato, onion, garlic, etc.) should always be bought fresh. One selection criterion for fresh vegetables is that they should be firm in appearance. Their skin should not be broken, nor damaged by pests. They should have no surface rot or dirt. Vegetables grown under poor conditions represent a real hazard for consumer health. Diseases are transmitted through the inappropriate application of manure and an excessive load of microorganisms or by irrigating vegetables with contaminated water. Misused pesticides leave residues in vegetables.

▶ Grains and seeds

Selected grains and seeds should be:

- whole;
- healthy and free of indications of rotting or spoilage such as to render them unfit for consumption;
- clean and practically free of visible foreign matter (stones, pieces of metal, rodent excreta, etc.);
- free of foreign smells and/or flavours;
- free of attack from pests, especially weevils and other parasites that can present a hazard to consumer health.

In theory, we could recommend that grains and seeds be free of microorganisms or heavy metals in quantities presenting a hazard to health and that they comply with the pesticide maximum residue limits of the Codex Alimentarius Commission, but it is very hard for the vendor/handler to check this in practice. Here again, supplier integrity and awareness are the only criteria the purchaser can check.

▶ Oils

Selection should be based on:

- colour: palm oil is red;
- shelf life for refined oils. It is essential to check the expiry date on the packaging.

▶ Flour

When choosing flour it is important to:

- avoid buying flour that is mouldy or that has been in contact with moisture;
- check for the presence of visible foreign matter (insects, stones, pieces of metal, rodent excreta, etc.);
- check that the products are free of foreign odour and/or flavour.

▶ Eggs

- at the market, avoid eggs exposed to sunlight;
- a good egg held up against the sun has no black mark.

▶ Canned food

Avoid buying:

- a can that is swollen as its contents are contaminated by microorganisms, some of which can cause a serious fatal sickness called “botulism”;
- a can that is dented, rusty or leaking;
- a can without expiry date or passed its expiry date. Purchasers are strongly advised to check the expiry date on cans.

D. MANAGEMENT OF RAW MATERIALS

When taking delivery of goods from a supplier or market, it is important to check that the products meet quality requirements. One way of ensuring quality is to have a regular network of suppliers who are fully aware of the quality criteria for raw materials and ingredients and are thus able to ensure their sanitary quality.

D.1. Labelling of raw materials and ingredients: mandatory specifications to be checked.

Processed foods should bear the following specifications:

- name of product;
- list of ingredients;
- quantity;
- name and address of producer, distributor or vendor;
- the shelf life of the product, which can be a use-by date or a best-before date, and storage instructions;
- the lot identification number.

▶ Use-by-date

This is used for perishable food and is written as “**use by day/month/year**”.

Example: use by 28/04/2004 means that the product is fit for consumption until and including 28 April 2004.

▶ Best-before-date

This is used for stable or stabilized food products (dried vegetables, cans...) and reads “best before day/month/year”. After that date, the product is still safe for consumption as it maintains biological stability but its organoleptic qualities begin to deteriorate.

D.2. Checking on delivery

Contamination is possible when packaging is damaged, when the use-by date is passed and, for chilled produce, when the cold chain has not been maintained. For example, traders often turn off their refrigerators at night to save electricity. They then turn them back on in the morning before the first customer arrives. This practice should be contested as food requiring chilling but left unchilled will soon spoil.

Preventive and surveillance measures are required: check the wrapping and packaging, check the use-by dates, check the temperature of goods on delivery and inspect merchandise visually.

GOLDEN RULES

QUALITY CRITERIA WHEN CHOOSING RAW MATERIALS AND INGREDIENTS

The quality of raw materials and ingredients determines the quality of end product. Poor quality can cause various forms of food contamination, indeed food poisoning.

Street food vendors/handlers should therefore purchase their basic supplies from sanitary surroundings and vendors who observe the rules of food hygiene.

Street food vendors/handlers should have a regular network of suppliers who are aware of the quality criteria for raw materials and ingredients and thus able to ensure their sanitary quality.

In particular, they should procure their meat supplies from approved butchers who can guarantee the sanitary quality of their merchandise.

Street food vendors/handlers should check the use-by dates and best-before dates and make sure they check products on delivery.

LEARN MORE

MEAT

Animal slaughter triggers a sharp reduction in energy reserve (Adenosine Triphosphate – ATP) and halts blood circulation which deprives muscle tissue of oxygen and causes other biochemical changes. The muscle proteins (actin, myosin) bind irreversibly. The result is cadaver rigidity or rigor mortis. In beef muscle, this process takes about eight hours at ambient temperature.

Meat should not be frozen before it has reached complete rigidity, and it should never be cooked in a state of rigor mortis.

The meat softens over time: this is meat “maturation”. Under these conditions, the meat texture improves after cooking.

But fresh meat is very perishable and any delay in transport, distribution and maturation requires refrigeration in the short term and preservation treatment in the long term. When purchasing meat, it is essential to check there is no exudate (meat fluid); its presence indicates deterioration and possible loss of flavour. Every animal is inspected by a veterinary officer before slaughter. There are two inspections:

- Inspection of the standing animal to check its state of health. This serves to identify and eliminate animals that are diseased, injured or unfit for consumption and that can transmit disease to humans. Such animals are withdrawn from human consumption.
- Inspection of the carcass which provides confirmation or otherwise of the sanitary quality of the meat. Meat recognized as fit for human consumption is marked with a stamp of approval (sign or seal in edible ink), certifying its sanitary quality.

LEARN MORE

FISH

Fish flesh is clean and aseptic. But as soon as fish dies, its tissues undergo very rapid deterioration due to: a proliferation of bacteria, a pH close to neutral and an abundance of substrates that provide a favourable environment for bacterial growth. Microbe proliferation produces malodorous and sometimes toxic volatile compounds, such as trimethylamine, methylmercaptan, dimethyl sulphide, hydrogen sulphide and ammonia. Fish can be contaminated at all stages of handling (fishing, unloading, transport, sale, etc.). The germs responsible are essentially concentrated at two levels: in the skin mucus (up to 100 000 germs/square centimetre of skin) and in the intestines (up to 10 million germs/square millimetre of intestine); and the action of endogenous enzymes which provoke the softening of muscle (proteases), the hydrolysis and oxidation of lipids (lipase, oxidoreductase) and discolouration of the flesh.

These transformations are slowed but not halted by reducing temperature. *Pseudomonas* for example only stop multiplying at about -5°C.

In addition, the action of certain bacteria on the flesh of fish (particularly tuna, sardine and mackerel) causes the formation of histamine. The ingestion of histamine produces food poisoning and allergic reactions which no thermal treatment of the fish (cooking, freezing, etc.) can destroy, once histamine has been produced. It cannot be detected by deterioration of flavour so the consumer is not alerted to the possibility of food poisoning.

2.2. REQUISITE CONDITIONS FOR THE TRANSPORT, STORAGE AND PRESERVATION OF RAW MATERIALS AND INGREDIENTS

A. TRANSPORT OF RAW MATERIALS AND INGREDIENTS

Markets are generally distant from street food stalls so purchased raw materials and ingredients need to be transported.

Transport should be hygienic to prevent products from becoming dirty or damaged and to safeguard their quality, especially their sanitary quality. Efforts should be made during the transport of raw materials and ingredients to reduce, if not eliminate, risks of deterioration and contamination from surrounding microorganisms and pollutants. There are two possibilities:

- ▶ Carriage in containers directly by the vendor/handler (basin, bowl, bucket, basket, etc.). In this case:
 - the containers should be washable, designed for the transport of food products and made of materials (such as stainless steel) that do not release dangerous and toxic chemical or physical substances into the products;
 - products likely to pick up dirt from contact with the soil (vegetables, fruits, etc.) should be separated from products of animal origin (meat, eggs, fish, etc.) (Illustrations 2.7 and 2.8);
 - low temperatures should be maintained for perishable goods, if possible using insulated containers (Illustration 2.9).

Care should be taken to ensure that purchased raw materials and ingredients remain intact during their transport by covering them with material or plastic film and protecting them from all forms of contamination and pollution. Chilled or frozen products should not be purchased at the start of a market to avoid leaving them in baskets or trolleys for long periods in the sun and at ambient temperature, which would hasten their thawing, contamination and spoilage. The transport of perishable goods should be as quick as possible, avoiding stoppages and by the shortest route.

- ▶ Transport by vehicle (car, motorcycle, cart, etc.). In this case, food products should be wrapped, then placed in containers to protect them from dirt and to significantly reduce the formation of water condensation.

Produce transported in car trunks should be arranged in such a way that there is sufficient circulation of air. Food products should not be in contact with the vehicle floor unless completely wrapped. Products not in resistant wrapping should not be placed on the ground during loading and unloading operations.

GOLDEN RULES

Good conditions of transport help maintain food quality and prevent the growth of microorganisms. So it is important when transporting food:

- to use a clean basket, basin, bucket, bowl or trolley;
- not to mix products of animal origin or these with products of plant origin in order to avoid cross-contamination. Meat and fish or meat/fish and vegetables should not be placed together without waterproof separation.
- during transport, temperature regulations should be observed and the cold chain maintained.

B. STORAGE AND PRESERVATION OF RAW MATERIALS AND INGREDIENTS

On return from the market, raw materials and ingredients should be properly stored. Poor storage conditions facilitate the proliferation of germs, pollution and food deterioration. It is recommended that meat be frozen to preserve its required characteristics. Freezing meat is becoming common practice within households. Freezers marked with four stars function at two temperatures: a freezing temperature of between -25 and -30°C and a single temperature of -18°C to preserve previously frozen and deep frozen products. Fresh poultry meat should be kept chilled at between 0°C and -4°C.

However, street food operators do not usually have refrigerators or freezers, which limits their food storage and handling capacity. Closed structures (cabinets, larders, drawers, jars, etc.) used to store food not under cold chain conditions should be large enough for orderly stowage. There should be separate sections for different food products. None should be placed on the ground and cluttering should be avoided. Bulk products, especially grains, should be kept in waterproof containers raised on clean tables or shelves, rather than in sacks, because of mice and other pests. Fumigation with appropriate gases or rapid impact insecticides should be applied against insects, but without any food present, and followed by airing and washing. If possible, fumigation should be left to experts. Traps rather than poisons should be used to eliminate rodents, as poisons can also be dangerous to humans. Vegetables and fruits are not inert bodies, even after harvesting. They should be handled with care and stored under good conditions. Each fruit and vegetable has an optimal storage temperature above or below which it is prone to some form of damage.

That temperature generally varies between -2°C and +10°C. Letters or fruit and vegetable symbols are often used to identify their refrigerator compartments. However, their storage temperature should be checked daily and their holding period kept as short as possible. Finally, food storage should follow the “first in first out” principle. The order of purchase and storage should be recorded for stock rotation, otherwise overlooked produce could start to rot, causing wastage, or eventually be used when no longer fit for consumption, exposing customers to risk. It is in the operator’s interest to devise an appropriate system and to avoid relegating old products to the back of the shelf when buying new ones.

GOLDEN RULES

It is essential to observe the following good conditions of hygiene when storing food products to protect them from pollutants, microbes and other harmful agents:

- keep products well wrapped;
- keep them in clean containers raised on clean tables or shelves;
- protect them with covers or plastic sheeting;
- keep storage facilities and shelves clean;
- systematically destroy all spoiled products;
- control insects and rodents;
- check the personal hygiene of staff entering storage facilities.

The storage facilities should be so designed that:

- they can be easily and thoroughly cleaned;
- air can easily circulate;
- they are protected against pests;
- no domestic animal is allowed entry.

Exercise 2

1. What are the key criteria or principles when selecting raw materials and ingredients? Give specific examples.
2. How can raw materials be stored for keeping on return from the market? Explain with specific examples.

DESCRIPTION

A woman buying recently landed fish. She buys her fishery products from suppliers who can guarantee their freshness and transports her purchases in an ice-cooler (practice to be encouraged).



ILLUSTRATION 2.4

MESSAGE

I buy my fish and fishery products from suppliers who can guarantee their freshness.

DESCRIPTION

A woman selling fish covered with flies; the street food operator gives her a miss and goes to another vendor whose fish, practices and conditions seem more hygienic (practice to be encouraged).

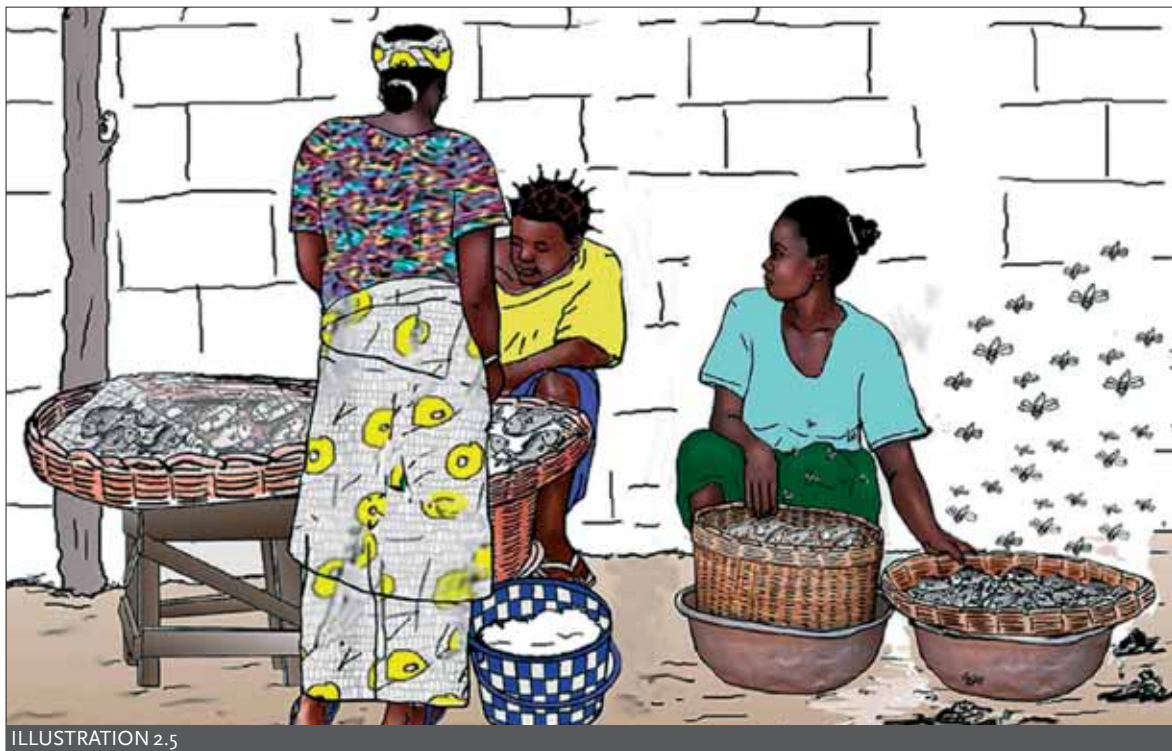

ILLUSTRATION 2.5

MESSAGE

Avoid buying fish and fishery products that are not covered and poorly kept.

DESCRIPTION

Purchasing meat from a hygienic stall (urban setting) like this modern butcher's (practice to be encouraged).

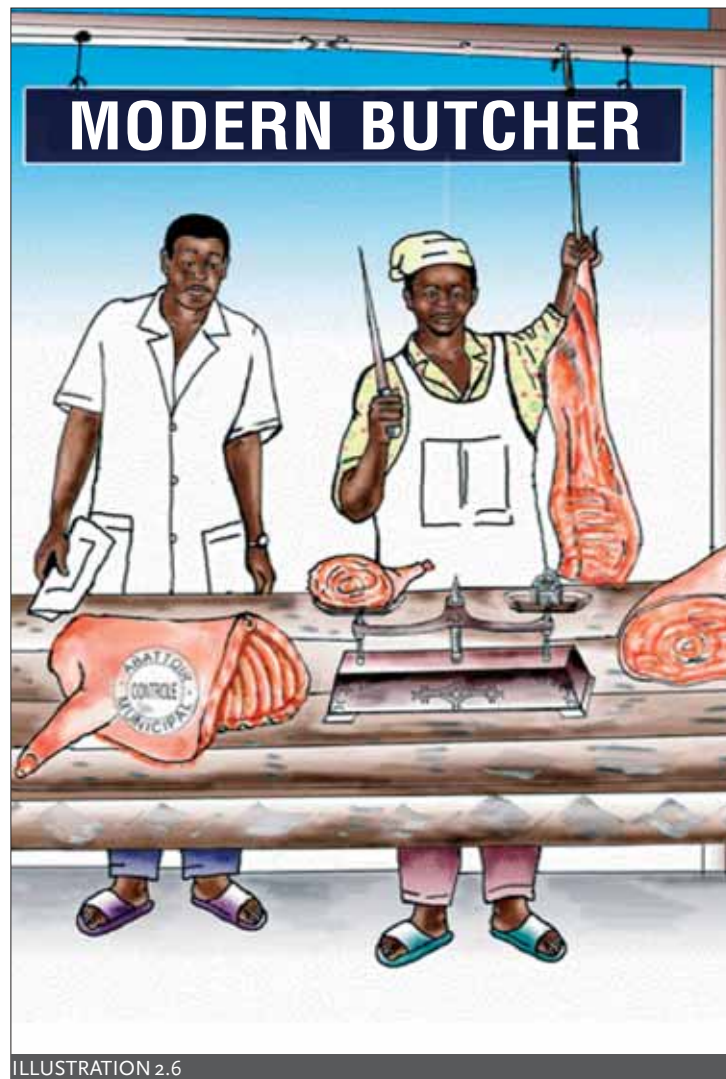

ILLUSTRATION 2.6

MESSAGE

In town I buy meat from a modern butcher's.

DESCRIPTION

On her return from market, a woman carries all her supplies (animal and vegetable products) in the same basket (**practice to be discouraged**)

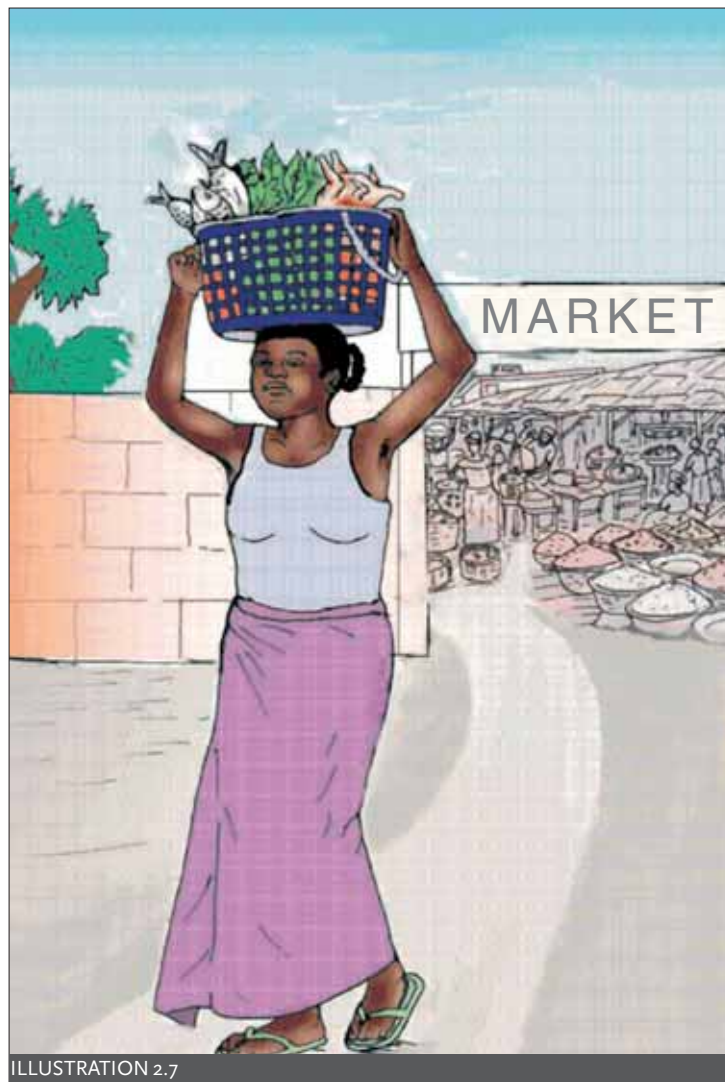

MESSAGE

Do not put all your purchases of raw materials and ingredients in the same basket.

DESCRIPTION

On her return from market, a woman carries her purchases in different baskets, some of them covered (**practice to be encouraged**).



MESSAGE

I cover my raw materials and ingredients against dust and dirt and avoid mixing them.

DESCRIPTION

A woman transferring her purchases from ice-cooler to freezer to avoid breaking the cold chain between purchase, storage and preparation of fish (**practice to be encouraged**).

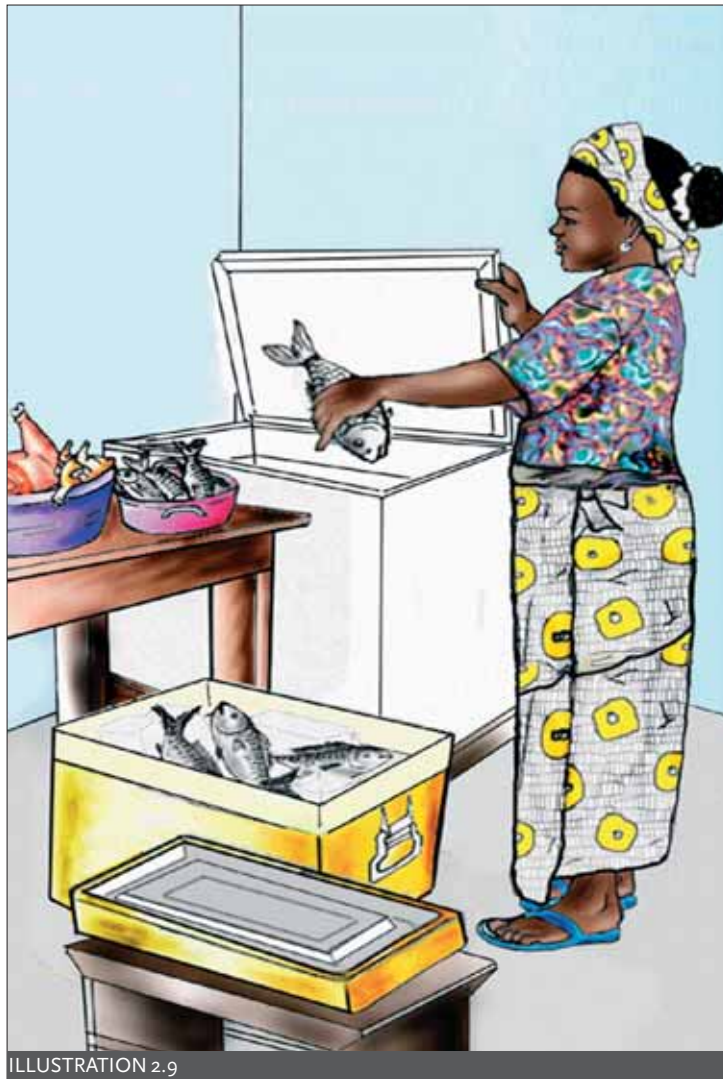

ILLUSTRATION 2.9

MESSAGE

Avoid breaking the cold chain between purchase, storage and preparation of meat and fish.

MODULE 3

HYGIENE OF FOOD PREPARATION AND VENDING PREMISES AND EQUIPMENT

PLAN

TRAINING OBJECTIVE	41
KEY WORDS	41
3.1 FOOD PREPARATION ENVIRONMENT	42
A. Environmental hygiene and location of preparation and vending premises	42
B. Establishment and organization of work premises	42
C. Pest control	43
D. Waste management	44
3.2 FOOD PREPARATION AND VENDING EQUIPMENT AND UTENSILS	45
A. Equipment and utensils required	45
B. Maintenance and storage of equipment	46

TRAINING OBJECTIVE

The objective of this module is to familiarize trainees with the rules of hygiene for street food preparation and vending premises and to encourage the application of those rules.

It deals with two of the five sources of food contamination. Having studied raw materials (module 2), this module focuses on the food preparation environment and the equipment.

Street food preparation and sale can in practice occur in the same place (especially on stationary food preparation/vending sites) or in different locations. The rules of hygiene are similar in both cases.

On completion of this module, street food operators should be able to:

- understand the principles of hygiene that determine the selection, location and organization of their place of work;
- determine the equipment and utensils required for the preparation and sale of food;
- understand the different methods of sanitizing and maintaining the equipment and workplace;
- understand the relevance of using specific equipment and applying rules of hygiene to ensure food safety.

KEY WORDS

Perishable food – Disinfection – Wastewater – Food hygiene – Refuse
Utensil/Equipment – Cleaning – Dishes – Pests – Pesticides – Food safety.

3.1. 3.1. FOOD PREPARATION ENVIRONMENT

The preparation and sale of street food should take place in a hygienic and well organized setting. Observing good rules of hygiene in the design, building and organization of the workplace helps to deal effectively with potential hazards and to ensure food safety.

A. ENVIRONMENTAL HYGIENE AND LOCATION OF PREPARATION AND VENDING PREMISES

Depending on the nature of the food preparation and vending operations and associated risks, the premises and utensils should be designed and fitted in such a way that:

- they are easy to maintain and disinfect;
- food contamination is kept to a minimum.

Observing of rules of hygiene in the design and building of the workplace, selecting an appropriate location and installing adequate facilities are necessary for keeping potential hazards at bay.

Street food preparation and vending sites should be at least 15 metres from refuse dumps and latrines.

Street food operators should keep the following basic principles in mind:

- the food should be prepared in a clean and well lit area, sheltered from sun, dust and wind, and far from all sources of contamination, such as solid waste, domestic animals, insects, rodents, etc.;
- fixed or mobile vending points should be located in an area where the risk of contamination from refuse, wastewater and other harmful or toxic substances is nil or minimal. If that risk cannot be totally eliminated, the displayed food should be covered and protected from contamination.

B. ESTABLISHMENT AND ORGANIZATION OF WORK PREMISES

A good location and organization of workplace are essential to ensure hygienic street food preparation and vending premises. Street food operators should keep the following principles in mind:

- the point of sale should not obstruct traffic or pedestrians and should not expose customers to road traffic or other hazards;
- the point of sale should be designed and installed for easy cleaning and maintenance;
- the place used for the preparation and sale of food should not also serve as accommodation or for storage of non-food products;
- the workplace should be orderly, with the raw materials and ingredients carefully placed on a clean kitchen table or counter;
- the food should be prepared in a clean and well kept place, sheltered from dust, sun, rain and wind, and far from all sources of contamination, such as solid waste (vegetable and fruit peel, leftover food, etc.) and liquid waste (wastewater, fish and meat fluids);
- the presence of domestic animals and unnecessary and potentially dangerous objects should be avoided;
- displayed food should be covered and protected from contamination;
- disorder should be avoided in the work area;

- the workplace should be organized in such a way that waste disposal is far from the cooking area;
- cleaning equipment (brooms, buckets, mops, etc.) that is often dirtied should be kept away from the work area;
- raw materials bought at the market should be unwrapped and carefully stowed away.

The work area should be kept clean by:

- removing dustbins, bags, wrapping and large waste;
- avoiding sweeping the floor in a dry state as this can raise dust which contaminates the food;
- regularly repairing damage to the floor;
- after food preparation, disinfecting the floor with chlorinated water (Annex 1).

C. PEST CONTROL

Pests (mice, cockroaches, termites, etc.) are a major threat to food safety and sanitary quality. Pest infestation can occur when there are breeding grounds and a source of food. Good hygienic practices should be adopted to avoid creating an environment favourable to pests. Good sanitization, inspection of raw materials and surveillance can minimize the risks of infestation and therefore limit the use of pesticides (insecticides, raticides, etc.). Pests should therefore be kept away from food preparation and vending sites.

▶ How to keep pests out:

- Food preparation and vending sites should be constantly kept clean and in good condition to eliminate potential breeding grounds.
- Openings and channels of access for pests should be protected or closed.
- To the extent possible, animals should be excluded from food preparation and vending sites.

▶ How to avoid attracting pests:

- The presence of food and water attracts pests. Food likely to attract pests should be placed in sealed containers, raised from the ground and stored away from walls. Areas inside and outside places with food should be kept clean.
- Waste should be kept in containers with lids to block access to pests.
- The presence of pests should be regularly checked in neighbouring premises and areas.
- Pest infestation should be promptly dealt with. Chemical, physical or biological treatment should be applied without risking food safety.

LEARN MORE

Streetfood centres:

It is possible to group street food vendors in specially designed centres. Grouping them makes it possible to provide common utilities and facilities (clean water, electricity, waste disposal, drains, toilets, parking area). It also means that shared equipment can be provided from a central point and cleaned there.

The rules on food hygiene that apply to open air markets and, in certain respects, to restaurants and fixed stalls, would apply to such centres.

D. WASTE MANAGEMENT

Humans produce all kinds of refuse when trading. Without care, that refuse can endanger consumer health. It is in fact a major source of contamination of food products and food preparation and vending premises.

Effective measures are therefore needed for the hygiene and sanitation of food preparation and vending sites and raw material and ingredient storage areas to prevent the contamination of food and surroundings. Good waste management is required in the form of their proper treatment and removal. Waste treatment and disposal systems should prevent food contamination from waste and from workers handling that waste. All waste should be handled and removed in such a way as to prevent the contamination of food, water and environment. Special care should be taken to keep insects, rodents, dogs, cats and other animals away from food waste.

Contamination of food, water and environment can be avoided by putting waste in waterproof covered bins. Care should be taken that the bins are not allowed to overflow and are emptied daily. To the extent possible, liquid waste, such as wastewater, should be separated from solid waste.

Liquid waste (except oils and fats) should drain into a sewer through a device (e.g. filter) that retains any solids present. Fatty waters should be eliminated by appropriate means, such as grease tanks. Solid waste should be placed in closed dustbins that are emptied at least once a day into the municipal refuse skip.

GOLDEN RULES

The following rules of hygiene will ensure good waste management:

- never throw food waste on the ground to avoid attracting insects, rodents and domestic animals (cats and dogs);
- eliminate solid and liquid waste separately;
- clean private refuse bins every day;
- prevent animals licking plates and utensils used in food preparation and sale.

3.2. FOOD PREPARATION AND VENDING EQUIPMENT AND UTENSILS

A. EQUIPMENT AND UTENSILS REQUIRED

The utensils used for preparing street food can be divided into two types: traditional and modern. The utensils are simple and are often the same as the ones used in the home.

▶ Traditional utensils

These are designed and made by local artisans. They include:

- implements to clean, peel and wash raw materials: winnowing basket, knife, gourd;
- implements for grinding and grating: hand-grater, pestle and mortar; grinding stone;
- implements for fermentation, decantation, sieving and filtration: jar, flask, sieve, basket, cloth;
- Utensils for mixing, kneading, extraction and cooking: earthenware or cast-iron cooking pot, wooden or clay tub, couscous pot, wood or cast-iron ladle, clay stove.

▶ Modern utensils

These are generally made of metal or plastic and include:

- basin, bucket, bowl, pan, sieve, skimmer, frying pan, strainer, plate, cup, fork, spoon;
- plate or hammer mill, mechanical grater, press;
- cookers, ovens, ...

Much of this equipment is still imported from Europe, US or Asia and is expensive. It is nevertheless gradually replacing the traditional utensils.

Utensils used for food preparation and sale should not be used for anything else. Utensils (pans, pots, etc.) should be kept clean. They should be made of materials that do not release toxic or dangerous substances (copper lead, etc.) into food or beverages, especially when these are acidic. The use of stainless steel, for example, is recommended.

Utensils should be in good condition and should have no hollow, groove or protrusion so they can be easily cleaned. Dented equipment and old utensils with damaged surfaces should be avoided, as these are more difficult to clean properly and become breeding grounds for microbes. For cleaning, it is better to use brushes than cloths and sponges which are themselves difficult to clean properly. For the same reasons of hygiene and sanitation, cooked and uncooked foods should be handled with different utensils.

Cutting boards should be kept in good order and without cracks, so they can be easily cleaned. A special board should be reserved for raw meat. A plastic cutting board is much easier to clean and keep in good order than a wooden board, which is difficult to clean properly.

Each vendor/handler should make sure that defective, damaged, cracked, rusty, chipped and generally unsuitable utensils and dishes are thrown away.

B. MAINTENANCE AND STORAGE OF EQUIPMENT

The good maintenance and proper storage of equipment and utensils used for food preparation and sale are essential for food safety. Bowls and plates should be turned upside down when not in use to avoid catching dust and foreign bodies. They should also be dried on a raised rack after washing and rinsing in clean water (**Illustrations 3.1, 3.2, 3.3 and 3.4**).

Recipients with table condiments should be kept clean and protected from pests. Washed and clean utensils and dishes should be handled, stowed and, for itinerant vendors, carried separately from dirty utensils and dishes and other sources of contamination.

GOLDEN RULES

- For the preparation and sale of street food I must use utensils that will not corrode, that can be repeatedly cleaned and disinfected, and that are made of materials that do not release toxic substances, such as stainless steel.
- All my cooking, serving and eating utensils (pots, pans, dishes, knives, forks, spoons, etc.) must be kept constantly clean. I wash them by hand as they are used in water and detergent and rinse them with clean water. They should also be treated with chlorinated water and again rinsed with clean water to avoid contamination (Annex 2).
- Washed boards, plates, pans and other recipients should be turned upside to dry and to avoid catching dust and foreign bodies.
- I regularly replace dented, cracked, scratched and rusty utensils to prevent them from becoming havens for dirt and breeding grounds for microorganisms.
- My dishes are washed in a different area to the food preparation area.
- Washed utensils are stowed in a clean area protected from pests.

LEARN MORE

CLEANING AND DISINFECTING

Cleaning removes food residues that can be sources of contamination. Cleaning methods and implements vary according to type of food, and disinfection might be needed after cleaning.

Cleaning can be done separately or jointly with physical treatment, including heat, scouring and suction and chemical treatment using the properties of detergents, acid or alkaline solutions.

Cleaning entails:

- removing visible surface residues;
- applying a detergent solution to remove dirt and bacterial film and to keep these in solution or in suspension;
- rinsing with clean water to remove detached dirt and detergent residues;
- disinfecting, then rinsing;
- draining or drying.

As a general rule, thorough decontamination of cooking utensils requires cleaning with detergent (washing-up liquid, special soap) and disinfecting with disinfectant (chlorinated water, commercial acid or alkaline products). There are products that combine cleaning with disinfecting, but for street foods we recommend using detergent for dishes followed by immersion in relatively strong chlorinated water (see the technical sheet on chlorinate bleach: **Annex 1**).

Application of a cleaning and/or disinfecting product should follow four conditions that can be remembered as TACT (mnemonic technique to help trainer recall: Temperature, Action, Concentration and Time);

- the product should be diluted and placed in contact with the utensil in water at a specific **Temperature** (often indicated on the label). The instructions for use need to be observed as a product acts differently in cold and hot water;
- soaking should be accompanied by **Action** in the form of energetic brushing to remove dirt and enable the product to act on all parts;
- the product should be used at a certain **Concentration**, often indicated on the label (see instructions for chlorine bleach: **Annex 1**);
- the utensils should be left to soak for a given **Time** (as recommended by the manufacturer).

Exercise 3

1. How can we organize the monitoring and detection of pests?
2. How can we eliminate pests without the risk of food poisoning?

DESCRIPTION

A woman draining her dishes in a raised plastic basket (practice to be encouraged).

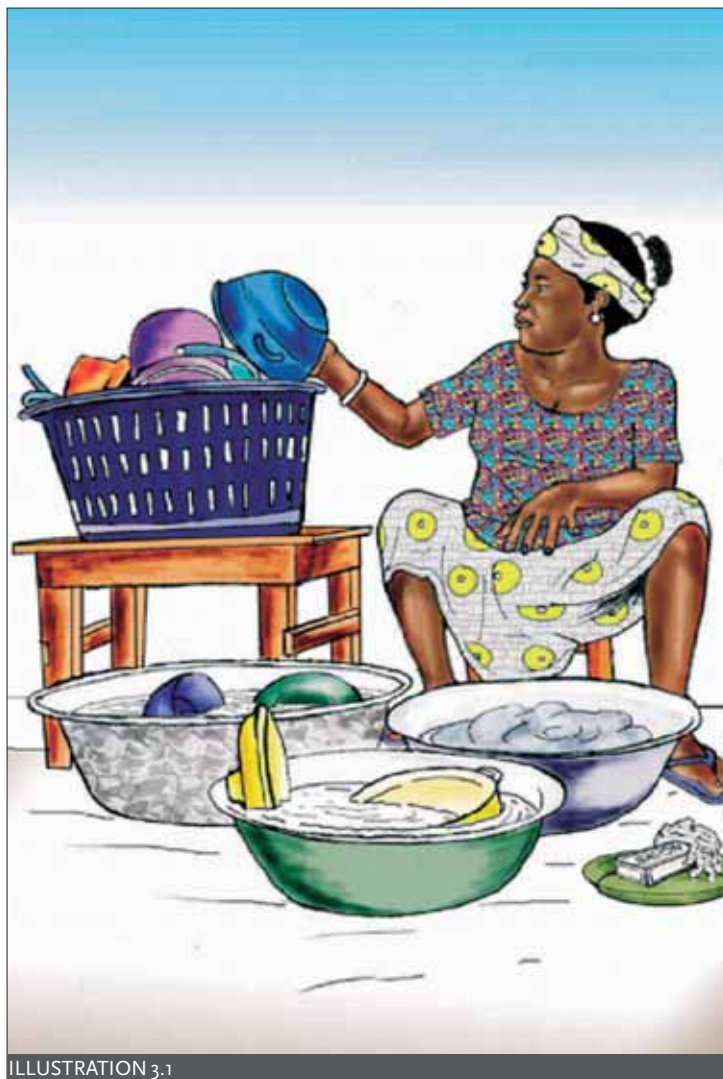

ILLUSTRATION 3.1

MESSAGE

After washing and rinsing in clean water without detergent, I dry my dishes in a raised plastic basket.

DESCRIPTION

In clean surroundings, a woman washes her dishes in a basin of soapy water. She has two other basins with clean water for rinsing. There is also a dish with a bar of soap (**practice to be encouraged**).

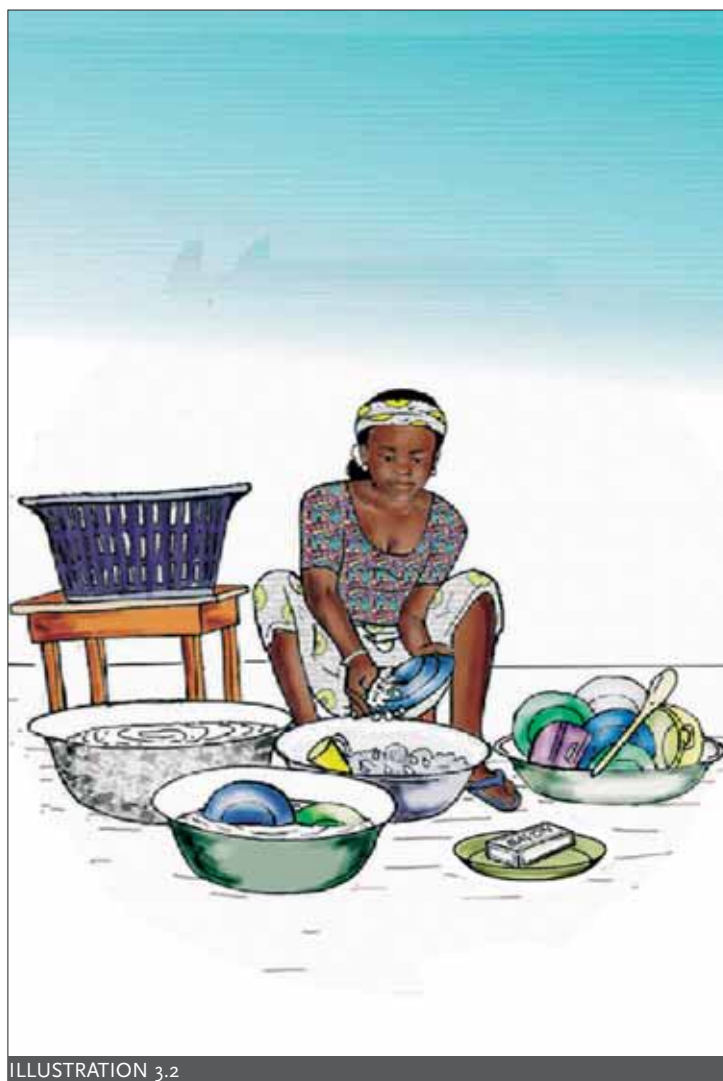

ILLUSTRATION 3.2

MESSAGE

I always avoid washing up in unclean surroundings to reduce microbial contamination. After washing, I rinse my dishes in two basins of clean water.

DESCRIPTION

A woman carefully ordering her cooking utensils to make best possible use of space; the cutting boards and saucepans are hung from nails in the wall; the dishes are stacked in plastic mesh baskets (**practice to be encouraged**).



ILLUSTRATION 3.3

MESSAGE

Carefully order your cooking utensils and lids to have more space in your kitchen.

DESCRIPTION

A woman washing up on the ground in unhygienic conditions (practice to be discouraged).



ILLUSTRATION 3.4

MESSAGE

I avoid washing up in unhygienic surroundings to reduce microbial contamination.

MODULE 4

PERSONAL HYGIENE AND HYGIENIC METHODS AND PRACTICES IN THE STREET FOOD SECTOR

PLAN

TRAINING OBJECTIVE	55
KEY WORDS	55
4.1 PERSONAL HYGIENE	56
A. Personal hygiene	56
B. Hygienic clothing	56
C. Hygienic conduct	60
4.2 HYGIENIC METHODS AND PRACTICES IN THE PREPARATION AND SALE OF STREET FOOD	67
A. Preparing food	67
B. Transporting and keeping prepared food	72
C. Selling street food	72
D. Cleaning and disinfecting	73
E. Managing unsold food	73

TRAINING OBJECTIVE

This module deals with the two last areas of potential contamination: risk relating to workers (personnel) and practices (methods and techniques of food preparation). Even if the hygiene rules applying to raw materials, the environment and conditions of food preparation, preservation and distribution are observed, there is still no assurance of sanitary quality and safety of end product because the vendor or handler may be unaware of the basic rules of hygiene applying to their person, conduct and work methods.

The objective of this module is to provide trainees with basic notions of hygiene concerning their person, conduct and work methods.

On completion of this module, street food operators should:

- be familiar with the notions of hygiene associated with food preparation and sale;
- master the principal notions of personal hygiene, hygienic clothing and proper conduct recommended for street food handlers;
- apply the rules of hygiene for street food handling and sale.

KEY WORDS

Street food – Food hygiene – Contamination – Bacteria – Food handler
Food safety – Dishes.

4.1. PERSONAL HYGIENE

The safe handling of street food calls for the application of rules of hygiene of person, clothing, conduct and practices.

Persons who do not meet an appropriate level of personal cleanliness, who have certain infections or who behave improperly can contaminate food and transmit diseases to consumers.

A. PERSONAL HYGIENE

A street food handler should be clean and keep his person clean throughout the food preparation and sale process so as not to taint the food. He should immediately cease activity when affected by diarrhoea or vomiting or when incurring boils, injuries or lesions on exposed skin.

Women street food vendors should avoid brushing their hair or arranging their braids or earrings on the premises (**Illustration 4.1**).

It is difficult to get workers to report health problems if they think they will be penalized (loss of wages, etc.). The employer needs to fully understand the importance of taking a sick employee off food preparation and vending duties. That employee could instead be temporarily assigned to other work not involving direct contact with food. An agreement to that effect will encourage the reporting of health problems.

B. HYGIENIC CLOTHING

Street food handlers should wear appropriate clean clothing that does not trail in the food. They should also wear a clean apron, preferably white or light in colour (**Illustrations 4.2, 4.3**).

It is important to distinguish between work clothes and normal clothes. The beginning of the workday should be marked by a change in clothing. Work clothes should be clean so the food is not tainted during preparation. There should be arrangements with employees for work clothes to be systematically washed after the day's work. Work clothes should preferably be light in colour, which makes it easier to check their cleanliness. The clothes should help the handler not to contaminate the food he is preparing and should therefore not trail in the food, hamper movement, or have pockets from which objects can fall into the food.

Hair is another source of contamination, so hair should be kept very short or should be covered with a clean headscarf.

Gloves are also recommended as they are easier to clean and disinfect than the skin of the hand, which is rough and can harbour microorganisms under the nails. However, gloves also need to be washed, like hands, especially if in contact with money or objects that can contaminate food. Wearing gloves does not mean disregarding the suggestions for general hygiene. It is, however, unusual to see gloves worn in the street food sector.

Visitors admitted to food preparation or handling areas should wear clean clothing and observe the other rules and practices of good hygiene.

DESCRIPTION

A woman having her hair done while serving food
(practice to be discouraged).

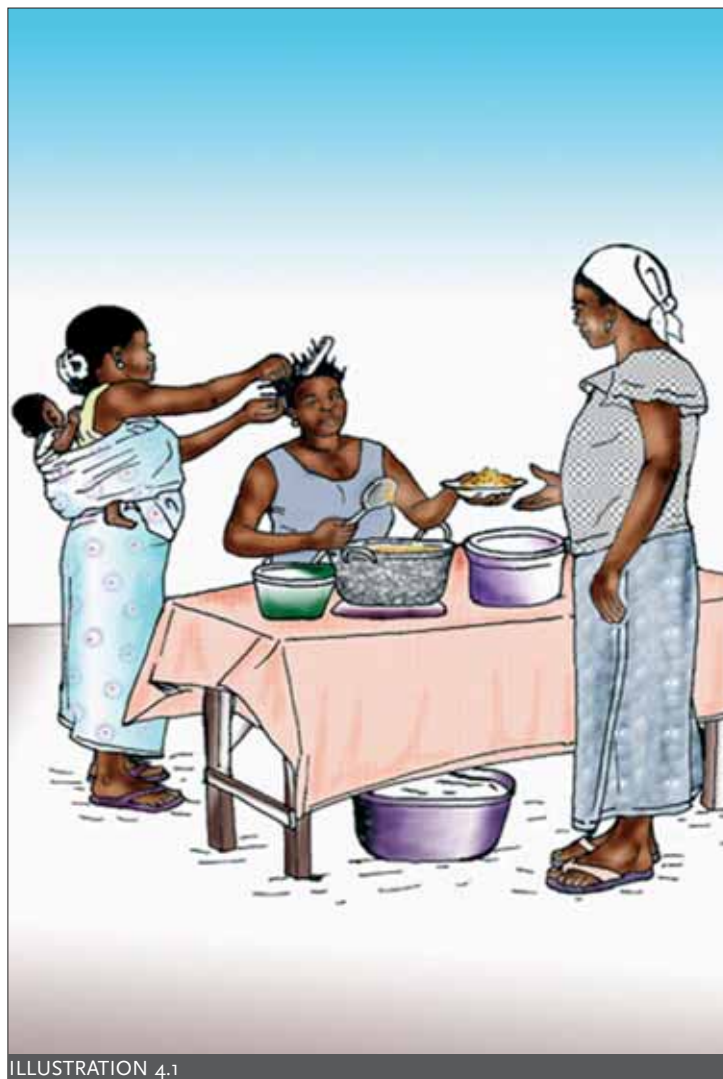

ILLUSTRATION 4.1

MESSAGE

For my personal hygiene and the safety of the food I sell, I make sure I am clean and avoid doing my hair where the food is prepared and sold.

DESCRIPTION

A woman wearing clean clothing, an apron and headscarf. Her assistant is also very clean (**practice to be encouraged**).



ILLUSTRATION 4.2

MESSAGE

Where food is prepared and sold, a vendor should always be clean and properly dressed to avoid contamination.

DESCRIPTION

A woman serving food while improperly dressed
(practice to be discouraged)

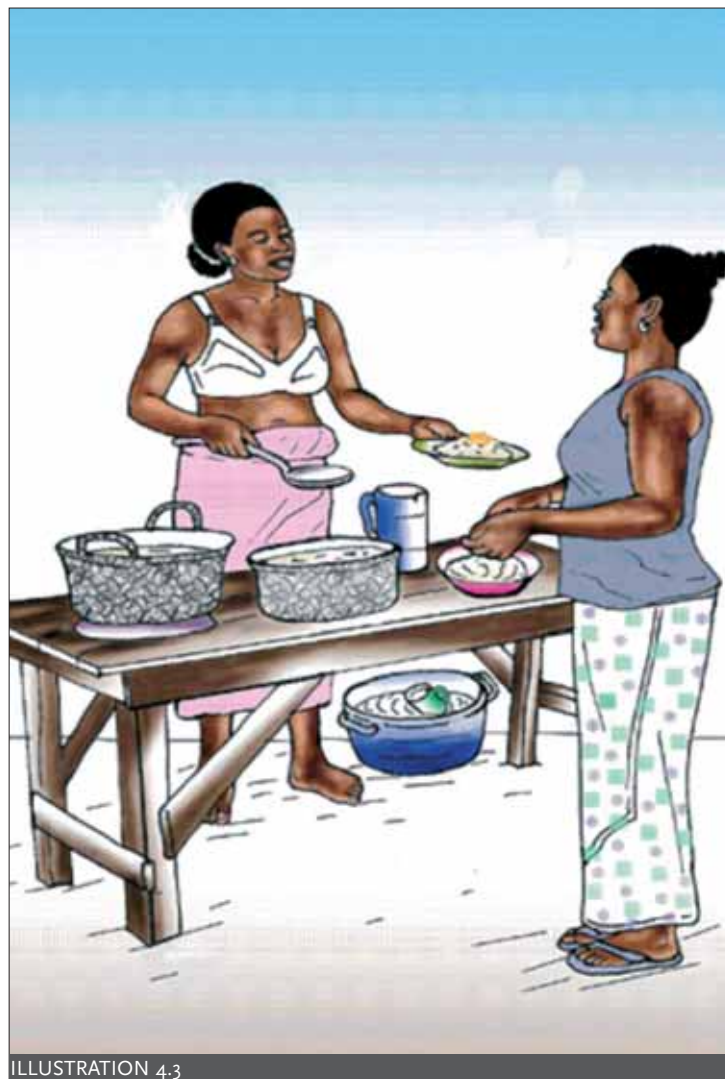

MESSAGE

I should not be dirty or improperly dressed to avoid contaminating the food I am selling.

C. HYGIENIC CONDUCT

All food handlers should wash their hands with soap and water:

- after handling raw products;
- after touching cooked food;
- after going to the toilet;
- after touching dirty objects such as a dustbin or money;
- after being in contact with toxic substances, such as pesticides.

The food handler should refrain from all unhygienic practices during the preparation and sale of food and will especially avoid:

- tasting food directly from the ladle (**Illustrations 4.4 and 4.5**);
- smoking or chewing tobacco, chewing betel or chewing-gum or picking his teeth;
- serving customers with his hand (**Illustrations 4.6 and 4.7**);
- chatting during the transaction (**Illustration 4.8**);
- touching his mouth, tongue, nose, eyes, etc., during food preparation and sale;
- spitting, blowing his nose, sneezing or coughing above or near the food (**Illustration 4.9**).

GOLDEN RULES

- It is forbidden to eat in the kitchen when it has not been fitted for that purpose.
- Operators should carefully wash (e.g. take a shower) in the morning before work and in the evening after work.
- It is essential to wear work clothes and head covers (scarves, caps); wearing gloves is recommended for food handling operations.
- Efforts should be made to wash work clothes every day.

DESCRIPTION

A woman directly tasting a sauce (or other food) from the cooking spoon (practice to be discouraged).



ILLUSTRATION 4.4

MESSAGE

To avoid contamination, do not directly taste the food you are preparing from the cooking or serving spoon.

DESCRIPTION

A woman tasting food placed in the palm of her hand
(practice to be encouraged).



ILLUSTRATION 4.5

MESSAGE

Taste sauces (or other food) from the palm of your clean hand.

DESCRIPTION

A woman using her bare hand to serve customers (**practice to be discouraged**).
The customer objects (**practice to be encouraged**).



ILLUSTRATION 4.6

MESSAGE

I avoid serving customers with my bare hand.

DESCRIPTION

A woman serving a customer with a fork
(practice to be encouraged).

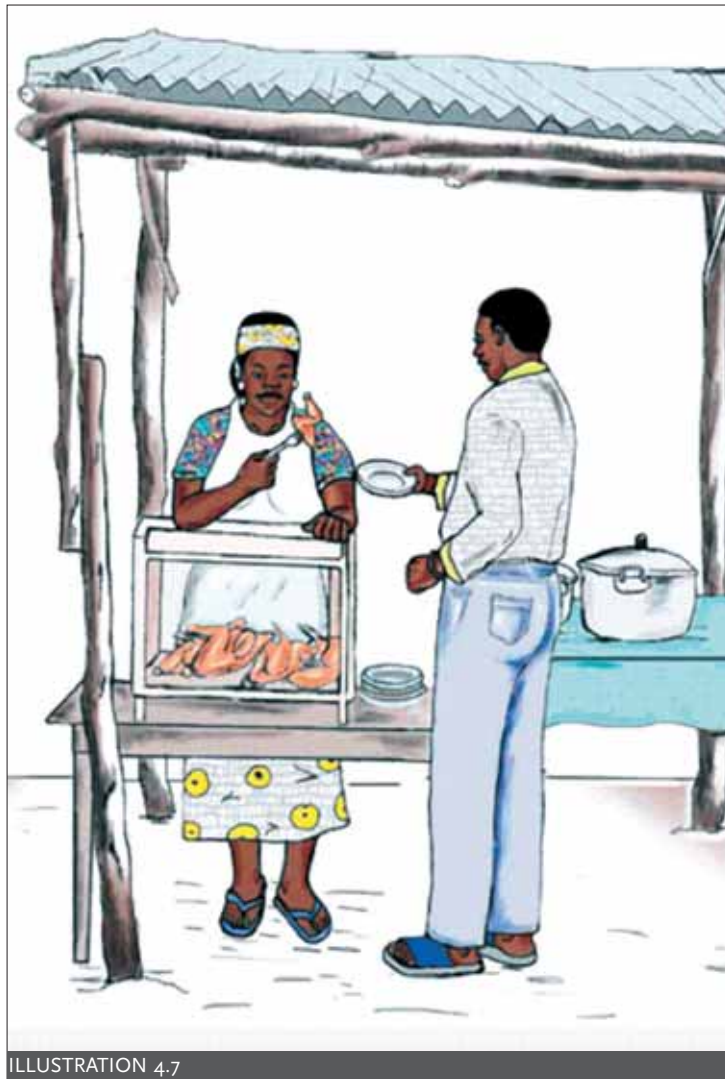

MESSAGE

To avoid contamination from my bare hand, I serve customers with an implement (spoon, fork, ladle,...).

DESCRIPTION

A woman talking and sputtering over the food she is serving (practice to be discouraged).

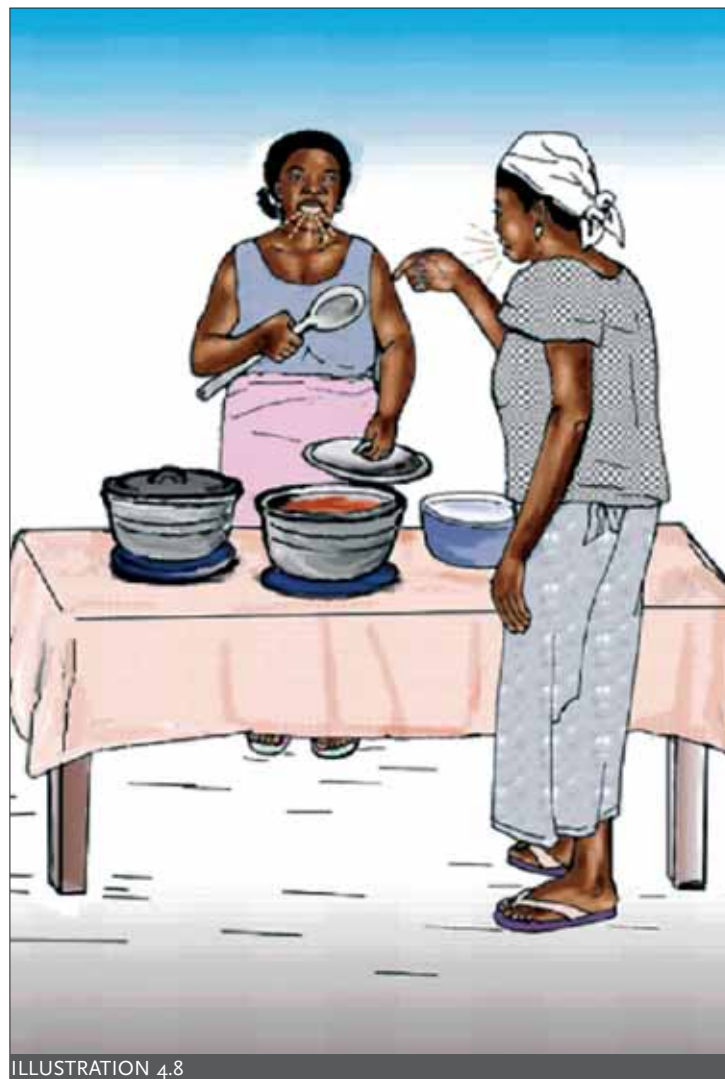

MESSAGE

I avoid talking over the food I am serving.

DESCRIPTION

A woman blowing her nose over her food
(practice to be discouraged).

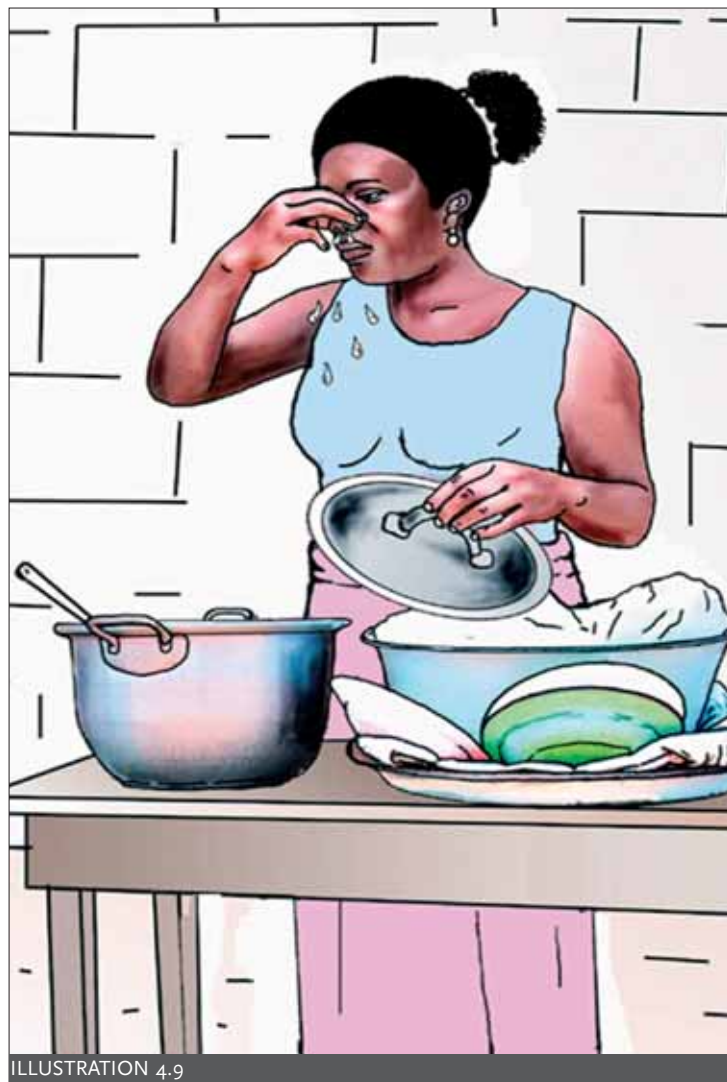

MESSAGE

For food safety and hygienic premises, I avoid blowing my nose near the food.

4.2. HYGIENIC METHODS AND PRACTICES IN THE PREPARATION AND SALE OF STREET FOOD

These are important measures and precautions that need to be rigorously applied during food preparation and sale to ensure its quality and safety. They are essential for the hygiene of food prepared and sold on the street.

A. PREPARING FOOD

Some vendors/handlers prepare their products at home for subsequent cooking at vending point in front of the customer. This practice tends to inspire customer confidence and, in many cases, to improve flavour and customer satisfaction. But the food still needs to be prepared according to the basic rules of hygiene in order to be safe.

Sickness from contaminated food is usually the result of unhygienic conditions and practices. The following preparation practices and conditions should therefore be avoided:

- food prepared and kept too long before sale. This gives bacteria time to grow to dangerous levels. The ideal temperature for microbial growth is between 10 and 60°C;
- food are not sufficiently heated: the minimum temperature of 70°C required to make a product safe is not reached;
- the persons handling the food are infected and thus contaminate it.

One important principle when preparing food is to **avoid direct or indirect contact between raw food and cooked or prepared food**. This does not include the addition of salt, chilli, pepper and other condiments to cooked food shortly before eating.

N.B. Indirect contact can also be by cutting board, knife or hands passing from unclean raw product to cooked product.

The following precautions can be taken to reduce food contamination:

- raw materials and ingredients should be carefully washed in lots of water before use;
- cereals, pulses, vegetables and fruits (especially if consumed raw) should be soaked in clean water (preferably running water) and carefully washed to remove contaminants sticking to their surface (**Illustrations 4.10 and 4.11**);
- raw vegetable and fruit dishes (e.g. salads and peeled or sliced fruits) should be prepared making sure that the basic product is clean (careful washing in clean water) and that cutting board, hands and knives are also clean;
- meat, fish and similar foods should be separated and therefore not in contact with other products to be consumed raw;
- it is important to process primary produce quickly so that microbes do not have time to grow to harmful levels. Remember that at 37°C the microbial population of a food product doubles every 20 minutes; a single germ can become one billion germs in just 10 hours;
- if products are to be processed by heat (fried, grilled, roasted, etc.), they need to be properly cooked, which means that the temperature throughout those products should reach at least 75°C. The temperature therefore needs to be checked in the parts that are difficult to heat (centre of the food item, in larger pieces, etc.).

In practice, and given that there is usually no thermometer available for street food preparation, the following indicators can be checked:

- for grilled meat: the meat is no longer pink at the centre and the cooking juices released are clear and not pinkish;
- for dishes in sauce: the sauce boils, with the duration of boiling depending on the size of food items;
- food should not be reheated more than once, and only the portion to be served should be reheated;
- implements used to taste food should be washed immediately after each use.

Frozen products are increasingly used as raw materials in the street food sector. This permits product diversification and adds flexibility to the management of supplies. But it also raises the problem of keeping those products (freezers are rarely available in the street food sector) and of mastering the rules of handling and use. These are new products so there is no traditional know-how to guide vendors/handlers on how to use, store and defreeze them correctly.

Defrosting should follow certain conditions:

- in a refrigerator or thaw cabinet maintained at 4°C;
- under clean running water maintained at a temperature not exceeding 21°C for a maximum of four hours;
- in a microwave oven, but only when the food is to be transferred into a traditional appliance for continued cooking or when the whole cooking process takes place without interruption in the microwave oven.

Frozen products need to be thawed before use. Defrosting can be skipped when recommended by the manufacturer, especially vegetables. In contrast, large chunks of meat or poultry need to be defrosted before cooking.

Certain rules apply to beverages:

- drinking water and water used for hot or cold beverages should be safe water, clean boiled water or water disinfected by chemical agent before use;
- ice should be made from safe water. It should be handled and stored away from all sources of contamination.

Food handlers should always be mindful of the key notions of hygiene relating to street food, especially the preparation and sale of food for children.

GOLDEN RULES

To ensure that street food has a high standard of hygiene:

- cook the food well;
- consume the food immediately after cooking;
- keep cooked food in a good state of hygiene and at an appropriate temperature (in a cool area or refrigerator at 4°C or, if hot, above 65°C according to keeping period and type of food);
- reheat refrigerated food properly;
- avoid contact between uncooked and cooked food, including indirect contact through utensils or containers;
- frequently wash your hands during food preparation, especially after handling unclean food or toxic products, going to the toilet, scratching your head, nose, etc.;
- make sure all kitchen areas and surfaces are spotlessly clean;
- protect food against insects, rodents and other animals.

DESCRIPTION

A woman sorts, washes and blanches leafy vegetables before use (practice to be encouraged).

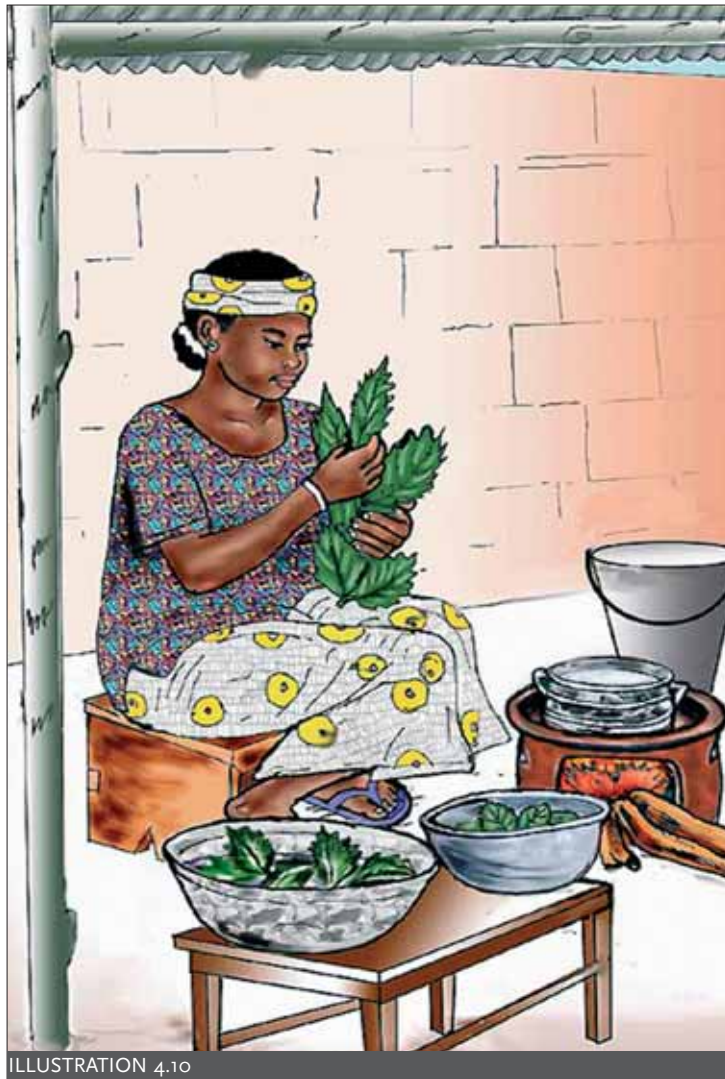

ILLUSTRATION 4.10

MESSAGE

Before using food items, make sure they are properly cleaned and prepared.

DESCRIPTION

A woman uses two bowls of water to clean and rinse condiments to make sure they are clean and hygienic before grating and use (**practice to be encouraged**).

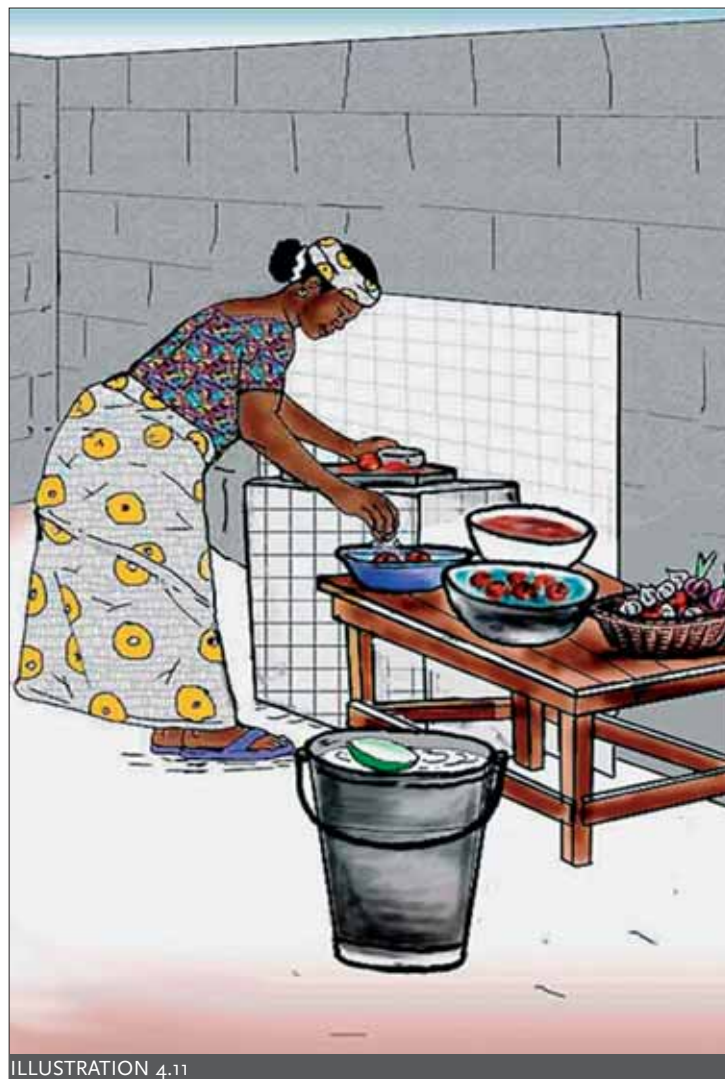

ILLUSTRATION 4.11

MESSAGE

Carefully wash food and condiments before preparation and use.

B. TRANSPORTING AND KEEPING PREPARED FOOD

Without effective control and protection during transport, food can become contaminated and rendered unfit for consumption at destination, even when adequate hygienic measures are taken upstream in the food chain.

Ready food and beverages to be delivered to the point of sale should be placed in clean containers with lids and well protected, especially if the transport time is long (**Illustration 4.12**).

Perishable goods (dairy products, etc.) should be taken to the point of sale in insulated containers, at low temperature (4°C).

The transport vehicle should be clean. It should not be used for carrying animals, toxic substances or other contaminants, unless fitted with separate compartments. If the vendor/handler has to make a long journey every day, he can regularly use the same carrier (e.g. collective taxi) and gradually sensitize him to the notion of hygiene of transport. In any case, transport problems are simplified if the point of sale is close to the preparation site.

For mobile vendors of food and beverages, prototypes of practical and hygienic vending carts are presented in **Annex 3**. These include:

- a countertop with central stove and cover;
- a glass panelled cabinet for food protection and sale;
- a closed container for beverages.

C. SELLING STREET FOOD

The action of selling street food is important hygienically. Most instructions on location and facilities have been covered in Module 3. Other hygiene measures include:

- the points of sale, whether stationary (kiosk, stall, etc.) or mobile (pushcart, tricycle, etc.) should be in good condition and meticulously cleaned, especially surfaces on which the food will be placed;
- displayed food should be protected from dust, insects and exhaust fumes with lids, glass panes, plastic sheeting or other materials that are easy to clean and that do not release toxic substances;
- displayed street food should be protected from contamination by surroundings and kept at the following temperatures:
 - ▶ food served hot: 60°C or more (high temperature)
 - ▶ food served cold: 7°C or less (low temperature)
- tableware for food and beverages should be easy to clean. Leaves for wrapping food should be carefully washed before use and not be reused;
- plates and utensils used by customers, whether with leftovers or not, should never be licked by domestic animals, such as dogs and cats;
- food to take away should be wrapped in paper, plastic or any other appropriate clean material. Newspaper, cement bag paper and paper already used as unhygienic wrapping should not come into direct contact with the food;
- where the vendor has no refrigerator, cooked food should be kept hot at a high temperature (60 - 65°C) so it is served hot. This prevents microbial growth when the display period exceeds 3 to 4 hours (**Illustration 4.13**);

- customers should be provided with means to wash their hands, including:
 - ▶ a bowl with water and detergent soap;
 - ▶ a bowl with tap water to rinse their hands.
- the water with detergent and the water for rinsing hands should be periodically changed. Dish and floor cloths should be regularly washed and replaced. A tap and soap are recommended for stationary vending points, where affordable (**Illustrations 4.14, 4.15 and 4.16**).
- although rarely used by street food operators, a refrigerator is strongly recommended once the vendor/handler can afford it. It is a good way to prevent microbe growth on and in food. But reheated food should never be returned to the refrigerator; it should all be consumed or what is left should be thrown away.

D. CLEANING AND DISINFECTING

On completion of food preparation and vending operations and before leaving the premises, it is important to systematically:

- clean and disinfect the floor but avoid sweeping it in a dry state (**Annex 4**);
- wash and disinfect sponges, dish cloths and floor cloths. Dish cloths should not be used without being washed beforehand;
- clean, disinfect and thoroughly rinse, with running water, dishes, utensils, cutting boards and work surfaces and store everything away clean and protected from dust;
- empty the kitchen dustbin into the municipal refuse container or appropriate facility, then wash, disinfect and stow it away.

Water with detergent should be used for cleaning. For disinfection, water with chlorine bleach should be used (**Annex 1**), followed by rinsing under running water. Module 3 explains the sense and purpose of cleaning and disinfecting, and the sequence of operations (removing large particles, washing with detergent, rinsing, disinfecting, rinsing), abiding by the rules of TACT (Temperature of application, Action to be applied, Concentration of product and Time of application).

E. MANAGING UNSOLD FOOD

Unsold food and beverages that cannot be kept appropriately should be discarded at the end of the day, as they could eventually pose a risk to consumer health.

To avoid such losses, street food operators should carefully measure their production so that nothing is left over at the end of the day. However, there will sometimes be unsold production. When this occurs, a vendor without a refrigerator (temperature below 10°C) or similar equipment should be encouraged to throw the unsold part away or use it as animal feed.

Where unsold food is refrigerated, large quantities of warm food should not be placed in the refrigerator as bacteria will continue to grow at the centre of the food that will remain warm (above 10°C) for a long time. It is better to store food in small shallow dishes so that all parts of the food can cool rapidly. The principle “**first in, first out**” should apply to the rotation of stocks.

It is generally possible to conserve dry or acidic foods and certain fermented foods for relatively long periods when these are stored in a cool, dry place protected from dust and pests.

GOLDEN RULES

It is very dangerous and strictly forbidden to mix one day's unsold food into the next day's batch.

Exercise 4

Ensuring food safety requires regular washing of hands which should become a reflex action.

1. What are the rules of hygiene that ensure the proper management of household waste?
2. When should you wash your hands when selling street food?
3. How should you wash your hands when preparing and selling street food?
4. What are the five rules of cleaning for street food hygiene?

DESCRIPTION

A woman using a cart to transport covered containers of prepared food to the points of sale (**practice to be encouraged**)

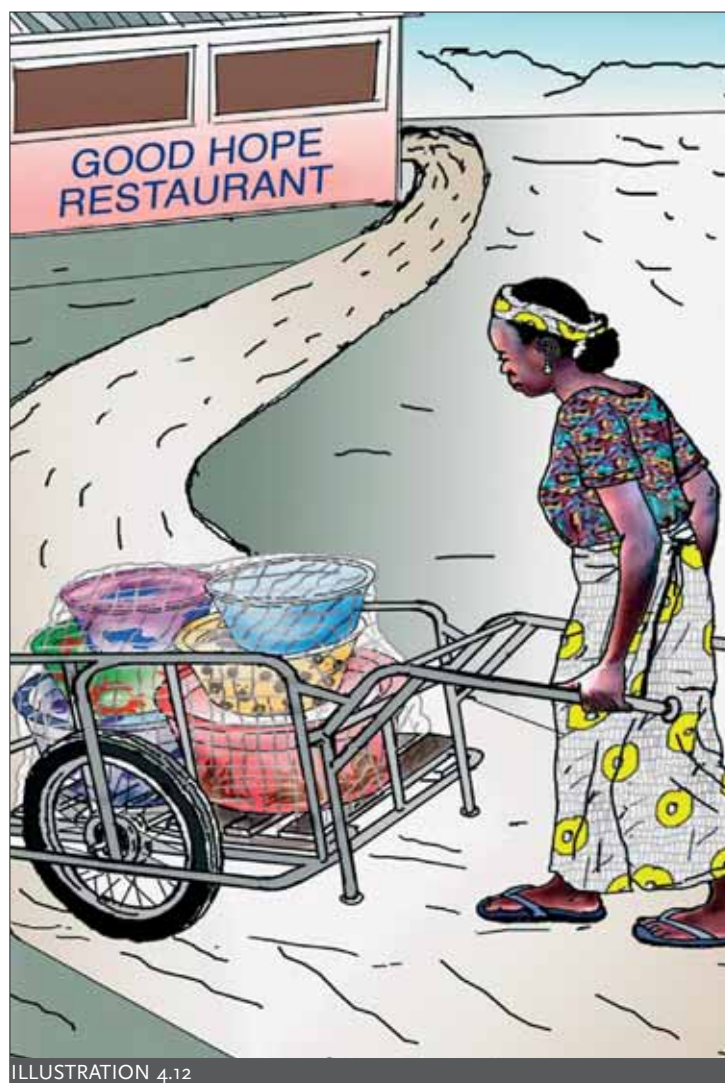

MESSAGE

When transporting prepared food, make sure it is protected against dirt by covering the containers.

DESCRIPTION

A woman food vendor simmering her sauce to avoid contamination and deterioration (practice to be encouraged).

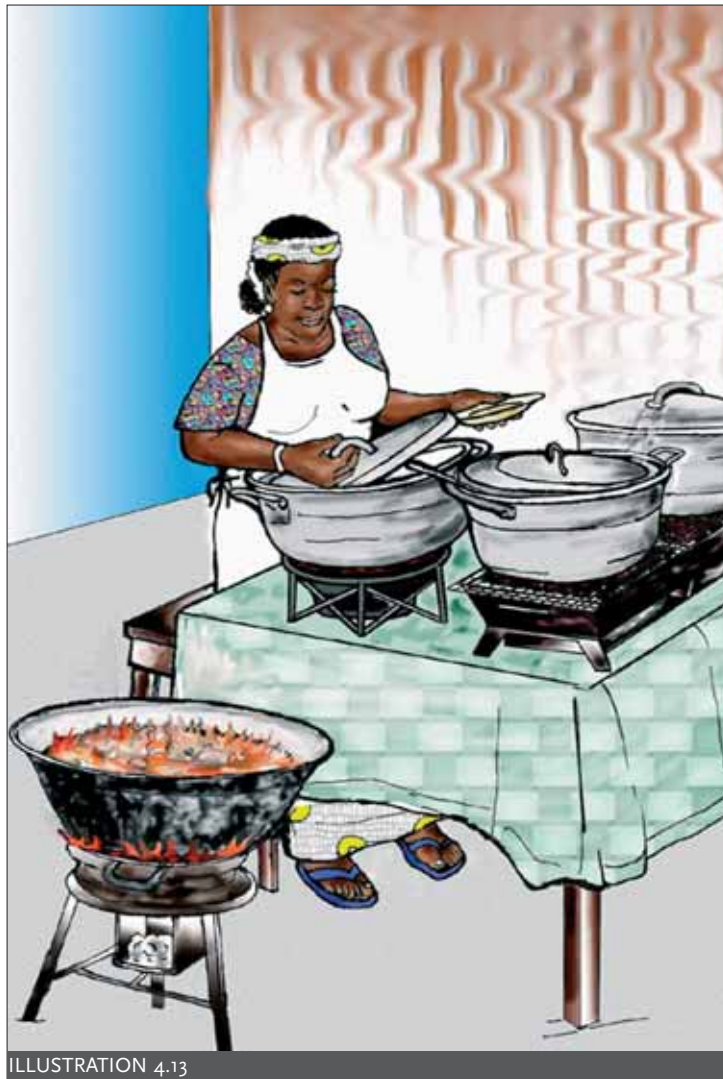

MESSAGE

Avoid contamination, deterioration and fermentation of prepared foods by keeping them hot.

DESCRIPTION

Before serving, a woman vendor helps a customer wash his hands with clean water
(practice to be encouraged)



ILLUSTRATION 4.14

MESSAGE

Wash your hands with clean water before and after meals.

DESCRIPTION

A customer washing his hands under the tap of a closed water tank. The dirty water is collected in a bowl under the tap (**practice to be encouraged**).

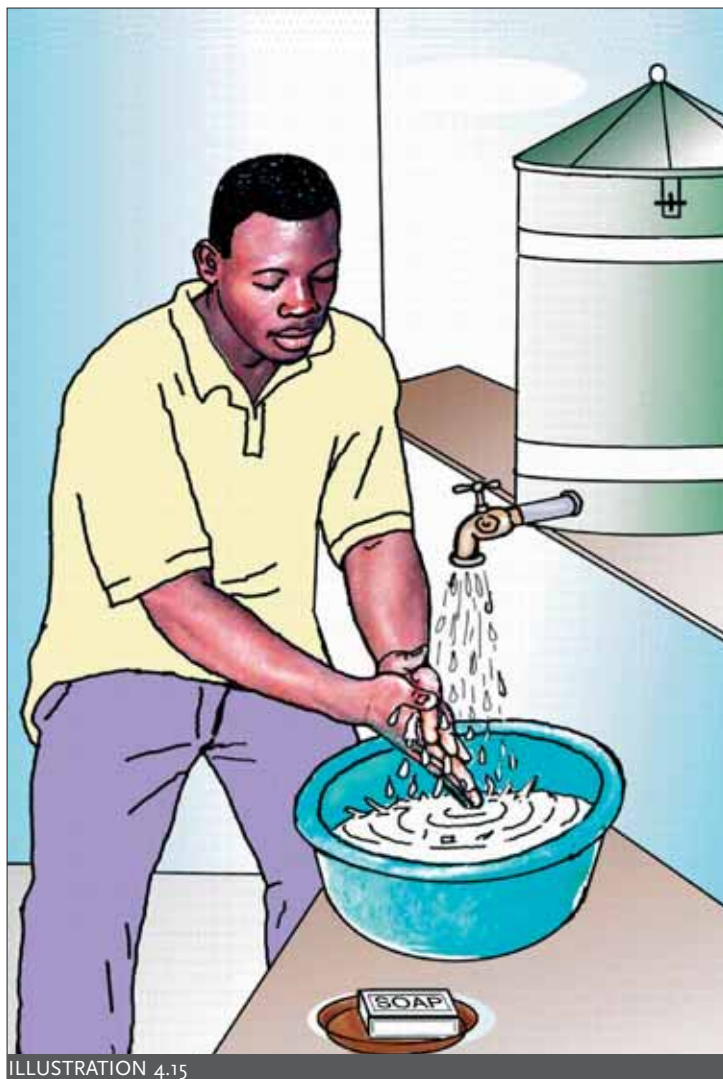

ILLUSTRATION 4.15

MESSAGE

Wash your hands under clean running water before and after meals.

DESCRIPTION

Several people washing their hands in the same bowl
(practice to be discouraged)



MESSAGE

Customers should not wash their hands at the same time, or one after the other, in the same bowl of water.

MODULE 5

HANDLING WATER IN STREET FOOD PREPARATION AND VENDING

PLAN

TRAINING OBJECTIVE	83
KEY WORDS	83
5.1 SUPPLY, USE AND HANDLING OF CLEAN WATER	84
A. Types and quality of water supply sources	84
B. Availability and use of clean water in street food preparation and vending premises	85
C. Managing clean water	85
5.2 WATER HAZARD	87
A. Managing wastewater	87
B. Dirty water and disease	87

TRAINING OBJECTIVE

Of all the potential sources of food contamination, one is prominent in causing health problems. That is water, which is too often of unknown or neglected sanitary quality and not always available in sufficient quantity. Yet, good hygiene requires abundant use of water for the frequent washing of hands, dishes, premises, raw materials and so forth. After constant recycling and reutilization for different purposes, even water that started clean can end up with a high microbial load that poses the risk of serious contamination.

The objective of this module is to familiarize trainees with the basic notions of hygiene in water management for the preparation and sale of street food.

On completion of this module, street food handlers should:

- know the types and quality of water supply sources associated with street food preparation;
- be familiar with methods and practices for keeping water clean;
- be familiar with practical methods of handling wastewater;
- know the different channels of food contamination from water and understand the basic notions of the water hazard.

KEY WORDS

Clean water – Disinfection – Fauna – Flora – Contamination – Water hazard – Bacteria – Wastewater

5.1. SUPPLY, USE AND HANDLING OF CLEAN WATER

Clean water is colourless, odourless and insipid. It is agreeable to taste and smell and can be drunk safely. Only (clean) water meeting WHO standards should be used when handling and processing food. Clean water should be used whenever necessary to avoid food contamination. The source of water supply is crucial to food vendors/handlers as it determines the quality of water at origin (clean or not).

A. TYPES AND QUALITY OF WATER SUPPLY SOURCES

There are two major types of water supply source: surface water and groundwater.

A.1. Main types of water supply source:

▶ Surface water

Surface water is water from a watercourse (lake, pond, basin, stream, river) and is subject to contamination. It is water that animals drink and where children sometimes paddle. Its banks are used for defecation and are covered with heaps of decomposing leaves.

▶ Groundwater

This is aquifer water which exists in two categories:

- in shallow aquifers or wells lying close to the surface of the ground (tens of metres), poorly protected and therefore exposed to biological contamination;
- in deep aquifers hundreds of metres below ground level and resting on deep impermeable layers of clay. Rainwater filters through several layers of earth before reaching the aquifer.

The water of deep aquifers is generally safe. In the case of thermal springs, it can be very hot, as high as 60°C.

A.2. The characteristics of the water

The characteristics of the water largely depend on its origin, but also on the facilities for its use. Thus, in the case of surface wells, facilities such as protection walls, clean scooping buckets and separation from latrines and wastewater provide a water of acceptable quality.

Such precautions also apply to water from deep wells. On the other hand, unprotected surface water is generally poor in quality because affected by various forms of contamination.

A.3. Contamination of water sources

Water sources can be polluted by industrial or domestic wastewater, pesticides or sewage without the user knowing. They therefore need to be protected against all types of contamination, whether microbial, parasitic, physical or chemical.

It is important that local authorities provide populations with clean water sources, in particular through effective off-take. Local populations should get their water from guaranteed sources. (Illustrations 5.1, 5.2, 5.3 and 5.4).

B. AVAILABILITY AND USE OF CLEAN WATER IN STREET FOOD PREPARATION AND VENDING PREMISES

One of the major problems in Africa is the inadequate supply of clean water in rural, and urban and periurban areas for direct consumption, food preparation, cleaning of utensils and personal hygiene.

ne. Many street food operators have to use water from wells or rivers, or rainwater. Even where water is not contaminated by industrial pollutants, it is often contaminated by faecal microbes.

And in some areas supplied with clean water, many food handlers contaminate that water by using it inappropriately:

- water for direct customer consumption (drinking water) and for food preparation and beverages is kept in containers that are uncovered, unclean or difficult to wash;
- water for washing up is used several times over and ends up with an excessive physical and microbial load that makes the washing useless.

Thus, water is a major source of potential contamination of street food in Africa, either because of poor quality at origin or because subsequently dirtied and misused.

C. MANAGING CLEAN WATER

The most serious problem is the microbial contamination of water, which can cause serious disease. Immediate action is therefore needed to treat the water, which is done in different stages: 1) decantation, 2) filtration, 3) disinfection. Preventive measures to restrict or eliminate the causes of such contamination are also needed.

C.1. Disinfecting water

Disinfecting water serves to destroy or deter harmful microbes. This can be done by physical means (decantation, slow filtration through a fine cloth, slow filtration through sand, boiling, solar disinfection) and/or by chemical means. Chlorine is the disinfectant most commonly used to destroy bacteria in the water. There are several ways of disinfecting water with chlorine in rural or periurban areas not supplied with industrially treated water.

- ▶ Disinfection of clear water:
 - one drop of chlorine bleach per litre of water;
 - one and a half capsules, or about 4 ml of chlorine bleach for 100 litres of water.
- ▶ Disinfection of decanted water:
 - three drops of chlorine bleach per litre of water;
 - one and a half capsules, or about 4 ml of chlorine bleach for 60 litres of water.

LEARN MORE

Disinfection of well water by continuous chlorination of the water:

The process involves the continuous use of chlorine to disinfect well water. This is done by placing a slow-release dispenser in the well to maintain a residual chlorine level for two to three weeks. The slow-release dispenser is placed in the well by specialists.

C.2. Preventive measures

These measures serve to protect the water source and collected water from contamination from carriage, through storage, to use. It is important:

- to use clean covered containers to carry and store water and clean vessels for drinking;
- to wash hands with soap and water before contact with drinking water.

C.3. Equipping the water sources

The water source amenities should prevent water stagnation that could encourage fauna and flora harmful to aquifer and water users. Recommended amenities include:

- a protection wall with rim and cover;
- a drainage channel;
- a sanitary base to prevent the accumulation of mud (**Illustration 5.4**).

GOLDEN RULES

The quality of well water is protected by:

- building a protection wall with rim to keep animals away;
- placing a cover to prevent contamination from dust and insects;
- digging a drainage channel for spillage or water trickling from buckets;
- incorporating a base on which to rest containers and avoid contamination from the ground;

The following hygiene measures should be observed to maintain the quality of the drinking water:

- use clean containers with covers for water carriage and storage;
- prevent foreign matter such as leaves and branches entering the water during carriage to place of use;
- wash hands with soap and water before contact with drinking water;
- use clean drinking vessels.

GOLDEN RULES

The following actions are needed as protection against water-borne diseases:

- collect clean water and observe the rules and practices of personal and collective hygiene;
- build latrines far from water points;
- wash hands after each defecation;
- eliminate anything that attracts flies or other forms of life conducive to microbial growth by:
 - destroying cans and other objects that serve as breeding grounds;
 - covering all water tanks;
 - building protection walls around large wells against contamination from animals.

5.2. WATER HAZARD

A. MANAGING WASTEWATER

Domestic wastewater is from cooking, washing and showering. Such water can seriously contaminate food and needs to be hygienically removed in specially designed sanitary structures: latrines, septic tanks, drainage sumps, pools, drainage pits. It should not be left to accumulate in or near areas where food is handled and stored.

For wastewater disposal, street food facilities should:

- be equipped with one or more systems of disposal of liquid waste. These can be communal or individual but need to be approved by the competent authority;
- keep their disposal system in good order.

B. DIRTY WATER AND DISEASE

Contaminated water poses serious health risks, especially in rural areas where unclean water is often drunk to quench thirst. Water contaminated with faecal or urinary excretion contains pathogens that cause a range of water-borne faecal infections. Water can be contaminated close to the point of collection, during carriage from collection to consumer, or during storage.

There are four groups of disease associated with water:

- disease from the ingestion of water contaminated with faecal matter such as: cholera, typhoid and paratyphoid fever, infectious hepatitis, amoebiasis, bacillary dysentery, gastroenteritis;
- disease from parasites in water, such as dracunculosis or Guinea worm, intestinal or vesicle schistosomiasis;
- disease associated with water shortage, such as yaws and scabies resulting from a lack of personal hygiene;
- disease transmitted by vectors linked to water such as: malaria, yellow fever, river blindness.

The transmission of microbes varies according to their form of life. There are three types: the short direct method, the long direct method and the indirect method. Water can also be the bree-

ding ground for insect vectors of disease, such as mosquitoes which carry parasitic or viral disease, including yellow fever, lymphatic filariasis, better known as elephantiasis, and malaria. Mosquitoes breed in temporary or permanent pools of water exposed or not to the sun.

LEARN MORE

CHANNELS OF MICROBIAL CONTAMINATION

- The short direct channel: microbes (bacteria, viruses) or parasites (amoeba, pinworms) present in eliminated faecal matter are direct contaminants for humans. Infection is oral, by hand, by vegetable eaten raw or by contaminated water (case of bacteria, viruses and parasites).
- The long direct channel: eggs or larvae of these parasites only acquire their contamination property after a period outside the human organism. Infection is either oral by consuming contaminated water or raw fruit or vegetable (case of roundworm and whipworm) or by walking bare foot or bathing in fresh water (case of hookworm and eelworm).
- The indirect channel: parasites, after evacuation from the human organism that hosted them as eggs or larvae, only acquire their contamination potential after obligatory passage through intermediary hosts. Some of these hosts live in aquatic environments. This occurs with schistosome (bilharzia) whose intermediary host is a mollusc and the Medina worm (Guinea worm) whose intermediary host is a small freshwater crustacean known as Cyclops.

GOLDEN RULES

- ▶ Water is vital for life, but can also be a source of disease and death when not of good quality.
- ▶ Water is contaminated by living beings (or by eggs of living beings). They are so small they cannot be seen with the naked eye. These are microorganisms.
- ▶ Water can vector these many microbes responsible for disease. Microbes can be:
 - bacteria: choleric vibrio (cholera), shigella (dysentery, bacillosis), salmonella (typhoid fever);
 - viruses: hepatitis;
 - protozoa: amoebic dysentery;
 - worms: roundworm, hookworm, eelworm, Guinea worm.

Exercise 5

Microbes are all around us and can spread disease through various channels:

1. Name some of those channels.
2. How can we limit the spread of microbes?

DESCRIPTION

A woman collecting water from a high-risk source of contamination (watercourse) (practice to be discouraged).

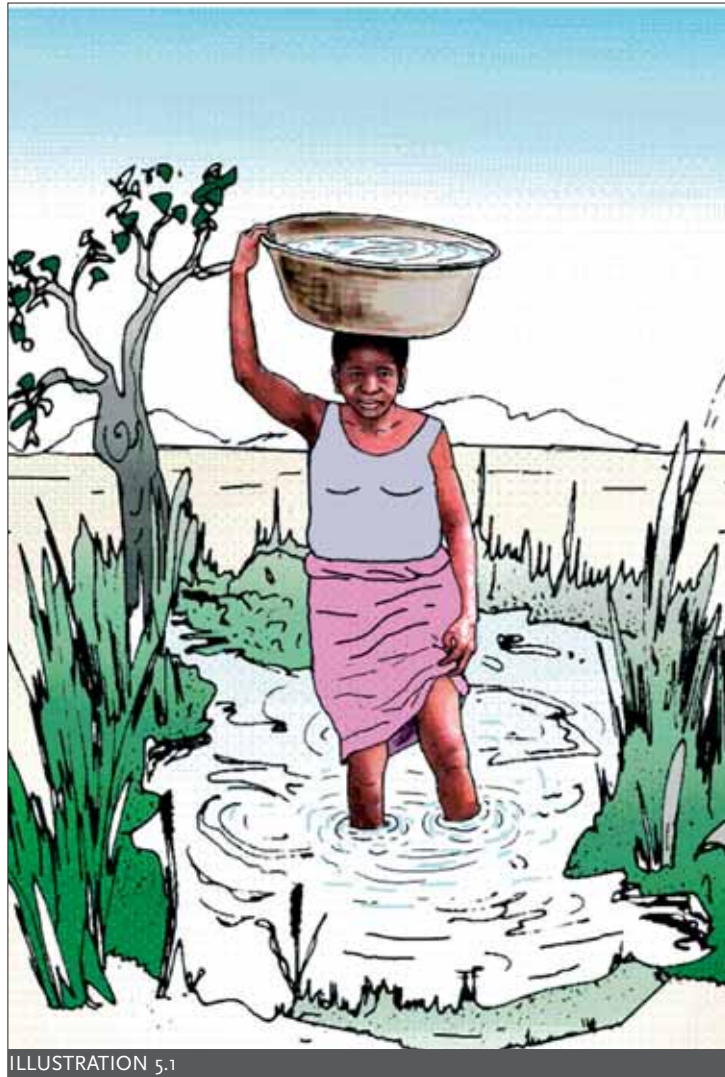

MESSAGE

I avoid collecting water for consumption from high-risk sources of contamination.

DESCRIPTION

A woman collecting drinking water from a clean source: a standpipe connected to the grid (**practice to be encouraged**).

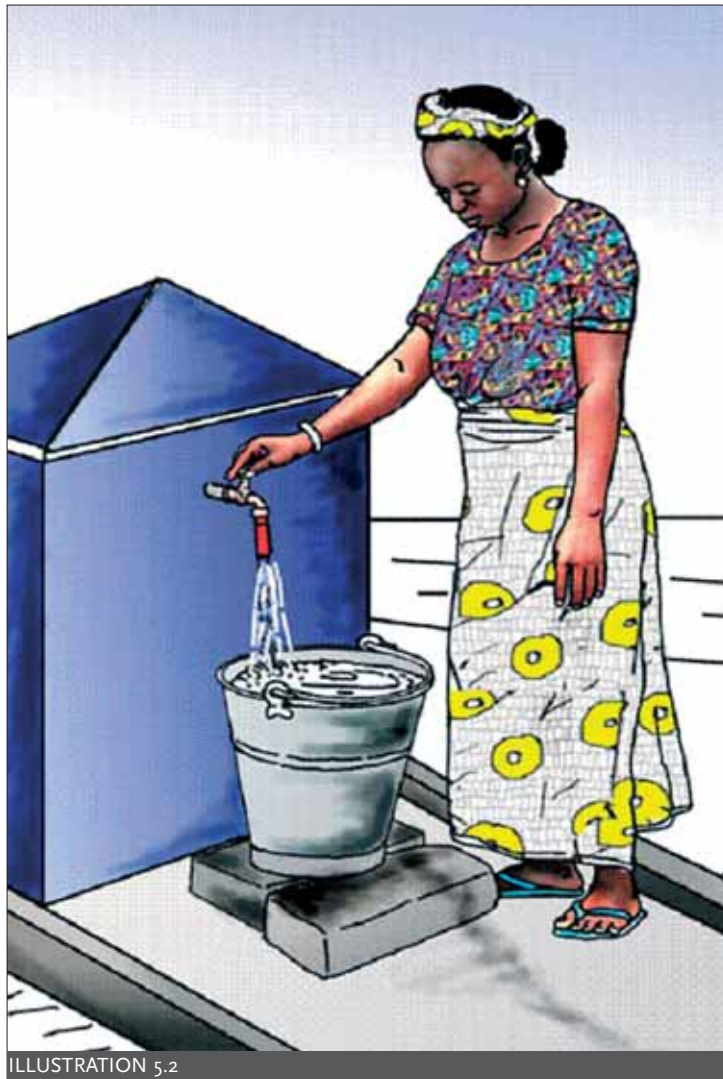

MESSAGE

I fetch my drinking water from safe sources such as the grid.

DESCRIPTION

A woman collecting drinking water from a clean source (well with rim and cover)
(practice to be encouraged).



ILLUSTRATION 5.3

MESSAGE

I collect my drinking water from safe sources such as wells with rim and cover.

DESCRIPTION

A well with rim and cover (practice to be encouraged)



MESSAGE

Always place your wells far from latrines and keep them covered against contamination.

DESCRIPTION

A woman serving drinking water from a jug (practice to be encouraged).



ILLUSTRATION 5.5

MESSAGE

I provide my customers with drinking water in an appropriate container.

DESCRIPTION

Good management of drinking water at a food outlet means keeping it in a large covered recipient and serving it with a clean beaker (**practice to be encouraged**).

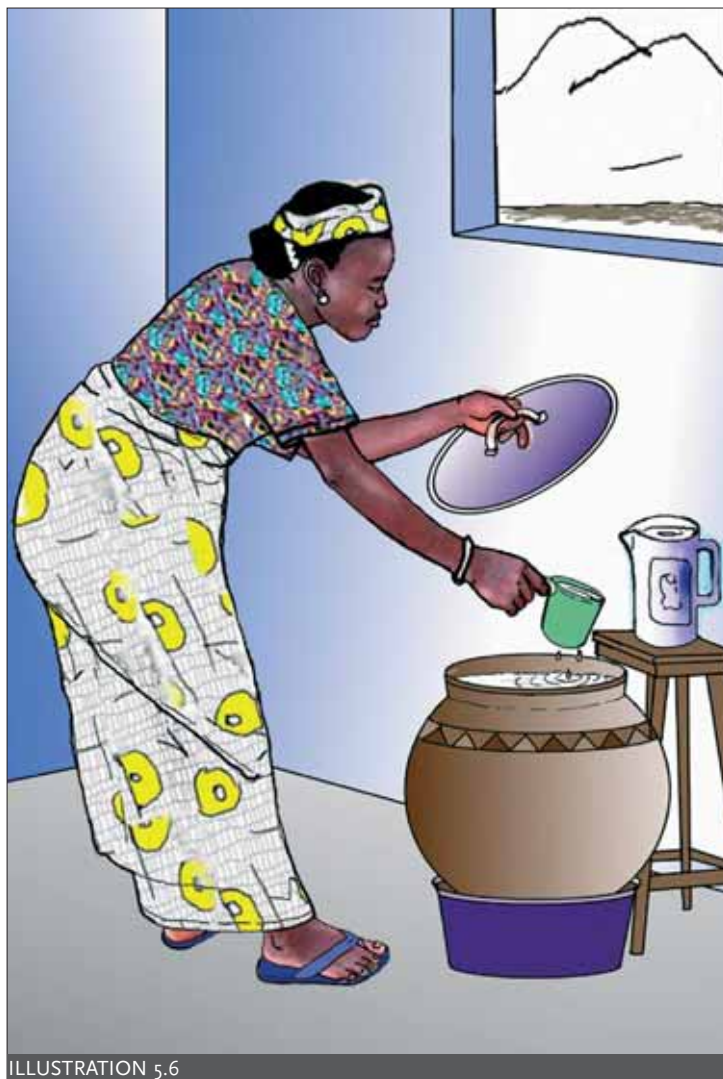

ILLUSTRATION 5.6

MESSAGE

I always cover my drinking water and serve it with a clean beaker.

MODULE 6

REGULATION AND CONTROL OF STREET FOOD QUALITY

PLAN

TRAINING OBJECTIVE	97
KEY WORDS	97
6.1 STREET FOOD REGULATORY TEXTS	97
6.2 APPLICATION OF HACCP PRINCIPLES TO ANALYSE STREET FOOD HAZARDS	98
A. Phase of hazard analysis	98
A.1. Establishment of a detailed preparation diagram	99
A.2. Validation of the preparation diagram	99
A.3. Analysis of actual risks	99
B. Phase of determination of critical points and thresholds	101
C. Phase of surveillance and implementation of corrective actions	101
D. Phase of verification	101
6.3 EXAMPLES OF CRITICAL CONTROL POINTS IN STREET FOOD	102
A. Water	103
B. Raw materials and ingredients	104
C. Work materials and packaging	106
D. Food preparation, sale, storage and preservation operations	106
E. Vending practices and conditions	106
F. Premises	106
G. Food handler	107

TRAINING OBJECTIVE

The objective of this module is to familiarize street food handlers with the rules governing the sector and the basic notions to determine critical points in the chain of street food production, sale and consumption.

On completion of this module, the street food operators should:

- know the rules applying to the street food sector;
- know the factors of risk associated with street food and the critical points;
- understand the need to adopt preventive measures against the risk of contamination and to observe the rules governing the street food sector.

KEY WORDS

Contamination – Hazard – Disinfection – HACCP – Cleaning – Pesticides – Regulations

6.1. STREET FOOD REGULATORY TEXTS

Street food regulation and control varies widely from one country to another. Some countries have adopted legislation to regulate the preparation and sale of food but fail to consider the specific characteristics of street food. Other countries have no general regulation and street food control exists in the form of repression of offences and ad hoc regulatory provisions determined by local authorities or ministries as problems occur. Whatever the situation, it is important to note that street food should observe the fundamental regulatory principles that govern food in general. In particular, it should not harm consumers. But the real problem is applying the regulations, whatever these may be.

Where they exist, legal texts governing street food generally cover the following key aspects:

- requirements for authorization to exercise food production and sale activities;
- composition and presentation of food products;
- offences and penalties;
- institutions and officials responsible for food surveillance and control.

One of the basic principles in existing legal texts is that food production and sale is subject to prior authorization and official control.

Vendors/handlers have to complete administrative procedures and apply to the authorities for a vending site and permit. The application includes a medical certificate from the medical services approved by the Ministry of Public Health, evidence of vaccination against typhoid fever and cholera, and the results of medical and biological tests, including:

- analysis of faeces;
- analysis of urine and blood;
- analysis of sputum;
- skin test reaction (tuberculosis);
- an x-ray.

These tests are required every twelve months. Vendor/handlers need to be free of contagious disease, including tuberculosis. In some countries like Senegal, they also need a sanitary certificate from the same services confirming that their food production and sale premises are clean and conform with regulations.

The penalties specified in legal texts include:

- prison sentences;
- fixed fines that vary considerably from one country to another.

Depending on the case, infringement is punished by one or both of these penalties. Prison sentences are often for a few days only.

Operators have to pay daily fees, which vary according to the country. On the other hand, most street food operators do not pay income tax as they operate in the informal sector.

6.2. APPLICATION OF HACCP PRINCIPLES TO ANALYSE STREET FOOD HAZARDS

The HACCP (Hazard Analysis Critical Control Point) system is a general method applicable to all human activity and especially agrifood enterprises producing food for consumption. The HACCP system is a preventive approach to control the production and distribution of food and to make sure it is safe.

The aim of the HACCP system is to assure compliance with hygiene rules and the existence of regular, effective auto-control in street food preparation and sale activities in order to ensure food safety and protect consumer health. The system was developed for industry. It imposes systematic monitoring and recording of all activities. However, its principles can be adapted to the street food sector. Its great advantage is that it helps operators identify critical points in their preparation process and to concentrate on those points to avert contamination. Another advantage is that it helps inspectors grade the intensity of inspection for each stage of preparation, making inspection more effective.

Training and awareness raising for street food players should therefore focus on good hygiene practices (GHPs) and good manufacturing practices (GMPs). Applying the principles of the HACCP system to street food alerts operators to the need to prevent, to monitor potential hazards and to correct anomalies in four phases: hazard analysis, critical control point, monitoring and evaluation.

A. HAZARD ANALYSIS

A hazard is anything that threatens or compromises the safety or existence of a person or thing. It is characterized by:

- the nature of contamination or germs likely to be encountered in or on a food; each germ or group of germs is an agent of specific conditions and constitutes a hazard;
- seriousness, which depends on effects or expression and varies according to the analytical perspective: public health (infections, food poisoning and toxic infections) or commercial implications;
- frequency of manifestation.

The hazard analysis phase begins with a clear definition of the hazards sought. It requires:

A.1. A detailed flow diagram

This is a sequence of all preparatory stages. Each stage is broken down into its multiple constituent operations. This facilitates understanding and analysis of each stage or operation.

A.2. Validation of the flow diagram

The flow diagram needs to be confirmed by on-site inspection and compared with actual work operations. This ensures that all production operations have been identified.

A.3. Analysis of the hazards as such

This needs to be supported by on-site inspection based on a “model” flow diagram adapted to all vendors/handlers of individual food product. It entails:

- ▶ identifying basic products of plant origin (vegetables, maize, sorghum, yam, cassava, etc.) or animal origin (meat, poultry, game, etc.), ingredients, and products that are hazardous or sensitive because they:
 - contain toxic substances;
 - contain microorganisms that are pathogenic and/or responsible for spoilage;
 - can activate or maintain microbial growth (composition, physical and chemical properties, packaging, etc.).
- ▶ determining the nature, biology and ecology of microorganisms;
- ▶ determining the consequences of variability of primary product on the quality of prepared food, its safety and the preparatory method used;
- ▶ determining the effects of surroundings and equipment (cooking appliances and utensils) on:
 - microbial contamination;
 - other risks (chemical, physical, etc.).
- ▶ determining the possibilities of survival and multiplication of microorganisms during the stages of food preparation, handling and sale.
- ▶ determining the responsibilities of street food handlers for contamination of food products. There is often regrettably:
 - an absence of training in personal hygiene and sanitary food preparation;
 - a low level of education among food handlers;
 - a failure to observe the basic rules of food hygiene;
 - a marked difference in personal hygiene and cleanliness of clothing among food handlers;
 - a high turnover of food handlers.
- ▶ identifying interactions between these elements.

This hazard analysis phase generates a list of hazards in each preparation stage and identifies the different hazard points. These are then assessed in terms of cause, consequence and gravity, as well as likelihood and shape of materialization. Some listed hazards are more serious than others. They are categorized according to:

- frequency and impact on consumer health;
- potential for control through good hygiene practices;
- nature of preparation process implemented: the possibility of subsequently eliminating the hazard during product preparation (e.g. long and prolonged cooking at the end of the preparation process serves to eliminate the bacterial hazard).

Example of flow diagram

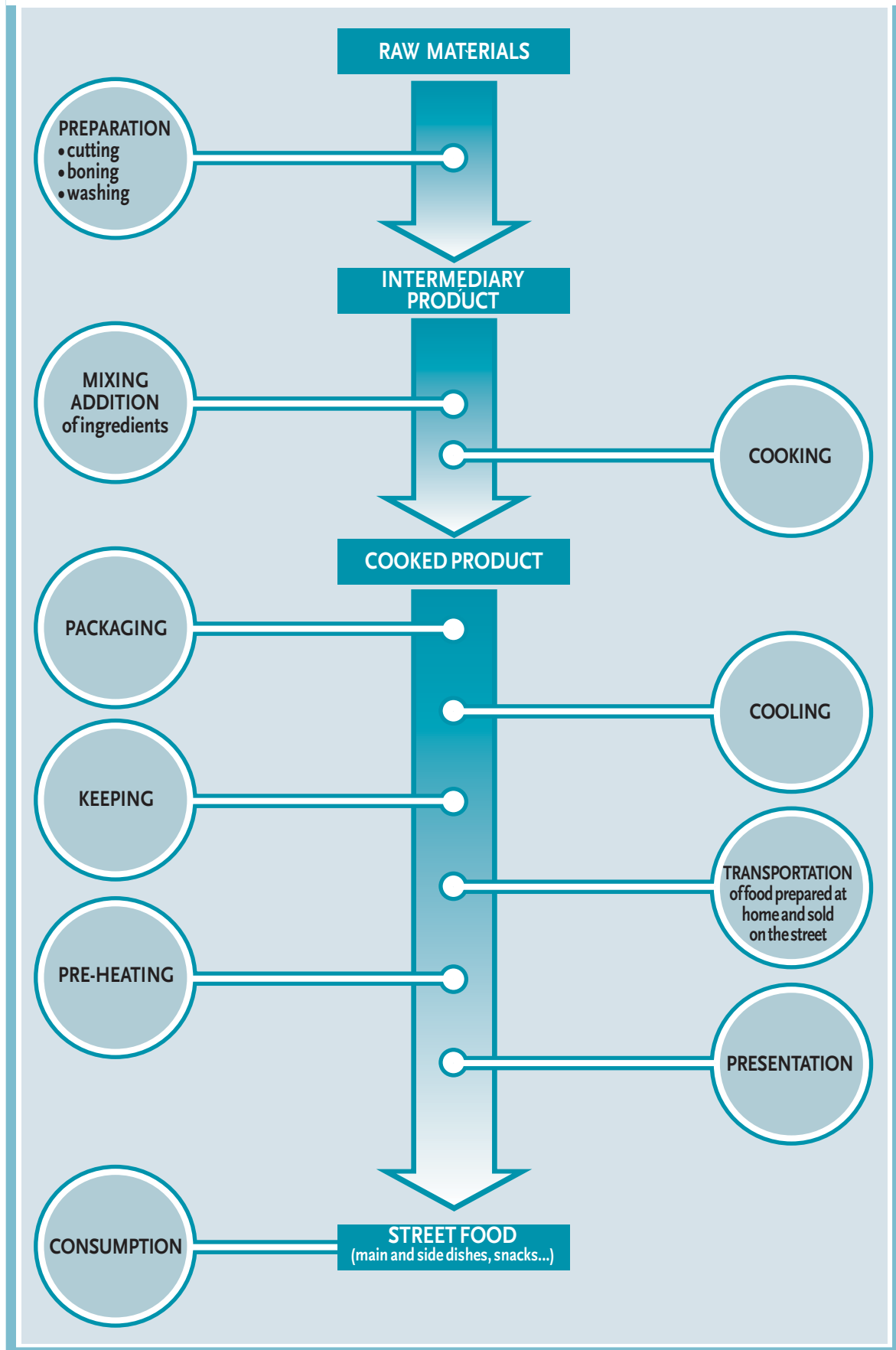

B. DETERMINATION OF CRITICAL POINTS AND THRESHOLDS

A critical point is a point where a system can be introduced to reduce a hazard by calculated proportion, e.g. procedures to eliminate or reduce the presence of microorganisms (treatment by heat, cold, adjustment of pH, water activity – aw). Controlling hazards means controlling critical points so that resulting contamination is below a threshold (sanitary criteria, market standards). However, sometimes several critical points need to be controlled (processing and thermalization, etc.) to control a hazard.

The critical control point phase produces a formal selection of control options, in the form of rigorous specifications and operating modalities that are as detailed and precise as necessary for each critical point (cook at a certain temperature for a certain period of time, etc...).

C. MONITORING AND IMPLEMENTATION OF CORRECTIVE ACTIONS

With regard to the preparation and sale of street food, monitoring means ensuring the food preparation meets the criteria set by the inspection and sanitary control services during the preliminary study (through microbiological or toxicological analysis).

Depending on their expertise, food handlers immediately apply corrective actions when an operation becomes unsatisfactory. Such corrective actions are often traditional practices that are handed down generations and that determine culinary success.

D. VERIFICATION

This is equivalent to an audit of the HACCP system to ensure the safety of prepared food. Verification serves to determine the need for actions to improve food preparation conditions or actions to correct the HACCP system put in place. This level could help forge a new relationship between food handler and technical agent, especially national sanitary inspector responsible for hygiene in general, and food hygiene in particular.

LEARN MORE

There are two types of audit: implementation audit and situation audit whose principal objectives, scope and methodology are summarized below:

TYPE OF AUDIT	SPECIFIC “HYGIENE” OBJECTIVES	SCOPE	GENERAL METHODOLOGY
<p>Implementation audit</p> <ul style="list-style-type: none"> ● Conformity of implementation with requisite conditions ● Conformity of food with requisite characteristics 	<ul style="list-style-type: none"> ● Identify weak points or shortcomings in relation to official regulatory provisions considered as reference provisions (or expanded to codes of good practices or to specific contractual requirements) 	<ul style="list-style-type: none"> ● Totality or part of the elements covered by the regulation (and codes of good practices and other requirements) 	<ul style="list-style-type: none"> ● Inspection
<p>Situation audit</p> <ul style="list-style-type: none"> ● Description of activities and techniques ● Analysis of their relevance and effectiveness 	<ul style="list-style-type: none"> ● Effectiveness with which an organized system takes hygiene into account ● Validity of analyses conducted and measures taken 	<ul style="list-style-type: none"> ● Plan (or programme) of hygiene assurance ● Objectives, work instructions, control programme, records, verification of identified hazard points 	<ul style="list-style-type: none"> ● HACCP approach Inspection based on regulatory provisions

6.3. EXAMPLES OF CRITICAL CONTROL POINTS IN STREET FOOD

Street food is exposed to different contamination hazards (microbial, parasitic, physical, chemical) that sometimes make that food dangerous for consumers; hence the need to assess and control potential hazards that could undermine food sanitary quality. Because of its rigour and systematic nature, the hazard analysis method is useful for adapting the implementation of required hygiene measures and for specifying critical points. Unhygienic conditions and practices that are conducive to risk apply to operators, consumers, street food premises and supplies and processed materials.

The hazards associated with food are many and various:

- unclean water;
- contaminated or poorly washed raw materials;
- dirty work materials;
- preparation and sale of food in unhygienic or inappropriate surroundings;
- use of unclean packaging;
- failure to protect food from external contamination;
- poor conditions of storage and preservation;
- use of a small number of pots and plates;
- unsatisfactory operator hygiene and health
- other unhygienic traits and practices of operators and consumers (poor personal hygiene, inappropriate clothing, improper conduct during food preparation, sale and consumption, etc.). The risks therefore exist at several levels.

The following chart presents the microbial dangers and preventive measures for pre-cooked foods.

Chart of microbial hazards and preventive measures for precooked foods

OPERATIONS	HAZARD POINTS	PREVENTIVE HYGIENE MEASURES	CRITICAL POINTS AND CONTROL PROCEDURES	CONTROL OF PROCEDURES	HAZARDS
Reception of raw materials	GI = RM	<ul style="list-style-type: none"> Sorting 		<ul style="list-style-type: none"> Sorting method 	<i>All germs</i>
Storage	GI = MT . L X = Eq . Me	<ul style="list-style-type: none"> Separation of RM Maintenance 	<ul style="list-style-type: none"> Temperature Duration of storage 	<ul style="list-style-type: none"> 3°C – 7 j 	<i>Pseudomonas</i>
Preparation	GI = RM.L.Eq X = Me	<ul style="list-style-type: none"> Cleaning Disinfecting Personal hygiene 	Correct dosage of acids	PH 4 <ul style="list-style-type: none"> Protocol for cleaning and disinfecting 	<i>Pathogenic germs</i>
Cooking			<ul style="list-style-type: none"> Temperature Duration 	<ul style="list-style-type: none"> 75°C - 30mn or boiling 30 mins 	<i>Pathogenic germs</i>
Portioning and packaging	GI = RM.L.En	<ul style="list-style-type: none"> Cleaning Disinfecting Personal hygiene 	<ul style="list-style-type: none"> Clean room 	<ul style="list-style-type: none"> Speed of laminar flows Personal and clothing hygiene 	<i>Psychrophilic germs</i>
Cooling	X = Me		Speed		<i>Thermophilic germs</i>
Storage	X = Me . Eq		<ul style="list-style-type: none"> Temperature Duration 		<i>Pathogenic and psychrophilic germs</i>
Dispatch	X = Me	<ul style="list-style-type: none"> Under cold regime 	Anticipate the changing condition of precooked food		<i>All germs</i>

LEGEND

GI : Germ input	RM : Raw material	Me : Method	En : Environment
X : Multiplication	L : Labour	Eq : Equipment	

A. WATER

Hazards often arise from a lack of clean water for direct consumption, food preparation, washing of utensils or personal hygiene. In some areas operators have to use well or river water that is often contaminated, especially with bacteria. In areas with good clean water, food handlers often use that water inappropriately, resulting in its contamination:

- water for customer consumption or for the preparation of food and beverages is often kept in containers that are uncovered, dirty or difficult to clean;
- water for washing dishes is rarely hot. It is used several times and ends up with a high physical and microbial load.

Water is therefore a main source of contamination of street food. Agents of contamination are essentially microbial: coliforms, faecal streptococci, etc.

B. RAW MATERIALS AND INGREDIENTS

Purchases

When purchasing raw materials and ingredients, it is important to check the cleanliness of point of purchase and the appearance of the produce. Avoid goods that are unusually cheap as these are often substandard. For a constant supply of quality produce, it is important to build a regular network of suppliers who understand and respect food hygiene criteria. For processed goods, it is important to inspect the products, to check the labelling of raw materials and mandatory specifications (see Module 2, Section 2.1.D), in particular the best-before and/or use-by dates and storage conditions.

Controlling temperature at reception of chilled or frozen products is possible and is recommended where the means exist.

LEARN MORE	
Controlling temperature at reception	
PRODUCTS	RECOMMENDED TEMPERATURES
Frozen	-18°C
Fresh fish	+2°C, under ice
Raw minced meat	+2°C
Raw or other meat, poultry, rabbit, egg products, etc.	+4°C
Yoghurts, fresh cheese, cream, milk, butter, etc.	+6°C

Storage on reception

A number of principles should be observed to avoid contamination:

ORIGIN	PREVENTIVE MEASURES	TARGET	CORRECTIVE ACTION
Cross-contamination	<i>Separate merchandise according to origin (vegetable or animal)</i>	<i>no mixing in cold rooms</i>	<ul style="list-style-type: none"> • <i>check the distribution of merchandise</i> • <i>increase the number of cold rooms</i> • <i>unpack everything</i>
Damaged goods	<i>Make sure the merchandise is properly protected (wrap, cover, ...)</i>	<i>all the food products are protected</i>	<ul style="list-style-type: none"> • <i>protect the food</i> • <i>make personnel aware</i>
Contamination from the ground or cleaning operations	<i>Raised storage</i>	<i>no storage on the ground</i>	<ul style="list-style-type: none"> • <i>move the produce</i> • <i>make personnel aware</i>

Defrosting

Using frozen fish or meat requires special measures, particularly during defrosting which is a delicate phase when contamination can occur.

- ▶ Preventive measures:
 - restricted period of use after defrosting;
 - labelling of defrosting products specifying start of defrosting;
 - defrosting in a cold environment, or if possible direct cooking of the product.
- ▶ Target values:
 - note the expiry date of the product;
 - protect the produce;
 - do not defrost at ambient temperature;
 - temperature of defrosting area below or equal to 3°C.
- ▶ Tolerances:
 - defrosting under running cold water for fish;
 - temperature of defrosting area up to 9°C.

C. WORK MATERIALS AND PACKAGING

Unclean or poorly washed materials used for food preparation, preservation, storage and distribution contribute significantly to contamination. **The use of dirty work materials is strictly forbidden as this affects food hygiene and endangers consumer health.** The use of unclean packing materials (plant leaves, recycled boxes and bottles, newspaper, cement sacking) is a significant source of food contamination.

D. FOOD PREPARATION, SALE, STORAGE AND PRESERVATION OPERATIONS

Street food can also be contaminated by chemical agents such as lead (from water pipes, welded can seams or air pollution), mercury (detected especially in fishery products), pesticides (essentially from phytosanitary treatment), veterinary products and unauthorized additives. Whether introduced intentionally or inadvertently into street food, most of these chemical substances have proved to be toxic.

■ Preparation or sale of food in unsanitary surroundings:

When street food vendors/handlers set up their stalls in dusty surroundings close to piles of rubbish, wastewater discharge points and toilets that attract flies, mosquitoes, cockroaches, mice, etc., their products will inevitably be contaminated. The animals, insects and other impurities will act as vectors for an assortment of contamination agents.

■ Failure to protect food:

Flies and other insects infest the vending site and transmit microbes and parasites to unprotected food on display. Poor conditions of storage and preservation facilitate the growth of germs, contamination and food degradation.

Food vendors generally have no refrigerator or deep-freeze to keep their food. Also, many products are sold after insufficient cooking. Few vendors keep their food permanently hot (60 to 65°C) until sold.

E. VENDING PRACTICES AND CONDITIONS

Certain inappropriate practices are also sources of contamination of street food:

- the use of too few jugs to serve water;
- poor operator hygiene and health;
- dirty clothing, no apron and poor personal hygiene;
- other unhygienic operator and consumer practices: handling food with bare hands during preparation and sale, tasting food directly from the cooking pot or serving bowl, etc.

F. PREMISES

▶ Risks of contamination:

Appropriate, well designed premises help operators in their work, but this needs to be rigorously organized for best results and reduced risk of food contamination.

If food products are not handled in clean premises or if the premises are narrow and make observation of hygiene rules difficult, the risks of food contamination escalate.

▶ Cleaning and disinfecting the premises:

Food hygiene in the cooking area requires clean surface areas. The complete premises and

equipment can be contaminated by inoffensive or dangerous germs during the work period. It is essential to clean and disinfect the cooking area and equipment to prevent microbe breeding grounds.

▶ Preventive measures:

The food preparation area needs to follow two basic rules: separation of preparation activity by sector and a forward sequence. Clean food should never cross unclean food.

- Separation of preparation activity by sector: this means keeping clean sectors separate from unclean sectors. This rule serves to anticipate and thus prevent food contamination by averting the risk of microbial growth. Where distinct zones are not possible, there can be separation in time, in the sense that different operations are carried out at different times, interspaced by cleaning and disinfecting.
- Forward sequence: from reception to consumption, food should move forward into an increasingly clean environment. Clean food should not cross unclean food. Raw food should never come into contact with cooked food, including through utensils (cutting board...).

GOLDEN RULES

To reduce the risk of microbial contamination of food, it is important:

- to avoid crossing clean with unclean;
- to avoid moving products back into unclean areas;
- to store raw materials upstream from production areas;
- to adjust the organization of work to mitigate the constraints of non-conforming premises.

G. FOOD HANDLER

Health of the food handler

▶ The hazards:

Human beings naturally host a wealth of microbial flora on their skin and in the nose, mouth and digestive tract. This flora has inoffensive germs but also germs that are potentially harmful, known as pathogens. Persons carrying those germs can be continuously sick (infected eczema, etc.) or occasionally sick (whitlow, etc.) or may not display any visible symptoms (in which case they are healthy carriers, often releasing germs in a discontinuous and unpredictable manner).

Kitchen personnel can therefore be a primary source of food contamination through pathogenic germs.

▶ Preventive measures:

- for medical surveillance, a doctor's visit once a year is recommended;

- for the prevention of contagion: sick or injured persons (colds, wounds, burns, etc.) should stay away from food handlers; in the case of injury in cooking area, a waterproof bandage should be applied.

Personal hygiene of the food handler

▶ The hazards:

Poor personal hygiene can be a source of food contamination during handling, transmitted by hands, badly kept nails, hair or body hair.

▶ Preventive measures:

Frequent hand washing and bathing;

- hands should always be kept clean;
- no jewellery or watches should be worn in the cooking area;
- nails should be kept short and without varnish in the cooking area;
- regular visual inspection of all personnel.

Cleanliness of handler clothing

▶ The hazards:

Personal clothing (particularly shoes) are vectors of contamination from microorganisms brought into the work area.

▶ Preventive measures:

- use occupational work clothes;
- regularly inspect all personnel;
- carefully inform and sensitize personnel.

GOLDEN RULES

- Watches, bracelets and rings prevent the thorough cleaning of hands and forearms
- Assured food safety requires hand washing, which should become automatic.

Exercise 6

1. What actions and measures need to be taken before operating in the street food sector?
2. What are the main factors of risk that facilitate contamination?
3. What are the critical control points in the HACCP system applied to street food? Illustrate with a precise food example.

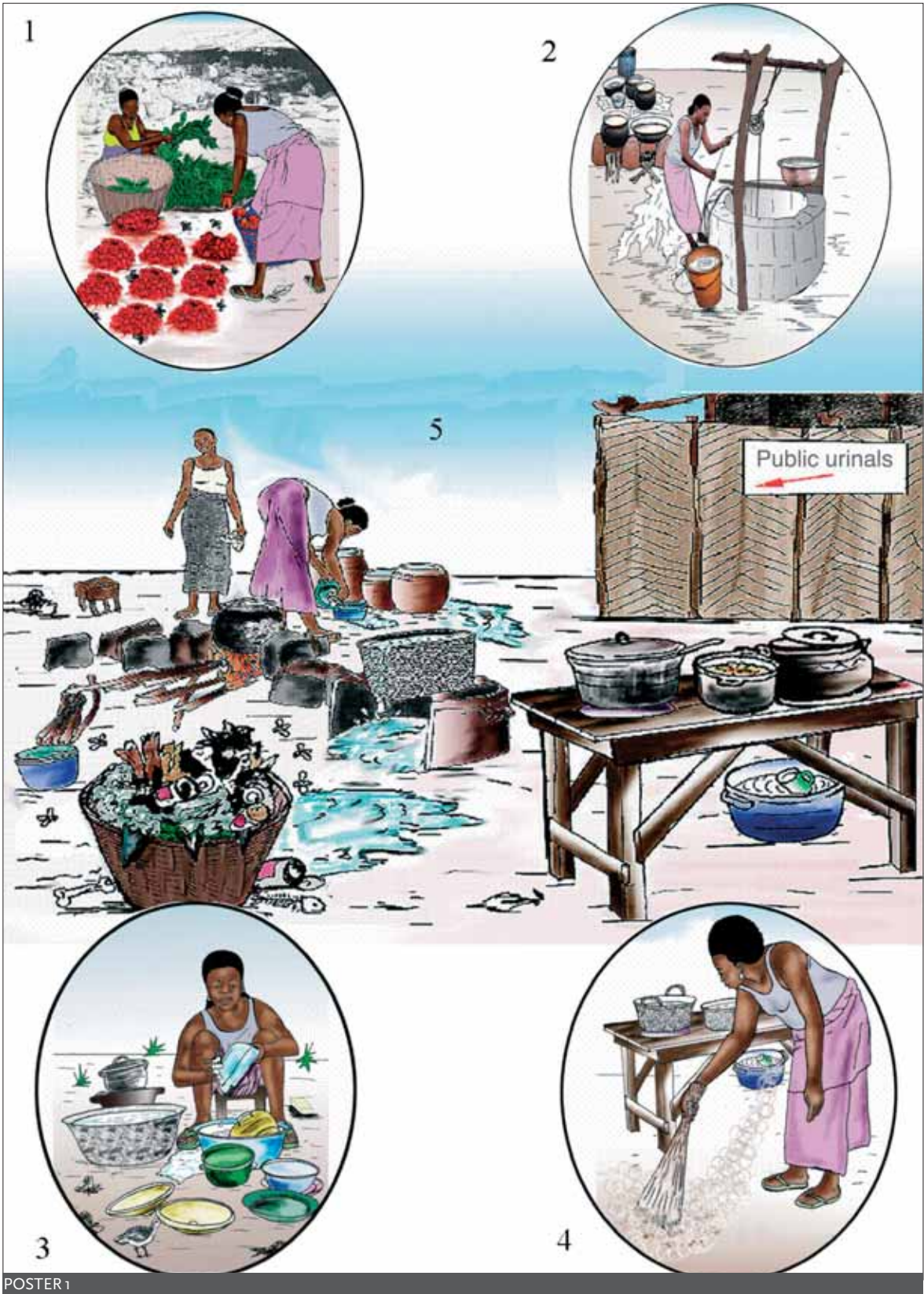

POSTER 1

**HYGIENE OF FOOD PREPARATION AND SALE POINTS:
UNSANITARY PRODUCTION**

Handling food in unsanitary surroundings is a source of microbial contamination.
(practice to be discouraged)

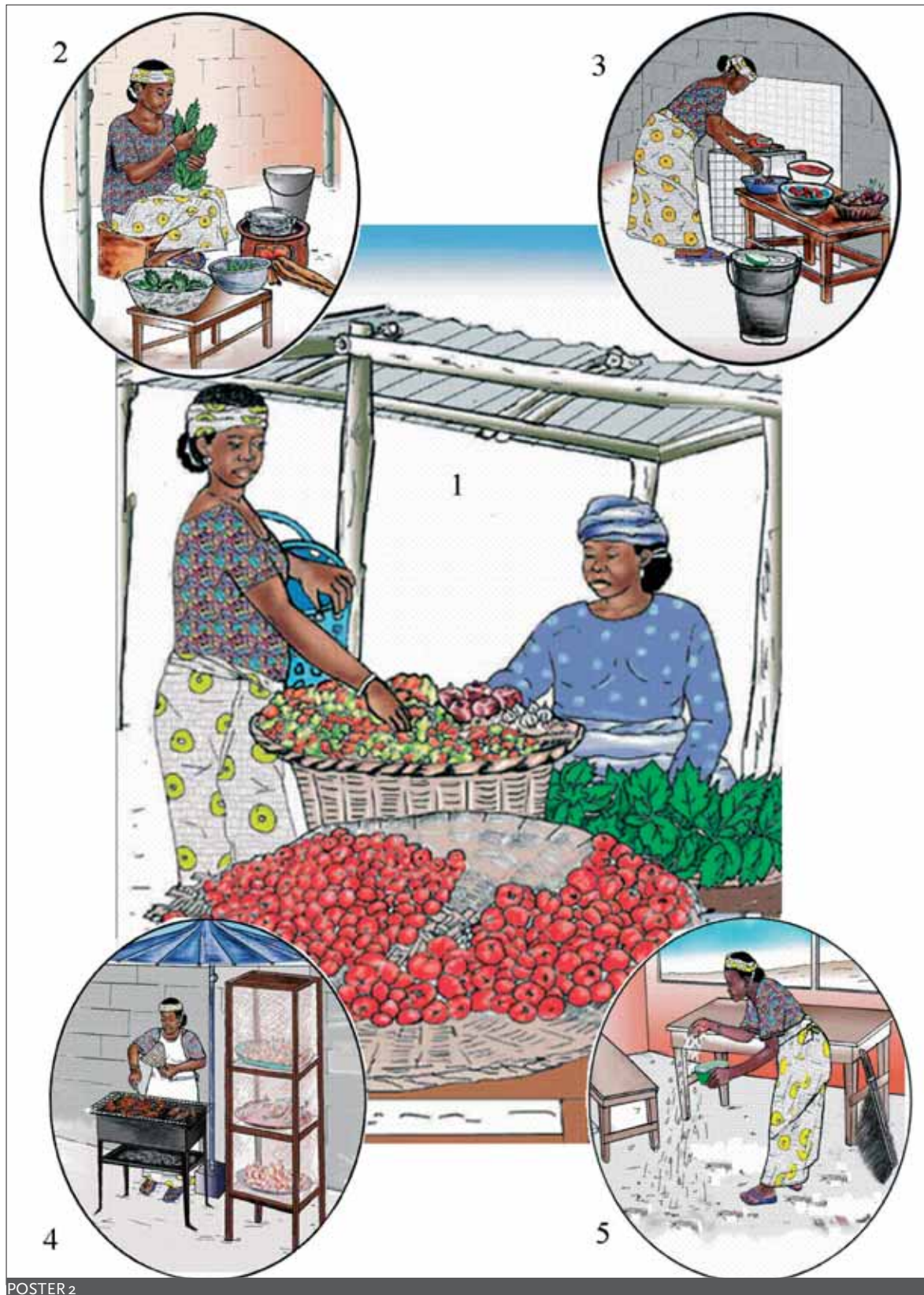

POSTER 2

**HYGIENE OF FOOD PREPARATION AND SALE POINTS:
CLEAN SANITARY PRODUCTION**

I keep my food preparation and sale area clean to avoid contamination of ingredients, raw materials and food
(practice to be encouraged)

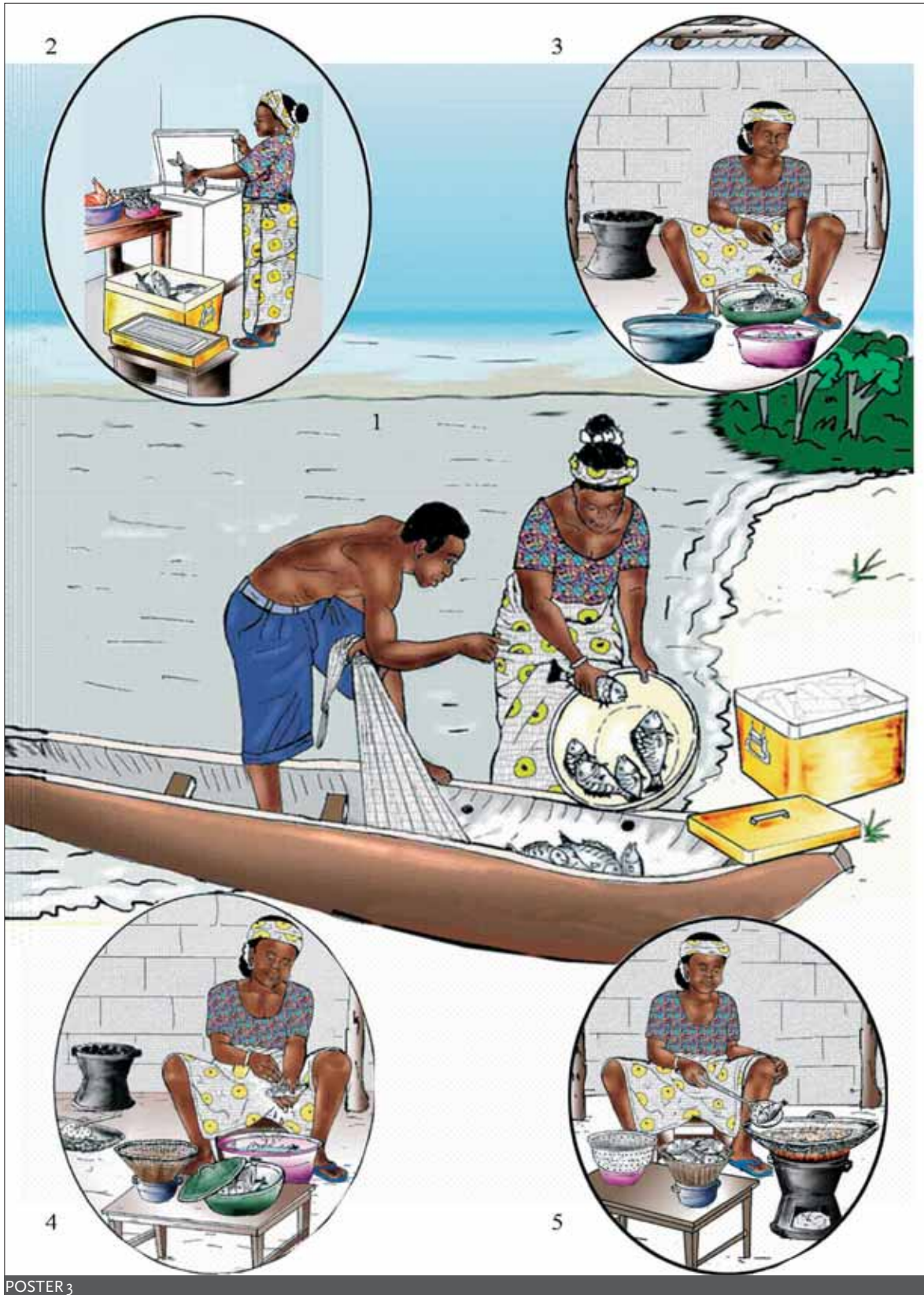

POSTER 3

PROCURING FRESH FISH, COLD STORAGE AND CAREFUL PREPARATION BEFORE COOKING

To conserve the quality of fishery products and meat, maintain the cold chain from purchase to use and carefully prepare before cooking
(practice to be encouraged)

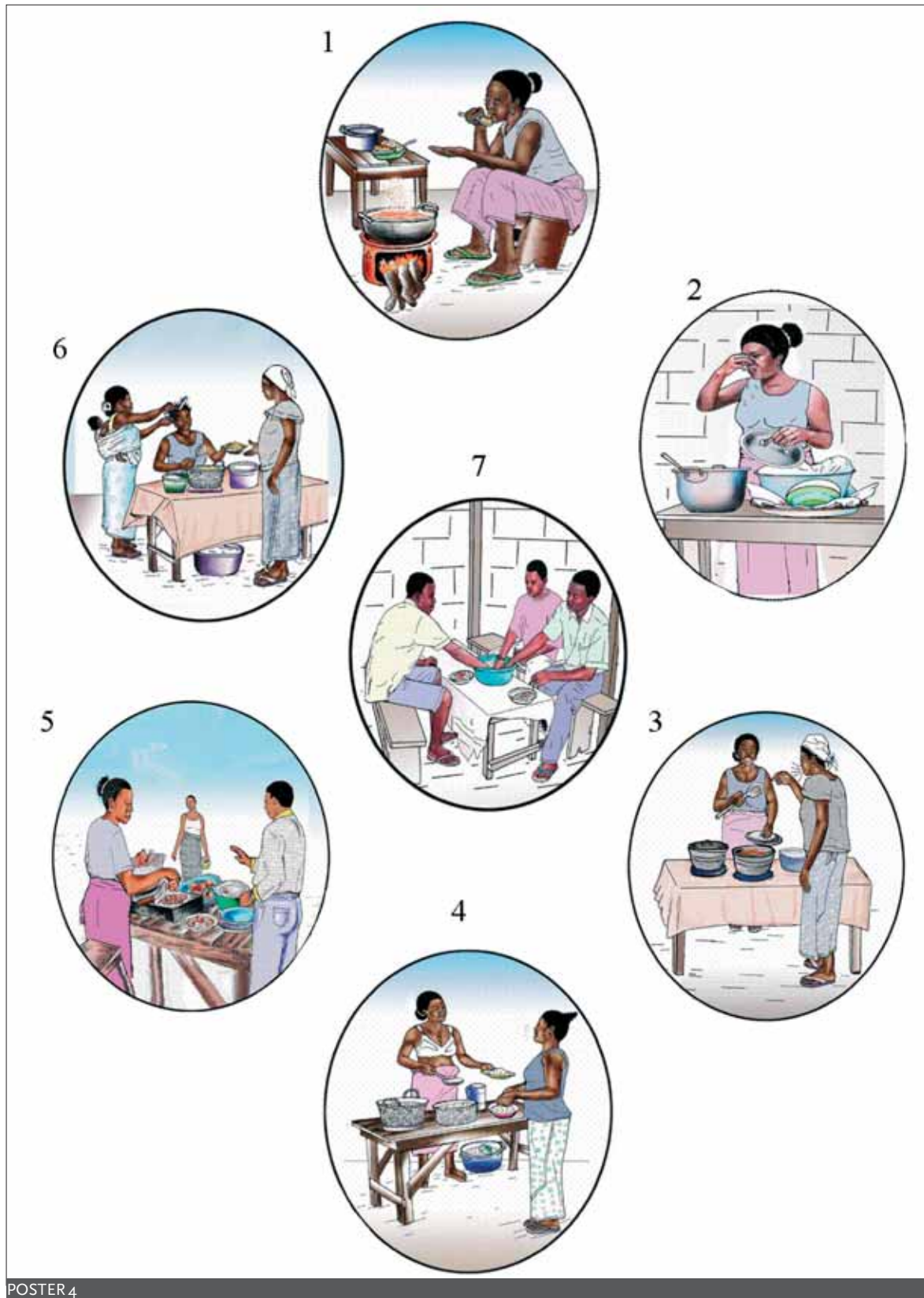

POSTER 4

UNSANITARY PRACTICES AND HABITS

To limit microbial contamination, I avoid unhealthy practices and habits at the point of food preparation and sale (**practice to be encouraged**).

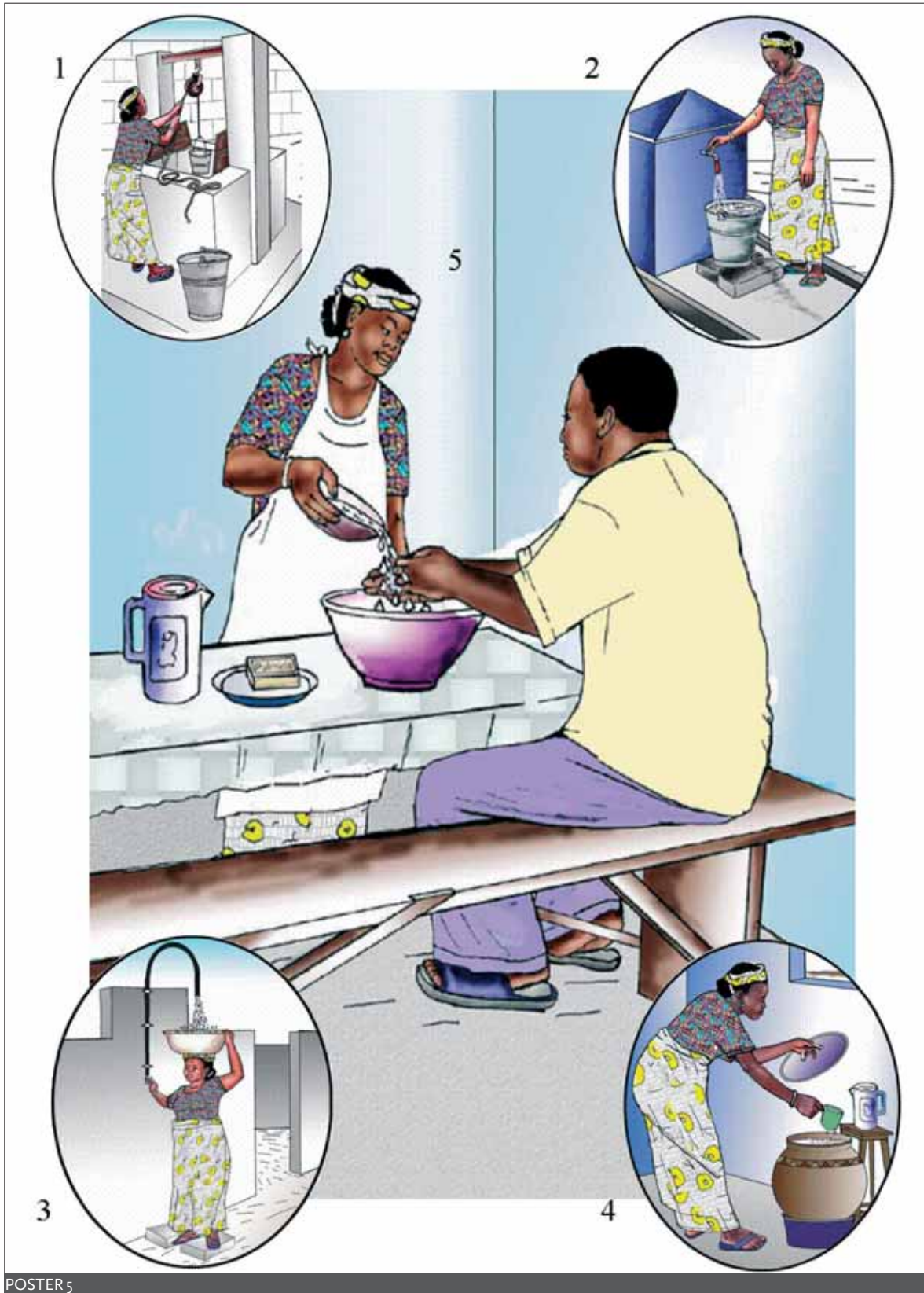

POSTER 5

GOOD MANAGEMENT OF DRINKING WATER

I collect the water I need on my food preparation and sale premises from safe sources and manage it with care.
(practice to be encouraged)

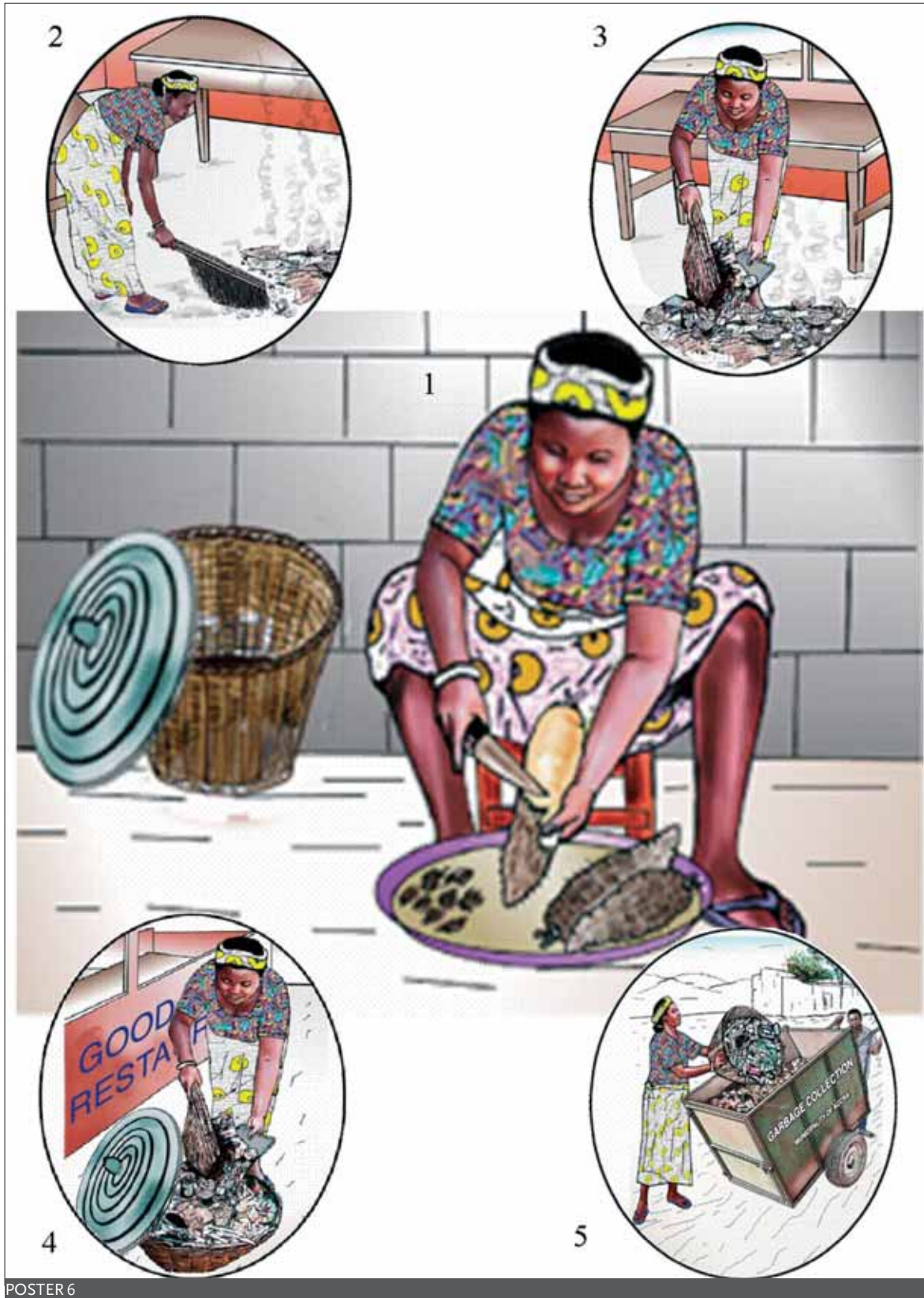

POSTER 6

GOOD WASTE MANAGEMENT

When preparing food, be sure to put your rubbish in a covered dustbin which you empty it at the end of the day into the municipal refuse container (**practice to be encouraged**).



POSTER 7

WASHING, CLEANING AND ORDERING DISHES

To avoid microbial contamination, I always wash up in sanitary surroundings and carefully order the washed dishes and utensils.
(practice to be encouraged)



Section II

SECTION II

PLAN

1.	NOTES TO TRAINERS	120
	1.1 Pedagogical approach	120
	1.2 Glossary: definition of key words	124
	1.3 Answers to exercises	127
2.	ILLUSTRATIONS AND POSTERS	132
	2.1 Presentation of illustrations and posters	132
	2.2 Adaptation of illustrations and posters to local contexts	139

1. NOTES TO TRAINERS

1.1. PEDAGOGICAL APPROACH

A. INTRODUCTION: CONDITIONS FOR SUCCESSFUL TRAINING

Your role in training street food players to adopt good hygienic practices is crucial. You will need to convey to them the vital notions needed to initiate a process of behavioural change.

Behavioural change is a long-term process. It is not immediate, nor constant. It is gradual and comes from a long period of learning.

To help street food handlers change their behaviour, you will need to dialogue with them and build an interpersonal relationship of trust and credibility. That is the purpose of these "Notes to Trainers".

A.1. BASIC NOTIONS IN COMMUNICATION

For the trainer, communication is a way of transmitting to an individual, or group of individuals, knowledge or know-how that will serve to convert harmful social behaviour into favourable social behaviour, such as the application of recommended hygiene practices. The trainer will communicate successfully if he listens to his street food interlocutors and discusses with them how best to resolve the problems they encounter.

A.2. INTERPERSONAL COMMUNICATION

Communication is between two or several persons. It serves to relay a message which is information that the trainer (the transmitter) sends to the listener (the receiver). The response or reaction of the receiver is the feedback. Thus, the main elements of interpersonal communication are transmitter and receiver. The transmitter is the person who initiates the communication. He has ideas, experience and knowledge that he wishes to share with his listeners.

The role of the communicator in any form of training is:

- to present his ideas in a language that is clear to his interlocutor. He will therefore need to know the language or dialect, the cultural context, the intellectual level and the concerns of his interlocutor;
- to choose the most suitable and straightforward way of reaching his interlocutor;
- to check that his interlocutor has understood the message, and will act accordingly. The trainer must explain the role the training participants are expected to play in the exercise of their profession.

The participants should be capable of assimilating the message. Their role is to receive and retain the message, then to act by implementing the imparted recommendations. For them to play this role, the message must be convincing and the trainer must inspire confidence. The message must provide realistic solutions to street food problems. An effective message needs to reach the mind and spirit of the individual and to create a bond between trainer and audience so that they can collectively resolve problems that may arise.

The message needs to be true, articulate and relevant. Its substance needs to be objective and logical. The operator (vendor/handler) needs to feel involved and committed. When the vendor/handler realizes the importance of the message and its implications for his life and that of the community, he will decide to act, to change his habits and to find solutions. In this case, the trainer's goal is to communicate better in order to secure an early change in food hygiene behaviour.

There are several means of transmitting a message: word-of-mouth, television, radio, role play, songs and printed materials. It is a good idea to use several means of communication (visual, auditory, sensorial...) to activate different memories (visual, auditory...) of the interlocutor and thus increase the impact of the message.

Another criterion for successful training is the trainer's willingness to receive information from his audience: 'feedback'. This can be verbal or non-verbal. It enables the trainer to gauge the impact or outcome of his work and to introduce necessary adjustments.

A.3. ELEMENTS DISRUPTIVE TO COMMUNICATION

Impediments to the successful conveyance of information exist at all levels of the communication process.

Such disruption to good communication is known as "noise" and varies in source and form. It can stem from the trainer's attitude and behaviour as much as from the training environment.

Examples:

- noise from the communication equipment: a poorly placed or malfunctioning microphone prevents the listeners from catching the message;
- noise from the training environment: engine noise from passing vehicles can disrupt oral communication and a training session;
- noise from the trainer: a trainer who arrives late, scowls and fails to apologize is disagreeable. He puts his audience off and gives the impression he does not respect them, which does little to facilitate communication;
- noise from method of work: endless discussion on a single picture can disrupt training. Ideas become confused and the message is lost;
- noise from the audience: the trainees are uncomfortable, hungry or thirsty and centre more on their discomfort than the message. Breaks are needed to restore concentration;
- noise from language register: if a trainer talks above the heads of his audience or, on the contrary, uses overly simple language for well-educated listeners, he will soon "lose" his audience.

Thus, if street food training is to be successful, a good pedagogical approach with the different players is needed concerning the rules of communication.

B. PEDAGOGICAL ORGANIZATION OF TRAINING

Training for street food operators should be organized in modules. These will be selected according to training needs and target audience.

B.1. OBJECTIVE

For each module, the trainer will need to present the overall purpose of the training and the particular objective of that module. The participants need to be informed of the training method that will be employed. Having trainees who clearly understand the content and purpose of training greatly facilitates the assimilation of notions taught. The introduction to each module should tell each trainee why it will be worth his while to concentrate during the session. He needs to perceive the prospective returns from his effort. When training is over, the audience should understand the contents and master the recommended practices.

B.2. ADVISED TRAINING METHOD

The following elements can facilitate the transfer of information:

- open discussion;
- relaxed atmosphere;
- voice of facilitator reaching the whole audience;
- interactive approach;
- extensive involvement of participants;
- identification before training of existing audience understanding of the subject to pitch the training at the correct level;
- structuring of training and gradual progression according to course sheet or notes;
- illustration with concrete examples and real experiences to bring course contents to life;
- practical exercises to assess level of assimilation.

B.3. TRAINING AIDS

A variety of aids can be used to foster the assimilation of concepts and information:

- transparencies;
- slides;
- power point projections;
- illustrations;
- posters;
- flash cards;
- mimeographs.

B.4. DURATION

The duration of a training session will depend on the audience profile. Long sessions risk audience boredom.

B.5. EXERCISES

Each module is followed by an exercise with questions to assess the level of assimilation. Each exercise should be corrected together with the participants.

The trainer is encouraged to supplement the manual with other exercises, according to training situation and level.

B.6. TRAPS TO BE AVOIDED

The following traps to good communication should be avoided:

- talking with a single person; it is much better to involve the whole group (by saying for example: “does anyone else wish to add something?”);
- paying too much attention to an incorrect answer.

B.7. STRUCTURING THE COURSE

Good presentation requires a clear course plan with the following elements:

Introduction

- explain the purpose of training and the objectives of each module;
- explain the link between the current module, the previous modules and the next modules;
- lay out the major ideas to be developed.

Content

- develop the subject stage-by-stage from your course notes: this requires a chronological and logical sequencing of from the training manual;
- concentrate more on a few in-depth, well developed and clear stages than on a multitude of stages. This point applies to the **REMEMBER** and **GOLDEN RULES** sections which present the recommendations or important aspects of each module. They summarize the core elements of the module to be remembered;
- the core elements are then supplemented by **LEARN MORE** boxes which explain some of the key points in greater depth to the trainer;
- illustrations and posters serve to portray concrete situations that will spark discussion or illustrate a message. They show correct and incorrect behaviour;
- appropriate use of visual aids and questions is recommended to elicit participant interest and attention;
- a closing summary should be given after each section.

Conclusion

- summarize the content of the training session;
- recap and link (where possible) with previous modules;
- refer trainees to other related documents they can consult.

1.2. GLOSSARY: DEFINITION OF KEY WORDS

- Bacterium
See microorganism.
- Cell
The smallest element of living beings that can exist independently. Human beings are made up of several billion cells.
- Cleaning
Elimination of dirt, food residues, fat and all other undesirable matter.
- Contaminant
Any biological or chemical agent (all foreign matter) that is not added intentionally to food products and that may jeopardize the safety or sanitary quality of those products.
- Contamination
Introduction or presence of a contaminant (foreign body that can jeopardize safety or sanitary quality) in a food environment.
- Control
Situation in which correct methods are applied and criteria satisfied.
- Corrective measure
Any measure taken when the findings of monitoring of points indicate a loss of control.
- Dirt
Anything that taints, sullies, constitutes a reservoir of pathogenic microbes, a source of contamination.
- Dishes
Glasses, plates, cups, saucers, spoons, forks, ladles, chopsticks and other implements, including disposable objects, used for serving and eating food.
- Disinfection
Reduction through chemical agent (and/or method) of microorganisms in an environment to a level not compromising food safety.
- Drinking water
Water conforming to WHO standards. Defined by the WHO as water that does not contain a pathogenic or chemical agent in concentrations that can be harmful to health.
- Equipment
Utensil, appliance, implement or object, whether traditional, artisanal or modern, used or intended for use in preparing, conserving, selling or delivering food products.
- Fauna
Assembly of animal species living in a delimited geographical area.
- Flora
Assembly of plant species living in a given environment.
- Food handler
A person preparing or selling food.
- Food hygiene
Aggregation of conditions and measures needed to ensure the safety and sanitary quality of products at all stages of the food chain and therefore the protection of the health of the consumers of those products.

- Food poisoning
Disorder resulting from the ingestion of a bacterial toxin through the consumption of contaminated food.
- Food safety
Assurance that food is without danger to the consumer when prepared and/or consumed in accordance with its intended use.
- Food sanitary quality
Assurance that food is fit for human consumption in accordance with its intended use.
- Food
Substance taken through the mouth that maintains life and growth, gives energy and builds and replaces tissues.
- Food-borne infection
Disease caused by living pathogenic microorganisms ingested through contaminated food.
- Germ
See microorganism.
- HACCP
Hazard Analysis and Critical Control Point system.
- Hazard
Physical, biological or chemical agent, or state of the food, that can have a potentially harmful effect on consumer health.
- Hazard control
All necessary measures to ensure and maintain compliance with the criteria defined in the HACCP plan.
- Microbe
Previous term for “microorganism” .
- Micrometer
Unit of measure of length equal to one thousandth of a millimetre.
- Microorganisms
Microscopic living entities found everywhere, in water, air and earth. Their size, shape and form of life determines on whether they are bacteria, yeasts, moulds, viruses or protozoa. In general terms, those with a greater impact on food safety are bacteria and moulds.
- Microscope
Optical instrument used to examine microorganisms.
- Morbidity
Relationship between number of sick and size of population.
- Mortality
Relationship between number of deaths in a population and average size of that population in a given period.
- Official stamp
Any mark or seal, or label bearing that mark or seal, certified by the competent authority.
- Pathogenic microorganisms
Microorganisms that cause disease and often infection.
- Perishable food
Any food which, because of its nature or state, is liable to spoil.

- Pest
Animal which causes major damage to a plant or food product, usually to feed itself. Example: rat, mouse, locust, caterpillar and weevil.
- Pesticide
Substance used against animal and plant parasites.
- Pesticide residue
All specific substance present in food, agricultural produce or animal feed resulting from the use of a pesticide (or a pesticide derivative).
- Pollutant
Product or agent responsible for the degradation of the human environment.
- Proliferation
Rapid multiplication, significant increase in number of bacteria through division.
- Refuse
Household waste, rubbish of all kinds.
- Regulation
Body of legal provisions regulating (here) the street food sector.
- Spoilage
Action of modifying for the worse the nature or state of something.
- Street food
Food ready to eat, prepared and/or sold by vendors/handlers operating in the street or in other public places.
- Toxic infection
Massive absorption of bacteria and toxic substances produced by those bacteria which have multiplied (here) in the food.
- Toxin
Poison, toxic substance produced by a living organism (bacterium, poisonous mushroom) to which it confers its pathogenic capacity.
- Utensils
Objects used for every day purposes, especially cooking.
- Wastewater
Dirty water resulting from the activity of food vendors/handlers.
- Water hazard
Body of diseases and conditions transmitted to humans through contact with water meant for a variety of uses (preparation of food and beverages, personal hygiene, etc.) containing potential sources of bacteria (faecal matter, pests and domestic animals).
- Waterproof
Retains and does not allow the passage of fluids in general.

1.3. ANSWERS TO EXERCISES

MODULE 1. CONTAMINATION OF STREET FOOD

Exercise 1

1. What are the agents responsible for food contamination?
2. What are the possible origins of microbes that contaminate street food?
3. What are the consequences for the consumer of street food contaminated with microbes?

Answers to questions

1. Microbes are part of the agents responsible for food contamination. They can be classified into five (5) main groups: bacteria, yeasts, moulds, viruses and protozoa. But there are other agents of food contamination, in particular physical and chemical agents, including:
 - heavy metals (copper, lead, etc.);
 - pesticide and fertilizer residues;
 - residues of chemical substances used in veterinary products and chemical additives such as colouring, flavouring and preservation agents not authorized for food preparation.
2. The presence of microbes in street food may be due to:
 - inadequate protection of the food;
 - insufficient and ineffective conditions of cooking when the raw materials themselves are unclean;
 - use of untreated human or animal fertilizer. The situation is compounded when the produce is not properly washed in clean water;
 - drinking water and ice sold in markets and streets that are often contaminated by different types of pathogenic germ.
3. There are many conditions to which consumers are exposed by consuming contaminated food. These food-borne microbial diseases can affect one or several people at the same time. They include:
 - infections caused by bacteria in the food which can lead to disease such as typhoid fever;
 - poisoning from toxins secreted by bacteria such as *Clostridium botulinum*, which causes botulism, a condition that is often fatal;
 - toxic infections associated with ingestion of insufficiently cooked beef or pork infected with tapeworm, for example. These infections can also result from the ingestion of vegetables contaminated by wastewater or faecal matter containing amoeba or roundworm eggs;
 - sickness from natural poisoning in mushrooms which can be fatal without immediate attention.

For further information, refer to **Table 1: Principal microbial diseases related to food consumption.**

MODULE 2. HYGIENE AND QUALITY OF RAW MATERIALS AND INGREDIENTS

Exercise 2

1. What are the key criteria or principles when selecting raw materials and ingredients? Give specific examples.
2. How can raw materials be stored for keeping on return from the market? Explain with specific examples.

Answers to questions

1. The following rules should be observed when purchasing raw materials:
 - visually check their freshness, appearance, variety and quality as well as the hygiene of the vendor and his surroundings.
 - check the best-before and use-by dates.
 - refuse any produce with defects.
 - check the quality of the produce (smell, presence of foreign bodies, insects, etc.).
 - only purchase raw materials and ingredients from vendors who observe the basic rules of hygiene for their person, dress and behaviour.

For more information refer to the different cases covered in this module (meat, eggs, canned food).

2. On return from the market, food products should be carefully wrapped against weather, insects and any form of contact that could cause contamination.
 - for bulk food and especially grains, waterproof containers are better than bags and should be placed on clean tables or shelves as protection against pests such as mice;
 - avoid placing condiments, vegetables, fruits and other foodstuffs on the ground where they are exposed to flies, dust and domestic animals. Keep them in clean containers placed on tables or shelves. Meat and fish should be put into a freezer when not immediately used;
 - protect foodstuffs with lids or plastic sheeting;
 - systematically discard raw materials that are spoilt or rotting (e.g. tomato, sweet pepper, fruit, etc.) so as not to contaminate others;
 - control insects and pests with traps rather than poison, especially rat poison which is also dangerous for humans;
 - see that premises, storage area, shelving and packages are kept clean;
 - check the cleanliness of personnel in direct contact with or access to storage or holding areas.

MODULE 3. HYGIENE OF FOOD PREPARATION AND VENDING PREMISES AND EQUIPMENT

Exercise 3

1. How can we organize the monitoring and detection of pests?
2. How can we eliminate pests without creating a risk of food poisoning?

Answers to questions

1. The monitoring and detection of pests requires rigorous control, so it is important to prevent them from entering and establishing themselves in food preparation and sale areas.

How to prevent pests entering food preparation and sale areas?

- Food preparation and sale areas should be kept constantly clean to sanitize potential pest breeding grounds (weevils).
- Holes and channels providing pests with access to food stores should be protected or blocked. Domestic animals should be barred from food preparation and sale establishments as far as possible.

How to avoid pests establishing themselves in food preparation and sale areas?

- The presence of food and water attracts pests. Foods likely to attract pests should be kept in

sealed containers above ground level and away from walls. Areas inside and outside food stores should be kept clean.

- Rubbish should be placed in covered containers that are inaccessible to pests. These should be as far as possible from the food preparation and sale area;
 - There should be regular checks for the presence of pests on premises and in neighbouring areas;
 - Pest infestation should be immediately dealt with without compromising food safety or sanitary quality. Chemical, physical or biological treatment should be applied taking care to avoid the risk of consumer food poisoning.
2. Good sanitary measures, inspection of raw materials and careful observation can minimize the risks of infection and therefore limit recourse to pesticides (insecticides, rat poison). As appropriate, use biological treatment or chemical and physical treatment of the food preparation and sale areas and the storage areas for raw materials and ingredients (traps, cleanliness, premises not conducive to pest infestation, monitoring doses of chemical product applied and, if necessary, calling in qualified technicians).

MODULE 4. PERSONAL HYGIENE AND HYGIENIC METHODS AND PRACTICES IN THE STREET FOOD SECTOR

Exercise 4

1. What are the rules of hygiene that ensure the proper management of household waste?
2. When should you wash your hands when selling street food?
3. How should you wash your hands when preparing and selling street food?
4. What are the five rules of cleaning for street food hygiene?

Answers to questions

1. The rules of hygiene for the proper management of household waste are the following:
 - do not throw household waste on the ground to avoid attracting insects, pests and domestic animals (dogs and cats);
 - discard solid and liquid waste separately;
 - clean household dustbins every day;
 - prevent animals from licking the plates.
2. Food safety assurance requires the washing of hands which should become a reflex action. Hands should therefore be washed:
 - at the beginning of the working day;
 - after handling raw products;
 - before touching cooked food;
 - before resuming work (after a break, telephone call, cigarette, meal, etc.);
 - after going to the toilet;
 - after touching your hair, mouth, nose, etc.;
 - after touching dirty objects (dustbins, etc.) or handling potentially contaminating food (vegetables, eggs, raw meat, packages, etc.);
 - after sneezing, coughing or blowing your nose;
 - after contact with toxic substances such as pesticides and disinfectants.

3. To wash their hands, street food vendors/handlers must:
 - run their hands through warm water;
 - take some soap and work up a froth by rubbing their hands and forearms repeatedly;
 - thoroughly rinse their hands with clean water;
 - dry their hands with a single-use hand towel;
4. Clean – Wash – Rinse – Disinfect – Wash.

MODULE 5. HYGIENE AND QUALITY OF RAW MATERIALS AND INGREDIENTS

Exercise 5

Microbes are all around us and can spread disease through various channels:

1. Name some of those channels.
2. How can we limit the spread of microbes?

Answers to questions

1. Water, animals and insects, air, food, interpersonal contact.
2. By washing our hands with clean water and soap:
 - after going to the toilet;
 - after touching animals;
 - before and after eating;
 - before and after handling food;
 - by washing all cuts and grazes on our body with boiled water and soap, and covering them with a clean bandage.

MODULE 6. REGULATION AND CONTROL OF STREET FOOD QUALITY

Exercise 6

1. What actions and measures need to be taken before operating in the street food sector?
2. What are the main factors of risk that facilitate contamination?
3. What are the critical control points in the HACCP system applied to street food? Illustrate with a precise food example.

Answers to questions

1. The preparation and sale of street food require prior authorization from the competent authority. Street food vendors/handlers need to have a prior medical examination and to have undergone tests including stool, urine and saliva and IDR (Intra Dermo Reaction). The need to be free of disease and to pay a daily charge.
2. Risk factors facilitating street food contamination exist at different levels:
 - unclean water;
 - contaminated or poorly washed raw materials;

- unclean work materials;
 - preparation and sale of food in unsanitary surroundings;
 - uncovered food;
 - poor storage and keeping conditions;
 - use of a limited number of pots or plates;
 - poor hygiene and health of street food operators;
 - various other unhygienic habits and practices of operators and consumers (poor personal hygiene, inappropriate clothing, improper conduct during preparation, keeping, sale and consumption of food).
3. The stages of control under the principles of the HACCP system applied to street food are:
- source and quality of water used;
 - selection, storage and keeping of raw materials used in food preparation to verify their safety;
 - hygiene of food preparation, keeping, transport and distribution equipment;
 - the food preparation, sale, storage and keeping operations, in particular:
 - the preparation and sale surroundings;
 - the protection of food to be sold;
 - the storage and keeping of food ready for sale.
 - the state of premises, the organization and management of work place and the preventive hygiene measures implemented;
 - the health of food handlers, their personal hygiene, the cleanliness of their clothing and their practices during food preparation and sale.

Refer by way of example to Module 6 – Section II: Flow diagram of hazards and preventive measures: precooked food.

2. ILLUSTRATIONS AND POSTERS

Illustrations and posters are visual aids that help the audience better understand and assimilate information through powerful images accompanied by messages conveying food hygiene rules. Such illustrations and posters portray practices to be encouraged and others to be discouraged.

2.1. PRESENTATION OF ILLUSTRATIONS AND POSTERS

MODULE 1: CONTAMINATION OF STREET FOOD

Illustration 1.1

Description: A laboratory technician examining a microscope sample of food contaminated by microbes.

Message: Let's avoid contact between food and dirty environment (water, air, ground) to prevent contamination by microbes invisible to the naked eye.

Illustration 1.2

Description: A woman selling food in an area polluted by vehicle exhaust fumes (**practice to be discouraged**).

Message: Let's avoid exposing our food to vehicle exhaust fumes and reduce the risk of chemical contamination and harm to consumers.

MODULE 2: HYGIENE AND QUALITY OF RAW MATERIALS AND INGREDIENTS

Illustration 2.1

Description: Purchasing meat from a clean stall: a woman buying meat from a traditional butcher. We can see:

the cleanliness of the surroundings:

- there is no rubbish or household waste;
- the merchandise is displayed with professional competence;
- the butcher is clean in appearance;
- he is holding a fly-whisk.

evidence of veterinary inspection:

- a visible stamp on the carcass (**practice to be encouraged**).

Message: I buy my meat from a clean butcher's stall with evidence of veterinary inspection.

Illustration 2.2

Description: A woman buying her tomato, chilli and onion supplies from a vendor of fresh produce displayed in raised baskets in clean surroundings (practice to be encouraged).

Message: I buy my vegetables and spices from a vendor who can guarantee their freshness and sanitary quality.

Illustration 2.3

Description: A woman buying vegetables and spices displayed on the ground in unsanitary surroundings (**practice to be discouraged**).

Message: Avoid buying raw materials displayed in unsanitary surroundings.

Illustration 2.4

Description: A woman buying recently landed fish. She buys her fishery products from suppliers who can guarantee their freshness and transports her purchases in an ice-cooler (**practice to be encouraged**).

Message: I buy my fish and fishery products from suppliers who can guarantee their freshness.

Illustration 2.5

Description: A woman selling fish covered with flies; the street food operator gives her a miss and goes to another vendor whose fish, practices and conditions seem more hygienic (**practice to be encouraged**).

Message: Avoid buying fish and fishery products that are not covered and are poorly kept.

Illustration 2.6

Description: Purchasing meat from a hygienic stall (urban setting) like this modern butcher's (**practice to be encouraged**).

Message: In town, I buy meat from a modern butcher's.

Illustration 2.7

Description: On her return from market, a woman carries all her supplies (animal and vegetable products) in the same basket (**practice to be discouraged**).

Message: Do not put all your purchases of raw materials and ingredients in the same basket.

Illustration 2.8

Description: On her return from market, a woman carries her purchases in different baskets, some of them covered (**practice to be encouraged**).

Message: I cover my purchases of raw materials and ingredients against dust and dirt and avoid mixing them.

Illustration 2.9

Description: A woman transferring her purchases from ice-cooler to freezer to avoid breaking the cold chain between purchase, storage and preparation of fish (**practice to be encouraged**).

Message: Avoid breaking the cold chain between purchase, storage and preparation of meat and fish.

MODULE 3: HYGIENE OF FOOD PREPARATION AND VENDING PREMISES AND EQUIPMENT

Illustration 3.1

Description: A woman draining her dishes in a raised plastic basket (**practice to be encouraged**).

Message: After washing and rinsing in clean water without detergent, I dry my dishes in a raised plastic basket.

Illustration 3.2

Description: In clean surroundings, a woman washes her dishes in a basin of soapy water. She has two other basins with clean water for rinsing. There is also a dish with a bar of soap (**practice to be encouraged**).

Message: I always avoid washing up in unclean surroundings to reduce microbial contamination. After washing, I rinse dishes in two basins of clean water.

Illustration 3.3

Description: A woman carefully ordering her cooking utensils to make best possible use of space; the cutting boards and saucepans are hung from nails in the wall; the dishes are stacked in plastic mesh baskets (**practice to be encouraged**).

Message: Carefully order your cooking utensils and lids to have more space in your kitchen.

Illustration 3.4

Description: A woman washing up on the ground in unhygienic conditions (**practice to be discouraged**).

Message: I avoid washing up in unhygienic surroundings to reduce microbial contamination.

MODULE 4: PERSONAL HYGIENE AND HYGIENIC METHODS AND PRACTICES IN THE STREET FOOD SECTOR

Illustration 4.1

Description: A woman having her hair done while serving food (**practice to be discouraged**).

Message: For my personal hygiene and the safety of the food I sell, I make sure I am clean and avoid doing my hair where the food is prepared and sold.

Illustration 4.2

Description: A woman wearing clean clothing, an apron and headscarf. Her assistant is also very clean (**practice to be encouraged**).

Message: Where food is prepared and sold, a vendor should always be clean and properly dressed to avoid contamination.

Illustration 4.3

Description: A woman serving food while improperly dressed (**practice to be discouraged**).

Message: I should not be dirty or improperly dressed to avoid contaminating the food I am selling.

Illustration 4.4

Description: A woman directly tasting sauce (or other food) from the cooking spoon (**practice to be discouraged**).

Message: To avoid contaminating the food you are preparing, do not taste it directly from the cooking or serving spoon.

Illustration 4.5

Description: A woman tasting food placed in the palm of her hand (**practice to be encouraged**).

Message: Taste sauces (and other food) from the palm of your clean hand.

Illustration 4.6

Description: A woman using her bare hand to serve customers (**practice to be discouraged**). The customer objects (**practice to be encouraged**).

Message: I avoid serving customers with my bare hand.

Illustration 4.7

Description: A woman serving a customer with a fork (**practice to be encouraged**).

Message: To avoid contamination from my bare hand, I serve customers with an implement (spoon, fork, ladle...).

Illustration 4.8

Description: A woman talking and sputtering over the food she is serving (**practice to be discouraged**).

Message: I avoid talking over the food I am serving.

Illustration 4.9

Description: A woman blowing her nose over her food (**practice to be discouraged**).

Message: For food safety and hygienic premises, I avoid blowing my nose over the food.

Illustration 4.10

Description: A woman sorts, washes and blanches leafy vegetables before use (**practice to be encouraged**).

Message: Before using food items, make sure they are properly cleaned and prepared.

Illustration 4.11

Description: A woman uses two bowls of water to clean and rinse condiments to make sure they are clean and hygienic before grating and use (**practice to be encouraged**).

Message: Carefully wash food and condiments before preparation and use.

Illustration 4.12

Description: A woman using a cart to transport covered containers of prepared food to the points of sale (**practice to be encouraged**).

Message: When transporting prepared food, make sure it is protected against dirt by covering the containers.

Illustration 4.13

Description: A woman street vendor simmering her sauce to avoid contamination and deterioration (**practice to be encouraged**).

Message: Avoid contamination, deterioration and fermentation of prepared foods by keeping them hot.

Illustration 4.14

Description: Before serving, a woman vendor helps a customer wash his hands with clean water in a bowl (**practice to be encouraged**).

Message: Wash your hands with clean water before and after meals.

Illustration 4.15

Description: A customer washing his hands under the tap of a closed water tank. The dirty water is collected in a bowl under the tap (**practice to be encouraged**).

Message: Wash your hands under clean running water before and after meals.

Illustration 4.16

Description: Several people washing their hands in the same bowl (**practice to be discouraged**).

Message: Customers should not wash their hands at the same time, or one after the other, in the same bowl of water.

MODULE 3: HANDLING WATER IN STREET FOOD PREPARATION AND VENDING

Illustration 5.1

Description: A woman collecting water from a high-risk source of contamination (watercourse) (**practice to be discouraged**).

Message: I avoid collecting water for consumption from high-risk sources of contamination.

Illustration 5.2

Description: A woman collecting drinking water from a clean source: a standpipe connected to the grid (**practice to be encouraged**).

Message: I fetch my drinking water from safe sources such as the grid.

Illustration 5.3

Description: A woman collecting drinking water from a clean source (well with rim and cover) (**practice to be encouraged**).

Message: I collect my drinking water from safe sources such as wells with rim and cover.

Illustration 5.4

Description: A well with rim and cover (**practice to be encouraged**).

Message: Always place your wells far from latrines and keep them covered against contamination.

Illustration 5.5

Description: A woman serving drinking water from a jug (**practice to be encouraged**).

Message: I provide my customers with drinking water in an appropriate container.

Illustration 5.6

Description: Good management of drinking water at a food preparation and sale outlet means keeping it in a large covered recipient and serving it with a clean beaker (**practice to be encouraged**).

Message: I always cover my drinking water and serve it with a clean beaker.

PRESENTATION OF POSTERS

Poster 1: Hygiene of food preparation and sale points: unsanitary production.

Description: A woman adopting unhygienic practices during the preparation and sale of street food (**practice to be discouraged**).

Message: Adopt healthy recommended practices to avoid contaminating meals and ensure food safety.

Poster 2: Hygiene of food preparation and sale points: clean sanitary production.

Description: Presentation of a clean environment for food preparation and sale (**practice to be encouraged**).

Message: I always keep my food preparation and sale area clean and distant from rubbish (solid and liquid waste), stagnant water and latrines.

- Poster 3:** Procuring fresh fish, cold storage and careful preparation before cooking.
- Description:* A woman about to place her fish in an ice-cooler after purchase at the landing point. Before cooking she carefully scales, washes, rinses and drains the fish (**practice to be encouraged**).
- Message:* Before preparing fishery and meat products, maintain the cold chain between purchase and storage.
- Poster 4:** Unsanitary practices and habits.
- Description:* An unsanitary environment for the preparation and sale of street food in terms of personal hygiene, cleanliness of clothing, conduct and operational hygiene (**practice to be discouraged**).
- Message:* I avoid unsanitary practices and conduct when preparing and selling street food to avoid microbial contamination.
- Poster 5:** Good water management.
- Description:* A woman fetching water from different sources of drinking water (**practice to be encouraged**)
- A woman serving drinking water from a jug (**practice to be encouraged**)
- Message:* I fetch drinking water from safe sources guaranteed by the competent services.
- Poster 6:** Good waste management
- Description:* Proper management of solid and liquid waste from food preparation and cooking:
- A woman peeling cocoa yam. She has a basket close by for the waste (**practice to be encouraged**).
- Message 1:* During a day's food preparation, place your rubbish in a dustbin that you keep covered.
- A woman emptying her dustbin into the municipal cart at the end of the working day (**practice to be encouraged**).
- Message 2:* At the end of the working day I empty my dustbin into the municipal cart.
- Poster 7:** Washing, cleaning and storing dishes
- Description:* In a clean working area, a woman washes her dishes in a bowl of soapy water and has two other bowls with clean water for rinsing. On the side we can see a dish with bar of soap (**practice to be encouraged**).
- A woman drying her dishes in a raised basket (**practice to be encouraged**).
- Message:* To avoid microbial contamination, I always wash my dishes in a clean environment and place the dishes in a raised basket.

2.2. ADAPTING ILLUSTRATIONS AND POSTERS TO LOCAL CONTEXTS

The above illustrations and posters are only indicative and might not correspond to local reality. We recommend that trainers update and adapt them as necessary to the local context so that vendors can better identify with their content. Some practices to be encouraged or discouraged among street food handlers, vendors and consumers might need to be modified, removed or added. This will help convey the message and will enhance operator take-up of recommended hygienic practices.

Section III

ANNEXES: TECHNICAL FACT SHEETS

In order to minimize the risks of contamination of all sorts of food from dirt, a number of practical tips adapted to the African context, and in particular its market context, are proposed in the following fact sheets. These tips will enable street food vendors and handlers to maintain their utensils and ensure a clean work environment. However, visible hygiene is not enough; the professional conscience of each operator also has a key role in ensuring hygiene.

- Annex 1: use of chlorine bleach
- Annex 2: care and cleaning of utensils and appliances
- Annex 3: diagrams of prototype food vending carts
- Annex 4: cleaning and disinfecting food preparation and vending premises

Annex 1

USE OF CHLORINE BLEACH

USING A COMMON DISINFECTANT: CHLORINE BLEACH

1. Properties of chlorine bleach

Chlorine bleach is a powerful, economical disinfectant that destroys bacteria, moulds, spores and viruses.

2. Composition of chlorine bleach

It is a solution of sodium hypochlorite and sodium chloride.

3. Presentation

In flasks or tablets of strengths:

- 9 chlorometric degrees (° Chl), equivalent to 2.6% active chlorine
- 12° Chl equivalent to 3.6% active chlorine
- 35° Chl equivalent to 9.6% active chlorine

A 25 centilitre pack at 48° Chl diluted in 75 centilitres of water will produce one litre of 12° Chl bleach ready for use.

4. Utilization

Chlorine bleach should be diluted in cold or warm water.

Chlorine bleach should always be used alone without combining another household product.

5. Practical application

UTILIZATION	DOSE OF CHLORINE BLEACH AT 9° Chl Equivalent to 2.6% active chlorine	TIPS
Premises, floors, doors, work areas, tiled or plasticized surfaces	2 glasses (300 ml) for one bucket of water (10 litres)	Clean, rinse, bleach, leave 10 mins to react, rinse (with clean water for work areas)
Large appliances, dustbins, cutting boards	20 glasses (3 litres) for one bucket of water (10 litres)	Dismantle, scrape, clean, rinse, bleach, leave to react 15 mins, rinse
Dishes, kitchen utensils, tableware, sink	1 glass (150 ml) for one bucket of water (10 litres)	Clean, rinse, bleach, leave to react 15 mins, rinse with clean water
Refrigerator	5 glasses (750 ml) for one bucket of water (10 litres)	Apply the bleach solution with sponge, leave to react 10 mins, rinse with clean water
Toilets, W.C. siphons	1½ glasses (225 ml)	Pour the chlorine bleach directly, leave to react 15 mins, rinse
Sponges, cloths	2 glasses (300 ml) for one bucket of water (10 litres)	Leave to soak 5 mins, rinse
Vegetables, salads, fresh herbs	3 soup spoons (30 ml) for 50 litres of water.	Soak, wash in clear water for 15 mins, remove water and replace with bleach solution, soak the salads and vegetables, leave to react 5 mins, rinse with clean water, drain

Annex 2

CARE AND CLEANING OF UTENSILS AND APPLIANCES

SHEET N°1: ABRASIVE PASTE

1. Preparation

Abrasive paste is a mix of wood ash and soap powder or Marseille soap grated and sometimes reduced to powder.

Mix two volumes of wood ash with one volume of soap. Add a little water to obtain a paste.

The ingredients are therefore:

- 1 measure of soap + a little water
- 2 measures of wood ash

2. Utilization

Abrasive paste is used to polish cooking utensils, appliances and other equipment.

SHEET N°2: CARE OF ALUMINIUM UTENSILS

1. Materials

- Brush
- Aluminium pan to be cleaned

2. Products

- Water
- Abrasive paste (see sheet 1)

3. Instructions

- Rub the dry pan with the abrasive paste
- Pre-wash
- Wash with soapy water (Marseille soap)
- Rinse copiously
- Wipe with a clean, dry cloth
- Put the materials, products and utensils away

SHEET N°3: CARE OF STAINLESS STEEL UTENSILS

1. Materials

- Basins, bucket
- Bowls
- Brush

2. Products

- Water, grated Marseille soap

3. Instructions

- Wash in soapy warm water
- Rinse in clear water

- Wipe with dry clean cloth
- Put materials and products away

SHEET N°4: CARE OF DISHES

1. Materials

- dual-compartment sink, 3 basins
- 1 brush
- 1 easy-to-wash cloth
- 2 dish cloths

2. Products

- Warm water
- Hot water for rinsing
- Sulphonate products (products for washing-up)

3. Instructions

Wash-up as soon as possible after each meal.

3.1. Preparation

- Remove all leftovers from dishes
- Rinse plates and pans to detach the food
- Place dirty dishes on the side of the sink, first the non-fatty dishes: glasses, coffee cups, dessert plates, then the fatty dishes: saucepan lid or serving dish, stacked plates, platters, saucepans, frying pan
- Prepare the water for washing and rinsing

Warm water + Selected product

↓
Washing

Hot water

↓
Rinsing

3.2. Operation

- Wash the dishes in a bowl or basin, one item at a time, starting with the non-fatty dishes, and renewing the water as necessary
- Rinse in the other bowl or basin
- Renew the water several times as necessary
- Drain on the draining board

3.3. Ordering

- Wipe and stow the dishes as you go along
- Clean the sink or basins
- Pass the floor cloth as necessary

SHEET N°5: CARE OF REFRIGERATOR

1. Description and functioning of refrigerator

A refrigerator is a compartmentalized chilling cabinet. It supplements or replaces the cold chambers.

Refrigerators produce cold by evaporating a sealed liquid to absorb heat. It has a cabinet and compressor. The normal volume of a household refrigerator is 120 litres.

The cold storage of food does not change its nutritional value. It does not destroy enzymes or vitamins. The refrigerator is activated by a thermostat that switches the current on or off as the inside temperature exceeds or falls below a set value.

The atmosphere in a refrigerator is cold and dry because of the deposit of ice on its coils. The coils need to be de-iced when the ice acquires a certain thickness. Modern refrigerators are equipped with a mechanism that does this automatically.

You will have to use the following materials and products to maintain your refrigerator:

2. Materials

- Bucket
- Clean cloth or rag
- Floor cloth

3. Products

- Water
- Soap
- Diluted chlorine bleach (or other disinfectant)

4. Instructions

- Unplug the refrigerator and remove the shelves, ice-trays and vegetable drawers
- Clean the inside of the fridge with soapy water, rinse with clean water and disinfect with a sponge soaked in diluted chlorine bleach, then leave to dry
- Do the same for the shelves, trays and drawers
- Fill the ice-trays with water and switch the refrigerator back on.

Annex 3

DIAGRAMS OF PROTOTYPE FOOD VENDING CARTS

PROTOTYPES OF VENDING CARTS

Proposed prototypes:

- A countertop with central stove and cover
- A glass panelled cabinet for food protection
- Closed container for beverages.

These prototypes were produced under an FAO Technical Cooperation Programme (Project TCP/SEN/8822-A) entitled “Strategy for Reorganizing the Street Food Sector in Dakar”. The prototypes are designed for easy local reproduction with commonly available materials.

FOOD CART FITTED WITH COVER AND COUNTERTOP WITH CENTRAL STOVE

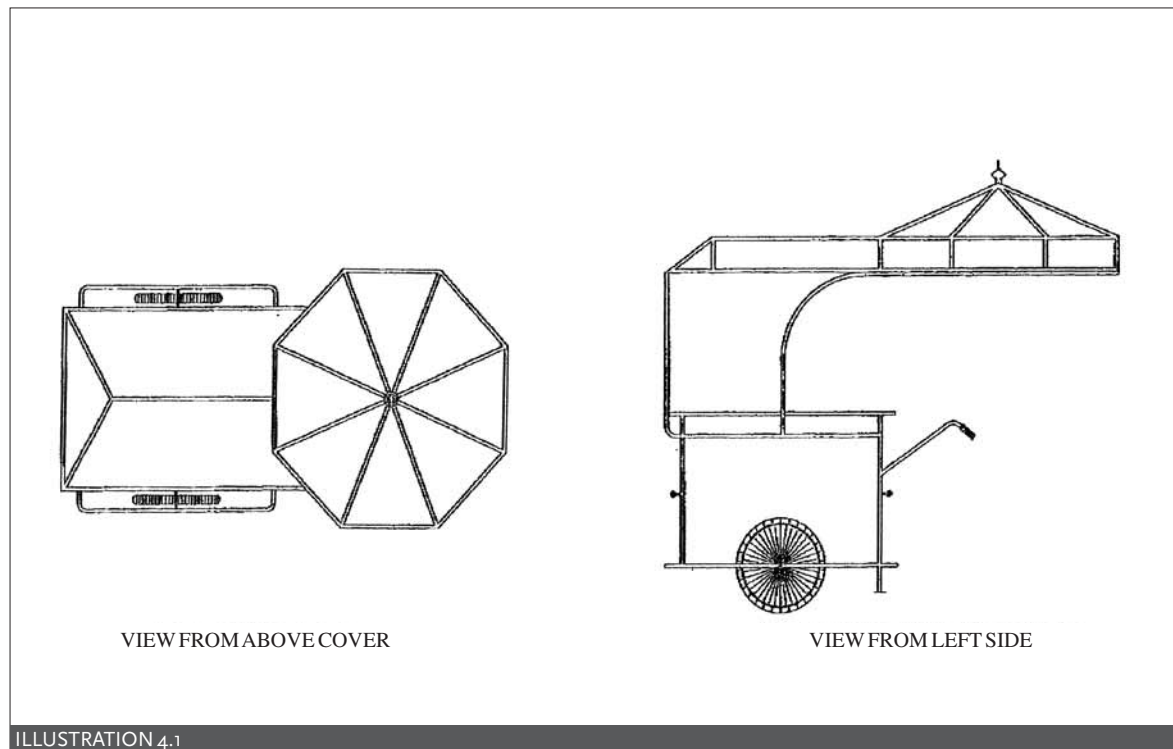

SOURCE: project TCP/SEN/8822 (A)

FOOD CART WITH COVER AND COUNTERTOP WITH CENTRAL STOVE

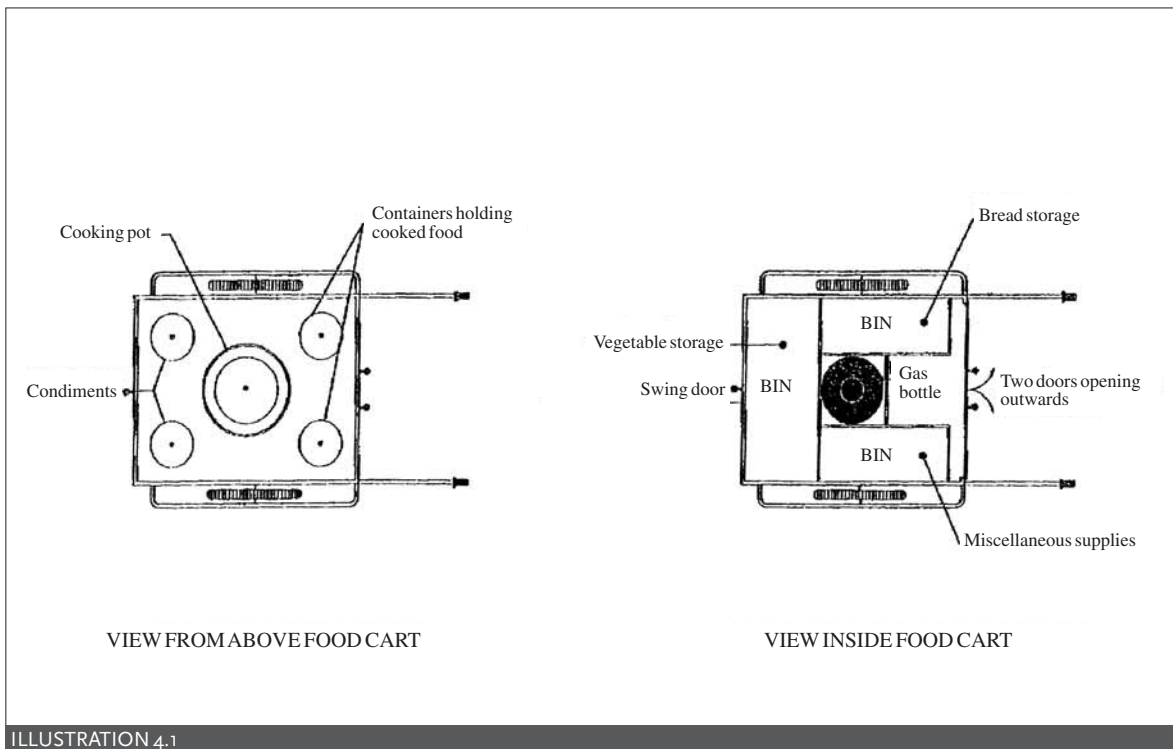

SOURCE: project TCP/SEN/8822 (A)

FOOD CART WITH COVER AND COUNTERTOP WITH CENTRAL STOVE

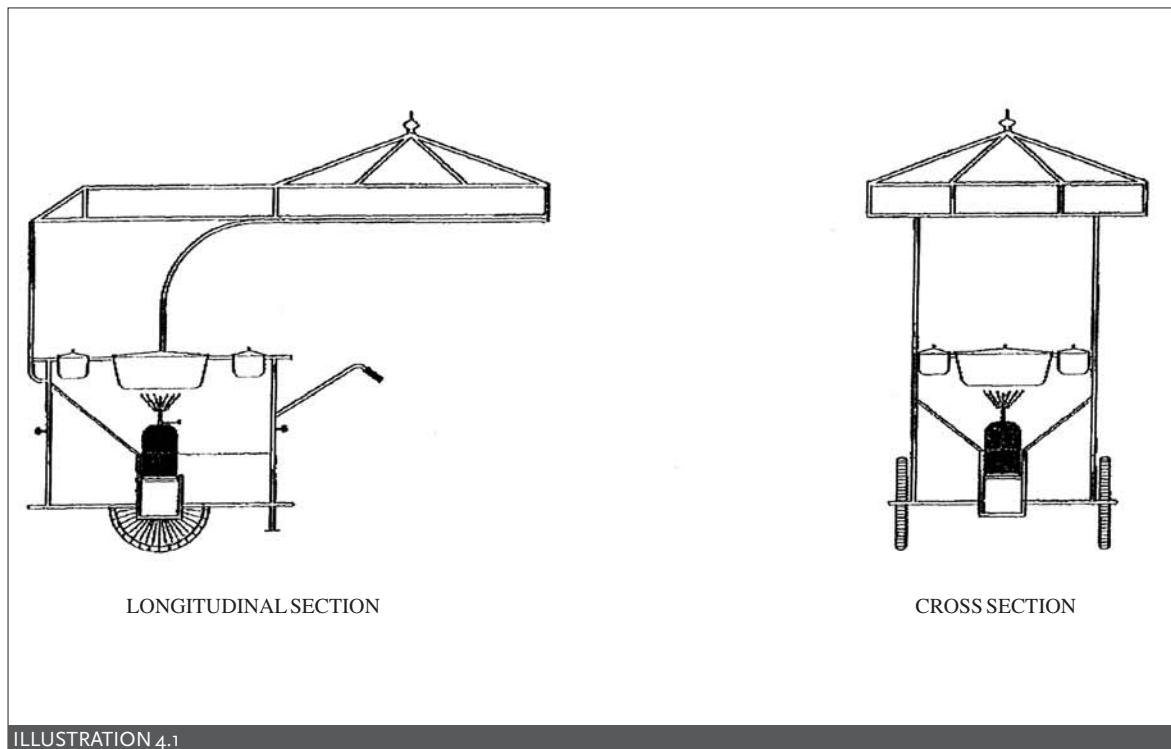

SOURCE: project TCP/SEN/8822 (A)

FOOD CART WITH COVER AND GLASS PANNELLED CABINET FOR FOOD PROTECTION

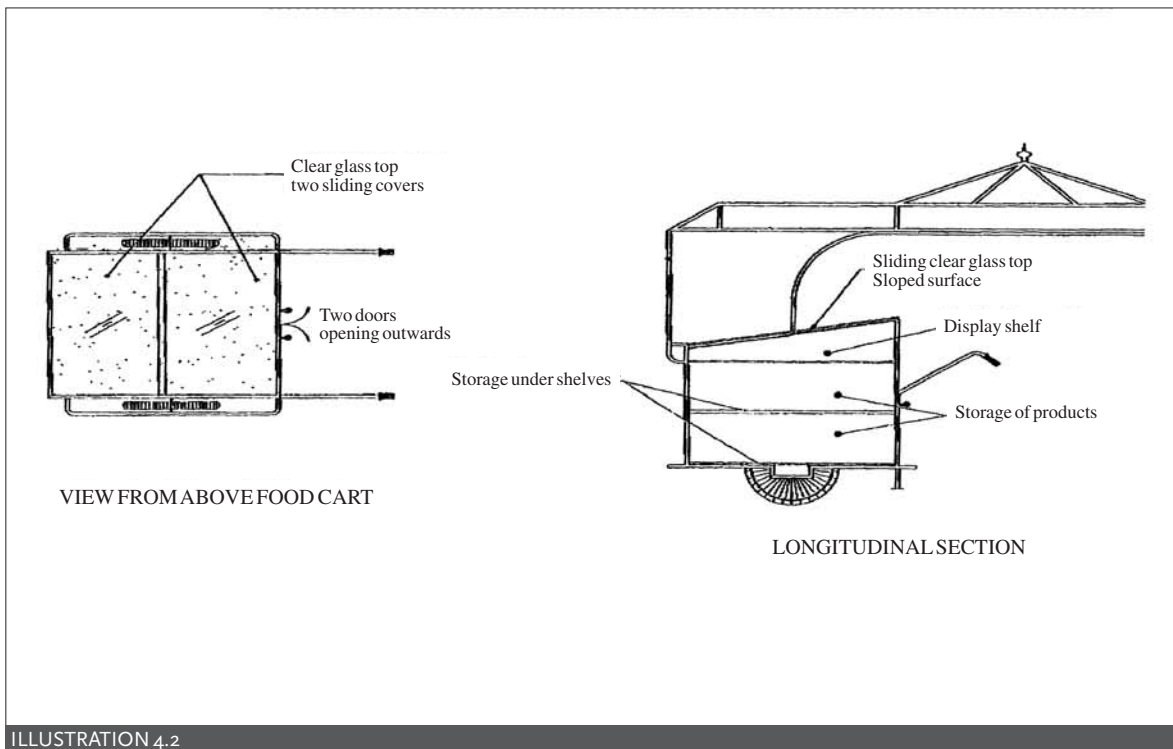
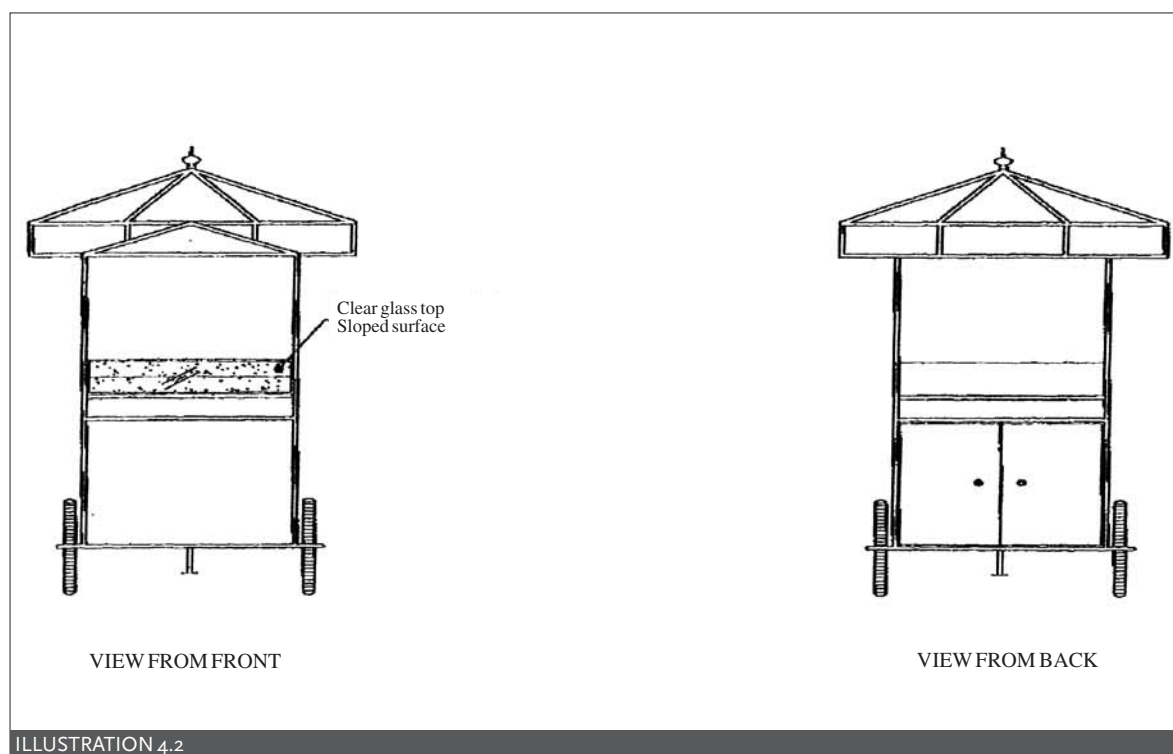

ILLUSTRATION 4.2

SOURCE: project TCP/SEN/8822 (A)

FOOD CART WITH COVER AND GLASS PANELLED CABINET FOR FOOD PROTECTION



SOURCE: project TCP/SEN/8822 (A)

FOOD CART WITH COVER AND CLOSED CONTAINER FOR BEVERAGES

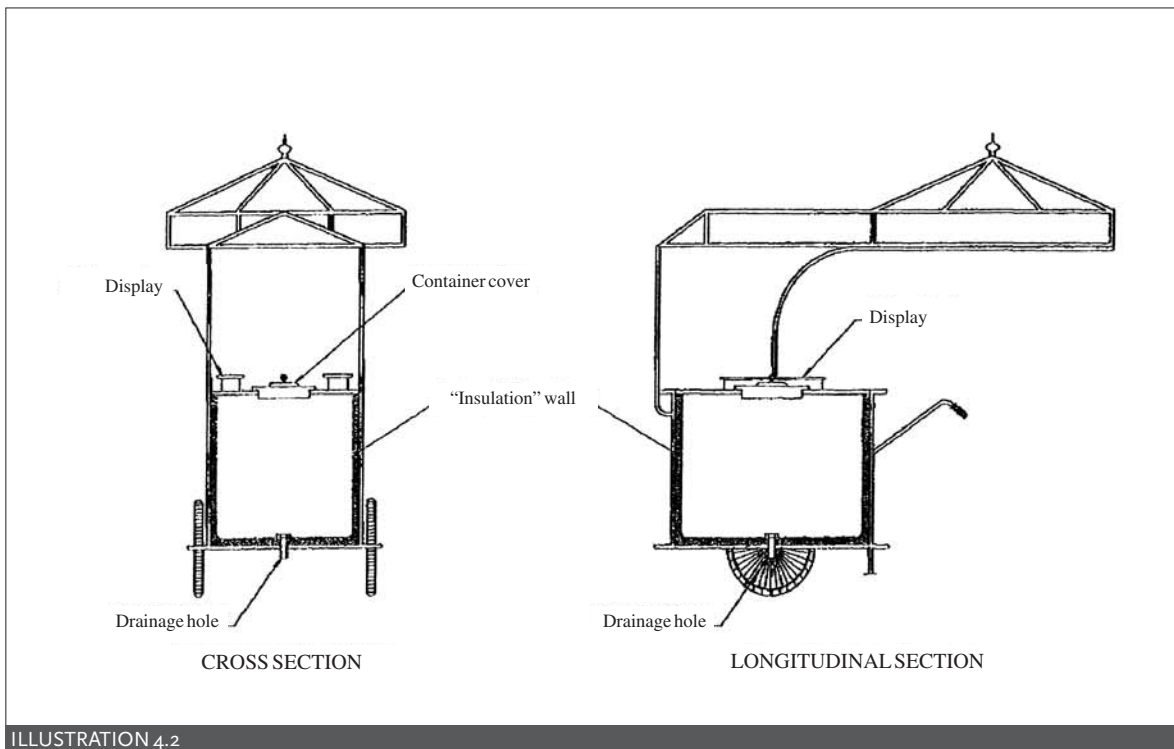

SOURCE: project TCP/SEN/8822 (A)

Annex 4

CLEANING AND DISINFECTING FOOD PREMISES

RISKS OF CONTAMINATION OF FOOD PREMISES

Quality of hygiene in the cooking area requires spotlessly clean surfaces. As no food is sterile, the entire area and equipment can be contaminated by inoffensive or dangerous germs during the work period. It is therefore essential to clean and disinfect the cooking premises to prevent microbe breeding grounds.

To be effective, disinfection of premises and frequency of cleaning need to be carefully planned, using appropriate products and materials.

FREQUENCY OF CLEANING

(As example, but reference should be made to national regulations, where applicable)

- Ceilings: once every month
- Walls: once or twice a day around the work area; once a week elsewhere
- Work areas, tables: after each use

SHEET N°1: CLEANING GLASS PANES

1. Materials

- Dust cloth
- Cotton cloth
- Chamois leather
- Woollen cloth
- Protection of ground with floor cloth
- Newspaper
- Stepladder
- Newspaper for wiping
- Small brush

2. Products

- Vinegar or product for glass panes
- Alcohol at 90° or for burning

3. Instructions

3.1. Preparation

- Get the materials and products ready
- Ensure safety by closing shutters

3.2. Execution

- Dust the window frame and pane starting from the top
- Clean each pane with a clean cloth, with sufficient cleaning product. Start at the centre of the pane and pay special attention to the corners
- Clean and polish first with a clean cloth, then with chamois leather.

3.3. After

- The dust cloth is thoroughly shaken and washed
- The cleaning cloth is washed and cleaning products are carefully closed.

SHEET N°2: CLEANING PLASTIC CHAIR

1. Every day cleaning

- Dust with cloth or tightly wrung sponge
- Dry
- Remove any dirty mark with sponge, soapy warm water and scouring powder, rinse and dry.

2. Thorough cleaning

2.1. Materials

- Two protective floor cloths
- One brush
- One sponge
- Cleaning cloths

2.2. Products

- Hot water, detergent for plastic, alcohol, wood varnish or wax, liquid soap

3. Instructions

- Wash in a large recipient or with wet cloth or sponge
- Let the detergent react for at least 10 mins.
Soak small objects in solution for 10 mins
- Brush above and below
- Remove difficult marks with scouring powder
- Rinse with hot water and sponge
- Drain on floor cloths
- Dry with clean cloth
- Shine with alcohol on cotton cloth

SHEET N°3: CLEANING WASHROOM: DESCALING AND DISINFECTING

1. Materials

- Bucket, sponge, small brush, jug, rubber gloves, clean cloth

2. Products

- Descaler, chlorine bleach

3. Instructions

- Pour water over stained parts and sprinkle them with descaler
- Leave to react according to descaler instructions
- Rinse, wipe, making sure to wear rubber globes
- Disinfect by pouring pure chlorine bleach at 9 or 120 Chl
- Leave to react

SHEET N°4: EVERY DAY CLEANING OF TOILET

1. Materials

These materials should be used exclusively for cleaning the toilet and toilet tiles. They comprise:

- Bowl brush, jug, sponge, rubber gloves, clean cloths

2. Products

- Scouring powder
- Hot water
- Deodorizer/disinfectant

3. Instructions

- Air the toilet leaving the door and windows open
- Brush
- Fill a jug with water and deodorizer/disinfectant
- Clean (see below)

3.1. For a squat toilet:

- Wet the bowl and sides using the jug
- Sprinkle scouring powder without exaggerating
- Brush with a small toilet brush
- Rinse with the jug
- Flush

3.2. For a seated toilet:

- Flush
- Sprinkle scouring powder without exaggerating
- Brush with bowl brush
- Wash seat, outside and column with sponge
- Leave to dry
- Leave toilet paper if needed and deodorizing block
- Wash tiles
- Leave to dry
- Close windows
- Put everything away clean

SHEET N°5: SWEEPING A ROOM

1. Materials

- Broom
- Shovel
- Small brush
- Dusting cloth

- Bucket or bowl
- Dustbin

2. Products

- Water

3. Instructions

3.1. Preparation

- Open windows
- Have materials handy
- Remove light furniture

3.2. Execution

- Sweep from the corner opposite the door
- First sweep part of the room to the door, then other part keeping to the right of the clean part, sweeping large areas
- Collect dust with shovel and brush and empty into dustbin.

3.3. Ordering

- Replace the furniture
- Wipe dust from the furniture
- Check the work
- Put everything away clean
- Close windows

SHEET N°6: THOROUGH CLEANING OF CEMENT FLOORS

1. Materials

- Broom
- Scrub brush
- Bucket
- Dustbin

2. Products

- Hot water
- Detergent
- White spirit
- Chlorine bleach
- Deodorizer

3. Instructions

- Sweep the wetted floor
- Remove dirt with concentrated hot detergent and use white spirit for oil and fat stains

- Wash thoroughly with soapy hot water and scrub brush
- Rinse with hose or bucket
- Use deodorizer or chlorine bleach for last rinse
- Remove all water with broom and squeegee
- Leave to dry with windows open.

SHEET N°7: EVERY DAY CLEANING OF FLOOR TILES

1. Materials

- Brushes
- Two buckets
- Two floor cloths
- Scrub brush

2. Products

- Water
- Floor detergent
- Chlorine bleach

3. Instructions

3.1. Preparation

- Open windows
- Have materials and products handy

3.2. Execution

- Brush (following above instructions)
- Clean floor tiles by rubbing small surface areas with floor cloth soaked in water with detergent, then rinse with clear water and chlorine bleach as you go along
- Wipe the furniture

3.3. Ordering

- Check the finished work
- Put the material and products away clean
- Rearrange room
- Close windows

SHEET N°8: THOROUGH CLEANING OF FLOOR TILES

1. Materials

- Brushes
- Two floor cloths
- Two recipients
- One scrub brush

2. Products

- Hot water
- Soft soap (one soup spoon/litre)
- Abrasives

3. Instructions

3.1. Preparation

- Remove light movable furniture
- Sweep and gather dust
- Have materials and products handy

3.2. Execution

- Brush floor tiles, beginning with corner opposite door
- Work on small surface areas, gradually moving back into the dry dirty part. For more difficult marks, brush after using abrasive powder
- Soak up dirty water by hand with dry floor cloth as you go along
- Rinse every now and then, and a second time when all brushing is finished. Do this with scrub brush and floor cloth soaked in clear water
- Dry by leaving a draught from the window to the door

3.3. Ordering

- Replace furniture and materials

SHEET N°9: CLEANING PAINTED SURFACES

1. Non-washable surfaces

Remove the dust with a non-fleecy cloth placed on brush or a duster brush (wall, ceiling). Some marks can be removed by rubbing with a binding agent like bread dough.

2. Surfaces with oil paint

Oil paint is waterproof and can therefore be washed. But it will eventually be damaged by the carbonic acid and salts in the water and cleaning products used.

2.1. For painted surfaces slightly dirty

- Dust
- Remove marks with a binding agent

2.2. For painted surfaces moderately dirty

- Prepare sponge, bucket, clear water and light clean non-fleecy cloth
- Softly rub wetted and wrung sponge in the direction of the paint
- Do one small area at a time, beginning from the bottom as water trickling into a wet area spreads without leaving a mark
- Wipe by dabbing and leave to dry.

2.3. For dirty painting

- Prepare slightly soapy water, bucket of clear water and clean non-fleecy cloth

- Work as above, wash, rinse and wipe from the bottom

2.4. For very dirty painting

- Use slightly more detergent in the water or even washing powder
- Rub very dirty areas with a little scouring powder

But thorough cleaning wears the paint away. It is therefore important to act promptly and regularly. The paint should be renewed after two or three washes.

BIBLIOGRAPHY

- CHETEL J-F. CHEFTEL H (1977). *Introduction à la biochimie et à la technologie des aliments. Volume 1, Technique et Documentation – Lavoisier. Paris, France.*
- DIOUF F. (1992). *Contribution à l'étude de la qualité hygiénique des aliments vendus sur la voie publique (AVP) dans la région de Dakar. Thèse de Doctorat d'Etat.*
- DUPIN H., CUQ J-L., MALEWIAK M-I., LEYNAUD-ROUAUD C. BERTHIER A. M. (1992). *Alimentation et nutrition humaines. Edit. ESF, Paris, France.*
- FAO (1992). *Guide des bonnes pratiques de fabrication dans les industries agro-alimentaires. Antananarivo, Madagascar.*
- FAO (1989). *Street foods. A summary of FAO studies and other activities relating to street foods. Rome, Italy.*
- FAO (1988). *Street foods. Report of an FAO Consultation, 5-9 December, Jogjakarta, Indonesia.*
- FAO (1994). *Application du système des points de contrôle critique pour l'analyse des dangers (HACCP) aux aliments vendus sur la voie publique. Rome, Italy.*
- FAO (1995). *Guide de bonnes pratiques hygiéniques dans le secteur informel de l'alimentation, Rome, Italy.*
- FAO (2001). *Système de qualité et de sécurité sanitaire des aliments: manuel de formation sur l'hygiène alimentaire et le système d'analyse des risques points critiques pour leur maîtrise (HACCP). Rome, Italy.*
- FAO (1995). *Code d'usages en matière d'hygiène pour la préparation et la vente des aliments sur la voie publique (Norme régionale – Amérique latine et Caraïbes). Codex Alimentarius Commission. Rome, Italy.*
- FAO-WHO (1994). *Fruits et légumes frais tropicaux. Codex Alimentarius, volume 5B. Rome, Italy.*
- FAO-WHO (1994). *Viandes et produits à base de viande y compris les bouillons et consommés. Codex Alimentarius, volume 5B. Rome, Italy.*
- FELLOWS P. and HIDELLAGE V., (1993). *Hygiène et production alimentaire. Manuel destiné aux petits producteurs, sur les règles d'hygiène pour la production et l'emballage des produits alimentaires. Coédition CTA/IF, 45 p, CTA n° 2551.*
- KOUADIO L. (1994). *Promotion et contrôle du secteur informel de l'alimentation à Abidjan, Côte d'Ivoire.*
- Ministry of Public Health in collaboration with FAO (1995). *Manuel d'hygiène alimentaire dans le secteur de informel de l'alimentation. Technical Paper TPC/ZAI/2355 (A), Kinshasa, Zaire.*
- NAGO (1992). *Street foods in West Africa. FAO, Rome, Italy.*
- FAO (1994). *L'alimentation de rue en Afrique de l'ouest. Rapport final sur le secteur informel de l'alimentation, 21/25 November 1994. Cotonou, Benin.*
- WHO (1980). *Directives pour l'établissement ou le renforcement de programmes nationaux de surveillance de la contamination des produits alimentaires. Geneva, Switzerland.*
- WHO (1992). *Principales normes de salubrité applicables aux aliments vendus sur la voie publique. Geneva, Switzerland.*
- WHO (1990). *Guide pour la formation en nutrition des agents de santé communautaire. Geneva, Switzerland.*

WONE D.H., NDIAYE S. (2000). *Formation sur l'hygiène et la qualité des aliments. Formation faite à l'intention des restauratrices, restaurateurs et étalagistes à l'ENFEFS 27 March – 12 May 2000, Dakar, Senegal.*

FAO-FBFI (1990). *Training programme for women on the safe production and sale of street foods. From 11 to 26th February, 1989. Ibadan, Nigeria.*

FAO (1994). *Microbiologie et Hygiène Alimentaire. Numéro spécial, Actes du Séminaire FAO/AAMHA/FMS sur le thème Recherche des germes pathogènes dans les aliments. Rome, Italy.*

FAO (1999). *Food, Nutrition and Development. Field Programme Management, Rome, Italy.*

This training manual on good hygienic practices in the preparation and sale of street food is aimed at trainers working with informal street food operators in Africa, whether in support services or as food safety inspectors. It describes good hygienic practices in a context that sorely lacks the resources and infrastructure required of operators in the formal agri-food sector. The manual therefore strives to be pragmatic. It has four parts: an introduction defining the very specific context of its utilization; a second part identifying major sources of food contamination and practices with risk; a third part providing a glossary, practical exercises, illustrations and posters as key training aids; and a final section with technical fact sheets intended to modify and enrich the basic training modules with detailed practical information and concrete examples from FAO projects in the sector.

ISBN 978-92-5-105583-0



A0740E/1/06.09/1000