

## Preface

This teaching module has been developed as a tool for providing regulators with practical training in GM food safety assessment. The specific safety assessment approach discussed in this text is based on the Canadian regulatory framework for biotechnology products and on Health Canada policy. Nonetheless, the concepts are consistent with those described in international consensus documents produced by the Organization for Economic Cooperation and Development (OECD), the World Health Organization (WHO) and the Food and Agriculture Organization (FAO) of the United Nations.

In order to provide some insight into the type of data usually presented in support of a GM food evaluation, a case study of genetically engineered soybean (*Glycine max*) event GTS 40-3-2 and its progeny has been developed. The content of the study includes excerpts from applications for food safety assessment submitted to regulatory authorities in Canada, the United Kingdom (UK), and the United States (US).

### A note on quality standards for documentation

The evaluation of an application for a GM food safety assessment is comparable to the peer review of a manuscript for publication in a scientific journal. Accordingly, the quality of the text and data presented must be commensurate with this. Experimental procedures should be described in sufficient detail (or referenced accordingly) so that the methodology can be repeated. Spelling and usage should be standard and laboratory jargon avoided. It is recommended that international standards for nomenclature be adopted, such as those described in the International Union of Biochemistry and Molecular Biology's Biochemical Nomenclature and Related Documents [(1992) 2nd Ed. Portland Press, Inc., Chapel Hill, NC ], which contains the International Union of Biochemistry rules of nomenclature for amino acids, peptides, nucleic acids, polynucleotides, vitamins, co-enzymes, quinones, folic acid and related compounds, corrinoids, lipids, enzymes, proteins, cyclitols, steroids, carbohydrates, carotenoids, peptide hormones, and human immunoglobulins. Correct chemical names should be given and strains of organisms should be specified. Trade names should be identified. Système International (SI) units and symbols should be used whenever possible.

Illustrations, tables and figures must be clear and legible. Original drawings, high-quality photographs or laser prints are acceptable; poor-quality reproductions that often result from photocopying prints are not. In particular, reproductions of gels or blots must be of sufficient quality to clearly show the described results.

### Disclaimer

Monsanto Inc. has generously consented to the use of the information provided in various of their regulatory submissions for event GTS 40-3-2 as a training tool. It must be noted, however, that in order to enhance the utility of the case study as a training tool, liberties were taken with the information provided in the original applications. Certain information has been reduced to summaries and the data as presented in the case study are only a subset of that actually submitted. The case study in no way constitutes a complete application nor is it to be considered a complete safety assessment. To that end, the use of this information in the form of a training tool does not constitute an endorsement of the information or product nor should it be considered a reflection of any of the original submissions.

### Description of the recombinant-DNA plant

Soybean is grown as a commercial crop in over 80 countries, with a combined harvest of 162 million metric tonnes. The major producers of soybeans in 2000 were the United States, Brazil, China, Argentina, India, Canada and Paraguay. Soybean is grown primarily for its seed, which has many uses in the food and industrial sectors, representing one of the major sources of edible vegetable oil and of proteins for livestock feed use.

A major food use of soybean in North America and Europe is as purified oil, used in margarines, shortenings, and cooking and salad oils. It is also a major ingredient in food products such as tofu, tempeh, soya sauce, simulated milk and meat products, and is a minor ingredient in many processed foods. Soybean meal is used as a supplement in feed rations for livestock.

Weeds are a major production problem in soybean cultivation. Typically, weeds are managed using a combination of cultural (*e.g.* seed bed preparation, using clean seed, variety selection, and planting date) and chemical controls. Depending on the production

area and the prevalent weed species, herbicides may be applied before planting (e.g. pendimethalin, trifluralin, metribuzin), after planting but before emergence (e.g. pendimethalin, linuron, imazethapyr), and/or after emergence (e.g. bentazon, acifluorfen, fomesafen). Commonly, several different herbicides are required to adequately control weeds in soybean fields.

The soybean line GTS 40-3-2 was developed to allow for the use of glyphosate, the active ingredient in the herbicide Roundup®, as a weed control option. This genetically engineered soybean line contains a form of the plant enzyme 5-enolpyruvylshikimate-3-phosphate synthase (EPSPS) that allows GTS 40-3-2 to survive the otherwise lethal application of glyphosate. The EPSPS gene put into GTS 40-3-2 was isolated from a strain of the common soil bacterium *Agrobacterium tumefaciens* called CP4; the form of EPSPS enzyme produced by this gene is tolerant to glyphosate.

The EPSPS enzyme is part of an important biochemical pathway in plants called the shikimate pathway, which is involved in the production of aromatic amino acids and other aromatic compounds. When conventional plants are treated with glyphosate, the plants cannot produce the aromatic amino acids needed to grow and survive. EPSPS is present in all plants, bacteria, and fungi. It is not present in animals, which do not synthesize their own aromatic amino acids. As the aromatic amino acid biosynthetic pathway is not present in mammals, birds or aquatic life forms, glyphosate has little if any toxicity for these organisms. The EPSPS enzyme is naturally present in foods derived from plant and microbial sources.

GTS 40-3-2 was developed by introducing the CP4 EPSPS gene into a commercial soybean variety using particle-acceleration (biolistic) transformation. The glyphosate tolerance trait expressed in GTS 40-3-2 has since been transferred into more than one thousand commercial soybean varieties by traditional breeding techniques.

GTS 40-3-2 has been tested in field trials in the United States, Central and South America, Europe, and Canada since 1991. Data collected from over 150 field trials conducted over a three-year period prior to commercialization in the United States demonstrated that GTS 40-3-2 did not differ significantly from conventional soybeans in morphology, seed production (yield), agronomic characteristics (such as time to flowering and pod set, or vigor) and tendency to weediness. GTS 40-3-2 did not negatively affect beneficial or nontarget organisms, and was not expected to impact on threatened or endangered species.

**Table 1. Regulatory approval status of glyphosate tolerant soybean event GTS-40-3-2**

Country	Environment (year)	Food and/or feed (year)	Marketing (year)
Argentina	1996	1996	
Australia		2000	
Brazil	1998	1998	
Canada	1995	1996	
China		2004	
Czech Republic		2001	2001
European Union			1996
Japan	1996	1996	
Korea		2000	
Mexico	1998	1998	
Philippines		2003	
Russia		1999	1999
South Africa	2001	2001	
Switzerland		1996	
Taiwan		2002	
United Kingdom		1996	
United States	1994	1994	
Uruguay	1997	1997	

Soybean does not have any weedy relatives with which it can crossbreed in the continental United States or Canada. Cultivated soybean can naturally cross with the wild annual species *G. soja*, however *G. soja*, which occurs naturally in China, Korea, Japan, Taiwan and the former USSR, is not naturalized in North America. Additionally, soybean plants are almost completely self-pollinated and reproductive characteristics such as pollen production and viability were unchanged by the genetic modification resulting in GTS 40-3-2. It was therefore concluded that the potential for transfer of the glyphosate tolerance trait from the transgenic line to soybean relatives through gene flow (outcrossing) was negligible in managed ecosystems, and that there was no potential for transfer to wild species in Canada and the continental United States.

The food and livestock feed safety of GTS 40-3-2 soybean was established based on: the evaluation of the similarity of the structure and function of CP4 EPSPS protein to this same enzyme naturally present in foods and livestock feeds, the fact that CP4 EPSPS protein constitutes a small amount of the protein in GTS-40-3-2 soybeans so there is little dietary exposure, the lack of toxicity or allergenicity of EPSPS proteins from plants, bacteria and fungi, and by direct laboratory studies of the CP4 EPSPS protein. Comparative analyses of key nutrients, including proximates (e.g. protein, fat, fibre,

ash, and carbohydrates), as well as antinutrients between GTS 40-3-2 soybeans and conventional soybeans did not reveal any significant differences. Feeding studies with rats, broiler chickens, cows, and fish further supported the safety and nutritional quality of GTS 40-3-2 as human food and livestock feed.

Event GTS 40-3-2 received its first regulatory approval in the US in 1994 (US Department of Agriculture), and has since been approved for environmental release and use in livestock feed and/or human food in 17 countries and the European Union (Table 1). In 1996, glyphosate tolerant soybeans were planted on less than 5% of the US soybean acreage. In the 2000 growing season, 54% of the soybeans – approximately 40 million acres of the 75.4 million acres of soybeans grown in the United States – were glyphosate tolerant. In Argentina, where the adoption rate is estimated at 95%, glyphosate tolerant soybeans were grown on over 20 million acres in 2000. Globally, glyphosate tolerant soybeans made up 58% of all transgenic crops grown in 2000.

### Description of the host plant and its use as food

The genus *Glycine* Willd. is a member of the family Leguminosae, subfamily Papilionoideae, and the tribe Phaseoleae. The genus *Glycine* is of Asian and Australian origin (Lackey, 1981). *Glycine* is divided into two subgenera, *Glycine* and *Soja* (Moench) F. J. Herm. The subgenus *Glycine* consists of 12 wild perennial species (Hymowitz *et al.* 1991) with wide distribution patterns: Australia, South Pacific Islands, West Central Pacific Islands, China, Papua New Guinea, Philippines, and Taiwan (Hermann, 1962; Newell & Hymowitz, 1978; Hymowitz & Newell, 1981; Grant *et al.* 1984a, 1984b; Tindale 1984, 1986a, 1986b). The subgenus *Soja* includes the cultivated soybean, *G. max* (L.) Merrill, and its nearest wild relative, *G. soja* Sieb. and Zucc., that has been found in China, Taiwan, Japan, Korea, and the former USSR. Both of these species are annuals.

Soybean is a cultivated species of the legume family. Soybeans grow on erect, bushy annual plants, 0.3 - 1.2 metres high with hairy stems and trifoliate leaves. The flowers are small in axillary racemes, usually white or purple. The male and female floral organs are enclosed within the corolla. The seeds are produced in pods, usually containing three spherical to oval seeds weighing 0.1–0.2 g. More detailed descriptions of soybean morphology can be found in Hermann (1962) and Carlson & Lerston (1987).

*Glycine* is the only genus in the Phaseoleae where species have diploid chromosome numbers of 40 and 80 but not 20. The unique chromosome number of *Glycine* is probably derived from diploid ancestors with base number 11, which have undergone aneuploid loss to base number 10 (Lackey 1988). In the legumes, only 10 of 71 genera are considered completely polyploid, *Glycine* is one of these (Senn, 1938). The soybean should be regarded as a stable tetraploid with diploidized genomes (Gurley *et al.* 1979; Lee & Verrna 1984; Skorupska *et al.* 1989).

Soybean is native to China. Early Chinese history refers to soybeans in books written over 4500 years ago (Hymowitz & Singh 1987). Soybean is believed to have been domesticated in the eastern half of northern China around the 11th century B.C. or earlier (Hymowitz 1970), and its cultivation subsequently extended throughout south-east Asia. Soybean is believed to have been introduced into Western Europe in the 18th century (Wolf 1983), though Europe today is a minor producer of soybean, producing less than 2% of the world's production (Oil World Annual 1992). Soybean was introduced into the USA in 1765 (Hymowitz & Harlan 1983), primarily as a forage crop grown for hay and silage. Successful use of soybean as an oilseed in Europe from 1900 to 1910 promoted interest in its use in the USA. Even though interest in soybean production was on the increase during the 1920s and 1930s, most soybean acres were used for forage. The first U.S cultivars selected from planned cross-pollinations were released in the 1940s. Cultivars selected from the first populations formed by hybridization were used as parents to form populations for additional cycles of selection. The process of utilizing superior progeny from one cycle of selection as parents to form populations for the next cycle continues up to the present time (Burton 1987).

In the United States, there has been a rapid expansion in the cultivation of soybean over the past fifty years. Soybean production regions in the USA are concentrated in the Midwest and in the Mississippi Valley (Hazera & Fryar 1981). Apart from the United States (59.8 million metric tons in 1992/93), the principle soybean production areas are now in Brazil (21.3 MT), Argentina (11.7 MT), the Peoples Republic of China (9.7 MT) and India (USDA 1993). The main soybean producing states in Brazil are Rio Grande Do Sul, Parana, and Mato Grosso. In Argentina, the main soybean growing areas are the provinces of Sante Fe, Buenos Aires, and Cordoba.

In Western Europe, soybean is grown mainly in Italy (0.2 -0.4 Mha), in France (0.05 -0.15 Mha), and

occasionally in Greece and Spain. French soybean production is located mainly in the south west and in the Loire valley. In Italy, the soybean production areas are located in the Po valley, particularly in the Po delta and on the coastline of the Veneto region. Europe is one of the major world importers of soybeans.

Soybean is known to contain a number of natural antinutritional components (Rackis 1974; Orthoefer 1978). Trypsin (protease) inhibitors are known to have antinutritive properties in animals fed unprocessed soybeans (Rackis 1974; Rackis *et al.* 1986), although adequate heating inactivates trypsin inhibitors. Soybean hemagglutinin is known to cause red blood cell agglutination *in vitro* (Leiner, 1953), but there is no clear evidence that soybean hemagglutinin plays an antinutritive role (Rackis 1974). The phytoestrogens genistein, daidzein and coumestrol, naturally present in soybeans, are reported to possess a number of biochemical activities in mammalian species, including estrogenic and hypocholesterolemic activities (Wang *et al.* 1990; Murphy 1982). The low molecular weight carbohydrates stachyose and raffinose are known to cause flatus activity (Rackis 1974). Phytic acid (phytate) may reduce mineral availability, since it exists in soybeans as an insoluble, non-nutritionally available calcium-magnesium-potassium complex (Orthoefer 1978; Mohamed *et al.* 1991).

Soybean is also known to be the cause of food allergies in certain individuals (Burks *et al.* 1988). Although the specific soybean proteins that elicit the allergic reactions in soybean have not been uniquely identified or characterised, these proteins have typically been characterised by immunoblotting (Bush *et al.* 1988; Shibasaki *et al.* 1980). Using this technique, specific protein bands have been identified that react with the IgE antibody produced from a pool of sera from soybean sensitive individuals. The number of allergenic proteins varies with sera obtained from individuals in different countries, probably reflecting the extent of consumption of soybean products in the diet. Data from one study in the United States (Bush *et al.* 1988) showed 9 different allergenic proteins using the immunoblot technique, whereas a study in Japan using the same procedure (Shibasaki *et al.* 1980) concluded that there may be as many as 15 different allergenic proteins.

*G. max* L. cv. A5403 ("A5403"), the cultivar that was genetically modified to be tolerant to glyphosate, is a maturity group V cultivar which combines a consistently high yield potential with resistance to races 3 and 4 of the soybean cyst nematode (SCN). It has

purple flowers, grey pubescence and tan pods. Seeds are dull yellow with imperfect black hila. A5403 also combines good standability, excellent emergence, and tolerance to many leaf and stem diseases. A5403 was one of the first group V cultivars with SCN resistance provided to farmers and has received protection under the United States Plant Variety Protection Act. The commercialization strategy for GTS 40-3-2 is to use traditional backcrossing and breeding to transfer the glyphosate tolerance locus from this cultivar to a wide range of varieties and maturity groups of soybeans.

Soybean has a history of safe use as food. Soybeans or processed fractions are consumed in many human food products or animal feeds; soybean is one of the world's largest sources of plant protein and oil. Consequently, the characteristics of soybean in general, and more specifically progenitor line A5403, do not warrant analytical or toxicological tests. Typically, soybean breeders make genetic crosses to generate new cultivars with enhanced commercial value, and they evaluate new varieties primarily based on yield, as well as protein and oil content.

## References

- Burton, J. W. (1987). Quantitative genetics: results relevant to soybean breeding, *Agronomy* 16: 211-247.
- Burks, A.W., Brooks, J.R., Sampson, H.A. (1988). Allergenicity of major component proteins of soybean determined by enzyme-linked immunosorbent assay (ELISA) & immunoblotting in children with atopic dermatitis and positive soy challenge. *Journal of Allergies and Clinical Immunology* 81:1135-1142.
- Bush, R.K., Schroeckenstein, D., Meier-Davis, S., Balmes, J., & Rempel, D. (1988). Soybean flour asthma: detection of allergens by immunoblotting. *Journal Allergy and Clinical Immunology* 82: 251-255.
- Carlson, J. B. & Lersten, N. R. (1987). Reproductive morphology. *Agronomy* 16: 95-134.
- Grant, J.E., Brown, A.H.D. & Grace J.P. (1984a). Cytological and isozyme diversity in *Glycine tomentella* Haryata (Leguminosae). *Australian Journal of Botany* 32: 665-677.
- Grant, J.E., Grace, J.P., Brown, A.H.D. & Putievsky, E. (1984b). Interspecific hybridization in *Glycine* Willd. Subgenus *Glycine* (Leguminosae). *Australian Journal of Botany* 32: 655-663.

- Gurley, W.B., Hepburn, & A.G., Key, J.L. (1979). Sequence organization of the soybean genome. *Biochem. Biophys. Acta* 561: 167-183.
- Hazera, J. & Fryar, E. (1981). Regional soybean production since 1960 and the outlook for the 1980s. Economic Research Service USDA F05-305. U.S. Govt. Printing Office, Washington, D.C.
- Hermann, F. J. (1962). A revision of the genus *Glycine* and its immediate allies. United States Department of Agriculture Technical Bulletin 1268: 1-79.
- Hymowitz, T. (1970). On domestication of soybean. *Economic Botany* 24: 408-421.
- Hymowitz, T. & Newell, C. A. (1981). Taxonomy of the genus *Glycine*, domestication and uses of soybeans. *Economic Botany* 35: 272-288.
- Hymowitz, T. & Harlan, J. R. (1983). Introduction of soybeans to North America by Samuel Bowen in 1765. *Economic Botany* 37: 371-379.
- Hymowitz, T. & Singh, R. J. (1987). Soybean Monograph, Soybeans: Improvement, Production, and Uses. (2nd ed.). Wilcox, R. J. ed., pp. 23-48.
- Hymowitz, T., Palmer, R.G. & Singh, R.J. (1991). Cytogenetics of the genus *Glycine*. In Chromosome Engineering in Plants: Genetics, Breeding, Evolution, Part B. Tsuchiya, T. and Gupta, P. K., eds. Elsevier Science Publishers B. V., Amsterdam, pp 53-63.
- Lackey, J. A. (1988). Chromosome numbers in the Phaseoleae (Fabaceae:Faboideae) and their relation to taxonomy, *American Journal of Botany* 67: 595-602.
- Lackey, J. A. (1981). Phaseoleae DC. In Advances in Legume Systematics, Part I. Pohill, R. M. and Raven, R.H. eds. Royal Botanic Gardens, Kew, pp.301-327.
- Lee, J. S. & Verma, D.P.S. (1984). Structure and chromosome arrangement of leghemoglobin genes in kidney bean suggest divergence in soybean leghemoglobin gene loci following tetraploidization. *EMBO J.* 3: 2745-2752.
- Leiner, I. E. (1953). Soyin, a toxic protein from the soybean. I. inhibition of rat growth. *Journal of Nutrition* 49:527-540.
- Mohamed, A.I., Mebrahtu, T., & Rangappa, M. (1991). Nutrient composition and anti-nutritional factors in selected vegetable soybean [*Glycine max* (L.) Merr.]. *Plant Foods for Human Nutrition* 41: 89-100.
- Murphy, P. A. (1982). Phytoestrogen content of processed soybean products. *Food Technology* 36: 60-64.
- Newell, C. A. & Hymowitz, T. (1978). A reappraisal of the subgenus *Glycine*. *American Journal of Botany* 65:168-179.
- Oil World Annual (1992). ISTA Mielke GmbH. Germany
- Orthofer, F. T. (1978). Processing and Utilization. In Soybean Physiology, Agronomy, and Utilization, A. G. Norman, ed. Academic Press, New York. pp. 219-246.
- Rackis, J. J. (1974). Biological and physiological factors in soybeans. *Journal of American Oil Chemists' Society* 51:161A-173A.
- Rackis, J.J., Wolf, W.J., & Baker, E.C. (1986). Protease inhibitors in plant foods: content and inactivation. In Nutritional and Toxicological Significance of Enzyme Inhibitors in Food. M. Friedman, (ed.). Plenum Press, New York. pp. 299-347.
- Senn, H. A. (1938). Chromosome number relationships in the Leguminosae. *Biblio. Genet.* 12: 175-336.
- Shibasaki, M., Suzuki, S., Tajima, S., Nemoto, H., & Kuroume, T. (1980). Allergenicity of major component proteins in soybean. *International Archives of Allergy and Applied Immunology* 61:441-448.
- Skorupska, H., Albertsen, M.C., Langholz, K.D. & Palmer, R.G. (1989). Detection of ribosomal RNA genes in soybean, *Glycine max* (L.) Merr., by in situ hybridization. *Genome* 32: 1091-1095.
- Tindale, M. D. (1984). Two new Eastern Australian species of *Glycine* Willd. (Fabaceae). *Brunonia* 7:207-213.
- Tindale, M. D. (1986a). A new North Queensland species of *Glycine* Willd. (Fabaceae). *Brunonia* 9:99-103.
- Tindale, M. D. (1986b). Taxonomic notes on three Australian and Norfolk Island species of *Glycine* Willd. (Fabaceae:Phaseoleae) including the choice of a neotype of *G. clandestine* Wendl. *Brunonia* 9:179-191.
- United States Department of Agriculture (USDA) (1993). World oilseed situation and outlook. USDA Foreign Agricultural Service, Oilseeds and Products (FOP 4-93).
- Wang, G., Kuan, S.S., Francis, O.J., Ware, G.M. & Carman, A.S. (1990). A simplified HPLC method for the determination of phytoestrogens in soybean and its processed products. *Journal of Agriculture and Food Chemistry* 38:185-190.
- Wolf, W. J. (1983). Edible soybean protein products. In CRC Handbook of Processing and Utilization in Agriculture, Vol. II, Part 2, I. A. Wolff, (ed.). CRC Press, Boca Raton, pp. 23-55.

## Description of the donor organism(s)

### The donor genes

GTS 40-3-2 contains DNA sequences derived from the following donor organisms:

1. *Agrobacterium* sp. strain CP4 EPSPS gene: The C-terminal 1.36 kb 5-enolpyruvylshikimate-3-phosphate synthase gene (CP4 EPSPS) (Barry *et al.*, 1992; Padgete *et al.*, 1993).
2. Cauliflower mosaic virus (CaMV) enhanced 35 S promoter (P-E35S): The CaMV promoter (Odell *et al.* 1985) with the duplicated enhancer region (Kay *et al.*, 1985).
3. *Petunia hybrida* chloroplast transit peptide (CTP): The N-terminal 0.22 kb CTP sequence for the *P. hybrida* EPSPS gene (Shah *et al.*, 1986). The CTP sequence was fused to the N-terminus of the CP4 EPSPS gene to deliver the CP4 EPSPS protein to the chloroplast, the site of EPSPS activity and glyphosate action.
4. *Agrobacterium tumefaciens* 3' untranslated region of the nopaline synthase gene (NOS 3'): The NOS 3' sequence, isolated from the *A. tumefaciens* Ti plasmid, provides the polyadenylation signal for stable expression (Fraley *et al.*, 1983).

None of the inserted sequences are known to have any pathogenic or harmful characteristics.

The following sequences were present on plasmid PV-GMGT04 but were not integrated into the GTS 40-3-2 genome:

1. Neomycin phosphotransferase II encoding bacterial marker gene (*nptII*): The bacterial selectable marker gene, *nptII*, isolated from the prokaryotic transposon, Tn5 (Beck *et al.*, 1982), encodes for the enzyme neomycin phosphotransferase. This enzyme confers resistance to aminoglycoside antibiotics (*e.g.*, kanamycin or neomycin) used for selection of plasmids in *Escherichia coli*. The promoter for this gene is only active in bacterial hosts.
2. *lacZ*: A partial *E. coli lacI* coding sequence, the promoter Plac, and a partial coding sequence for beta-d-galactosidase or *lacZ* protein from pUC119 (Yanisch-Perron *et al.*, 1985).
3. P-MAS: The 0.42 kb TR 2' mannopine synthase promoter region (Velten *et al.* 1984).
4. GUS: the 1.81 kb coding region of the *E. coli* beta-glucuronidase gene (Jefferson *et al.*, 1986). The expression of the gene in plants is used as a scoreable marker for transformation.

5. 7s 3': The 0.43 kb 3' nontranslated region of the soybean 7S seed storage protein alpha subunit (Schuler *et al.*, 1982).
6. FMV 35S: The 0.57 kb figwort mosaic virus 35S promoter (Gowda *et al.*, 1989).

### Potential pathogenicity of the donor organism

Only a single new protein, EPSPS, was introduced into soybean variety A5403. The gene encoding this protein was isolated from a naturally occurring soil bacterium, *Agrobacterium* sp. strain CP4. This donor bacterium is not a food source but is related to microbes commonly present in the soil and in the rhizosphere of plants. All plant, microbial, and fungal food sources contain EPSPS proteins, therefore, this enzyme and its activity are not novel to the food supply. *Agrobacterium* strains have also been reported in a number of human clinical specimens, but it is believed that these clinical *Agrobacterium* isolates occur either as incidental inhabitants in the patient or as contaminants introduced during sample manipulation (Kerstens and De Ley, 1984).

Characteristics of the donor species, *Agrobacterium*, do not warrant analytical or toxicological tests since only the specific, sequenced gene encoding EPSPS was transferred to soybean. Further detailed information concerning the pathogenicity of other donor organisms is not considered relevant to the risk assessment of GTS 40-3-2 since it was established that only the CP4 EPSPS gene was transferred to the soybean host.

### References

- Barry, G., G. Kishore, S. Padgette, M. Taylor, K. Kolacz, M. Weldon, D. Re, D. Eichholtz, K. Fincher, & L. Hallas. (1992). Inhibitors of amino acid biosynthesis: strategies for imparting glyphosate tolerance to crop plants. In: Biosynthesis and Molecular Regulation of Amino Acids in Plants. B. K. Singh, H. E. Flores, and J. C. Shannon (eds.). American Society of Plant Physiologists pp.139-145.
- Beck, E., Ludwig, G., Auerswald, E.A., Reiss, B. & Schaller, H. (1982). Nucleotide sequence and exact localization of the neomycin phosphotransferase gene from transposon Tn5. *Gene* 19, 327-336.
- Fraley, R. T., Rogers, S. G., Horsch, R. B., Sanders, P. R., Flick, J. S., Adams, S. P., Bittner, M. L.,

- Brand, L.A., Fink, C. L., Fry, J. S., Galluppi, G. R., Goldberg, S. B., Hoffman, N. L. & Woo, S. C. (1983). Expression of bacterial genes in plant cells. *Proc. Natl. Acad. Sci. USA* 80, 4803-4807.
- Gowda, S., Wu, F.C. & Shepard, R.J. (1989). Identification of promoter sequences for the major RNA transcripts of figwort mosaic and peanut chlorotic streak viruses (caulimovirus group). *J. Cell. Biochem.* 13D (supplement), 301.
- Jefferson, R.A., Burgess, S.M. & Hirsch, D. (1986).  $\beta$ -glucuronidase from *Escherichia coli* as a gene-fusion marker. *Proc. Natl. Acad. Sci. USA* 83, 8447-8451.
- Kay, R., Chan, A., Daly, M. & McPherson, J. (1987). Duplication of the CaMV 35S promoter sequences creates a strong enhancer for plant genes. *Science* 236, 1299-1302.
- Kerstens, K., & De Ley, J. (1984). In: *Bergey's Journal of Systematic Bacteriology*, Vol. 1. Kreig, N. R. & Holt, J. G. (eds.). Williams and Wilkins, Baltimore. pp. 244-248.
- Odell, J. T., Nagy, F. & Chua, N.H. (1985). Identification of DNA sequences required for activity of the cauliflower mosaic virus 35S promoter. *Nature* 313, 810-812.
- Padgett, S. R., Barry, G.F., Re, D.B., Weldon, M., Eichholtz, D.A., Kolacz, K.H. & Kishore, G.M. (1993). Purification, cloning, and characterization of a highly glyphosate tolerant EPSP synthase from *Agrobacterium* sp. strain CP4. Monsanto Technical Report MSL-12738, St. Louis.
- Schuler, M. A., Schmitt, E.S. & Beachy, R.N. (1982). Closely related families of genes code for alpha and alpha prime subunits of the soybean 7S storage protein complex. *Nucl. Acids Res.* 10, 8225-8244.
- Shah D., Horsch, R., Klee, H., Kishore, G., Winter, J., Turner, N., Hironaka, C., Sanders, P., Gasser, C., Aykent, S., Siegel, N., Rogers, S. & Fraley, R. (1986). Engineering herbicide tolerance in transgenic plants. *Science* 233, 478-481.
- Velten, J., Velten, L., Hain, R. & Schell, J. (1984). Isolation of a dual plant promoter fragment from the Ti plasmid of *Agrobacterium tumefaciens*. *EMBO J.* 3, 2723-2730.
- Yanisch-Perron, C., Vieira, J. & Messing, J. (1985). Improved M13 phage cloning vectors and host strains: nucleotide sequences of the M13mp18 and pUC19 vectors. *Gene* 33, 103-119.

## Description of the genetic modification

### Description of the transformation method

Plasmid DNA was introduced into the genome of *G. max* cv. A5403 by the particle acceleration method (particle gun) as described in McCabe *et al.* (1988) and Christou *et al.* (1988). DNA was precipitated onto microscopic gold particles using a calcium phosphate solution, and dried down under a stream of nitrogen. The coated particles were resuspended in ethanol and spread onto a mylar carrier sheet. The mylar sheet was accelerated by the force of vaporization as 10-15 kilovolts were discharged across a water drop. The mylar hit a stainless steel retaining screen which stopped the flight of the sheet but allowed the continued flight of the DNA coated particles. The particles penetrated the target plant cells where the DNA was deposited and incorporated into the cell chromosome.

The transformed cells were incubated on a plant tissue culture medium containing cytokinin and auxin to induce multiple shoot formation. The DNA utilized included a marker gene encoding the beta-glucuronidase (GUS) protein (Jefferson *et al.* 1986). The expression of the GUS protein was used as evidence of transformation as detected by a staining method in which the GUS enzyme converted the substrate 5-bromo-4-chloro-3-indolyl beta-d-glucuronide into a blue precipitate. The vast majority of the shoots which were regenerated from the shoot tip cells did not contain any added genes, therefore GUS screening was necessary to identify the genetically modified tissue. The positive shoots were grown to maturity, and the resulting progeny were screened for glyphosate tolerance (by herbicide spray test) and gene expression.

### Plasmid PV-GMGT04

Plasmid PV-GMGT04, used to generate line 40-3-2, contained three genes driven by plant promoters: two CP4 EPSPS genes and a gene encoding beta-glucuronidase (GUS) from *E. coli*. PV-GMGT04 is a pUC-Kan vector derived of the high copy *E. coli* plasmid pUC119 (Vieira & Messing 1987) and was constructed by fusing the 1.3 kb *FspI-DraI* pUC119 fragment containing the origin of replication to the 1.3 kb *SmaI-HindIII* Klenow-filled fragment from pKC7 (Rao & Rogers 1979), which contains the *nptII* gene. The *nptII* gene is driven by a bacterial promoter, preventing its expression in plant cells.

Table 2. Summary of genetic elements in PV-GMGT04

Genetic element	Size Kb	Function
P-E35S	0.61	The cauliflower mosaic virus (CaMV 35S) promoter with the duplicated enhancer region.
CTP4	0.22	The N-terminal 0.22 kb chloroplast transit peptide sequence from the <i>Petunia hybrida</i> EPSPS gene.
CP4 EPSPS	1.36	The C-terminal 1.36 kb 5-enolpyruvylshikimate-3-phosphate synthase gene (CP4 EPSPS) from an <i>Agrobacterium</i> species.
NOS 3'	0.26	The 0.26 kb 3' nontranslated region of the nopaline synthase gene.
KAN	1.32	The Tn5 neomycin phosphotransferase type II gene ( <i>nptII</i> ) from the plasmid pKC7. The <i>nptII</i> confers kanamycin resistance.
ori-pUC	0.65	The origin of replication from the high copy <i>E. coli</i> plasmid pUC119.
LAC	0.24	A partial <i>E. coli</i> lacI coding sequence, the promoter Plac, and a partial coding sequence with beta-d-galactosidase or lacZ protein from pUC119.
P-MAS	0.42	The 0.42 kb TR 2' mannopine synthase promoter region.
GUS	1.81	The 1.81 kb coding region of the <i>E. coli</i> beta-glucuronidase gene. The expression of the gene in plants is used as a scoreable marker for transformation.
7S 3'	0.43	The 0.43 kb 3' nontranslated region of the soybean 7S seed storage protein alpha subunit.
CMoVb	0.57	The 0.57kb figwort mosaic virus 35S promoter.

Prior to their combination in a single vector, the CP4 EPSPS and GUS genes were assembled with promoters and 3' sequences in the following steps: the CTP4:CP4 EPSPS fusion was combined with the CMoVb promoter and NOS 3' terminator (Fralely *et al.* 1983) and the GUS gene (already fused to the MAS promoter and 7S 3') in vector pMON13615. The CTP4:CP4 EPSPS fusion was then combined with the E35S (CMoVa) promoter and NOS 3' terminator in plasmid pMON13620 where the entire fusion product was flanked by *HindIII* recognition sequences to facilitate further subcloning. These three elements were then combined in pUC plasmid pMON13639 by subcloning the E35S/CTP4:CP4 EPSPS/NOS 3' fusion product from pMON13620. The *NotI* fragment of pMON13639, which has the CP4 EPSPS and GUS elements, was moved into pMON10081, a derivative of pUC119 which contains the origin of replication (*ori*-pUC) and the *nptII* gene. The resulting vector was PV-GMGT04 (Fig. 1).

Extensive restriction analysis of the plasmid PV-GMGT04 and its progenitor plasmids demonstrated that all of the genetic elements and restriction fragments were correctly assembled and produced the correctly sized DNA fragments (Eichholtz *et al.* 1993). A summary of the genetic elements used to assemble plasmid PV-GMGT04 is presented in Table 2. The cloning performed to construct plasmid PV-GMGT04 was done in nonpathogenic *E. coli* strains LE392, JM101 and MM294.

CP4 EPSPS is a 47.6 kD protein consisting of a single polypeptide of 455 amino acids (Padgett *et al.* 1993). The deduced amino acid sequence is shown in

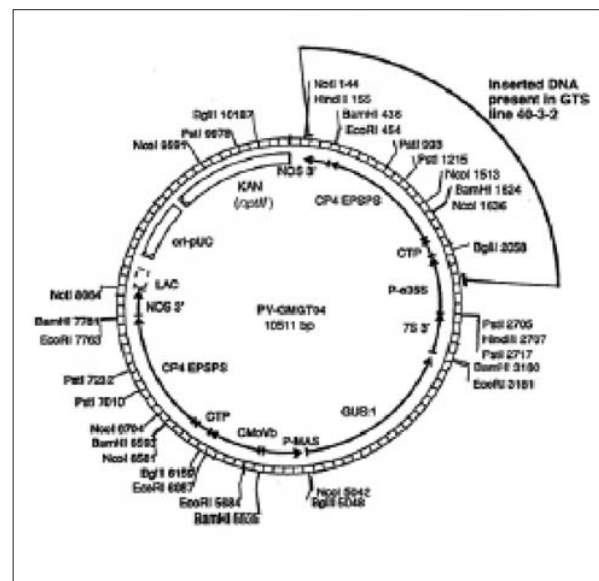


Fig. 1. Schematic representation of plasmid PV-GMGT04 showing restriction enzyme cut sites and the region of plasmid sequence inserted into the host genome.

1	MSHZAASSRPA	TARKSSQLSC	TVRIDGDKSI	SHRSYMFQGL	ASGTRITLGL
51	LEGEEDVINTG	KAMQAMZARI	RKEZDTWIID	GVQNGCLLAD	EADLPQNDAA
101	TCCLRLTMCILV	CVYDFDSTFI	QDASLTKRDM	GRVLNDRLEM	CVQVKSDECD
151	ELDFVTLRQDFK	TPTDITXRVP	NASAQVKSAY	LLAGLNTDGI	TTVIESIMTR
201	DNTEIMLQGF	QANLTVETDA	DQVKTIRLEQ	RKELTQGVLD	VQDFPSSTAF
251	PLVAALLVPG	SDVTILNVLN	NPVTRTGLILT	LQENAGADIEV	INPRLAGGED
301	VADLRVRSST	LEQZTVFEDR	APSNIDYPI	LAVAAAFABQ	ATVNHGLEEL
351	RVKESDRLSA	VANGLKLVG	DCEBZETSLV	VRGRFDCKGL	QIAGCAAVAT
401	HLDRRIAMFP	LVMZLVSEND	VTVDATNIA	TSDFEFMDLM	AGLCAKIELS
451	DTKAA				

Fig. 2. Deduced amino acid sequence of the *Agrobacterium* sp. Strain CP4 EPSPS gene from pMON17081.



Fig. 2. The identification of codons in the gene encoding four peptide sequences obtained directly from the purified enzymatically-active CP4 EPSPS conclusively demonstrated that the gene cloned was the EPSPS gene from *Agrobacterium* sp. strain CP4.

## References

- Arencibia, A.D., Carmona, E.R., Tellez, P., Chan, M.T. Yu, S.M., Trujillo, L.E. & Oramas, P. (1998). An efficient protocol for sugarcane (*Saccharum* spp. L.) transformation mediated by *Agrobacterium tumefaciens*. *Transgenic Research* **7**, 1-10.
- Birch, R.G. (1997). Plant transformation: Problems and strategies for practical application. *Annual Review of Plant Physiology and Plant Molecular Biology* **48**, 297-326.
- Cheng, M, Fry, J.E., Pang, S.Z., Zhou, H.P., Hironaka, C.M., Duncan, D.R., Conner, W. & Wan, Y.C. (1997). Genetic transformation of wheat mediated by *Agrobacterium tumefaciens*. *Plant Physiology* **115**, 971-980.
- Cheng, XY, Sardana, R., Kaplan, H. & Altosaar, I. (1998). *Agrobacterium*-transformed rice expressing synthetic cry1Ab and cry1Ac genes are highly toxic to striped stem borer and yellow stem borer. *Proc. of the Natl. Acad. of Sci.* **95**, 2767-2772.
- Christou, P., McCabe, D.E. & Swain, W.F. (1988). Stable transformation of soybean callus by DNA-coated gold particles. *Plant Physiology* **87**, 671-674.
- Cooley, J., Ford, T. & Christou, P. (1995). Molecular and genetic characterization of elite transgenic rice plants produced by electric-discharge particle acceleration. *Theor. Appl. Genet.* **90**, 97-104.
- Eichholtz, D.A., Barry, G.F., Taylor, M.L. & Padgett, S.R. (1993). Construction of DNA vectors for the production of glyphosate-tolerant soybeans. Monsanto Technical Report MSL-12905, St. Louis, MO.
- Enríquez-Obregón, G.A., Vázquez-padrón, R.I., Prieto-sansonov, D.L., de la Riva, G.A. & Selmán-Housein, G. (1998). Herbicide resistant sugarcane (*Saccharum officinarum* L.) plants by *Agrobacterium*-mediated transformation. *Planta* **206**, 20-27.
- Enríquez-Obregón, G.A., Vázquez-Padrón, R.I., Prieto-Samsónov, D.L., Pérez, M. & Selmán-Housein, G. (1997). Genetic transformation of sugarcane by *Agrobacterium tumefaciens* using antioxidants compounds. *Biotechnología Aplicada* **14**, 169-174.
- Fagard, M. & Vaucheret, H. (2000). (Trans) gene silencing in plants: How many mechanisms? *Annu. Rev. Plant. Physiol. Plant Mol. Biol.* **51**, 167-194.
- Fraley, R.T., Rogers, S.G., Horsch, R.B., Sanders, P.R., Flick, J.S., Adams, S.P., Bittner, M.L., Brand, L.A., Fink, C.L., Fry, J.S., Galluppi, G.R., Goldberg, S.B., Hoffmann, N.L. & Woo, S.C. (1983). Expression of bacterial genes in plant cells. *Proc. Natl. Acad. Sci.* **80**, 4803-4807.
- Gelvin, S.B. (1998). The introduction and expression of transgenes in plants. *Current Opinion in Biotechnology* **9**, 227-232
- Hiei, Y., Ohta, S., Komari, T. & Kumashiro, T. (1994). Efficient transformation of rice (*Oriza sativa*) mediated by *Agrobacterium* and sequence analysis of the boundaries of the T-DNA. *The Plant Journal* **6**, 271-282.
- Hooykaas, P.J.J. & Shilperoort, R.A. (1992). *Agrobacterium* and plant genetic engineering. *Plant Molecular Biology* **19**, 15-38.
- Ishida, Y., Saito, H., Ohta, S., Hiei, Y., Komari, T. & Kumashiro, T. (1996). High efficiency transformation of maize (*Zea mays* L.) mediated by *Agrobacterium tumefaciens*. *Nature Biotechnology* **4**, 745-750.
- Jefferson, R.A., Burgess, S.M. & Hirsch, D. (1986). Beta-glucuronidase from *Escherichia coli* as a gene-fusion marker. *Proc. Natl. Acad. Sci. USA* **83**, 8447-8451.
- Kononov, M.E., Bassuner, B. & Gelvin, S.B. (1997). Integration of T-DNA binary vector "backbone" sequences into the tobacco genome: evidence for multiple complex patterns of integration. *The Plant Journal* **11**, 945-957.
- Matzke, A.J.M. & Matzke, M.A. (1998). Position effects and epigenetic silencing of plant transgenes. *Current Opinion in Plant Biology* **1**, 142-148.
- May, G.D., Afza, R., Mason, H.S., Wiecko, A., Novak, F.J. & Arntzen, C.J. (1995). Generations of transgenic Banana (*Musa acuminata*) plants via *Agrobacterium*-mediated transformation. *Biotechnology* **13**, 486-492.
- McCabe, D.E., Swain, W.F., Martinell, B.J. & Christou, P. (1988). Stable transformation of soybean (*Glycine max*) by particle acceleration. *Bio/Technology* **6**, 923-926.
- Padgett, S.R., Re, D.B., Gasser, C.S., Eichholtz, D.A., Frazier, R.B., Hironaka, C.M., Levine, E.B., Shah, D.M., Fraley, R.T. & Kishore, G.M. (1993). Purification, cloning, and characterization of a highly glyphosate-tolerant EPSP synthase from

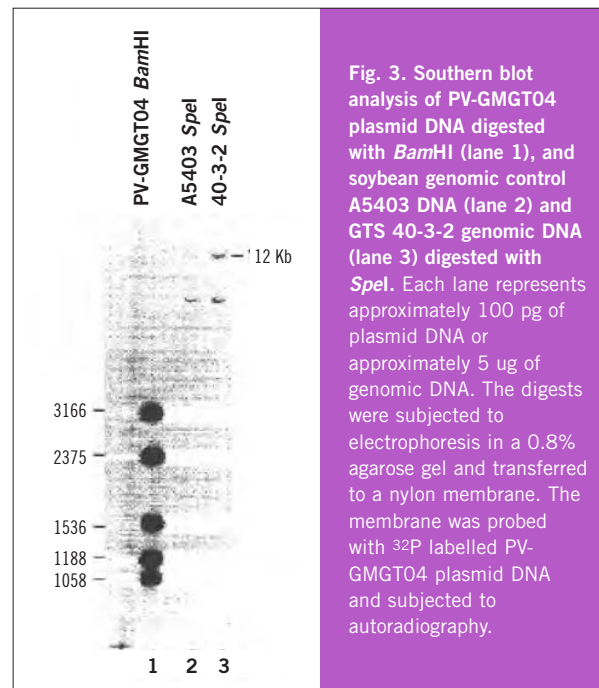
*Agrobacterium* sp. strain CP4. Monsanto Technical Report MSL-12738, St. Louis, MO.

- Powlowski, W.P. & Somers, D.A. (1996). Transgene inheritance in plants genetically engineered by microprojectile bombardment. *Molecular Biotechnology* **6**, 17-30.
- Powlowski, W.P. & Somers, D.A. (1998). Transgenic DNA integrated into the oat genome is frequently interspersed by host DNA. *Proc. Natl. Acad. Sci.* **95**, 12106-12110.
- Ramanathan, V. & Veluthambi, K. (1995). Transfer of non-T-DNA portions of the *Agrobacterium tumefaciens* Ti plasmid pTiA6 from the left terminus of TL-DNA. *Plant Molecular Biology* **28**, 1149-1154.
- Rao, R.N. & Rogers, S.G. (1979). Plasmid PKC7: A vector containing ten restriction endonuclease sites suitable for cloning DNA segments. *Gene* **7**, 79.
- Tempe, J. & Schell, J. *In: Translation of Natural and Synthetic Polynucleotides*, A.B. Legocki, Ed. (Poznan University of Agriculture, Poznan, Poland, 1977) p.416.
- Vieira, J. & Messing, J. (1987). Production of single-stranded plasmid DNA. *Methods in Enzymology* **153**, 3-11.
- Wenck, A., Czako, M., Kanevski, I. & Marton, L. (1997). Frequent collinear long transfer of DNA inclusive of the whole binary vector during *Agrobacterium*-mediated transformation. *Plant Molecular Biology* **34**, 913-922.

## Characterization of the genetic modification

### Characterization of the primary insert

In order to determine the number of insertion sites of PV-GMGT04 DNA in line 40-3-2, genomic DNA isolated from 40-3-2 and control line A5403 (Dellaporta *et al.* 1983) was digested with *SpeI* and subjected to Southern blot analysis (Southern 1975). The blot was probed with <sup>32</sup>P-labelled PV-GMGT04, which does not contain a restriction site for *SpeI*. Line 40-3-2 DNA produced a single band of high molecular weight DNA that was absent from the control lane (Fig. 3, lanes 2 and 3). These results suggest that PV-GMGT04 DNA is present at a single site in 40-3-2 genomic DNA. Three additional bands of lighter intensity, present in both the 40-3-2 and A5403 lanes, represent naturally-occurring cross-hybridizing sequences in A5403 soybean.



**Fig. 3.** Southern blot analysis of PV-GMGT04 plasmid DNA digested with *Bam*HI (lane 1), and soybean genomic control A5403 DNA (lane 2) and GTS 40-3-2 genomic DNA (lane 3) digested with *SpeI*. Each lane represents approximately 100 pg of plasmid DNA or approximately 5 ug of genomic DNA. The digests were subjected to electrophoresis in a 0.8% agarose gel and transferred to a nylon membrane. The membrane was probed with <sup>32</sup>P labelled PV-GMGT04 plasmid DNA and subjected to autoradiography.

The number of insertion sites and the approximate size of inserts were also investigated by Southern blot analyses using three restriction enzymes that cut within the plasmid PV-GMGT04. Genomic DNA from GTS 40-3-2 and A5403 was digested with *Bam*HI, *Hind*III, and *Eco*RI, and the separated fragments probed with <sup>32</sup>P-labelled PV-GMGT04.

Table 3 lists the predicted sizes of fragments of *Bam*HI, *Hind*III and *Eco*RI digested PV-GMGT04, as well as the sizes of the bands observed for 40-3-2 (Fig. 4, lanes 3, 5 and 7). For *Bam*HI-digested PV-GMGT04 (Fig. 4, lane 1) the observed 1.2 kb fragment corresponded to an anticipated 1.2 kb fragment of PV-GMGT04 (Fig. 4, lane 3). The two additional hybridizing bands (Fig. 4, lane 3), which do not match in size to any band in the *Bam*HI PV-GMGT04 digest, are border fragments which contain part of the plasmid DNA attached to plant genomic DNA. *Hind*III cuts twice within PV-GMGT04 but only one hybridizing band was detected for 40-3-2 (Fig. 4, lane 5), indicating that at least one or both *Hind*III sites were absent from the insert. As shown in Fig. 1, an *Eco*RI site is present in the 1.2 kb CP4 EPSPS *Bam*HI fragment of PV-GMGT04. Two bands were observed for *Eco*RI digested 40-3-2 DNA (Fig. 4, lane 7), indicating that *Eco*RI cuts once within the CP4 EPSPS gene of the insert to generate two border fragments. The presence of no more than two border fragments for *Bam*HI, *Hind*III and *Eco*RI digested 40-3-2 DNA confirms the presence of a single insertion site. The total size of the hybridizing bands was less than 6 kb in the three

digestions, indicating that a PV-GMGT04 fragment of less than 6 kb was integrated into the plant genome.

A combination of PCR and Southern blot analyses was used to characterize the single insert present in line 40-3-2.

### ori-pUC

To analyze for the presence of the pUC origin of replication (*ori*-pUC), oligonucleotides corresponding to the 5' and 3' sequences of *ori*-pUC were used in a polymerase chain reaction (PCR) analysis (Mullis & Faloona 1987; McPherson *et al.* 1991) of genomic DNA from 40-3-2, 61-137 and A5403. 61-137 is an experimental glyphosate tolerant soybean line, transformed with the plasmid PV-GMGT04 and known to contain sequences corresponding to the *ori*-pUC region. As shown in Fig. 5, DNA from line 61-137 and

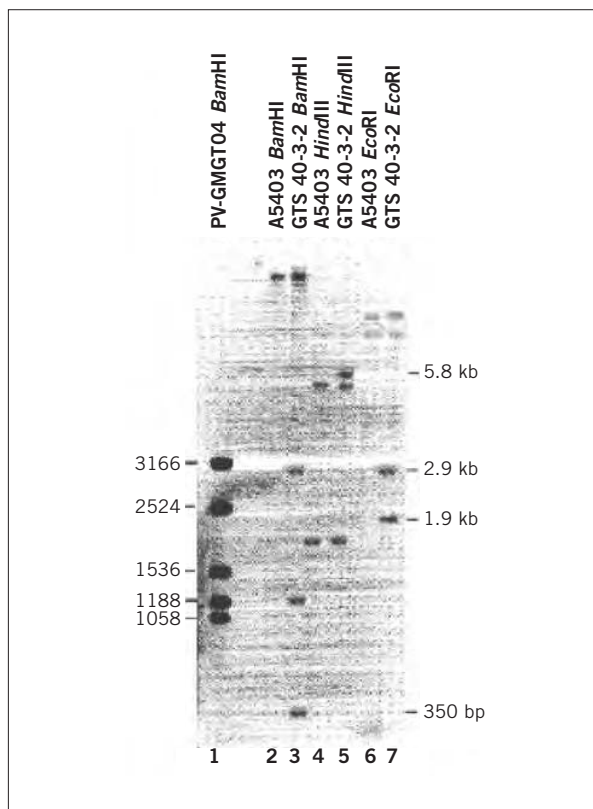
PV-GMGT04 produced bands of the expected size of 671 bp (lanes 4 and 5). No bands of this size were observed for either 40-3-2 or the control A5403 (lanes 2 and 3).

These results established that an intact *ori*-pUC element was not present in line 40-3-2.

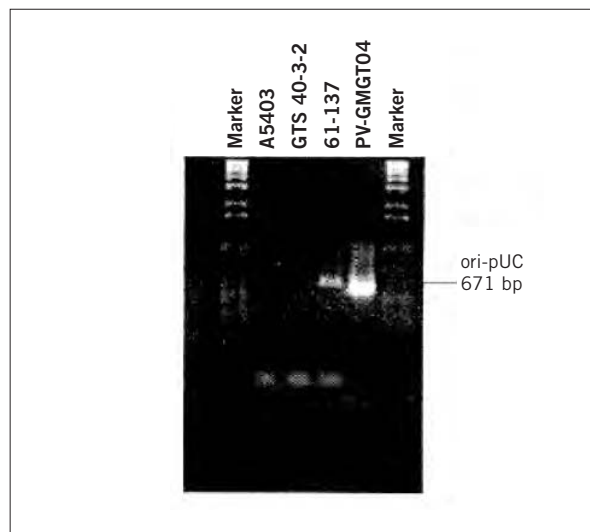
**Table 3. Restriction analysis of line 40-3-2 and plasmid PV-GMGT04**

Restriction fragments size (bp) <sup>1</sup>					
BamHI		HindIII		EcoRI	
Plasmid	40-3-2	Plasmid	40-3-2	Plasmid	40-3-2
3166		7959		3202	
	2900		5800		2900
2375		2552		2727	
1536				2503	
1188	1200				1900
1058				1646	
	350			403	

1. The values for the plasmid PV-GMGT04 are based on calculated sizes (Fig. 1). The values for 40-3-2 are estimated from gel migration relative to molecular weight markers (Fig. 4). Bands present in both the experimental and control lanes are not listed.



**Fig. 4.** Southern blot analysis of PV-GMGT04 DNA digested with *Bam*HI (lane 1), soybean A5403 control DNA digested with *Bam*HI (lane 2), *Hind*III (lane 4) and *Eco*RI (lane 6), and 40-3-2 DNA digested with *Bam*HI (lane 3), *Hind*III (lane 5) and *Eco*RI (lane 7). Each lane represents approximately 100 pg of plasmid DNA or approximately 5 ug of genomic DNA. DNA was subjected to electrophoresis through a 0.8% agarose gel and transferred to a nylon membrane. The membrane was probed with <sup>32</sup>P labelled PV-GMGT04 plasmid DNA and subjected to autoradiography.



**Fig. 5.** PCR analysis of line 40-3-2 genomic DNA for *ori*-pUC. Genomic DNA from control line A5403 and event 40-3-2 were analyzed using PCR to determine the presence or absence of the pUC origin of replication. The positive DNA controls were PV-GMGT04 plasmid DNA and 61-137, a soybean line containing *ori*-pUC. A 5' and a 3' oligonucleotide were made identical to the 5- and 3' ends of *ori*-pUC. Reactions were done in 100 ul total volume containing 100 pg of each oligo, 1 ug template, dNTPs at 200 uM, 10 units of Taq DNA Polymerase (Perkin-Elmer, Norwalk, CT). The PCR amplification cycle consisted of 94°C denaturation for 1.5 min, 55°C annealing for 1.5 min, and a 72°C extension for 3 min. The cycle was repeated 24 times. Products were separated on a 1.25% agarose gel and visualized by ethidium bromide staining. The lower bands at the bottom of the gel are unused oligos.

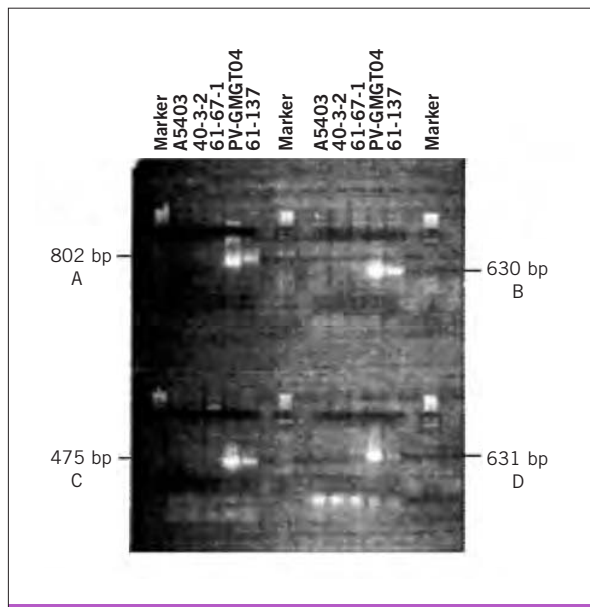
*nptII*

PCR analysis was also used to test for the presence of the *nptII* gene in line 40-3-2. Four oligonucleotides were used: 5' and 3' oligonucleotides corresponding to the ends of the *nptII* gene, and 5' and 3' oligonucleotides internal to the gene. Genomic DNA from 40-3-2, 61-137 and A5403, and PV-GMGT04 plasmid DNA was used as template. The oligonucleotides were used in four combinations: 5' end and 3' end; 5' end and 3' internal; 3' end and 5' internal; and both internal primers. As shown in Fig. 6, PV-GMGT04 (lanes 5 and 11) and 61-137 (lanes 6 and 12) produced the correct size PCR products. Lines 40-3-2 (lanes 3 and 9) and A5403 (lanes

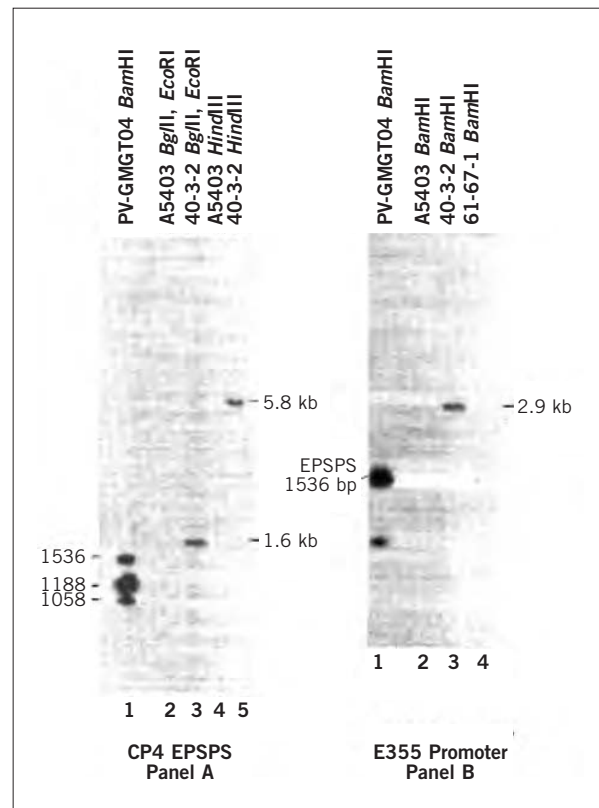
2 and 8) showed none of the predicted *nptII* PCR products. These results established that an intact *nptII* gene was not present in line 40-3-2.

## CP4 EPSPS

Genomic DNA from A5403 and 40-3-2 was digested with *HindIII*, or *BglIII/EcoRI*. The blot was hybridized with a <sup>32</sup>P-labelled probe specific to the CP4 EPSPS coding region. A 5.8 kb band of *HindIII* digested 40-3-2 DNA hybridized with the CP4 EPSPS gene (Fig. 7, Panel A, lane 5), indicating that the CP4 EPSPS gene (or gene fragment) was present in line 40-3-2. This 5.8 kb band was also evident in Fig. 4 (lane 5). The CP4 EPSPS probe



**Fig. 6. PCR analysis of line 40-3-2 genomic DNA for *nptII*.** Soybean genomic DNA from the GTS 40-3-2 was analyzed using PCR to determine the presence or absence of the *nptII* gene. The negative controls were A5403 and 61-67-1, an experimental GTS line negative for *nptII*. Two positive controls were used: PV-GMGT04 plasmid DNA and 61-137, a GTS line positive for *nptII*. Four oligonucleotides were used in this analysis: a 5' and a 3' oligo were made identical to the ends of the gene, and a 5' and a 3' oligo were made identical to internal sequences of the gene: *nptII* 5' (nt 10159 to 10140), *nptII* 5' internal (nt 10005 to 9988), *nptII* 3' end (nt 9357 to 9370), and *nptII* 3' internal (nt 9511 to 9529). The predicted product sizes are: A = 5' end + 3' end, 802 bp; B = 5' end + 3' internal, 630bp; C = 5' internal + 3' internal, 475 bp; and D = 5' internal + 3' end 631 bp. Reactions were done in 100ul total volume, containing 100 pg of each indicated oligo, 1 ug template, dNTPs at 200 uM, 10 units Taq DNA Polymerase (Perkin-Elmer, Norwalk, CT). The PCR amplification cycle consisted of 94°C denaturation for 1.5 min, 63°C annealing for 1.5 min, and a 72°C extension for 6 min. The cycle was repeated 24 times. Products were separated on a 1.25% agarose gel and visualized by ethidium bromide staining. The lower bands at the bottom of each gel are unused oligos.



**Fig. 7. Southern blot analysis with CP4 EPSPS and E35S probes.** PV-GMGT04 plasmid DNA was digested with *BamHI* (lane 1 in both panels). Genomic DNA from A5403 control was digested with *BglIII/EcoRI* (panel A, lane 2), *HindIII* (panel A, lane 4) and *BamHI* (panel B, lane 2). GTS line 40-3-2 DNA was digested with *BglIII/EcoRI* (panel A, lane 3), *HindIII* (panel A, lane 5), and *BamHI* (panel B, lane 3). GTS 61-67-1, a negative control for E35S was digested with *BamHI* (panel B, lane 4). Each lane represents approximately 100 pg of plasmid DNA or approximately 5 ug of genomic DNA. The digests were subjected to electrophoresis in a 0.8% agarose gel and transferred to a nylon membrane. The membranes were probed with <sup>32</sup>P-labelled coding region of CP4 EPSPS (panel A), or E35S promoter (panel B), and then subjected to autoradiography. The smaller mark in lane 1 of panel B is a dot on the blot and not an additional band.

was predicted to hybridize with a 2552 bp band of *Hind*III-digested PV-GMGT04 DNA (Fig. 4.1). No fragment of this size was detected for 40-3-2, indicating that at least one of the PV-GMGT04 *Hind*III sites was not transferred to line 40-3-2. A band of 1.6 kb *Bgl*III/*Eco*RI-digested 40-3-2 DNA (Fig. 7, Panel A, lane 3) hybridized with the CP4 EPSPS probe, indicating that an intact CP4 EPSPS gene was present in 40-3-2.

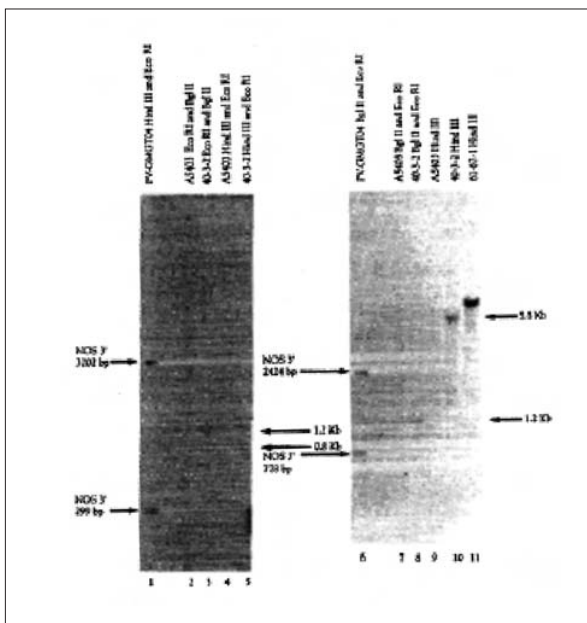
### E35S promoter

A Southern blot was performed using A5403 and 40-3-2 DNA digested with *Bam*HI, and probed with 32P-labelled E35S promoter DNA. The E35S element, or a portion of it, was present in line 40-3-2 (Fig. 7, Panel B, lane 3); a single band of 2.9 kb was detected for 40-3-2, corresponding to the border fragment detected in Fig. 4 (lane 3) and discussed above. Since E35S is located on a 1536 bp *Bam*HI fragment of PV-GMGT04 (Fig. 1), and no fragment of this size was detected for 40-3-2, it is clear

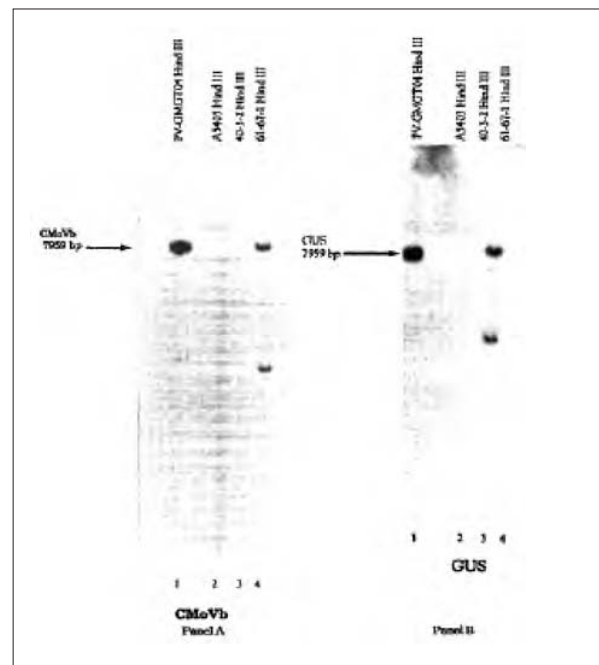
that the *Bam*HI site at nucleotide (nt) 3160 (Fig.1) was not present in line 40-3-2.

### NOS 3'

A Southern blot was performed using A5403 and 40-3-2 DNA digested with *Hind*III, and probed with 32P-labelled NOS 3' terminator DNA. At least a portion of the NOS 3' element is present in 40-3-2 (Fig. 8, lane 10) as a single band of 5.8 kb was detected for line 40-3-2, corresponding to the border fragment detected in Fig. 5.2 (lane 5) and discussed above. A5403 and 40-3-2 DNA was subsequently digested with *Eco*RI/*Bgl*III and *Eco*RI/*Hind*III. A 0.8 kb fragment of *Eco*RI/*Hind*III digested 40-3-2 DNA hybridized with the NOS 3' probe (lane 5) where the map predicted size is 0.3 kb. A 1.2 kb fragment of *Eco*RI/*Bgl*III digested 40-3-2 DNA hybridized to the NOS 3' (lane 3) probe where the predicted size is 0.8 kb. These results indicate that the *Hind*III site at nt 155 and the *Bgl*III site at nt 10187 were not present in the insert of 40-3-2.



**Fig. 8. Southern blot analysis with NOS 3' probe.** PG-GMGT04 plasmid DNA was digested with *Hind*III/*Eco*RI (lane 1) and *Bgl*III/*Eco*RI (lane 6). Genomic DNA from A5403 control was digested with *Eco*RI/*Bgl*III (lanes 2 and 7), with *Hind*III/*Eco*RI (lane 4), and with *Hind*III (lane 9). GTS line 40-3-2 was digested with *Bgl*III/*Eco*RI (lanes 3 and 8), with *Hind*III and *Eco*RI (lane 5) and with *Hind*III (lane 10). GTS line 61-67-1, a positive control for NOS 3' was digested with *Hind*III (lane 11). Each lane represents approximately 100 pg of plasmid DNA or approximately 5 ug of genomic DNA. The digests were subjected to electrophoresis in a 0.8% agarose gel and transferred to a nylon membrane. Both panels were probed with 32P labelled NOS 3' and then subjected to autoradiography.



**Fig. 9. Southern blot analysis with CMoVb and GUS probes.** PV-GMGT04 plasmid DNA was digested with *Hind*III (panels A and B, lanes 1). Soybean A5403 control DNA was digested with *Hind*III (panels A and B, lanes 2). GTS line 40-3-2 DNA was digested with *Hind*III (panels A and B, lanes 3), and GTS line 61-67-1 DNA was digested with *Hind*III (panels A and B, lane 4). Each lane represents approximately 100 pg plasmid DNA or approximately 5 pg of genomic DNA. The digests were subjected to electrophoresis in a 0.8% agarose gel and transferred to a nylon membrane. The membranes were probed with 32P labelled CMoVb promoter (panel A) or the coding region of GUS (panel B) and then subjected to autoradiography.

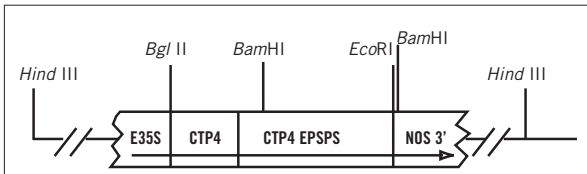


Fig. 10. Predicted DNA insert in soybean event 40-3-2 located on a 5.8 kb *HindIII* restriction fragment.

## CMoVb promoter

A Southern blot was performed using A5403 and 40-3-2 DNA digested with *HindIII*, and probed with <sup>32</sup>P-labelled CMoVb promoter. As shown in Fig. 9, no band was detected for line 40-3-2 (Panel A, lane 3), indicating that the CMoVb promoter DNA is not present in line 40-3-2. GTS line 61-67-1, which contains the CMoVb promoter, provided a positive control (Panel A, lane 4).

## GUS

A Southern blot was performed using A5403 and 40-3-2 DNA digested with *HindIII*, and probed with <sup>32</sup>P-labelled GUS coding region. As shown in Fig. 9, no band was detected for 40-3-2 (Panel B, lane 3), indicating that GUS is not present in this line. GTS line 61-67-1, which contains the GUS gene, provided a positive control (Panel B, lane 4).

## Characterization of the secondary insert

Additional characterization of GTS 40-3-2 was undertaken using a Southern blot method with higher sensitivity than that used in the initial characterizations (Re *et al.* 1993; Kolacz & Padgett 1994; Padgett *et al.* 1996). DNA from event 40-3-2 and the R3 progeny generation (Resnick BC1F2) used to develop commercial varieties was digested with the restriction enzyme *HindIII* and subjected to Southern blot hybridization analysis using a full length CP4 EPSPS coding sequence probe. A5403 control DNA and A5403 control DNA spiked with plasmid PV-GMGT04 DNA were also digested with *HindIII* and used as controls. The results are shown in Fig. 11. A5403 control DNA (lane 2) showed no hybridization bands, as expected, while A5403 control DNA spiked with plasmid PV-GMGT04 DNA (lane 3) produced two bands at ~2.5 kb and ~8.0 kb as predicted from the plasmid map in Fig. 1. Resnick BC1F2 DNA (lane 4) and event 40-3-2 DNA

(lane 5) produced the expected size band at approximately 5.8 kb, which represents the primary, functional insert, as well as a band at approximately 900 bp. There is a slight difference in the migration of the ~900 bp band between the two samples due to variations in DNA quality.

To more clearly define the region of CP4 EPSPS present on the ~900 base pair *HindIII* restriction fragment, genomic DNA extracted from both 40-3-2 and Resnick BC1F2 material was analyzed by Southern blot hybridization with sequential portions of the CP4 EPSPS coding sequence and the NOS 3' transcriptional termination element (see diagram at bottom of Fig. 12). A5403 control DNA, A5403 control DNA spiked with plasmid PV-GMGT04 DNA, Resnick BC1F2 DNA, and 40-3-2 DNA were digested with *HindIII* and included on all Southern blots. Southern blot analyses on the Resnick BC1F2 and 40-3-2 DNA samples performed using the NOS 3' probe and three CP4 EPSPS probes (Probe-1, Probe-2, and Probe-4) generated only the expected band at ~5.8 kb representing the primary, functional insert in

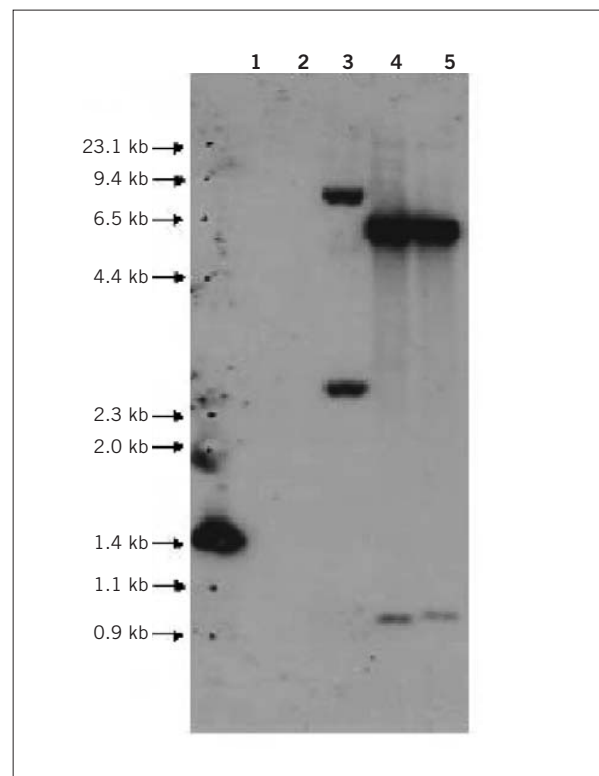
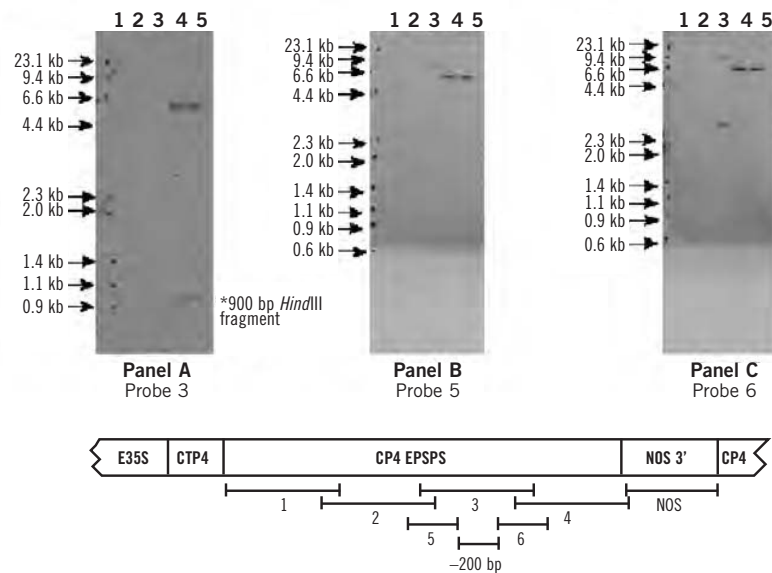


Fig. 11. Southern blot analysis of event 40-3-2. Ten micrograms of genomic DNA extracted from leaf tissue of A5403 control (lane 2), A5403 control spiked with ~15 µg PV-GMGT04 plasmid DNA (lane 3), Resnick BC1F2 (lane 4), and 40-3-2 (lane 5) were digested with *HindIII*. Lane 1 was left blank. The blot was probed with the <sup>32</sup>P-labelled full length CP4 EPSPS coding region. The arrow symbol denotes sizes obtained from MW markers on ethidium stained gel.

**Fig. 12. Southern blot analysis using overlapping CP4 EPSPS probes.** Ten micrograms of genomic DNA extracted from leaf tissue of A5403 control (lane 2), A5403 control spiked with ~15 pg PV-GMGT04 plasmid DNA (lane 3), Resnick BC1F2 (lane 4), and 40-3-2 (lane 5) were digested with *Hind*III. Lane 1 is blank in all panels. Panel A was probed with CP4 EPSPS probe-3, panel B with CP4 EPSPS Probe-5, and panel C with CP4 EPSPS probe 6. The blot in panel A is the result of stripping and reprobing of the blot in Fig. 11. The positions of the probes with respect to the CP4 EPSPS coding sequence and NOS are illustrated on the linear map below the panels with the probes used in panels A, B, and C in bold print. The arrow symbol denotes sizes obtained from MW markers on ethidium stained gel.



soybean event 40-3-2 (data not shown). The only Southern blot on which the ~900 bp *Hind*III restriction fragment was observed in the Resnick BC1F2 DNA and 40-3-2 DNA samples is shown in Fig. 12, Panel A. This blot was probed with CP4 EPSPS Probe-3 (see diagram at bottom of Fig. 12). The blot in Fig. 11 was stripped and reprobed to generate this result, therefore the size of the ~900 bp *Hind*III restriction fragment is again slightly shifted between the two soybean event 40-3-2 samples. Probes designed to overlap the 5' and 3' ends of CP4 EPSPS Probe-3 did not hybridize to the ~900 bp *Hind*III fragment (Fig. 12, Panels B and C). These results indicate that the NOS 3' transcriptional termination element is not present on the ~900 bp *Hind*III restriction fragment, and that the portion of the CP4 EPSPS coding region contained within the ~900 bp *Hind*III restriction fragment is less than 200 bp in length.

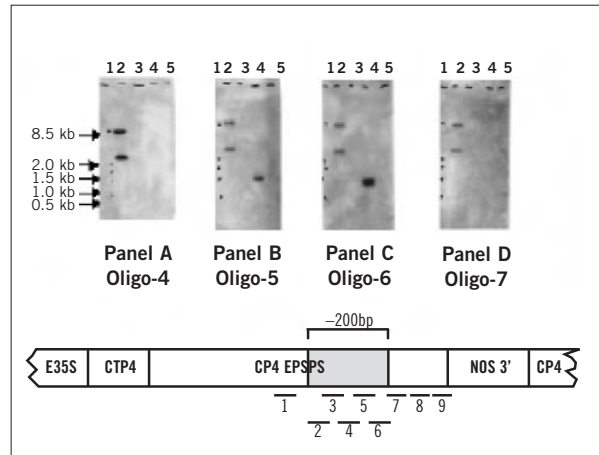
To further delineate the CP4 EPSPS sequence present on the ~900 bp *Hind*III restriction fragment, a pool of cosmid DNA which contained the ~900 bp *Hind*III restriction fragment was digested with *Hind*III, separated by agarose gel electrophoresis and transferred to a nylon membrane. The plasmid vector PV-GMGT04 was used as a positive hybridization control and should result in the visualization of two bands at ~8.0 kb and ~2.5 kb based on the plasmid map (Fig. 1). Several identical blots were hybridized separately with oligonucleotide probes 3'-end labelled with digoxigenin-11-dUTP (see diagram at bottom of Fig. 13). Hybridization of the cosmid DNA was not observed with the oligonucleotide probes Oligo-1, Oligo-2, Oligo-3,

Oligo-4, Oligo-8 and Oligo-9, although the probes did hybridize to the PV-GMGT04 plasmid positive control, indicating that the conditions employed were conducive for hybridization (data not shown). However, oligonucleotide probes Oligo-5 and Oligo-6 did hybridize to the ~900 bp *Hind*III restriction fragment in the DNA extracted from the cosmid DNA (data not shown). The pool of cosmid clones was further screened to isolate single colonies that contained the ~900 bp *Hind*III restriction fragment. The purified cosmid clone 6A was digested with *Hind*III, separated by agarose gel electrophoresis, and transferred to a nylon membrane. The controls were identical to those used in the experiment on the cosmid pool. Hybridization was observed between the oligonucleotide probes Oligo-5 and Oligo-6 with the ~900 bp *Hind*III restriction fragment as was previously observed with DNA prepared from the pool. However, oligonucleotide probe Oligo-7 located immediately 3' of the Oligo-6 probe did not hybridize to the ~900 bp *Hind*III restriction fragment in the cosmid DNA prepared from clone 6A. Oligonucleotide probe Oligo-4, located immediately 5' of Oligo-5 probe and used on the pool of cosmid DNA, also did not hybridize to the ~900 bp *Hind*III restriction fragment (Fig. 13). The two oligonucleotide probes, Oligo-5 and Oligo-6, which did hybridize to the ~900 bp *Hind*III restriction fragment in the DNA from cosmid clone 6A, are contiguous in the CP4 EPSPS coding region and represents a minimum of 53 bp of the maximum 200 bp region expected to be present from previous probe walking experiments on soybean event

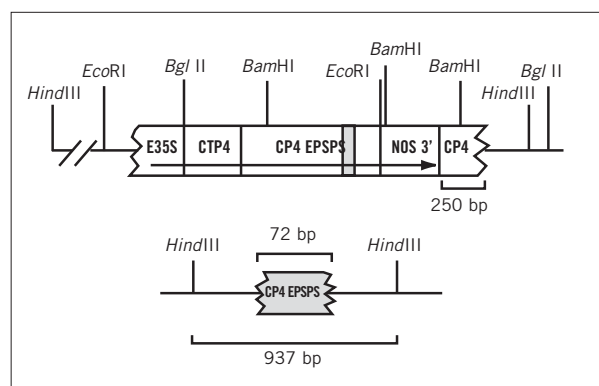
40-3-2 genomic DNA (Fig. 12). In conclusion, the oligonucleotide probe hybridization to the cosmid clones allowed the portion of the CP4 EPSPS sequence present on the ~900 bp *Hind*III restriction fragment to be defined as ~53 bp consisting of sequence which hybridized to the Oligo-5 and Oligo-6 probes (Fig. 13).

Oligo-5 and Oligo-6 (Fig. 13) were used as primers to generate DNA sequence directly from purified cosmid clones 6A and 4B (a second cosmid clone shown to contain a similar insert to 6A) in both the 5' and 3' directions. Multiple primers were then designed to the resulting potential 5' and 3' flanking sequences and paired with Oligo-5 and Oligo-6 primers. PCR products were obtained and subsequently sequenced. The combination of DNA sequence data revealed that 72 bp of CP4 EPSPS (base pairs 855-926, Fig. 1) are located on a 937 bp *Hind*III restriction fragment. No other sequences derived from plasmid PV-GMGT04 (Fig. 1) used in the transformation of soybean event 40-3-2 were identified on the 937 bp *Hind*III restriction fragment. A schematic of the additional insert is shown in Fig. 14. The observation that only 72 bp of the CP4 EPSPS sequence are present on the 937 bp *Hind*III restriction fragment explains the low hybridization intensity of this band when compared to the ~5.8 kb *Hind*III restriction fragment containing the primary, functional insert when probed with a full-length CP4 EPSPS probe (Fig. 11, lanes 4 and 5). This observation also accounts for why the additional CP4 EPSPS segment was not observed using less sensitive methods used to characterize the primary insert as described.

PCR analyses were performed on DNA extracted from Resnick BC1F2 and event 40-3-2, as well as isolated cosmid clones 4B and 6A, to demonstrate that the 5' and 3' genomic flanking sequences of the 72 bp CP4 EPSPS segment were consistent in all samples. Three different PCR analyses were performed, including one PCR verifying the 5' genomic flanking sequence using Primers A and B, a second PCR verifying the 3' genomic flanking sequence using Primers A' and C, and a third PCR amplifying from the 5' genomic flanking sequence to the 3' genomic flanking sequence using Primers B and C. The positions of all primers as well as the results of all PCR analyses are shown in Fig. 15. The control reactions without template (lanes 7, 13, and 19) and A5403 non-transgenic negative control DNA (lanes 6, 12, and 18) did not generate a PCR product in any of the analyses. The Resnick BC1F2 DNA samples (lanes 2, 8, and 14), the 40-3-2 samples (lanes 3, 9, and 15), cosmid clone 4B (lanes 5, 11, and 17) and cosmid clone 6A (lanes 4, 10, and 16)

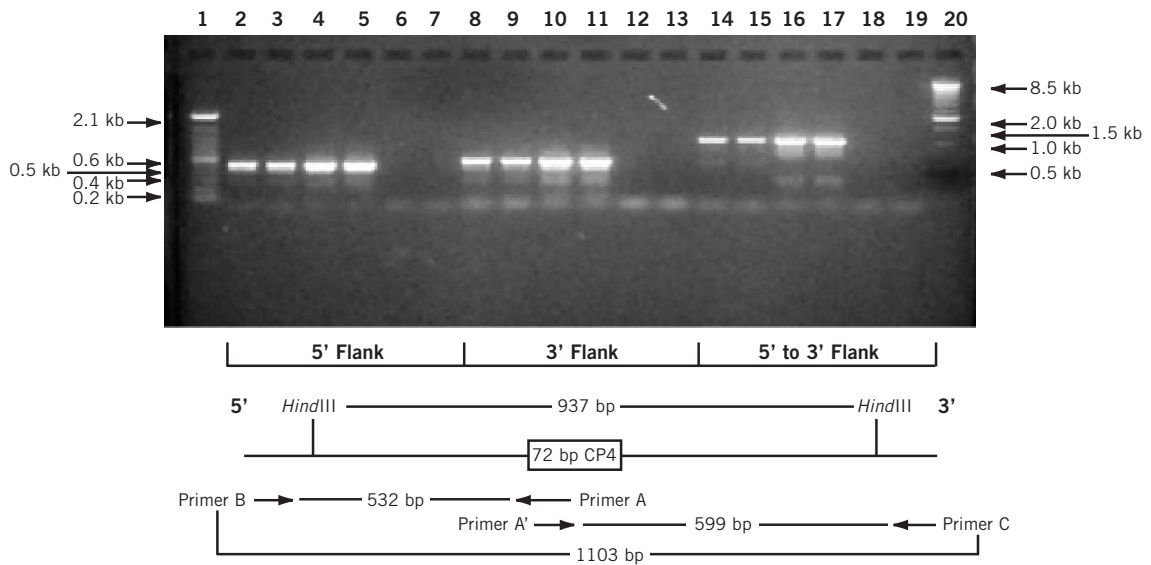


**Fig. 13. Southern blot analysis with various oligonucleotide probes of cosmid DNA prepared from the isolated cosmid clone 6A.** Oligonucleotide probes were 3'-end labelled with digoxigenin-11-dUTP and probed against individual Southern blots of DNA from the purified cosmid clone 6A digested with *Hind*III (lane 4, 4 ng per lane except for panel A where 900 pg of DNA from a pool of cosmid DNA was used). Molecular weight marker DNA was loaded in lane 1 of each panel for size estimation of the bands being observed. The same molecular weight marker was used for each panel. Plasmid PV-GMGT04 digested with the *Hind*III served as a positive control (lane 2, 1 ng per lane). Lanes 3 and 5 of each panel were blank. The positions of the oligonucleotide probes with respect to the CP4 EPSPS coding sequence are illustrated on the linear map below the panels with the probes used in panels A-D in bold print. The shaded ~200 bp region represents the maximum region delineated to be present on the ~900 bp *Hind*III fragment of DNA from 40-3-2 that was observed to hybridize with CP4 EPSPS probe-3. The arrow symbol denotes sized obtained from MW markers on ethidium bromide stained gel.



**Fig. 14. Predicted DNA inserts in soybean event 40-3-2 based on genome walking, higher sensitivity Southern blot analysis, genomic cloning, nucleotide sequencing and PCR.** There is an additional 250 bp segment of the CP4 EPSPS sequence immediately adjacent to the NOS 3' transcriptional termination element on the primary insert and an additional insert located on a 937 bp *Hind*III restriction fragment consisting of 72 bp of the CP4 EPSPS sequence. The shaded region in the CP4 EPSPS sequence in the functional primary insert represents the 72 bp present in the second insert.





**Fig 15. PCR analyses of second insert.** PCR analyses were performed using primers A and B to confirm the 5' flanking sequence, primers A' and C to confirm the 3' flanking sequence, and primers B and C to perform PCR from the 5' to 3' flank on DNA extracted from leaf tissue of Resnick BC1F2 (lanes 2, 8, and 14) and 40-3-2 material (lanes 3, 9, and 15), as well as cosmid clones 6A (lanes 4, 10, and 16) and 4B (lanes 5, 11, and 17) DNA. Lanes 1 and 20 contain Gibco BRL 100 bp DNA ladder and 500 bp DNA ladder, respectively. Lanes 6, 12, and 18 contain A5403 non-transgenic DNA PCR reactions and lanes 7, 13, and 19 were no template control PCR reactions. Ten microliters of each PCR reaction was loaded on the gel. The arrow symbol denotes sizes obtained from MW markers on ethidium bromide stained gel.

generated the expected specific size PCR products of 532 bp for the 5' flanking sequence, 599 bp for the 3' flanking sequence, and 1103 bp for the 5' to 3' flanking sequence (see diagram at bottom of Fig. 15). The PCR products from similar reactions were subjected to DNA sequencing. The results revealed that the genomic flanking sequence present in cosmid clones 4B and 6A is consistent with the genomic flanking sequence in Resnick BC1F2 material and 40-3-2 material. These results further establish the validity of the cosmid clones used in this analysis and establish that the second insert in event 40-3-2 consists of 72 bp of the CP4 EPSPS element (base pairs 855-926 of PV-GMGT04, Fig. 1) located on a 937 bp *HindIII* restriction fragment with no other sequences from plasmid PV-GMGT04 used in the transformation of the event.

### Sequence of the 5' and 3' ends of the primary insert

The PCR-based technique GenomeWalker (CLONTECH, Palo Alto, CA) was used to generate PCR products containing DNA at the 5' and 3' ends of the inserted DNA, as well as the DNA flanking the 5' and 3' ends of

the primary insert in soybean event 40-3-2. The PCR products were subjected to DNA sequencing and multiple primers designed to the flanking sequences were paired with insert specific primers located: in the E35S promoter, to validate the sequence at the 5' end of the inserted DNA and the 5' flanking genomic sequence; and in the NOS 3' transcriptional termination element, to validate the DNA sequence at the 3' end of the inserted DNA and the sequence of the 3' flanking genomic DNA. PCR products were obtained and sequenced. The resulting sequences are shown in Fig. 5.14 and Fig. 17. Figure 16 contains the 5' DNA sequence which shows that the first 354 bp of the E35S promoter are missing with the insert beginning at base pair 2347 of PV-GMGT04 (Fig. 1). This deletion removes a duplicated portion of the E35S enhancer region and is not likely to have a significant effect on the functionality of the promoter since the region necessary for transcriptional initiation remains intact (Odell *et al.* 1985). In addition to the 105 bp of E35S which were sequenced, 186 bp of the soybean genomic DNA adjacent to the 5' end of the inserted DNA is shown in Fig. 16. Figure 17 contains the 3' DNA sequence, which demonstrates that the entire NOS 3' transcriptional termination element is present

rather than the partial NOS sequence reported above. Adjacent to the inserted DNA ending at base pair 160 of PV-GMGT04 (Fig.1), a previously unobserved 250 bp portion of the CP4 EPSPS element was identified which consists of base pairs 195-444 in Fig. 17. This sequence corresponds to base pairs 1490-1739 of PV-GMGT04 in Fig. 1. Figure 17 also shows the sequence of 416 bp of flanking soybean genomic DNA. This CP4 EPSPS segment (base pairs 1490-1739 of PV-GMGT04, Fig. 1) does not contain a promoter or 3' transcriptional termination element, therefore transcription and subsequent translation of this region is highly unlikely. A northern blot was conducted which established that no mRNA is detected other than the full-length mRNA. Furthermore, in the highly unlikely event that this region would have been transcribed and translated as a fusion to the full length CP4 EPSPS protein, western blot analysis using antisera to CP4 EPSPS would have resulted in a higher molecular weight protein species being detected. No protein other than the full-length CP4 EPSPS was observed (Rogan *et al.* 1999), strongly suggesting that this DNA sequence is not transcribed or translated as a fusion protein.

## Summary

In conclusion, it was determined that GTS 40-3-2 contained two inserted DNA segments, one containing a functional CP4 EPSPS gene construct (partial E35S promoter, chloroplast transit peptide signal sequence, CP4 EPSPS encoding sequence and NOS 3' terminator), and a second smaller insert consisting of 72 bp of CP4 EPSPS sequence. Additionally, sequencing of soybean genomic DNA flanking the functional CP4 EPSPS insert confirmed a deletion in the E35S enhancer region. The region known to be critical for proper transcriptional initiation was not disturbed. Sequencing of the NOS 3' transcriptional termination element and the flanking plant DNA revealed that the NOS sequence is intact. An additional 250 bp segment of the CP4 EPSPS element adjacent to the 3' end of the NOS 3' transcriptional termination element was shown to be present. Since neither a promoter nor a 3' transcriptional termination element is evident within either of the small CP4 EPSPS segments, it is extremely unlikely that these regions would be transcribed. Furthermore, northern blot and western blot data show that only the expected CP4 EPSPS full-length transcript and protein are detected, respectively. These data support the conclusion that neither transcription nor translation of these CP4 EPSPS DNA segments occurs.

1	<u>CTGCGTGGG</u>	<u>GTCCATCTTT</u>	<u>GGGACCTCT</u>	<u>CGGCAGAGC</u>	<u>ATCTTCAAGC</u>
51	<u>ATGDCCTTC</u>	<u>CTTATGDC</u>	<u>ATGATGCCAT</u>	<u>TTCTAGGAGC</u>	<u>CACTTCCTT</u>
101	<u>TTCAATTGG</u>	<u>GTTCCCTATG</u>	<u>TTTATTTAA</u>	<u>CCCTGATGTA</u>	<u>TGATCTTATT</u>
151	<u>TTGAAATGAA</u>	<u>TGCAATAAGT</u>	<u>TTTCTTAGT</u>	<u>AAAAAAGAT</u>	<u>AAACATTGTA</u>
201	<u>TACAAACAAA</u>	<u>TTAAACCATC</u>	<u>CAAAAATAAC</u>	<u>TCATTAGCAT</u>	<u>CCCTTAAATT</u>
251	<u>CAAGCCTTTC</u>	<u>AATAAATTGC</u>	<u>ACAACTTTCT</u>	<u>GAATTCAAA</u>	<u>C</u>

Fig. 16. 5' flanking sequence of the primary insert in soybean event 40-3-2. The underlined base pairs 1-105 (corresponding to bp 2241-2347 of PV-GMGT04, Fig. 1) represent a portion of the E35S promoter. Base pairs 106-291 represent flanking soybean genomic DNA.

1	<u>TTCTTTTGA</u>	<u>ATAGCTTAG</u>	<u>CATGATATA</u>	<u>TTACATGTA</u>	<u>ATGCAATGC</u>
51	<u>TTATTATGA</u>	<u>GATGGTTTT</u>	<u>TATGATAGA</u>	<u>GTCCGCAAT</u>	<u>TATCAATTA</u>
101	<u>ATAGCATA</u>	<u>GAALACAAA</u>	<u>TATAGCCGCG</u>	<u>CAAAATAGA</u>	<u>TAAATTATG</u>
151	<u>CGCGGCTGT</u>	<u>CATCTATGT</u>	<u>ACTAGATCG</u>	<u>GGATGATCC</u>	<u>CCCAAGGCTC</u>
201	<u>TTTCATGTC</u>	<u>GGGGGCTCG</u>	<u>CGAGGGTGA</u>	<u>AAAGGCATC</u>	<u>ACGGCCCTTC</u>
251	<u>TGAAAGGCA</u>	<u>GAAGCTCAT</u>	<u>AATAGGSCA</u>	<u>AGCCATGCA</u>	<u>GGCATAGGC</u>
301	<u>CCAGGATCC</u>	<u>GTAGGAGAG</u>	<u>CGACACTCG</u>	<u>ATCATGATG</u>	<u>GGTTCGCAAT</u>
351	<u>TGGGGGCTC</u>	<u>CTGGGGCTG</u>	<u>AGGGGGGCT</u>	<u>CGATTTGGC</u>	<u>AATGGGCCA</u>
401	<u>CGGCTGCG</u>	<u>CCTGACCATG</u>	<u>GGCTTGGTG</u>	<u>GGCTTACGA</u>	<u>TTTCAGGCTC</u>
451	<u>ATCATGCTCG</u>	<u>GAATTTTAG</u>	<u>CGAGATTATA</u>	<u>AGTATCTTC</u>	<u>TGGGAGCTC</u>
501	<u>TGCTGTACT</u>	<u>GTTGAAATG</u>	<u>GAGCAGAGT</u>	<u>CTTCTGAGT</u>	<u>CATAGGATA</u>
551	<u>AATAAATAT</u>	<u>AATAGTAAA</u>	<u>TTTTTAATT</u>	<u>AAATAAATCA</u>	<u>ATTACTTCAT</u>
601	<u>AAATAATTT</u>	<u>TTTTATAGA</u>	<u>TATGTTACA</u>	<u>TTCTAGCTG</u>	<u>ATATAGACT</u>
651	<u>AAATATAAG</u>	<u>AGCTTAAA</u>	<u>ATTTTGTG</u>	<u>GAAGAAATG</u>	<u>TTATTAAAG</u>
701	<u>ACAAATCAA</u>	<u>TTAGTTTAT</u>	<u>CAGGCTCAT</u>	<u>TTTGAAGT</u>	<u>AGGAACTTC</u>
751	<u>CAGCAATTT</u>	<u>AATATAGAT</u>	<u>AACTGCTCT</u>	<u>CCCAAGATG</u>	<u>TGGAGTTTC</u>
801	<u>TCCTCTGCT</u>	<u>ATTACATGA</u>	<u>AAAAAATAA</u>	<u>AAATAAATA</u>	<u>AGATAAGAT</u>
851	<u>TAACTTCAA</u>				

Fig. 17. 3' flanking sequence of the primary insert in soybean event 40-3-2. The underlined base pairs 1-194 (corresponding to base pairs 160-353 of PV-GMGT04, Fig. 4.1) represent the 3' portion of the NOS 3' transcriptional termination element present within the functional insert, along with 16 base pairs of plasmid PV-GMGT04 (italics) immediately adjacent to NOS. The boxed region at base pairs 195-444 (corresponding to base pairs 1490-1739 of PV-GMGT04, Fig. 1) delineates 250 bp of the CP4 EPSPS coding region. Base pairs 445-860 represent flanking soybean genomic DNA with a *Hind*III site indicated in bold letters beginning at base pair 852.

## References

- Dellaporta, S.L., Wood, J. & Hicks, J.B. (1983). A plant DNA miniprep: Version II. *Plant Mol. Biol. Reporter* **1**, 19-21.
- Kolacz, K.H. & Padgett, S.R. (1994). Molecular characterization of the 5' and 3' ends of the inserted DNA and the stability of the insert in glyphosate-tolerant soybean line 40-3-2. Monsanto Study #93-01-30-43, Monsanto Technical Report MSL-13524, St. Louis, MO.

- McPherson *et al.* eds. (1991). PCR: A Practical Approach. Oxford University Press, Oxford, pp. 1-13.
- Mullis, K & Faloona, F. (1987). Specific synthesis of DNA in vitro via a polymerase-catalyzed chain reaction. *Methods in Enzymology* **155**, 335-350.
- Odell, J.T., Nagy, F. & Chua, N.H. (1985). Identification of DNA sequences required for activity of the cauliflower mosaic virus 35S promoter. *Nature* **313**, 810-812.
- Padgett, S.R., Taylor, N.B., Nida, D.L., Bailey, M.R., MacDonald, J., Holden, L.R. & Fuchs, R.L. (1996). The composition of glyphosate-tolerant soybean seeds is equivalent to that of conventional soybeans. *Journal of Nutrition* **126**, 702-716.
- Re, D.B., Padgett, S.R., Delannay, X., Kolacz, K.H., Nida, D.L., Peschke, V.M., Derting, C.W., Rogers, S.G., Edwards, J.W., Barry, G.F. & Biest, N.A. (1993). Petition of determination of nonregulated status: soybeans with a Roundup Ready gene. Submitted to USDA, St. Louis.
- Rogan, G.J., Dudin, Y.A., Lee, T.C., Magin, K.M., Astwood, J.D., Bhakta, N.S., Leach, J.N., Sanders, P.R. & Fuchs, R.L. (1999). Immunodiagnostic methods for detection of 5-enolpyruvylshikimate-3-phosphate synthase in Roundup Ready soybeans. *Food Control* **10**, 407-414.
- Southern, E.M. (1975). Detection of specific sequences among DNA fragments separated by gel electrophoresis. *J. Molecular Biology* **98**, 503-517.

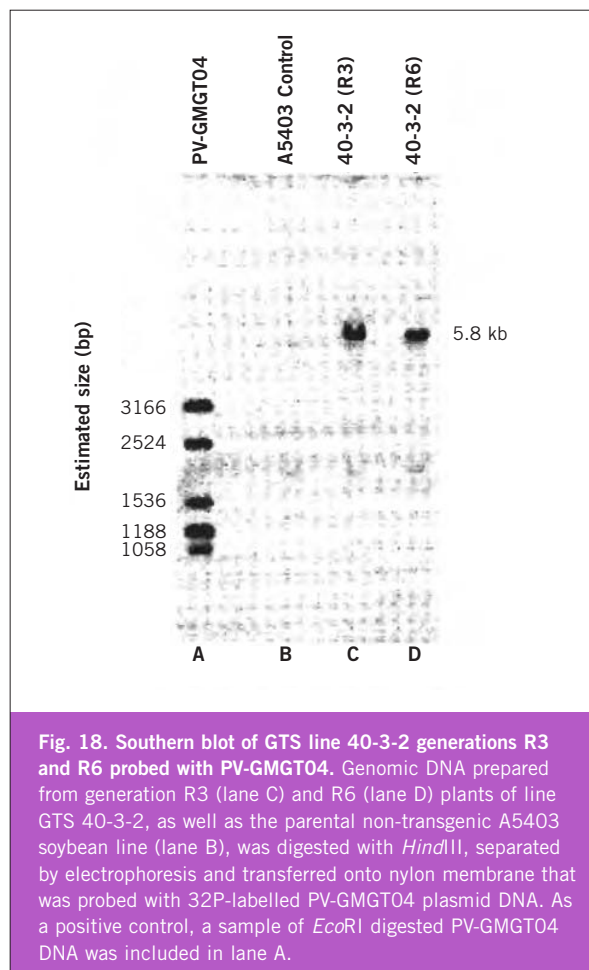
## Genetic stability of the introduced trait

The stable integration of the CP4 EPSPS gene into the genome of GTS 40-3-2 was demonstrated through a combination of molecular (*e.g.*, Southern blotting, PCR analysis, and protein expression) and phenotypic trait segregation analyses.

## Southern blot analyses

### Methods

Total genomic DNA was isolated from leaf tissue obtained from R3 and R6 generation plants of GTS 40-3-2 according to Dellaporta *et al.* (1983) with minor modifications. One or two leaflets from the first trifoliate leaf of greenhouse-grown plants was used as source material and an RNase incubation step followed by a phenol/chloroform extraction was added before the final ethanol precipitation. Genomic DNA was quantitated

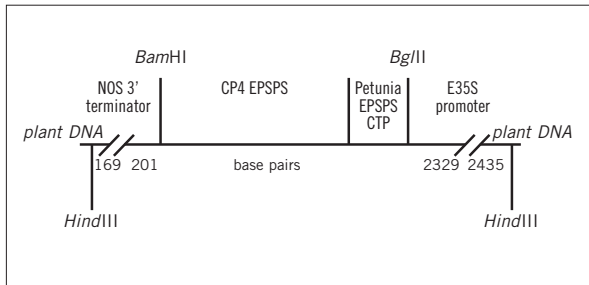


**Fig. 18. Southern blot of GTS line 40-3-2 generations R3 and R6 probed with PV-GMGT04.** Genomic DNA prepared from generation R3 (lane C) and R6 (lane D) plants of line GTS 40-3-2, as well as the parental non-transgenic A5403 soybean line (lane B), was digested with *Hind*III, separated by electrophoresis and transferred onto nylon membrane that was probed with <sup>32</sup>P-labelled PV-GMGT04 plasmid DNA. As a positive control, a sample of *Eco*RI digested PV-GMGT04 DNA was included in lane A.

spectrophotometrically and digested with *Hind*III. Digested samples from each plant (5 µg DNA), as well as *Hind*III digested DNA from the parental A5403 line, and *Eco*RI digested PV-GMGT04 plasmid DNA (100 µg) as a positive control, were separated by 0.8% agarose-TAE gel electrophoresis. Separated fragments were transferred onto nylon membrane and probed with <sup>32</sup>P-labelled PV-GMGT01 plasmid DNA and subjected to autoradiography (Southern 1975; Sambrook *et al.* 1989).

## Results and discussion

Previous analyses using polymerase chain reaction (PCR) amplification with specific 5' and 3' terminal primers had verified the boundary regions of the inserted DNA and demonstrated that neither *Hind*III site originally present in plasmid PV-GMGT04 (at positions 155 and 2707) was incorporated into the host genome. Southern blot analysis of *Hind*III digested genomic DNA from the original transformant had demonstrated the presence of a 5.8 Kb fragment, indicating that the two *Hind*III sites bordering this fragment must be located in the plant genome, on either side of the inserted DNA



**Fig. 19.** Diagrammatic representation of the insert contained in GTS 40-3-2 showing *HindIII* digestion sites. Based on PCR analysis of the 5' and 3' terminal regions of the inserted DNA fragment, neither *HindIII* site present at positions 155 and 2707 of plasmid PV-GMGT04 were incorporated into the host plant genome. The two *HindIII* sites bordering the 5.8 Kb fragment (Fig. 18) are located in the plant genome.

(Fig. 19). As it contains both inserted and border DNA, this fragment was considered an appropriate sentinel for monitoring the inserted DNA's stability in GTS 40-3-2.

When *HindIII* digested genomic DNA from generation R3 and R6 GTS 40-3-2 plants was probed with 32P-labelled PV-GMGT04, a single 5.8 Kb fragment was detected (Fig. 18). The fact that this same size fragment is present in both generations of 40-3-2 indicates that the plasmid DNA insert and the plant border DNA are stably maintained throughout the plant life cycle over four generations. Similar, more sensitive Southern blot analyses were also able to demonstrate the co-segregation of a second inserted DNA fragment containing a 72 bp sequence corresponding to a region from the CP4 EPSPS encoding gene. These data indicated that the primary insert and this second, smaller insert behaved as a single genetic locus.

### Inheritance

Confirmation that the glyphosate tolerance trait present in GTS 40-3-2 segregates according to a defined pattern (Mendelian segregation) was obtained from the analysis of F<sub>2</sub> progenies of backcrosses between GTS 40-3-2 and other, non-transgenic, soybean lines.

Table 3 summarizes the segregation patterns of progeny of crosses between 40-3-2 and 17 non-transgenic cultivars. A consistent 3 tolerant to 1 sensitive ratio was observed among all F<sub>2</sub> progeny, indicating that the glyphosate tolerance in 40-3-2 is conditioned by a single dominant gene.

### Conclusion

The information summarized in this section supports the conclusion that GTS 40-3-2 containing the gene

**Table 3.** Segregation of glyphosate tolerance in F<sub>2</sub> progeny of crosses between GTS 40-3-2 and 17 non-transgenic cultivars

Family	Tolerant	Sensitive	Chi <sup>2</sup>
1	17	4	0.40
2	10	2	0.44
3	12	4	0.00
4	16	4	0.27
5	16	5	0.02
6	14	3	0.49
7	18	5	0.13
8	10	4	0.10
9	17	7	0.22
10	6	3	0.33
11	15	4	0.16
12	17	1	3.63
13	10	1	1.48
14	16	5	0.02
15	3	1	0.00
16	18	3	1.29
17	19	5	0.22
Total	234	61	2.94

Uncorrected chi-square goodness-of-fit test for hypothesis of 3:1 segregation. None of the chi-square values are significant at the 95% confidence level ( $chi^2_{0.05}=3.84$ ).

encoding CP4 EPSPS is genetically stable, and that any conclusions regarding the safety of GTS 40-3-2 are also valid for its progeny and other soybean varieties derived from it through classical breeding techniques.

### References

- Dellaporta, S.L., Wood, J. & Hicks, J.B. (1983). A plant DNA miniprep: Version II. *Plant Mol. Biol. Reporter* **1**, 19-21.
- Sambrook, J., Fritsch, E.F. & Maniatis, T. (1989). *Molecular cloning: A laboratory manual*. Cold Spring Harbor Laboratory Press, Cold Spring Harbor, New York.
- Southern, E.M. (1975). Detection of specific sequences among DNA fragments separated by gel electrophoresis. *J. Molecular Biology* **98**, 503-517.

### Expressed material / effect

#### Materials and methods

#### Field trials

In order to generate plant material for expression and quality analysis, field trials were conducted at one site in

Puerto Rico in 1992, in nine sites across the United States during 1992, and at an additional four sites in the United States in 1993. Plots were arranged in randomized complete block designs and consisted of four genotypes: the parental control line A5403, GTS 40-3-2, as well as two additional GTS lines. Samples of leaf tissue and seeds collected from each trial site were used as test materials for determining the expressed levels of CP4 EPSPS by quantitative enzyme linked immunosorbent assay (ELISA).

### ELISA assays

Seed and leaf tissue samples from GTS 40-3-2 and control A5403 plants were prepared for ELISA by grinding to a fine powder in liquid nitrogen and resuspending a weighed volume in extraction buffer (100 mM Tris-HCl pH 7.8, 100 mM sodium borate, 5 mM MgCl<sub>2</sub>, 0.05% v/v Tween 20, and 0.2% sodium ascorbate) at a 1:100 tissue to buffer ratio (30 mg tissue / 3 ml buffer). The suspension was homogenized (30 sec; PT3000 Polytron), centrifuged to remove cell debris, and the supernatant either assayed immediately or stored frozen at minus 80°C. For the CP4 EPSPS ELISA, the double antibody sandwich (primary antibody from goat and secondary antibody from rabbit) was detected with donkey anti-rabbit alkaline phosphatase conjugate followed by development with p-nitrophenyl phosphate (p-NPP). The GUS direct double antibody sandwich ELISA utilized a commercially available rabbit anti-GUS antibody (CLONTECH Laboratories) and its alkaline phosphatase conjugate, with p-NPP development. Quantitation of CP4 EPSPS or GUS in plant samples was accomplished by extrapolation from the logistic curve-fits of the purified mature CP4 EPSPS (*i.e.*, without transit peptide) or GUS standard curves (both standards purified from *E. coli* overexpression strains).

### Western immunoblot analysis

Samples of soybean tissue and processed soybean fractions were ground to a powder in liquid nitrogen using a mortar and pestle, and resuspended in extraction buffer (100 mM Tris-HCl pH 7.5, 1 mM benzamidine-HCl, 5 mM DTT, 2.5 mM EDTA, 1.0 mM PMSF, 10 mM CHAPS, and 6M guanidine-HCl) at a 1:50 tissue to volume buffer ratio. Samples were homogenized with a Omni-2000 hand held homogenizer (setting 4-5; 30 sec), centrifuged to remove cell debris, and the supernatant saved for subsequent analysis. Proteins were separated by SDS-PAGE on pre-cast 4-20% linear polyacrylamide gradient gels using the buffer system of Laemmli (1970). Separated proteins were then electrophoretically

transferred onto PVDF membrane, treated with Tris buffered saline containing 5% non-fat dried milk powder and 0.2% Tween-20 to block non-specific protein binding sites. CP4 EPSPS protein bound to the membrane was probed using a 1:1000 dilution of goat anti-CP4 EPSPS IgG (1-2 hr at room temperature), and bound antibody was detected by incubating sequentially with biotin-labelled Protein G and horseradish peroxidase-conjugated NeutrAvidin, followed by enhanced chemiluminescence development.

### CP4 EPSPS and GUS enzymatic assays

The procedure used to determine the amount of functionally active CP4 EPSPS was based on measuring the incorporation of <sup>14</sup>C into EPSPS from <sup>14</sup>C-phosphoenol pyruvate (PEP) using high pressure liquid chromatography (HPLC) separation and a radioactivity detector (Padgette *et al.* 1988; Padgette *et al.* 1987). Reactions were incubated at 25°C in buffer containing 50 mM HEPES pH 7.0, 0.1 mM ammonium molybdate, 5 mM KF, 1 mM <sup>14</sup>C-PEP, and 2 mM shikimate-3-phosphate. For analysis, samples were quenched with 100 mM Tris-HCl pH 7.8, 100 mM sodium borate, 5 mM MgCl<sub>2</sub>, 0.2% sodium ascorbate, desalted using a disposable spin-column, and separated via HPLC. One unit (U) of enzyme activity was defined as 1 micromole EPSPS produced / minute at 25°C.

The enzymatic assay for GUS was a modification of the method of Jefferson *et al.* (1986), and was based on the GUS-catalyzed formation of p-nitrophenol from p-nitrophenol-beta-D-glucuronide. Reaction mixtures (8 mM p-nitrophenyl-beta-D-glucuronide, 49 mM sodium phosphate, 10 mM 2-mercaptoethanol, 10 mM EDTA, 0.1% sarkosyl, and 0.1% Triton X-100, pH 7.4) were incubated for 1 – 5 min, quenched by the addition of 2.5 M 2-amino-2-methyl-1,3-propanediol, and the production of p-nitrophenol determined spectrophotometrically by measuring the absorbance at 406 nm. One unit (U) of enzyme activity was defined as 1 micromole p-nitrophenol produced / min at 37°C.

## Results and discussion

Expression tests for CP4 EPSPS and GUS were performed by ELISA, and, as illustrated in Table 4, only CP4 EPSPS was detectable in either seed or leaf tissue. The mean expression levels of CP4 EPSPS were 0.288 µg/mg tissue (fresh weight) or 0.443 µg/mg tissue, respectively, for seed or leaf tissue collected from field trials during 1992. Similar, but somewhat lower levels of

**Table 4. ELISA analysis of CP4 EPSPS and GUS in GTS line 40-3-2**

Sample <sup>1</sup>	No. of sites	Ug protein / mg tissue fresh weight	
		Mean	Range <sup>2</sup>
<b>CP4 EPSPS<sup>3</sup></b>			
Leaf <sup>4</sup> 1992	8	0.443	0.251-0.789
Leaf <sup>4</sup> 1993	3	0.415	0.299-0.601
Seed 1992	9	0.288	0.186-0.395
Seed 1993	4	0.201	0.127-0.277
<b>GUS<sup>3</sup></b>			
Leaf <sup>4</sup> 1992	8	ND#	–
Seed 1992	9	ND#	–

<sup>1</sup> All samples were frozen immediately and shipped and stored frozen. Means reported are of the site means. Soybean plant samples for ELISA were generated from nine locations in 1992 and four locations in 1993

<sup>2</sup> Range denotes the lowest and highest individual assay for each plot.

<sup>3</sup> No CP4 EPSPS or GUS proteins were detected in the A5403 parental control line samples (grown at identical locations) in either leaf or seed samples.

<sup>4</sup> The center leaflet from the fully expanded third trifoliolate of six plants randomly selected from different rows in various locations in each treatment plot were collected and pooled by plot.

#ND. Not detected.

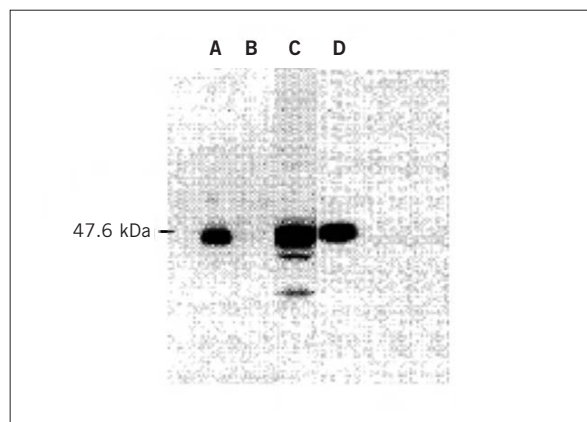
expression, were measured for tissue samples collected from four field trials during 1993 (Table 4).

The ELISA results were supported by enzymatic activity assays performed on seed pools of line GTS 40-3-2 collected from the 1992 field tests. The measured glyphosate-tolerant EPSPS activity was 0.025 U/mg but no GUS enzymatic activity was detected. Neither EPSPS nor GUS enzymatic activity was detectable in seed extracts from the non-transgenic parental A5403 soybean line. The lack of detectable GUS protein or enzyme activity confirm Southern blot analyses demonstrating that GUS encoding sequences were not incorporated into the GTS 40-3-2 genome.

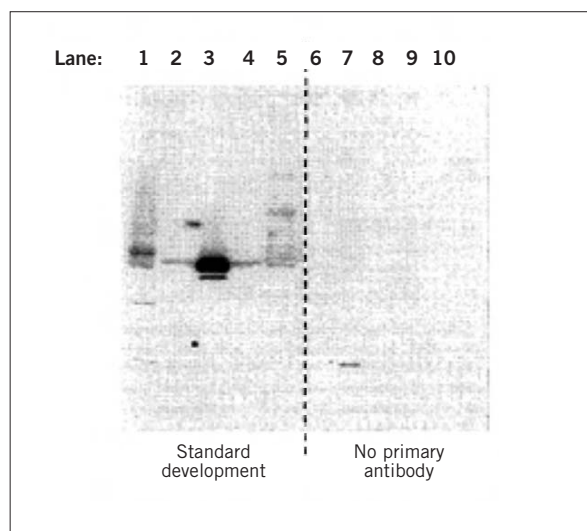
Western blot analysis showed that the 47 kDa CP4 EPSPS protein and no additional CP4 EPSPS immunoreactive proteins are detected in event GTS 40-3-2 (Fig. 20). The anti-CP4 EPSPS antisera used for Western blot detection showed almost no cross-reactivity with similar EPSPS proteins derived from different plant sources (Fig. 21).

## References

Jefferson, R.A., Burgess, S.M. & Hirsch, D. (1986). Beta-glucuronidase from *Escherichia coli* as a gene-fusion marker. *Proc. Natl. Acad. Sci. USA* **83**, 8447-8451.



**Fig. 20. Western immunoblot detection of CP4 EPSPS protein in samples of GTS 40-3-2 soybean seed (lane C) or toasted meal prepared from GTS 40-3-2 soybean seed (lane D). Purified CP4 EPSPS from an *E. coli* overexpression culture was included as a positive control (lane A), and a negative buffer control sample is shown in lane B.**



**Fig. 21. Specificity of the CP4 EPSPS Western blot analytical method. All EPSPS proteins were expressed in *E. coli* and purified to near homogeneity, and the maize and petunia EPSPS proteins were loaded at 10 times the level of CP4 EPSPS. Samples tested were petunia EPSPS (50 ng; lanes 2, 8), CP4 EPSPS (5 ng; lanes 3, 9), and maize EPSPS (50 ng; lanes 4, 10). Molecular weight markers included the Promega midrange markers (lanes 1, 7) and high range colour markers (lanes 5,6; Amersham). Separated proteins were electroblotted onto PVDF membrane and either processed normally (Standard Development) or left untreated with primary antibody and otherwise processed according the standard procedure (No primary antibody).**

Laemmli, U.K. (1970). Cleavage of structural proteins during the assembly of the head of bacteriophage. *Nature* **227**, 680-685.

Padgett, S.R., Huynk, Q.K., Aykent, S., Sammons, R.D., Sikorski, J.A. & Kishore, G.M. (1988).

Identification of the reactive cysteines of *Escherichia coli* 5-enolpyruvylshikimate-3-phosphate synthase and their nonessentiality for enzymatic catalysis. *J. Biological Chemistry* **263**, 1798-1802.

Padgett, S.R., Huynh, Q.K., Borgmeyer, J., Shah, D.M., Brand, L.A., Re, D., Bishop, B.F., Rogers, S.G., Fraley, R.T. & Kishore, G.M. (1987). Bacterial expression and isolation of *Petunia hybrida* 5-enolpyruvylshikimate-3-phosphate synthase. *Arch. Biochem. Biophys.* **258**, 564-573.

## Assessment of possible toxicity

Due to the relatively low level of expression of CP4 EPSPS protein in GTS 40-3-2, purified CP4 EPSPS from bacterial cultures was used as test material for the acute mouse gavage and protein digestibility studies described below. This is a common practice when assessing the potential toxicity of introduced novel proteins and requires that physiochemical and functional equivalence be established between bacterial and plant expressed forms of the protein. In the case of *E. coli* expressed CP4 EPSPS (lacking the chloroplast transit peptide), functional equivalence with the plant expressed protein was based on the criteria of molecular weight, immunological cross-reactivity, absence of glycosylation, N-terminal amino acid sequence, and enzymatic activity (Table 6).

## Acute mouse gavage study with CP4 EPSPS protein

### Methods

An acute mouse gavage study using *E. coli* produced mature CP4 EPSPS protein (lacking the chloroplast transit peptide) was performed to directly assess the

potential toxicity associated with the CP4 EPSPS protein (Naylor 1993). CP4 EPSPS protein was administered by oral gavage at dosages up to 572 mg/kg of body weight. Mice were observed twice daily for signs of toxicity and food consumption was recorded daily. Food and water were provided ad libitum. All animals were sacrificed on post-dosing day 8 and 9 and subjected to gross necropsy. Approximately 40 tissues were collected and saved from each animal in the test.

## Results and discussion

The results from this study demonstrated that there were no adverse effects on mice administered the CP4 EPSPS protein by oral gavage at dosages up to 572 mg/kg. The dose represented an approximate 1300-fold safety margin relative to the highest potential human consumption of plant-expressed CP4 EPSPS, assuming no loss of protein due to processing. There were no statistically significant differences in body weight, cumulative body weight, or food consumption between the vehicle or bovine serum albumin protein control groups and CP4 EPSPS protein-treated groups.

## Digestion of CP4 EPSPS in simulated gastric and intestinal fluids

### Methods

Simulated mammalian gastric and intestinal digestive fluids were used in *in vitro* assays to assess the susceptibility of *E. coli* expressed CP4 EPSPS to proteolytic degradation. Simulated gastric and intestinal fluids were prepared as described in the United States Pharmacopeia (US Pharmacopeia 1990), a frequently cited reference for *in vitro* digestion studies. *In vitro*

**Table 6. Summary of equivalence analyses: GTS vs. *E. coli* CP4 EPSPS proteins**

Analytical Method	Criteria	Results
SDS-PAGE	Similar electrophoretic mobility.	Similar apparent MW.
Western immunoblot	Similar electrophoretic mobility and immunological response.	Similar apparent MW and immunological response.
Glycosylation	Comparable response with glycosylation detection.	No CP4 EPSPS specific carbohydrate moieties detected.
Amino Acid Sequence	Corresponds through 10 amino acid positions.	Correct N-terminus through 15 positions (N-terminal methionine present on <i>E. coli</i> produced CP4 EPSPS).
CP4 EPSPS Enzymatic Activity	Specific activities (SA) will not differ more than a factor of 2.	GTS 3.9 U/mg <i>E. coli</i> 3.0 U/mg.
ELISA	Comparable dose response.	Dose response curves comparable.

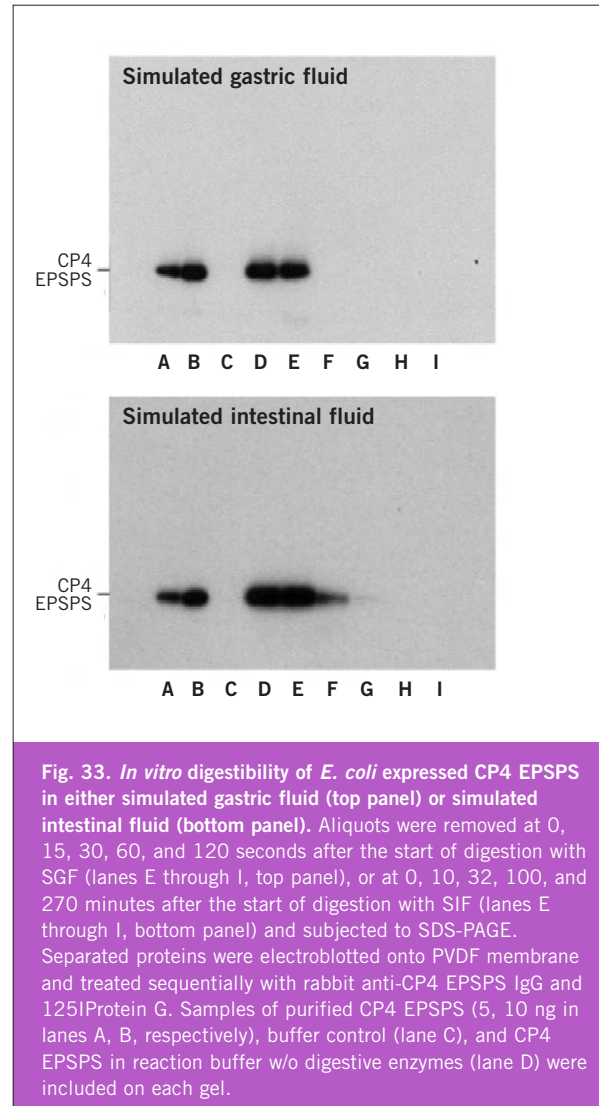
digestive fate of CP4 EPSPS was monitored using Western immunoblot analysis and by measuring enzymatic activity of aliquots removed at various times following the start of digestion.

## Results and discussion

CP4 EPSPS was rapidly degraded in both simulated gastric fluid (SGF) and simulated intestinal fluid (SIF) with a half-life of less than 15 seconds or less than 10 minutes, respectively. To put the rapid *in vitro* degradation of the CP4 EPSPS protein into perspective, solid food has been estimated to empty from the human stomach by about 50% in two hours, while liquid empties 50% in approximately 25 minutes (Sleisenger & Fordtran 1989). If some of the CP4 EPSPS protein did survive the gastric system, it would be rapidly degraded by intestinal proteases. The transit time through the intestine (for <sup>51</sup>Cr-labelled chromate, which is not absorbed) has been estimated to be 4-10 hours for the first products to appear in the feces and 68-165 hours for the last to be detected. Thus the  $T_{50}$  of 10 minutes for the *in vitro* degradation of CP4 EPSPS provides a wide margin of assurance that virtually all of the protein would be degraded during its initial transit through the intestinal tract.

### Lack of homology of CP4 EPSPS protein with other protein toxins

The deduced (predicted) amino acid sequence of the CP4 EPSPS was compared with the sequences of 1935 known protein toxins present in the Pir protein, Swissprot, and Genpept protein databases. The analysis of homology of CP4 EPSPS protein to known protein toxins was based on the fact that patterns of amino acid sequence or regions of strong homology shared between two or more proteins may provide insight into the biological activity of the protein. Homologous proteins derived from a common ancestor have similar amino acid sequences, are structurally similar and often share common function. Homology was determined by comparing the degree of amino acid sequence similarity between proteins using published criteria (Doolittle 1990). There were no detected homologies with known toxins. The lack of significance between the alignments was assessed by randomizing the CP4 EPSPS amino acid sequence, keeping relative proportions of individual amino acids the same, and comparing the randomized sequence with the identical database of known protein



toxins. The output comparisons generated in this manner closely resembled the results obtained with the unrandomized CP4 EPSPS sequence.

## Conclusion

In summary, the CP4 EPSPS protein shows no amino acid sequence similarity to known protein toxins, is rapidly degraded *in vitro* under conditions simulating the digestive conditions in the mammalian stomach or intestinal tract, and displays no indications of acute toxicity as measured by treatment-related adverse effects in mice administered CP4 EPSPS protein by oral gavage.

## References

Doerfler, W. & Schubbert, R. (1997). Fremde DNA im Saugersystem. *Deutsches Arzteblatt* **94**, 51-52.



- Doolittle, R.F. (1990). Searching through sequence databases. *In: Molecular Evolution: Computer Analysis of Protein and Nucleic Acid Sequences*. Doolittle, R.F. (ed.). Pp. 99-110. Academic Press, San Diego, CA.
- Naylor, M. (1993). Acute oral toxicity study of CP4 EPSPS in albino mice. Monsanto Report ML92542, St. Louis, MO.
- OECD (2000). Report of the task force for the safety of novel foods and feeds. C(2000)86/ADD1 Organization for Economic Cooperation and Development, Paris.
- Sleisenger, M.H. & Fordtran, J.S. (1989). *Gastrointestinal Disease. Volume 1, Pathophysiology Diagnosis Management*. 4th Edition. W.B. Saunders Co., Toronto. pp 685-689.
- US Pharmacopeia (1990). Vol. XXI, NF XVII. United States Pharmacopeial Convention, Inc., Rockville, MD. 1788 pp.

### Assessment of possible allergenicity

The potential allergenicity of the CP4 EPSPS protein expressed in transgenic GTS 40-3-2 soybeans was assessed by examining: (1) the immunoreactivity of separated soybean proteins with IgE antibodies from sera obtained from soybean allergic individuals; (2) the physiochemical properties of CP4 EPSPS in relation to known allergenic proteins; (3) the lability of CP4 EPSPS in simulated gastric and intestinal fluids; (4) amino acid sequence similarities with other naturally occurring plant derived EPSPS enzymes and with known protein allergens; and (5) estimated dietary exposure to CP4 EPSPS based on its concentration in food.

### Immunoreactivity with sera from sensitized individuals

Protein extracts were prepared from non-toasted, defatted soy flour derived from GTS 40-3-2, the parental A5403 line, and three commercially available soy flour preparations, and separated by sodium dodecyl sulfate (SDS) polyacrylamide gel electrophoresis (PAGE). Separated proteins were electroblotted onto PVDF membranes and probed with IgE antibodies from pooled serum obtained from several individuals shown to be sensitive to soybean products by direct food challenges (Burks *et al.* 1988). As controls, IgE antibodies from normal and peanut-sensitive individuals

were used to test the specificity of similar antibodies from soybean-sensitive individuals.

Both the presence and the relative levels of the endogenous allergenic proteins in all of these soybean preparations were comparable, demonstrating that the profile of allergenic proteins was not significantly altered during the production of GTS 40-3-2.

### Physiochemical properties of CP4 EPSPS

Although the molecular mass of CP4 EPSPS, 47.6 kDa, is within the size range of 10-70 kDa reported for many allergenic proteins, its other physiochemical properties are not consistent with the characteristics of most allergenic proteins. CP4 EPSPS is not heat stable and all detectable enzymatic activity and tertiary structure are lost (established by loss of ELISA reactivity) after the toasting step during processing (Padgett *et al.* 1993). This instability of CP4 EPSPS during processing was expected based on the rapid loss of activity observed with the purified protein upon heat treatment (65°C, 15 minutes).

As most protein allergens are glycosylated, the plant-expressed CP4 EPSPS protein was examined for the presence of carbohydrate moieties, and found not to be glycosylated (Harrison *et al.* 1993). This result was expected since protein glycosylation requires passage through the rough endoplasmic reticulum and Golgi bodies, which requires specific targeting sequences on the N-terminus of the protein that were not engineered into the CP4 EPSPS construct. The CP4 EPSPS gene product was targeted to the chloroplast, the site of aromatic amino acid biosynthesis, and this targeting does not require or enable glycosylation.

### Stability to *in vitro* digestion

The ability of food allergens to reach and to cross the mucosal membrane of the intestine, and thus enter the circulatory system, is a likely prerequisite to allergenicity. A protein that is stable to the acid-protease and proteolytic conditions of the stomach and intestine, respectively, has an increased probability of reaching the intestinal mucosa. Many allergenic proteins exhibit proteolytic stability (King *et al.* 1967; Kortekangas-Savolainen *et al.* 1993; Onaderra *et al.* 1994; Taylor 1992; Taylor *et al.* 1987; Metcalfe 1985), although the majority remain untested.

As has already been discussed in Chapter 9 (Toxicity), the CP4 EPSPS protein was extremely

susceptible to degradation (Ream *et al.* 1993) in both simulated gastric fluids (*e.g.*, pepsin digestion; T50 < 15 seconds) and simulated intestinal fluids (*e.g.*, trypsin digestion; T50 < 10 minutes). This lability to digestion by proteases present in the mammalian digestive tract is not a feature of most protein allergens, and provides additional evidence supporting the lack of allergenic potential for CP4 EPSPS.

## Amino acid sequence analysis

The predicted amino acid sequence of the CP4 EPSPS protein was compared with the amino acid sequences of 121 known allergenic proteins contained in three protein databases (Genpept, Pir protein, and Swissprot) using the FASTA computer program (Pearson & Lipman 1988). No biologically significant homology (Doolittle 1990) and, based on an epitope size of 8 contiguous amino acids, no immunologically significant sequence similarities were observed with allergens.

## Prevalence in food

A significant factor contributing to the allergenic potential of food proteins is their concentration in foods. Most allergens are present as major protein components in the specific food, in amounts ranging from 1-80% of the total protein (Fuchs & Astwood 1996). This is true for the allergens in milk (Taylor *et al.* 1987), soybean (Burks *et al.* 1988), and peanuts (Barnett *et al.* 1983). In contrast, the CP4 EPSPS is present in very low levels in soybean seed (0.03% fresh weight, or 0.08% of the total protein).

## Conclusion

In summary, the data and analyses described above and summarized in Table 7 support the conclusion

**Table 7. Characteristics of known protein allergens<sup>1</sup>**

Characteristic	Allergens	CP4 EPSPS
Allergenic source of gene	yes	no
Mol wt 10-70 kDa	yes	yes
Glycosylated	yes <sup>2</sup>	no
Similar sequence to allergens	yes	no
Stable to digestion	yes	no
Stable to processing	yes	no
Prevalent protein in food	yes	no

1. As described in Taylor (1992) and Taylor *et al.* (1987).

2. Typically, but not absolutely.

that the CP4 EPSPS protein is not derived from an allergenic source, does not possess immunologically relevant sequence similarity with known allergens, and does not possess the characteristics of known protein allergens. This information, coupled with the extremely rapid digestion of this protein under *in vitro* digestive conditions that mimic human digestion, established that there is no reason to believe that plant expressed CP4 EPSPS protein should pose any significant allergenic risk for consumption of the products generated from GTS 40-3-2 soybeans.

## References

- Anderson, J.A. (1996). Allergic reactions to foods. *Critical Reviews in Food Science and Nutrition* **36**, S19-S38.
- Barnett, D., Baldo, B.A. & Howden, M.E.H. (1983). Multiplicity of allergens in peanuts. *J. Allergy Clin. Immunol.* **72**, 61-68.
- Bock, S. A. (1987). Prospective appraisal of complaints of adverse reactions to foods in children during the first three years of life. *Paediatrics* **79**, 683-688.
- Burks, A.W., Brooks, J.R. & Sampson, H.A. (1988). Allergenicity of major component proteins of soybean determined by enzyme-linked immunosorbent assay (ELISA) and immunoblotting in children with atopic dermatitis and positive soy challenges. *J. Allergy Clin. Immunol.* **81**, 1135-1142.
- Burks, A.W. & Sampson, H. (1993). Food allergies in children. *Current Problems in Paediatrics* **23**, 230-252.
- Doolittle, R.F. (1990). Searching through sequence databases. *Methods in Enzymology* **183**, 99-110.
- Fuchs, R.L. & Astwood, J.D. (1996). Allergenicity assessment of foods derived from genetically modified plants. *Food Technology* **50**, 83-88.
- Harrison, L.A., Bailey, M.R., Leimgruber, R.M., Smith, C.E., Nida, D.L., Taylor, M.L. & Padgett, S.R. (1993). Equivalence of plant- and microbially-expressed proteins: CP4 EPSPS from glyphosate-tolerant soybeans and *E. coli*. Monsanto Study 92-01-30-11, Monsanto Technical Report MSL-12899, St. Louis, MO.
- Hefle, S.L., Nordlee, J. A. & Taylor, S. L. (1996): Allergenic foods. *Critical Reviews in Food Science and Nutrition* **36**, S69-S89.

- King, T.P., Norman, P.S. & Connell, J.J. (1967). Isolation and characterization of allergens from ragweed pollen, IV. *Biochemistry* **6**, 1992-2000.
- Kortekangas-Savolainen, O., Savolainen, J. & Einarsson, R. (1993). Gastrointestinal stability of baker's yeast allergens: an *in vitro* study. *Clin. Exp. Allergy* **23**, 587-590.
- Mekori, Y. A. (1996). Introduction to allergic disease. *Critical Reviews in Food Science and Nutrition* **36**, S1-S18.
- Metcalfe, D.D. (1985). Food allergens. *Clin. Rev. Allergy* **3**, 331-349.
- Metcalfe, D.D., Astwood, J. D., Townsend, R., Sampson, H. A., Taylor, S. L. & Fuchs, R. L. (1996). Assessment of the allergenic potential of foods derived from genetically engineered crop plants. *Critical Reviews in Food Science and Nutrition* **36**, S165-S186.
- Onaderra, M., Monsalve, R.I., Mancheno, J.M., Villalba, M., Martinez Del Pozo, A., Gavilanes, G. & Rodriguez, R. (1994). Food mustard allergen interaction with phospholipid vesicles. *Eur. J. of Biochem.* **225**, 609-615.
- Padgett, S.R., Nida, D.L., Biest, N.A., Bailey, M.R. & Zobel, J.F. (1993). Glyphosate tolerant soybeans in the U.S. in 1992: Field test, processing studies, and analytical evaluation. Monsanto Study 92-01-30-02, Technical Report MSL-12906, St. Louis, MO.
- Parker, S. L., Leznoff, A., Sussman, G. L., Tarlo, S. M. & Kronld, M. (1990). Characteristics of patients with food-related complaints. *Journal of Allergy and Clinical Immunology* **86**, 503-511.
- Pearson, W. & Lipman, D. (1988). Improved tools for biological sequence comparison. *Proc. Natl. Acad. Sci. USA* **85**, 2444-2448.
- Ream, J.E., Bailey, M.R., Leach, J.N. & Padgett, S.R. (1993). Assessment of the *in vitro* digestive fate of CP4 EPSP synthase. Monsanto Study 92-01-30-15, Technical Report MSL-12949, St. Louis, MO.
- Sampson, H. A. (1990). Immunologic mechanisms in adverse reactions to foods. *Immunology and Allergy Clinics of North America* **11**, 701-706.
- Sampson, H. A. & Burkes, A. W. (1996). Mechanisms of food allergy. *Annual Review of Nutrition* **16**, 161-177.
- Taylor, S.L. (1992). Chemistry and detection of food allergens. *Food Technol.* **39**, 146-152.
- Taylor, S.L., Lemanske Jr., R.F., Bush, R.K. & Busse, W.W. (1987). Food allergens: Structure and immunologic properties. *Ann. Allergy* **59**, 93-99.

## Compositional analyses of key components, evaluation of metabolites, food processing and nutritional modification

Nutrition data were obtained from analyses of glyphosate-tolerant and control soybeans (parental variety A5403) grown at nine field locations in 1992. These sites were chosen to be representative of the wide geographical area in which soybeans are grown. In addition, a four-site field test with limited analytical evaluations was performed in 1993. As the emphasis of these analyses was to examine any effects of the introduced gene and protein, the test material was derived from soybeans that had not been treated with glyphosate herbicide.

Although many of the analyses were performed on soybean seed, several soy protein products were also manufactured from GTS 40-3-2 for additional testing. Toasted meal was chosen because it is the main soybean protein product used in animal feed, defatted meal (flour) was prepared because it is the starting material for a large number of soybean products used in food, and protein concentrate from defatted meal was also evaluated because of its food use. In addition, crude lecithin and refined, bleached deodorized oil were manufactured.

## Proximate analysis

Compositional (proximate) analyses were performed on soybean seeds derived from GTS 40-3-2 and the parental non-transgenic control line, A5403. The concentrations of carbohydrate, protein, fat, moisture, fibre, and ash, expressed on a dry-weight basis, were measured according to published procedures of the Association of Official Analytical Chemists (AOAC).

## Methods

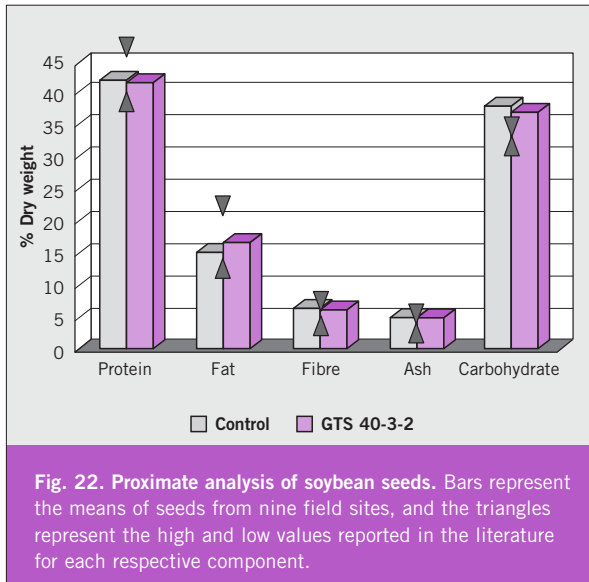
### Ash

Volatile organic matter was driven off when the sample was ignited at 550°C in an electric furnace. The residue was quantitated gravimetrically and calculated to determine percent ash (AOAC method 923.03, 1990). Using a 3 g sample, the lowest confidence level of this method was 0.2%.

### Carbohydrates

Carbohydrates were calculated by difference using the fresh weight-derived data and the following equation (USDA Agricultural Handbook No. 8, 1975):

$$\% \text{ carbohydrates} = 100\% - (\% \text{ protein} + \% \text{ fat} + \% \text{ ash} + \% \text{ moisture})$$



### Crude Fibre

Crude fibre is the loss on ignition of dried residue remaining after digestion of the samples with 1.25% sulfuric acid and 1.25% sodium hydroxide solutions under specific conditions (AOAC method 7.066-7.070, 1984). Using a 2 g sample, the lowest confidence level of this method was 0.2%.

### Fat

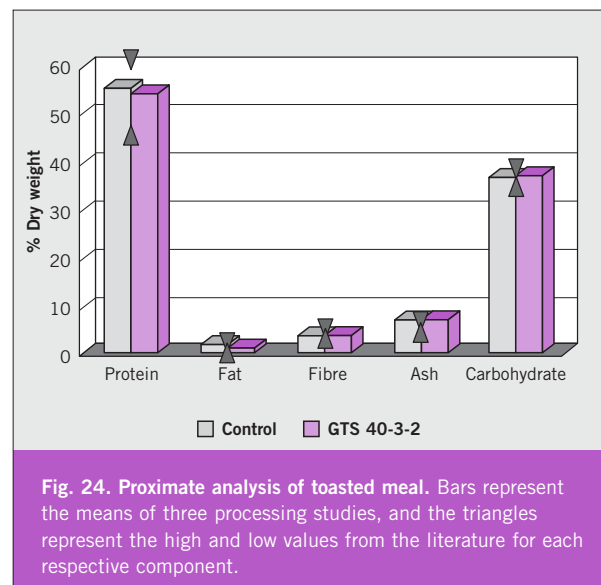
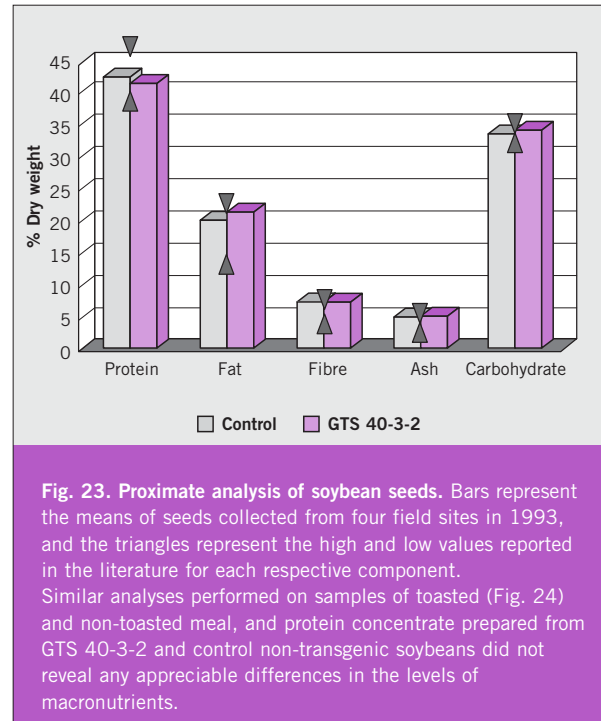
The fat was extracted using ether and hexane. The extract was washed with a dilute alkali solution and filtered through a sodium sulfate column. The remaining extract was evaporated, dried and weighed (AOAC methods 920.39C). Using a 2 g sample, the lowest confidence level of this method was 0.1% fat.

### Moisture

The sample was dried to a constant weight in a vacuum oven at 133°C (approximately 2 hours) (AOAC method 44-15A, 1987). The moisture loss was determined gravimetrically.

### Protein

Protein and other organic nitrogen in the sample were converted to ammonium sulfate by digesting the sample with sulfuric acid containing a potassium sulfate/titanium dioxide/cupric sulfate catalyst mixture. The acid digest was made alkaline, and the ammonia was distilled and titrated with standard acid. The percent nitrogen was determined and converted to protein using the factor 6.25 (AOAC method 988.05, 1990). Using a 1 g sample, the lowest confidence level of this method was 0.1% protein (0.02% nitrogen).



## Results

Compositional analyses of protein, fat, fibre, ash, and carbohydrate of GTS 40-3-2 and control soybean seeds obtained from nine field trial sites in 1992 and four trial sites in 1993 are presented in Figures 22 and 23, respectively. For each of the components measured, there were no statistically significant differences between GTS 40-3-2 and control soybeans, and with the exception of total carbohydrate, the measured values were within the range reported in the scientific literature. For the nine-

site study, the mean GTS 40-3-2 seed carbohydrate content was 37.1% dry weight, compared to a literature high of 34%. This difference was not judged as significant from a safety perspective as the mean carbohydrate concentration measured in control soybeans harvested from the same sites was 38.1% dry weight.

Similar analyses performed on samples of toasted (Fig. 24) and non-toasted meal, and protein concentrate prepared from GTS 40-3-2 and control non-transgenic soybeans did not reveal any appreciable differences in the levels of macronutrients.

## Amino acid composition

### Methods

Seed samples were subjected to acid hydrolysis using 6N HCl, then adjusted to pH 2.2 and the individual amino acids were quantitated using an automated

amino acid analyzer equipped with post-column ninhydrin derivatization and colorimetric detection (Moore & Stein 1954).

### Results

For the 18 amino acids measured, there were no statistically significant differences in the levels of any amino acid, including aromatic amino acids, between GTS 40-3-2 seeds and control non-transgenic soybean seeds.

The shikimate pathway plays a central role in plant metabolism and it has been estimated that about one-fifth of the carbon fixed by plants is subsequently channelled through this pathway (Haslam 1993). The lack of any difference in the levels of aromatic amino acids between transgenic GTS soybean seeds and non-transgenic seeds is supported by the fact that all available evidence suggests that EPSPS is not a rate-limiting step in the shikimate pathway, but that regulation of this pathway occurs at the first step in the conversion of erythrose 4-phosphate to 2-keto-3-deoxy-D-arabinoheptulosonate 7-phosphate (DAHP) by DAPH synthase (Weiss & Edwards 1980). Increased EPSPS activity would not, therefore, be expected to increase the levels of aromatic compounds in plants, and it has been observed that plant cells expressing 40-times more EPSPS than wild-type cultures do not overproduce aromatic amino acids (Smart *et al.* 1985).

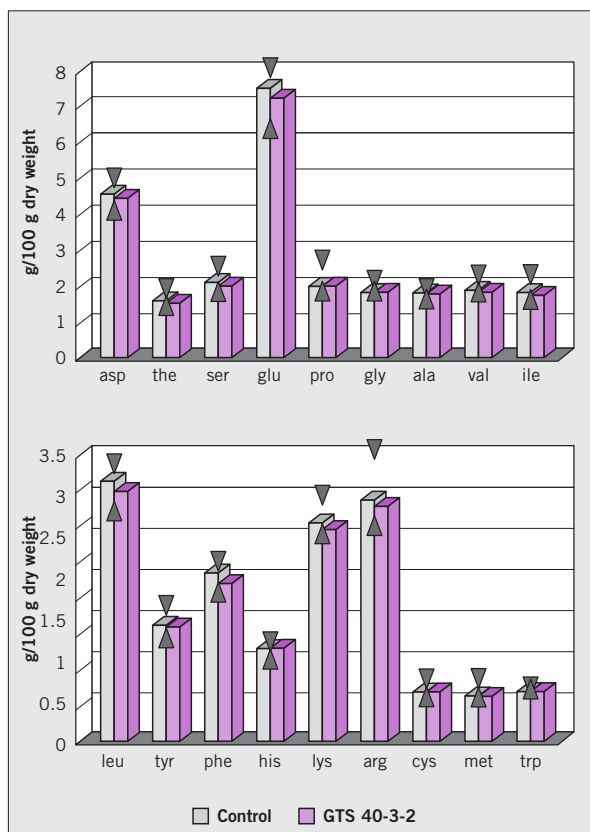
## Fatty acid composition

### Methods

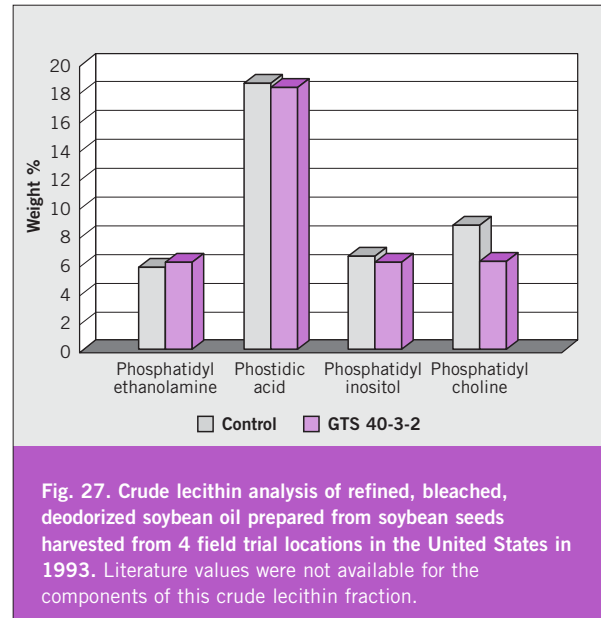
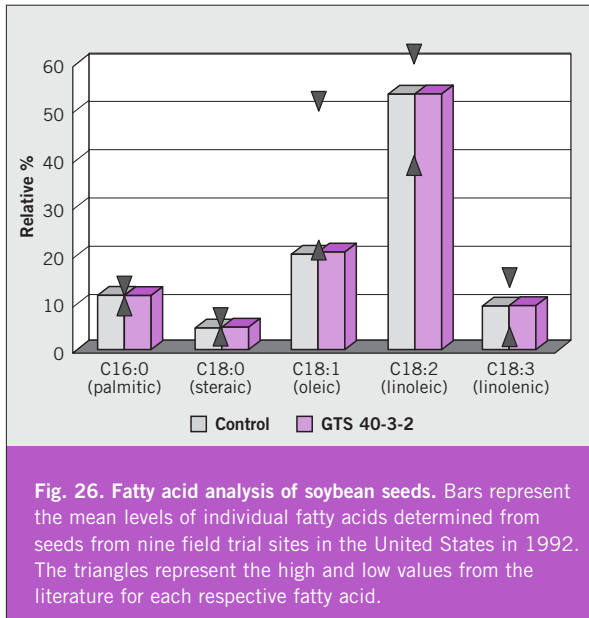
Samples of soybean seed or refined soybean oil were extracted with chloroform/methanol, saponified with alcoholic potassium hydroxide, and the free fatty acids were then extracted with hexane, washed with water and dried with sodium sulfate. Fatty acids were esterified with methanol, using boron trifluoride as a catalyst, taken up in heptane and subjected to gas chromatographic analysis (AOAC method 983.23 1990). The percent abundance of individual fatty acid methyl esters was calculated relative to the total amount of fatty acid methyl esters present. The lowest confidence level of this method was 0.1% of an individual fatty acid methyl ester.

### Results

The relative abundances of individual fatty acids were determined for samples of soybean seed and refined,



**Fig. 25. Amino acid analysis of soybean seeds.** Bars represent the mean concentrations of individual amino acids present in samples from soybean seeds harvested from nine field trials during 1992. The triangles represent the high and low values reported in the literature. Several literature values were calculated by converting g amino acid / 100 g protein to g amino acid / 100 g sample by using the mean protein concentration of the seeds analyzed, 41.5%.

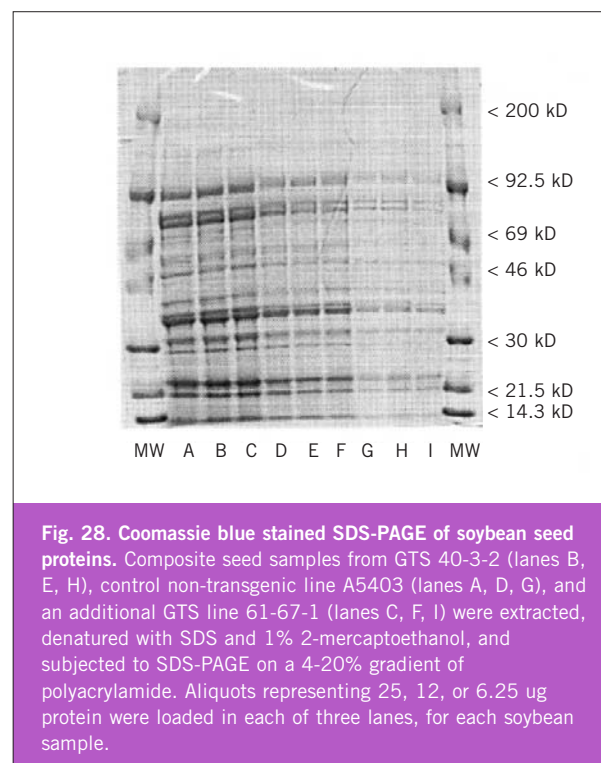


bleached, deodorized oil derived from GTS 40-3-2 and control non-transgenic soybeans (Fig. 26). There was only one statistically significant difference in the seed fatty acid composition between GTS 40-3-2 and control soybeans; this was for C22:0 fatty acids, which represent less than 0.6% of the total fatty acid fraction. All values, even those for C22:0 from seeds, were within the normal range of values for each respective fatty acid as reported in the literature.

Lecithin, which is a phosphatide removed from crude soybean oil, is used as a natural emulsifier, lubricant, and stabilizing agent (Waggle & Kolar, 1979). In addition to analysis of the free fatty acid profile of refined, bleached, deodorized soybean oil prepared from GTS 40-3-2 and non-transgenic soybeans, these oil samples were used to prepare crude lecithin fractions that were analyzed for phosphatide composition (phosphatidyl ethanolamine, phostidic acid, phosphatidyl inositol, phosphatidyl choline) (AOAC method Ja 7b-91). The relative abundance of each of these phosphatide components was comparable between crude lecithin fractions prepared from GTS 40-3-3 soybean oil and control non-transgenic soybean oil.

### Soybean seed proteins

The profiles of seed storage proteins extracted from GTS 40-3-2 and control non-transgenic soybean seeds were compared by sodium dodecylsulfate (SDS) polyacrylamide gel electrophoresis (PAGE). There were no discernable differences between transgenic and control soybeans (Fig. 28), which indicates that the gross



protein compositions of GTS 40-3-2 seeds are not materially different from that of the control soybeans.

### Levels of antinutrients

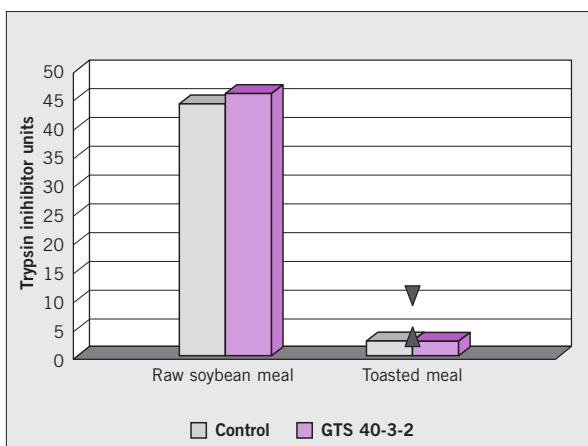
Soybean is naturally a source of several compounds that have been associated with antinutritive effects. These include protease inhibitors, such as soybean trypsin inhibitor, lectins (*e.g.*, soybean hemagglutinin),

isoflavones, and phytate, which complexes with inorganic phosphorous in seed but can also sequester other metallic ions such as iron, calcium, zinc, and magnesium, rendering these elements nutritionally unavailable. The levels of these antinutrient factors were determined in samples of GTS 40-3-2 soybean seed, as well as toasted soybean meal used for livestock feed, and compared with the levels found in the parental non-transgenic soybean line.

### Trypsin inhibitors

The antinutritive effect of trypsin inhibitors in unheated soybean products has been the subject of much research (Rackis *et al.*, 1986). The destruction of trypsin inhibitors and consequent elimination of hypertrophic pancreas effects is an important step in the processing of raw soybeans into products with excellent protein quality (Anderson *et al.* 1979).

Trypsin inhibitory activity was measured on alkaline (pH 9.5 - 9.8) extracts of raw soybean seed, or toasted meal, by incubation with a known concentration of trypsin, followed by the addition of benzoyl-D-arginine-p-nitroanilide (BAPNA). Measurements of the absorbance at 410 nm were taken after 10 minutes of reaction. Uninhibited trypsin catalyzes the hydrolysis of BAPNA, forming a yellow-coloured p-nitroaniline. One trypsin unit was defined as an increase equal to 0.01 absorbance units at 410 after 10 minutes per 10 ml reaction volume. The lowest confidence level of this method was 1 trypsin inhibitor unit (TIU) / mg sample, using a 1 g sample.



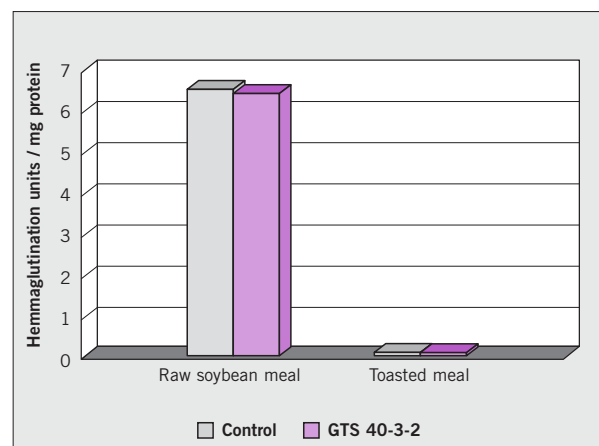
**Fig. 29.** Trypsin inhibitor activity of raw and toasted soybean meal. Bars represent the results of duplicate studies, and the triangles represent the high and low values for trypsin inhibitor activity reported in the literature for toasted soybean meal.

In comparing extracts of raw soybean seeds from GTS 40-3-2 and non-transgenic control lines (Fig. 29), there were no statistically significant differences in trypsin inhibitor activity. The normal processing of soybean meal to produce toasted meal results in a greater than 90% elimination of trypsin inhibitor activity from both GTS 40-3-2 and control material (Fig. 8.9).

### Lectin analysis

Plant lectins are a class of proteins with specific binding affinities for carbohydrate containing glycoproteins that are usually present in plant cell walls and the plasma membrane of cells. The binding of lectins to cell surface glycoproteins may cause agglutination, mitosis, or other biochemical changes in the cell. The ingestion of lectins, such as soybean hemagglutinin, has been associated with a range of antinutritive effects and some disease pathologies. Soybean lectin has been quoted as being responsible for about 25% of the growth inhibition attributable to the ingestion of raw soybean meal by rats (Leiner 1953), although it has since been concluded by some that soybean agglutinin does not play any major role as a determinant of the nutritional quality of soybean protein (Leiner 1980). Other authors still believe that circumstantial evidence exists that soybean lectin may make an appreciable contribution to observed growth inhibition caused by dietary exposure to uncooked soybean meal (Pusztai 1989).

The levels of soybean lectin in raw and toasted soybean meal were estimated by measuring the hemagglutination activity of various extracts against



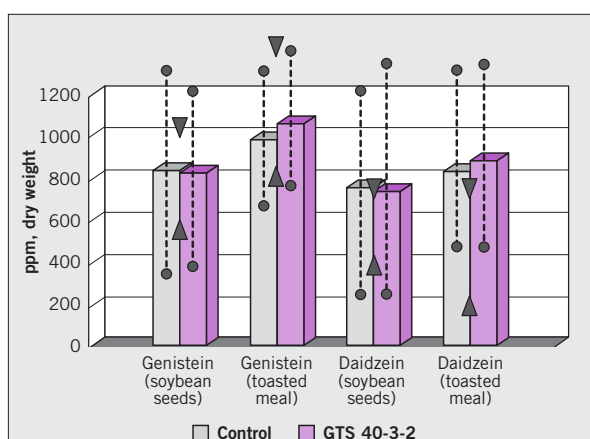
**Fig. 30.** Soybean lectin analysis of raw and toasted soybean meal. Bars represent the mean values obtained using composite samples of soybeans harvested from nine field trials during 1992. Values are expressed as hemagglutination units (HU) / mg protein.

rabbit red blood cells (Leiner, 1955; Klurfeld & Dritchewski, 1987). There were no statistically significant differences in the lectin activity between GTS 40-3-2 and control non-transgenic soybeans. The level of hemagglutination activity in raw soybean meal was less than 7 hemagglutination units (HU) / mg protein and essentially undetectable in samples of toasted meal (Fig. 30). A comparison of the hemagglutinin activity observed for raw meal in these tests with previously published values of 60-426 HU / mg protein was not informative due to the variability in red cell lots. The sensitivity of the assay was established in positive control tests with purified soybean lectin, in which values of 461-541 HU / mg protein were measured.

### Isoflavone analysis

The isoflavones genistein, daidzein, and coumestrol are naturally present in soybeans and their ingestion has been linked to a number of biochemical effects in mammalian species, including estrogenic and hypocholesterolemic activities (Wang *et al.* 1990; Murphy 1982). They have also been reported to contribute to deleterious effects on livestock animals fed soybean meal (Setchell *et al.* 1987).

The bound and free forms of daidzein and genistein were determined in samples of raw and toasted soybean meal by high pressure liquid chromatography (HPLC) separation (Pettersson & Kiessling, 1984). Sample extracts, and extracts following



**Fig. 31. Genistein and daidzein analysis of soybean seed and toasted meal.** For isoflavone levels in soybean seeds, the bars represent the means of values obtained from seed harvested from nine field trial sites in 1992, and in the case of toasted meal, the bars represent the means of three processing studies. The thin lines represent the ranges of experimentally determined values and the literature high and low values in each case are indicated by the triangles.

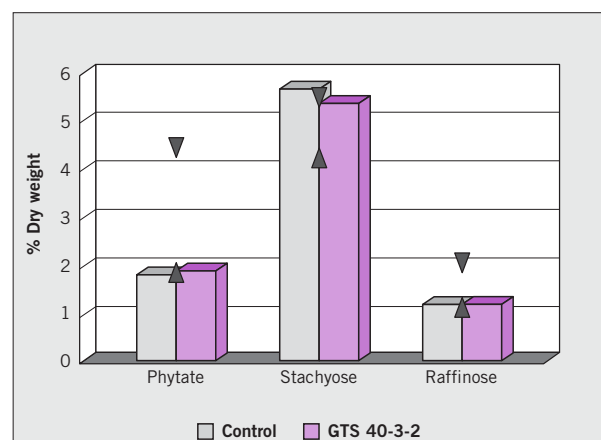
acid hydrolysis to liberate bound isoflavones, were analyzed to calculate the concentrations of free and total isoflavones, respectively. Concentrations of bound isoflavones were calculated as the difference of these two values.

No statistically significant differences in the levels of any isoflavones measured in either raw or toasted soybean meal were detected between GTS 40-3-2 and non-transgenic control soybeans (Fig. 31). The large variability observed in values determined for seeds harvested from different field trial sites was attributed to the effect of environmental variability on the formation of these compounds in plants.

### Stachyose, raffinose, and phytate analysis of soybean meal

The low molecular weight carbohydrates, stachyose and raffinose, are primarily responsible for flatus activity, which is a well known characteristic of soybean products (Rackis 1976). Phytic acid (phytate) is a hexaphosphoric acid derivative of inositol, and exists mainly in soybean seeds as an insoluble, non-nutritionally available calcium-magnesium-potassium complex (Mohamed *et al.* 1991). Phytate is not broken down in monogastric animals (*e.g.*, poultry, fish, swine) and is the main reason that livestock feeds for these animals must be supplemented with additional phosphorus and other minerals, or with phytase enzyme to degrade phytate.

The levels of stachyose and raffinose in extracts prepared from toasted soybean meal were determined by HPLC (Dunmire & Otto 1979). Phytic acid was



**Fig. 32. Phytate, stachyose, and raffinose analysis of toasted meal.** Bars represent the means of three processing studies, and the triangles represent the high and low values from the literature for each component.



extracted with dilute HCl and separated from inorganic phosphates by anion exchange chromatography (Ellis & Morris 1983). Bound phytate was eluted with NaCl solution and digested with a mixture of sulfuric and nitric acid to liberate free phosphate, which was quantitated spectrophotometrically following reaction with ammonium molybdate and sulfonic acid. Values were converted to phytic acid based on molecular weight equivalence and the lowest confidence level of the assay was 0.028% phytic acid based on a 2 g sample.

There were no statistically significant differences in the respective levels of stachyose, raffinose, or phytate measured in samples of toasted meal prepared from GTS 40-3-2 or non-transgenic control soybeans (Fig. 32).

### Nutrient bioavailability - confirmatory animal feeding studies

In order to establish that the genetic modification resulting in GTS 40-3-2 did not adversely affect the wholesomeness (ability to support typical growth and well-being) of soybean products, animal feeding studies were performed with laboratory rats, broiler chickens, catfish, and dairy cows. Both processed and unprocessed soybean meal was tested on rats because the majority of soybeans used for human food and animal feed are processed by heat treatment, and because rats serve as a surrogate for wild mammals that may eat soybeans in the field. Poultry consume about 49% of the soybeans fed to farm animals and were the subject of a six-week growth study, and dairy cows were included in a four week study since ruminants are normally fed raw soybeans as a source of protein. The catfish study was included since soybean meal is used in diets for commercial aquaculture. Lastly, unprocessed soybean meal was fed for 5 days to bobwhite quail, since birds may feed on soybeans left in the field after harvest.

## Methods

### *Rat Four-Week Feeding Study*

Eight week old male and female Charles River CD rats were fed rodent chow containing either processed or unprocessed soybean meal from GTS 40-3-2 or control non-transgenic soybeans for four weeks, ad libitum, at substitution levels of 24.8% or up to 10%, respectively. Feed consumption and body weight were measured at weekly intervals, and rats were observed twice daily for mortality and adverse clinical signs. At the end of the

study, all test animals were sacrificed and necropsied. Liver, testes, and kidneys were weighed and approximately 40 tissues were collected and saved from each animal. Dunnett's multiple range comparison test (two-tailed) was used to compare in-life body weights, cumulative body weight gain and food consumption for test and control groups. Terminal body weights, absolute organ weights, and organ/body weight ratios were evaluated by decision-tree statistical analysis procedures to detect group differences and analyze for trends.

### *Broiler Chicken Six-Week Study*

Commercial broiler chicks (White Plymouth Rock x White Cornish; Cobb 500 cockerel x Cobb 500 pullet) were fed test diets containing processed meal from GTS 40-3-2 or the control parental non-transgenic A5403 soybeans, supplemented with corn meal as the only other source of protein. Diets were formulated so as to ensure approximately equal amounts of essential amino acids (methionine, cysteine, lysine, arginine, tryptophan, and threonine), did not contain any medications or growth promoting feed additives, and met the National Research Council requirements for poultry feed. Birds were checked daily for mortality, and any that died on test were removed, weighed and necropsied to determine probable cause of death. Body weights and food consumption were measured, and at the termination of the study, birds were sacrificed and major and minor pectoralis muscles (breast muscles) from the right side were dissected and weighed. Abdominal fat pads were also removed and weighed.

### *Dairy Cow Four-Week Study*

Thirty-six multiparous Holstein dairy cows (93-196 days of lactation) were fed a mixed diet ration (35% alfalfa hay, 17% corn silage, 37% commercial grain mix) containing 10% (w/w dry matter basis) raw soybeans from GTS 40-3-2 or control non-transgenic A5403 soybean lines. This dietary level represented the upper limit for incorporation of raw soybeans into mixed cow diets as fed by dairy farmers, and cows were pre-adapted to high soybean diets prior to the start of the study. Milk samples collected daily during the course of the study were analyzed for lactose, fat, protein, and somatic cells. Total urine and fecal output was collected daily during the last week of the study to determine dry matter digestibility and nitrogen balance.

### *Catfish Ten-Week Study*

Fingerling channel catfish (*Ictalurus punctatus*), Mississippi Select strain, were maintained for 10 weeks

in glass aquaria and reared on a diet containing soybean meal from GTS 40-3-2 or control non-transgenic soybeans at the same substitution levels used commercially (45-47% w/w). All diets were prepared to contain a final protein concentration of 32%. Fish were weighed at the beginning of the study and on weeks 2, 6, and 10, at which times feed consumption was quantified by subtracting the weight of uneaten pellets

removed from the bottoms of tanks from the quantity of feed administered. The cumulative feed conversion ratio was estimated at weeks 2, 6, and 10 by dividing the sum of the feed offered to that point by corresponding total weight gain, adjusting for mortalities. At the end of the study, several fish were selected at random and the edible tissue composited and subjected to proximate analysis.

**Table 5. Comparison of feed efficiencies across feeding studies**

<i>Line</i>	<i>Mean Feed Consumption (g/animal)</i>	<i>Mean Feed Efficiency</i>	<i>Mean Weight Gain (g)</i>	<i>Mean Final Weight (g)</i>	
<b>Rat Feeding Study (4 weeks) Processed soybeans</b>					
<b>Males</b>					
Negative control	811	4.58	177 <sup>a</sup>	426 <sup>a</sup>	
A5403 control	764	4.63	165 <sup>a,b</sup>	415 <sup>a,b</sup>	
GTS 40-3-2	749	4.86	154 <sup>b</sup>	403 <sup>b</sup>	
<b>Females</b>					
Negative control	549	8.23	66.7	256	
A5403	538	7.87	68.4	259	
GTS 40-3-2	538	8.78	61.3	252	
<b>Rat Feeding Study (4 weeks) Unprocessed soybeans</b>					
<b>Males</b>					
Negative control	753	6.55	115	431	
A5403 5%	755	7.26	104	421	
A5403 10%	769	7.25	106	424	
GTS 40-3-2 5%	750	7.35	102	420	
GTS 40-3-2 10%	768	6.86	112	430	
<b>Females</b>					
Negative control	510	12.6	40.6	241	
A5403 5%	493	16.3	30.2	231	
A5403 10%	513	13.9	36.8	238	
GTS 40-3-2 5%	502	13.9	36.2	237	
GTS 40-3-2 10%	491	14.2	34.6	236	
<b>Broiler Chicken Study (6 weeks) Processed soybeans</b>					
<b>Combined Sex – No statistically significant differences were observed, <math>p &lt; 0.05</math></b>					
A5403 control	3893	1.816	2147	2193	
GTS 40-3-2	3844	1.832	2099	2144	
<b>Catfish Study (10 weeks) Processed soybeans</b>					
<b>Mixed Sex - No statistically significant differences were observed, <math>p &lt; 0.05</math></b>					
A5403 control	22.1	1.12	19.7	22.6	
GTS 40-3-2	21.8	1.17	18.8	21.8	
<i>a, b: Means with different letters are statistically different, <math>p &lt; 0.05</math></i>					
<i>Line</i>	<i>Milk (kg/day)</i>	<i>Fat (%)</i>	<i>3.5% Fat-corrected milk (FCM) (kg/day)</i>	<i>Net Energy Intake (mcal NEL/day)</i>	<i>FCM/NEL (kg/mcal)</i>
<b>Dairy Cow Study (4 weeks) Raw, cracked soybeans</b>					
A5403 control	34.9	3.37	34.1 <sup>a</sup>	40.1	0.81
GTS 40-3-2	36.2	3.59	36.8 <sup>b</sup>	42.9	0.88
<i>a, b: Means with different letters are statistically different, <math>p &lt; 0.05</math></i>					

## Results

The feed efficiencies (feed conversion ratios) of both GTS 40-3-2 and non-transgenic control soybeans, when used as components of animal feed, were summarized and compared across studies (Table 5). The bobwhite quail study was not included in this comparison because of its short duration (5 days). No statistically significant differences in feed efficiencies were observed when GTS 40-3-2 was used as a feed source compared to the parental variety, A5403. These results were consistent with the extensive compositional analyses demonstrating that GTS 40-3-2 was not significantly different from the control soybeans in terms of its nutritional properties.

## References

- Anderson, R.L., Rackis, J.J. & Tallent, W.H. (1979). Biologically active substances in soy products. In: Soy Protein and Human Nutrition. H.L. Wilke, D.T. Hopkins & D.H. Waggle, eds. Academic Press, New York. pp. 209-233.
- AOAC Method 44-15A. (1987). Moisture-air-oven methods. In AOAC Official Methods of Analysis, Association of Official Analytical Chemists, Arlington, Virginia.
- AOAC Method 7.066-7.070. (1984). Fiber (crude) in animal feed, ceramic fiber filter method. In AOAC Official Methods of Analysis, Association of Official Analytical Chemists, Arlington, Virginia.
- AOAC Method 920.39C. (1990). Fat (crude) of ether extract in animal feed. In AOAC Official Methods of Analysis, Association of Official Analytical Chemists, Arlington, Virginia.
- AOAC Method 923.03. (1990). In Official Methods of Analysis, 15th Edition. Association of Official Analytical Chemists, Arlington, Virginia, modified.
- AOAC Method 983.23. (1990). Fat in foods, chloroform-methanol extraction. In Official Methods of Analysis, 15th Edition. Association of Official Analytical Chemists, Arlington, Virginia.
- AOAC Method 988.05. (1990). Protein (crude) in animal feed, CuSO<sub>4</sub>/TiO<sub>2</sub> mixed catalyst Kjeldahl method. In AOAC Official Methods of Analysis, Association of Official Analytical Chemists, Arlington, Virginia.
- AOAC Method Ja 7b-91 (1993). In Official Methods and Recommended Practices of the Association of Official Analytical Chemists, 4th Edition, Arlington, Virginia.
- Dunmire, D. & Otto, S. (1979). HPLC determination of sugars in various food products. *Journal of the Official Association of Analytical Chemists* **62**, 176-185.
- Ellis, R. & Morris, E.R. (1983). Improved ion-exchange phytate method. *Cereal Chem.* **60**, 121-124.
- Haslam, E. (1993). Shikimic acid: Metabolism and metabolites. John Wiley & Sons, Chichester, England.
- Klurfeld, D.M. & Kritchevski, D. (1987). Isolation and quantitation of lectins from vegetable oils. *Lipids* **22**, 667-668.
- Leiner, I.E. (1953). Soyin, a toxic protein from the soybean. I. Inhibition of rat growth. *J. Nutr.* **49**, 527-540.
- Leiner, I.E. (1955). The photometric determination of the hemagglutinating activity of soyin and crude soybean extracts. *Arch. Biochem. Biophys.* **54**, 223-231.
- Leiner, I.E. (1980). Anti-nutritional factors as determinants of soybean quality. In: World Soybean Research Conference II: Proceedings. F. Corbin, ed. Westview Press, Boulder, CO. pp. 703-712.
- Mohamed, A.I., Mebrahtu, T. & Rangappa, M. (1991). Nutrient composition and anti-nutritional factors in selected vegetable soybean (*Glycine max L.*). *Plant Foods Hum. Nutr.* **41**, 89-100.
- Moore, S. & Stein, W.H. (1954). Procedures for the chromatographic determination of amino acids on four per cent cross-linked sulfonated polystyrene resins. *Journal of Biological Chemistry* **211**, 893-906.
- Murphy, P.A. (1982). Phytoestrogen content of processed soybean products. *Food Technology* **36**, 60-64.
- Pettersson, H. & Kiessling, K.H. (1984). Liquid chromatographic determination of the plant estrogens coumestrol and isoflavones in animal feed. *Journal of the Official Association of Analytical Chemists* **67**, 503-506.
- Pusztai, A. (1989). Lectins. In: Toxicants of Plant Origin: Volume II, Proteins and Amino Acids. P.R. Cheeke, ed. CRC Press, Boca Raton, FL. pp. 29-71.
- Rackis, J.J. (1976). Flatulence problems associated with soy products. In: World Soybean Research. L.D. Hill, ed. The Interstate Printers and Publishers, Inc., Danville, IL. pp. 892-903.
- Rackis, J.J., Wolf, W.J. & Baker, E.C. (1986). Protease inhibitors in plant foods: Content and inactivation. In: Nutritional and Toxicological Significance of

- Enzyme Inhibitors in Food. M. Friedman, ed. Plenum Press, New York. pp. 299-347.
- Setchell, K.D.R., Gosselin, S.J., Welsh, M.B., Johnston, J.O., Balistreri, W.F., Kramer, L.W., Dresser, B.L. & Tarr, M.J. (1987). Dietary estrogens - a probable cause of infertility and liver disease in captive cheetahs. *Gastroenterology* **93**, 225-233.
- Smart, C.C., Johanning, D., Muller, G. & Amrhein, N. (1985). Selective overproduction of 5-enol-pyruvylshikimate acid 3-phosphate synthase in a plant cell culture which tolerates high doses of the herbicide glyphosate. *Journal of Biological Chemistry* **260**, 16338-16346.
- USDA Agriculture Handbook No. 8. (1975). Composition of Foods. In Agricultural Handbook No. 8. United States Department of Agriculture, Washington, D.C. pp. 159-165.
- Waggle, D.H. & Kolar, C.W. (1979). Types of soy protein products. In: Soy Protein and Human Nutrition. H.L. Wilke, D.T. Hopkins, and D.H. Waggle, eds. Academic Press, New York. pp. 19-51.
- Wang, G., Kuan, S.S., Francis, O.J., Ware, G.M. & Carman, A.S. (1990). A simplified HPLC method for the determination of phytoestrogens in soybean and its processed products. *J. Agric. Food. Chem.* **38**, 185-190.
- Weiss, U. & Edwards, J.M. (1980). Regulation of the shikimate pathway. *In: The Biosynthesis of Aromatic Compounds*. John Wiley & Sons, New York, pp. 287-301 ●





# Évaluation de la sécurité sanitaire des aliments génétiquement modifiés *outils à l'intention* des formateurs

La FAO reconnaît que les biotechnologies constituent un outil important pour le développement durable de l'agriculture, des pêches et des forêts, ainsi que du secteur agro-alimentaire. À condition d'être judicieusement associées à d'autres technologies de production de denrées alimentaires ou de produits et de services agricoles, les biotechnologies peuvent contribuer dans une large mesure à la satisfaction des besoins d'une population en expansion et toujours plus urbanisée.

Ce programme de formation, *Évaluation de la sécurité sanitaire des aliments génétiquement modifiés: Outil à l'intention des formateurs* est constitué de trois parties et accompagné d'un CD-ROM contenant les supports visuels et les autres matériels de référence pertinents. La première partie, *Principes de l'évaluation de la sécurité sanitaire des aliments dérivés de plantes à ADN recombiné*, donne des orientations pour la mise en œuvre d'un cadre efficace pour l'évaluation de la sécurité sanitaire des aliments dérivés de plantes à ADN recombiné. La deuxième partie, *Outils et techniques à l'intention des formateurs* est un guide pratique pour la préparation et la tenue d'un atelier sur le même thème. Elle contient plusieurs listes récapitulatives et fiches, un modèle d'ordre du jour et un modèle de fiche d'évaluation d'un atelier, ainsi que cinq modules de présentation utiles pour les formateurs. Toutes les fiches, présentations et copies des documents pertinents du Codex alimentarius sont incluses dans le CD-ROM d'accompagnement. La troisième partie, consacrée aux *Études de cas*, présente trois dossiers d'évaluation de la sécurité sanitaire qui ont été condensés pour les besoins de la formation.

À l'achèvement de la formation dispensée à l'aide de ce guide, ceux qui l'auront suivie seront capables de planifier et de dispenser une formation à l'évaluation de la sécurité sanitaire des AGM que les autorités compétentes, les responsables de la réglementation et/ou les scientifiques spécialisés dans ce domaine pourront intégrer dans leurs propres programmes de formation.

ISBN 978-92-5-105978-4



9 789251 059784

TC/M/10110E/1/04.08/2000

